

LM117HVQML-SP RHA 4.25-V to 60-V 3-Terminal Adjustable Regulator

1 Features

- Radiation hardness assured (RHA) up to a total ionizing dose (TID) of 100 krad(Si)
 - High dose rate (HDR) option at 50–300 rad(Si)/s
 - Low dose rate (LDR) option at 10 mrad(Si)/s
- Specified 0.5-A output current
- Adjustable output down to 1.2 V
- Current limit constant with temperature
- Output is short-circuit protected

2 Applications

- [Satellite electrical power system \(EPS\)](#)

3 Description

The LM117HVQML-SP adjustable 3-terminal positive voltage linear regulator is capable of supplying 0.5 A over a 1.2-V to 57-V output range. It is simple to use and requires only two external resistors to set the output voltage.

The regulator is "floating" and sees only the input-to-output differential voltage, thus enabling supplies of several hundred volts to be regulated as long as the maximum input-to-output differential is not exceeded.

The flight-proven LM117HVQML-SP offers full overload protection such as current limit, thermal overload protection, and safe area protection. It is exceptionally versatile and can also be used as an adjustable switching regulator, a programmable output regulator, a precision current regulator, and more.

For lower voltage applications, the [LM117QML-SP](#) is a pin-to-pin drop-in replacement suitable for up to 41.25 V. For the negative complement, see the [LM137QML-SP](#) data sheet.

Device Information

PART NUMBER ⁽¹⁾	GRADE ⁽²⁾	PACKAGE ⁽³⁾
LM117HVGWRLQMLV	Flight grade QMLV, RHA 100 krad(Si) at LDR (10 mrad/s)	CFP SOIC (NAC) 16 pin 6.35 mm × 9.91 mm Mass = 0.467 g ⁽⁵⁾
5962R0722962VZA		
LM117HVGWRQMLV	Flight grade QMLV, RHA 100 krad(Si) at HDR (50–300 rad/s)	
5962R0722902VZA		
LM117HVNAC/EM	Engineering samples ⁽⁴⁾	
LM117HVHRLQMLV	Flight grade QMLV, RHA 100 krad(Si) at LDR (10 mrad/s)	TO-39 (NDT) 3 pin 8.26 mm × 8.26 mm Mass = 1.036 g ⁽⁵⁾
5962R0722961VXA		
LM117HVHRQMLV	Flight grade QMLV, RHA 100 krad(Si) at HDR (50–300 rad/s)	
5962R0722901VXA		
LM117HVH MDE	Flight grade QMLV, RHA 100 krad(Si) at LDR (10 mrad/s)	Die 2.18 mm × 2.36 mm
5962R0722961V9A		
LM117HVH MDR	Flight grade QMLV, RHA 100 krad(Si) at HDR (50–300 rad/s)	
5962R0722901V9A		

- (1) For all available packages, see the orderable addendum at the end of the data sheet.
- (2) For additional information about part grade, view [SLYB235](#).
- (3) The [TI Packaging](#) page can be referenced for additional packing details.
- (4) These units are intended for engineering evaluation only and are processed to a noncompliant flow. Not suitable for qualification, production, radiation testing, or flight use. Not warranted for performance over full MIL specified temperature range (–55°C to 125°C) or operating life.
- (5) Mass is accurate to ±10%.

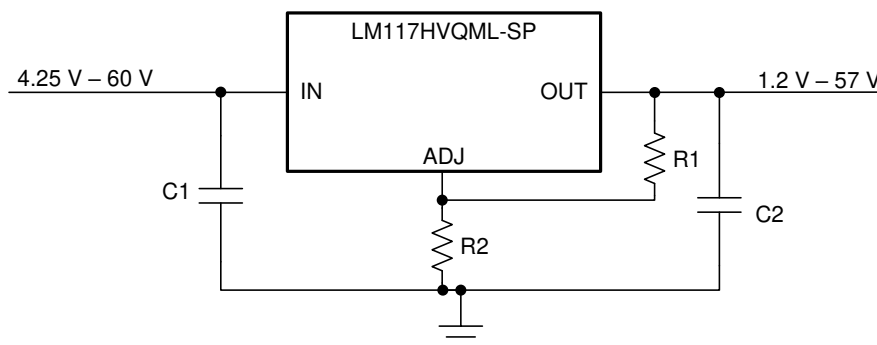

Simplified Schematic



Table of Contents

1 Features	1	8.2 Functional Block Diagram.....	12
2 Applications	1	8.3 Feature Description.....	14
3 Description	1	9 Application and Implementation	16
4 Revision History	2	9.1 Typical Applications.....	16
5 Related Products	3	10 Power Supply Recommendations	25
6 Pin Configurations and Functions	4	11 Layout	26
7 Specifications	5	11.1 Layout Guidelines.....	26
7.1 Absolute Maximum Ratings.....	5	12 Device and Documentation Support	27
7.2 ESD Ratings.....	5	12.1 Device Support.....	27
7.3 Recommended Operating Conditions.....	5	12.2 Documentation Support.....	27
7.4 Thermal Information.....	5	12.3 Receiving Notification of Documentation Updates..	27
7.5 Electrical Characteristics.....	6	12.4 Support Resources.....	27
7.6 Parameter Drift.....	7	12.5 Trademarks.....	27
7.7 Quality Conformance Inspection.....	8	12.6 Electrostatic Discharge Caution.....	27
7.8 Typical Characteristics.....	9	12.7 Glossary.....	27
8 Detailed Description	12	13 Mechanical, Packaging, and Orderable Information	28
8.1 Overview.....	12		

4 Revision History

NOTE: Page numbers for previous revisions may differ from page numbers in the current version.

DATE	REVISION	NOTES
October 2021	*	Initial release. Device split from shared data sheet (SNVS357).

5 Related Products

PART NUMBER	INPUT VOLTAGE RANGE	I _{out}	PART NUMBER SUFFIX	PACKAGE	RADIATION TESTING ⁽¹⁾	
LM117QML-SP	4.25 V to 41.25 V	1.5 A	K	TO-3 (K) 2 pin	HDR 100 krad(Si)	
					LDR 100 krad(Si)	
		0.5 A	H	TO-39 (NDT) 3 pin	HDR 100 krad(Si)	
					LDR 100 krad(Si)	
				Die	HDR 100 krad(Si)	
					LDR 100 krad(Si)	
GW	CFP SOIC (NAC) 16 pin	HDR 100 krad(Si)				
		LDR 100 krad(Si)				
LM117HVQML-SP	4.25 V to 60 V	0.5 A	H	TO-39 (NDT) 3 pin	LDR 100 krad(Si)	
					HDR 100 krad(Si)	
				Die	LDR 100 krad(Si)	
					HDR 100 krad(Si)	
				GW	CFP SOIC (NAC) 16 pin	LDR 100 krad(Si)
						HDR 100 krad(Si)
LM137QML-SP	-41.25 V to -4.25 V	1.5 A	H	TO-39 (NDT) 3 pin	HDR 30 krad(Si)	

(1) The [Device Information](#) table can be referenced for information on which part numbers correspond to LDR or HDR options.

6 Pin Configurations and Functions

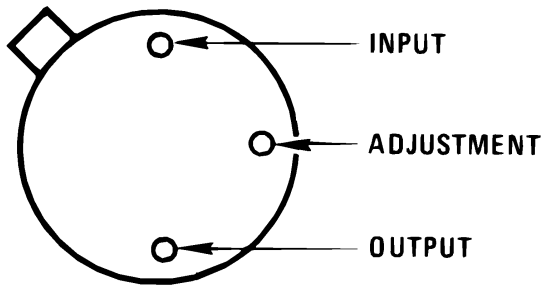

LM117H, LM117NDTTO-39 (NDT) 3-Pin Metal Can Package (Bottom View)

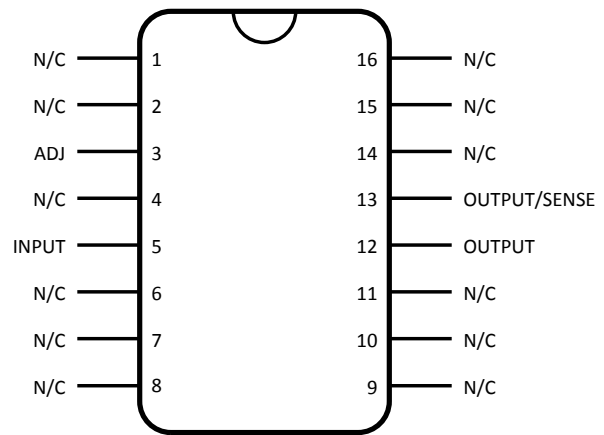

LM117GW CFP SOIC (NAC) 16-Pin Ceramic Package (Top View)

Table 6-1. Pin Functions

NAME	PIN		I/O ⁽¹⁾	DESCRIPTION
	TO-39 (NDT)	CFP SOIC (NAC)		
ADJ	2	3	–	Adjust pin.
V _{IN}	1	5	I	Input voltage pin for the regulator.
V _{OUT}	3, CASE	12	O	Output voltage pin for the regulator.
OUTPUT/SENSE	–	13	–	Used to sense the output voltage. Must be connected to V _{OUT} for proper operation.
N/C	–	1, 2, 4, 6, 7, 8, 9, 10, 11, 14, 15, 16	–	No connection. These pins have no internal connections and may be grounded or left floating. They may also be connected to the board heatsink and used for thermal dissipation.

(1) I = input, O = output, P = power, FB = feedback, GND = ground, NC = no connect

7 Specifications

7.1 Absolute Maximum Ratings

Over operating free-air temperature range (unless otherwise noted)⁽¹⁾

		MIN	MAX	UNIT
	Power dissipation ⁽²⁾	Internally Limited		
	Input-output voltage differential	-0.3	60	V
T _{stg}	Storage temperature	-65	150	°C
T _{Jmax}	Maximum junction temperature		150	°C
	Lead temperature metal package		300	°C

- Operation outside the *Absolute Maximum Ratings* may cause permanent device damage. *Absolute Maximum Ratings* do not imply functional operation of the device at these or any other conditions beyond those listed under *Recommended Operating Conditions*. If used outside the *Recommended Operating Conditions* but within the *Absolute Maximum Ratings*, the device may not be fully functional, and this may affect device reliability, functionality, performance, and shorten the device lifetime.
- The maximum power dissipation must be derated at elevated temperatures and is dictated by T_{Jmax} (maximum junction temperature), θ_{JA} (package junction to ambient thermal resistance), and T_A (ambient temperature). The maximum allowable power dissipation at any temperature is P_{Dmax} = (T_{Jmax} - T_A) / θ_{JA} or the number given in the *Absolute Maximum Ratings*, whichever is lower. Although power dissipation is internally limited, these specifications are applicable for power dissipations of 2 W for the TO-39 and CFP packages, and 20 W for the TO-3 package.

7.2 ESD Ratings

			VALUE	UNIT
V _(ESD)	Electrostatic discharge	Human-body model (HBM), per ANSI/ESDA/JEDEC JS-001 ⁽¹⁾ ⁽²⁾	±2000	V

- JEDEC document JEP155 states that 500-V HBM allows safe manufacturing with a standard ESD control process.
- Human-body model, 100 pF discharged through a 1.5-kΩ resistor.

7.3 Recommended Operating Conditions

Over operating free-air temperature range (unless otherwise noted)

		MIN	MAX	UNIT
T _A	Operating temperature	-55	125	°C
V _{IN}	Input voltage	4.25	60	V

7.4 Thermal Information

THERMAL METRIC ⁽¹⁾			LM117HVQML-SP		UNIT
			TO-39 (NDT)	CFP (NAC)	
			3 PINS (LM117H)	16 PINS (LM117GW)	
R _{θJA}	Junction-to-ambient thermal resistance	Still air	186	130	°C/W
		500 LF/min air flow	64	80	
R _{θJC(bot)}	Junction-to-case (bottom) thermal resistance		21	7	°C/W

- For more information, see the [Semiconductor and IC package thermal metrics](#) application report.

7.5 Electrical Characteristics

The following conditions apply, unless otherwise specified. $V_{Diff} = (V_I - V_O)$, $I_L = 8 \text{ mA}$, $V_O = 1.25 \text{ V}$ (nominal), over operating temperature range ($T = -55^\circ\text{C}$ to 125°C).

PARAMETER		TEST CONDITIONS (1)		SUBGROUP (2)	MIN	MAX	UNIT
V_{Ref}	Reference voltage	$V_{Diff} = 3 \text{ V}$	25°C , Post-radiation	1	1.2	1.3	V
				1		1.45	
		$V_{Diff} = 40 \text{ V}$		2, 3	1.2	1.3	
			25°C , Post-radiation	1		1.45	
V_{RLine}	Line regulation	$3 \text{ V} \leq V_{Diff} \leq 40 \text{ V}$, $V_O = V_{Ref}$	25°C	1	-8.64	8.64	mV
			25°C , Post-radiation	1	-40	40	
		125°C , -55°C	2, 3	-18	18		
V_{RLoad}	Load regulation	$V_{Diff} = 3 \text{ V}$, $10 \text{ mA} \leq I_L \leq 500 \text{ mA}$	25°C	1	-15	15	mV
			25°C , Post-radiation	1	-27	27	
		$V_{Diff} = 3.3 \text{ V}$, $10 \text{ mA} \leq I_L \leq 500 \text{ mA}$	125°C , -55°C	2, 3	-15	15	
		$V_{Diff} = 40 \text{ V}$, $10 \text{ mA} \leq I_L \leq 150 \text{ mA}$	25°C	1	-15	15	
V_{RTh}	Thermal regulation	$V_{Diff} = 40 \text{ V}$, $I_L = 150 \text{ mA}$, $t = 20 \text{ ms}$	25°C	1		6	mV
I_{Adj}	Adjust pin current	$V_{Diff} = 3 \text{ V}$	25°C	1		100	μA
			125°C , -55°C	2, 3		100	
				1, 2, 3		100	
$\Delta I_{Adj}/\text{Line}$	Adjust pin current change	$3 \text{ V} \leq V_{Diff} \leq 40 \text{ V}$	25°C	1	-5	5	μA
			125°C , -55°C	2, 3	-5	5	
$\Delta I_{Adj}/\text{Load}$	Adjust pin current change	$V_{Diff} = 3 \text{ V}$, $10 \text{ mA} \leq I_L \leq 500 \text{ mA}$	25°C	1	-5	5	μA
			125°C , -55°C	2, 3	-5	5	
		$V_{Diff} = 40 \text{ V}$, $10 \text{ mA} \leq I_L \leq 150 \text{ mA}$	25°C	1	-5	5	
		$V_{Diff} = 40 \text{ V}$, $10 \text{ mA} \leq I_L \leq 100 \text{ mA}$	125°C , -55°C	2, 3	-5	5	
I_Q	Minimum load current	$V_{Diff} = 3 \text{ V}$, $V_O = 1.7 \text{ V}$	25°C	1		5	mA
			125°C , -55°C	2, 3		5	
		$V_{Diff} = 40 \text{ V}$, $V_O = 1.7 \text{ V}$		1, 2, 3		5	
			25°C	1		8.2	

PARAMETER		TEST CONDITIONS ⁽¹⁾		SUBGROUP ⁽²⁾	MIN	MAX	UNIT
I _{OS}	Output short circuit current	V _I = 4.25 V	25°C	1	0.5	1.8	A
		V _I = 60 V	25°C	1	0	0.4	
ΔV _I / ΔV _O	Ripple rejection	V _I = 6.25 V, I _L = 125 mA, e _r = 1 V _{RMS} , f = 120 Hz	25°C	4	66		dB
			25°C Post-radiation	4	55		

- (1) Pre- and post-irradiation limits are identical for the parameters above unless specified by the test conditions.
(2) For subgroup definitions, see [Quality Conformance Inspection](#) table.

7.6 Parameter Drift

The following deltas are for Group C (Life Test). Data is measured at 25°C.

PARAMETER		TEST CONDITIONS	SUBGROUP ⁽¹⁾	MIN	MAX	UNIT
V _{Ref}	Reference voltage	V _{Diff} = 3 V	1	-0.01	0.01	V
		V _{Diff} = 40 V	1	-0.01	0.01	V
V _{RLine}	Line regulation	3 V ≤ V _{Diff} ≤ 40 V, V _O = V _{Ref}	1	-4	4	mV
		40 V ≤ V _{Diff} ≤ 60 V, I _L = 60 mA	1	-6	6	
I _{Adj}	Adjust pin current	V _{Diff} = 3 V	1	-10	10	μA
		V _{Diff} = 40 V	1	-10	10	μA

- (1) For subgroup definitions, see [Qualirt Conformance Inspection](#) table.

7.7 Quality Conformance Inspection

MIL-STD-883, Method 5005 - Group A

SUBGROUP	DESCRIPTION	TEMP (°C)
1	Static tests at	25
2	Static tests at	125
3	Static tests at	-55
4	Dynamic tests at	25
5	Dynamic tests at	125
6	Dynamic tests at	-55
7	Functional tests at	25
8A	Functional tests at	125
8B	Functional tests at	-55
9	Switching tests at	25
10	Switching tests at	125
11	Switching tests at	-55

7.8 Typical Characteristics

Output capacitor = 0 μ F unless otherwise noted

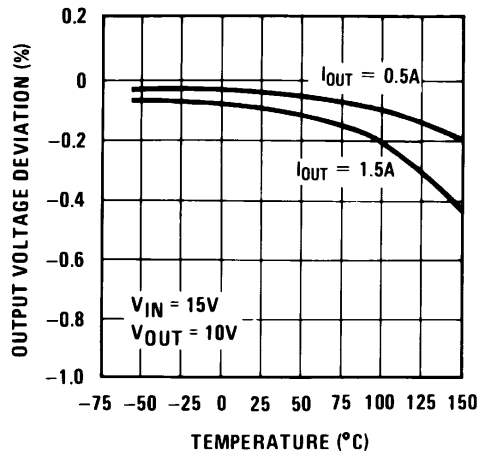

Figure 7-1. Load Regulation

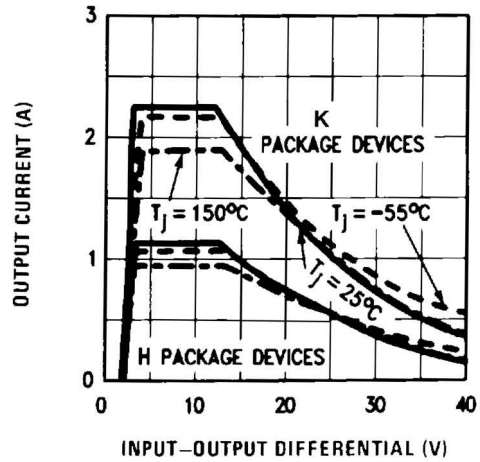

Figure 7-2. Current Limit

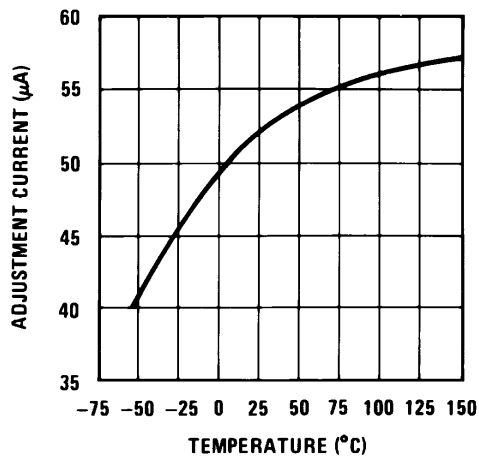

Figure 7-3. Adjustment Current

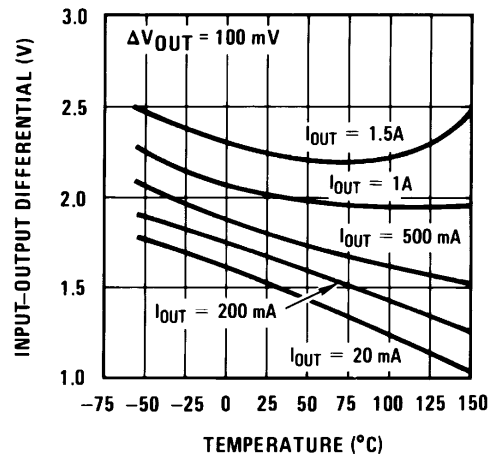

Figure 7-4. Dropout Voltage

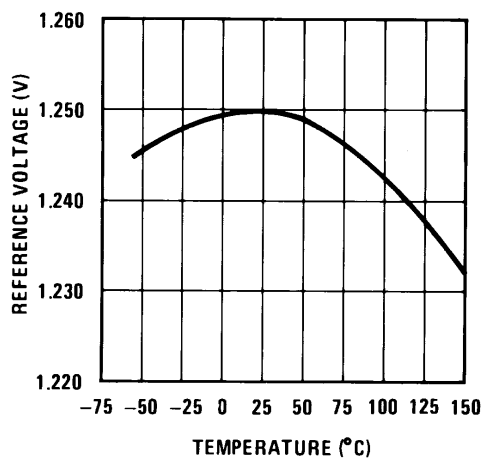

Figure 7-5. Temperature Stability

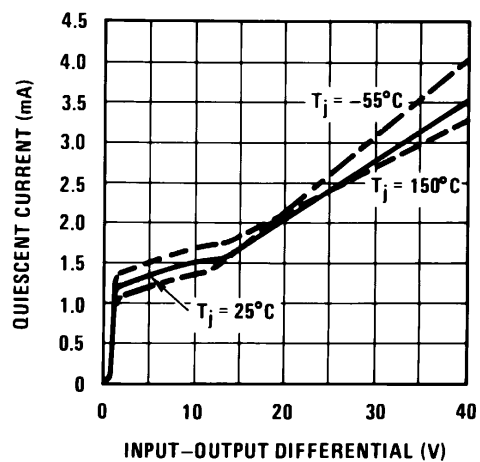

Figure 7-6. Minimum Operating Current

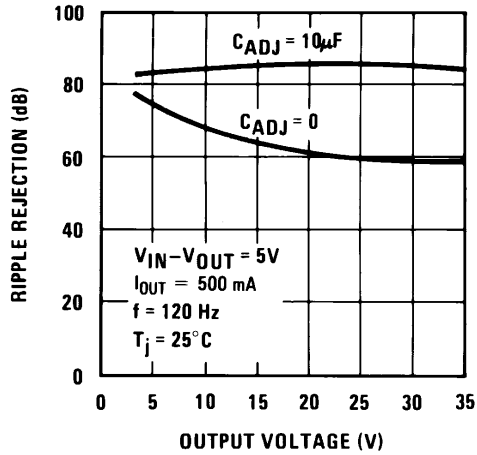

Figure 7-7. Ripple Rejection

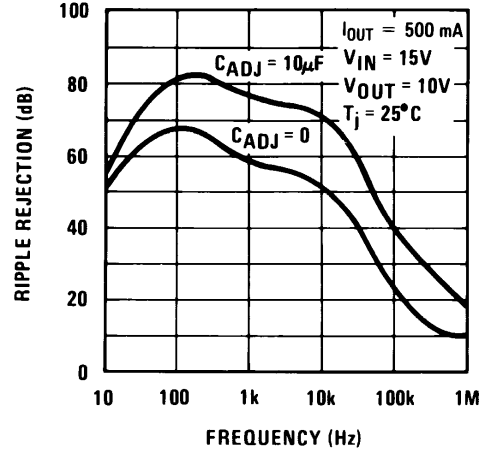

Figure 7-8. Ripple Rejection

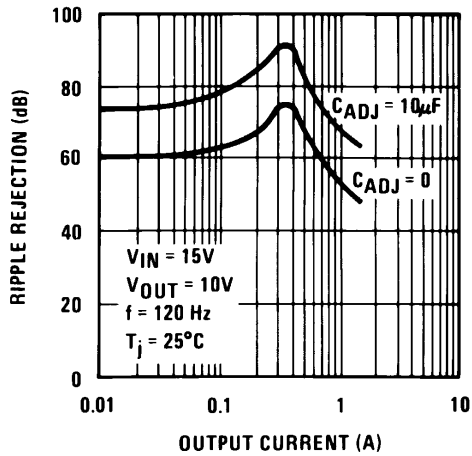

Figure 7-9. Ripple Rejection

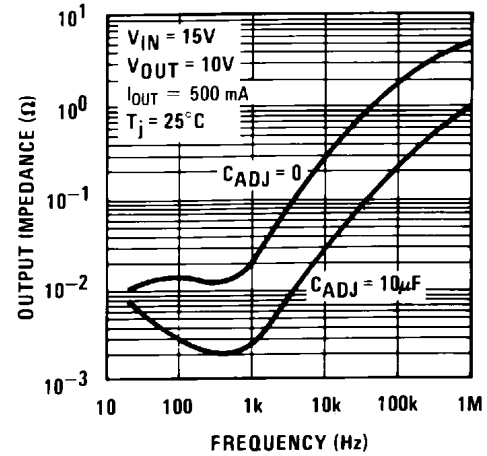

Figure 7-10. Output Impedance

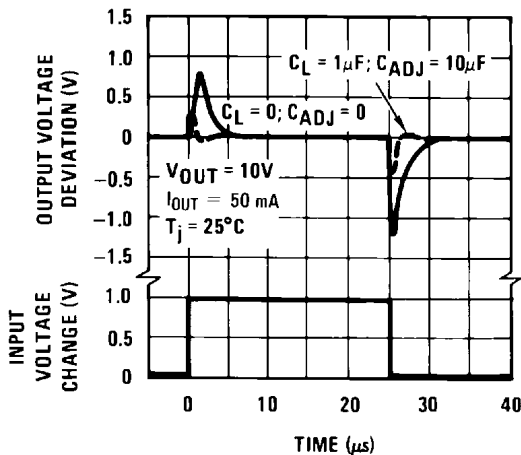

Figure 7-11. Line Transient Response

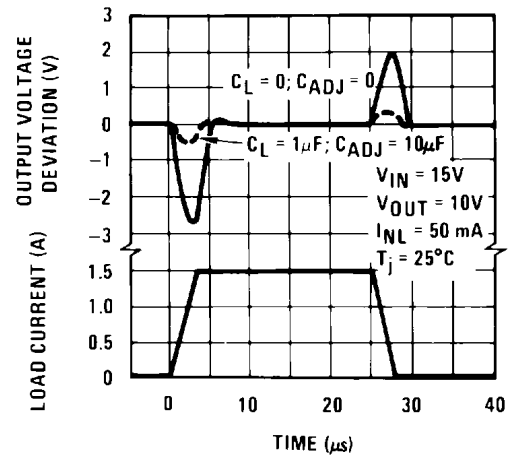

Figure 7-12. Load Transient Response

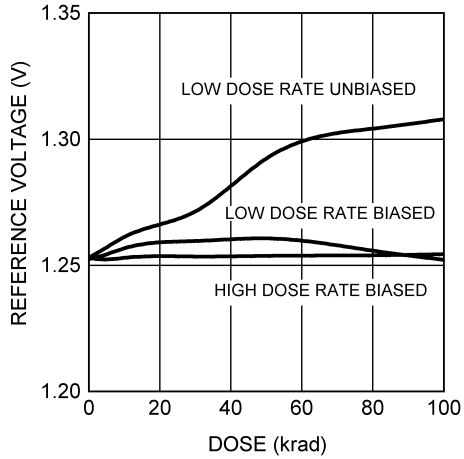

Figure 7-13. Reference Voltage

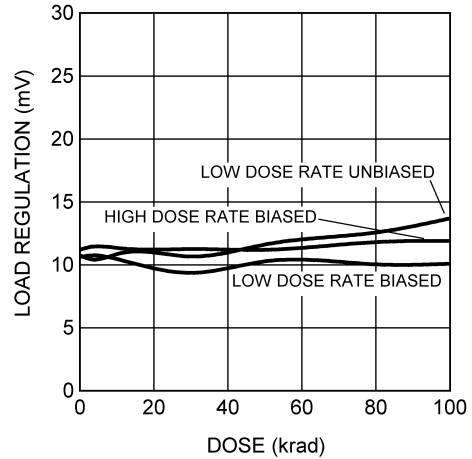

Figure 7-14. Load Regulation

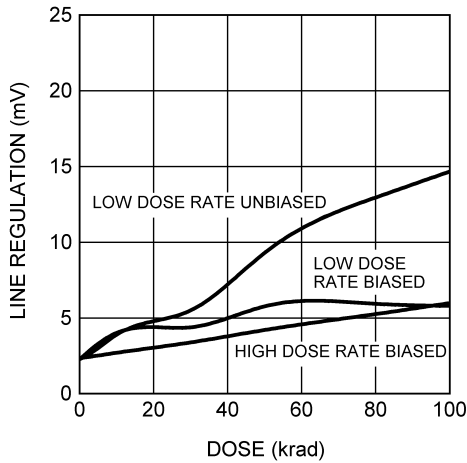

Figure 7-15. Line Regulation

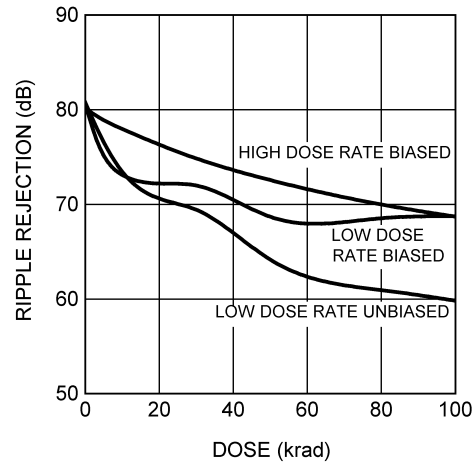

Figure 7-16. Ripple Rejection

8 Detailed Description

8.1 Overview

The LM117HVQML-SP 3-terminal positive voltage linear regulator is capable of supplying 0.5 A over a 1.2-V to 57-V output range. It is simple to use and requires only two external resistors to set the output voltage. Further, both line and load regulation are better than standard fixed regulators.

The regulator is "floating" and sees only the input-to-output differential voltage, thus enabling supplies of several hundred volts to be regulated as long as the maximum input-to-output differential is not exceeded (i.e. don't short circuit the output).

The LM117HVQML-SP offers full overload protection such as current limit, thermal overload protection, and safe area protection. All overload protection circuitry remains fully functional even if the adjustment terminal is disconnected.

Typically, no capacitors are needed unless the device is situated more than 6 in from the input filter capacitors in which case an input bypass is needed. An optional output capacitor can be added to improve transient response. The adjustment terminal can be bypassed to achieve very high ripple rejection ratios which are difficult to achieve with standard 3-terminal regulators.

This device makes an especially simple adjustable switching regulator, a programmable output regulator, or by connecting a fixed resistor between the adjustment pin and output it can be used as a precision current regulator. Supplies with electronic shutdown can be achieved by clamping the adjustment terminal to ground which programs the output to 1.2 V where most loads draw little current.

8.2 Functional Block Diagram

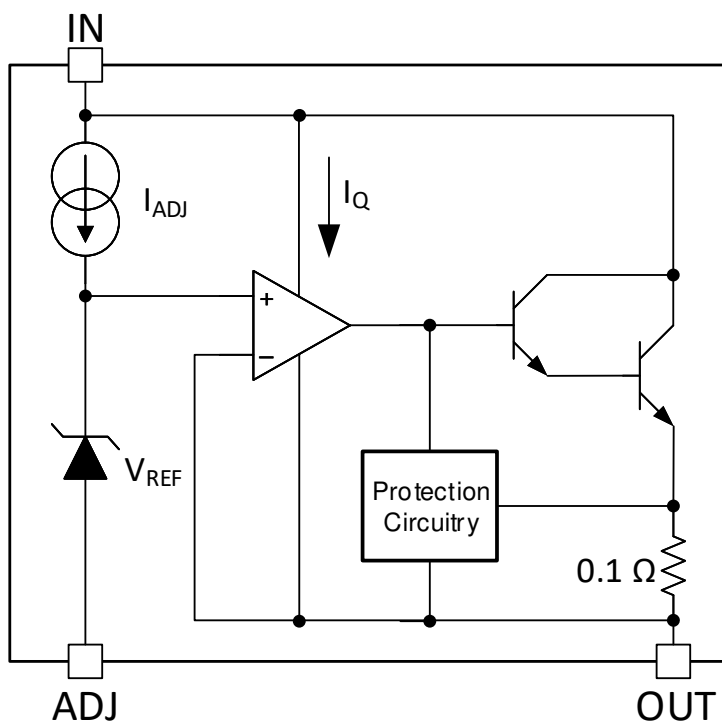

8.2.1 Simplified Device Schematic

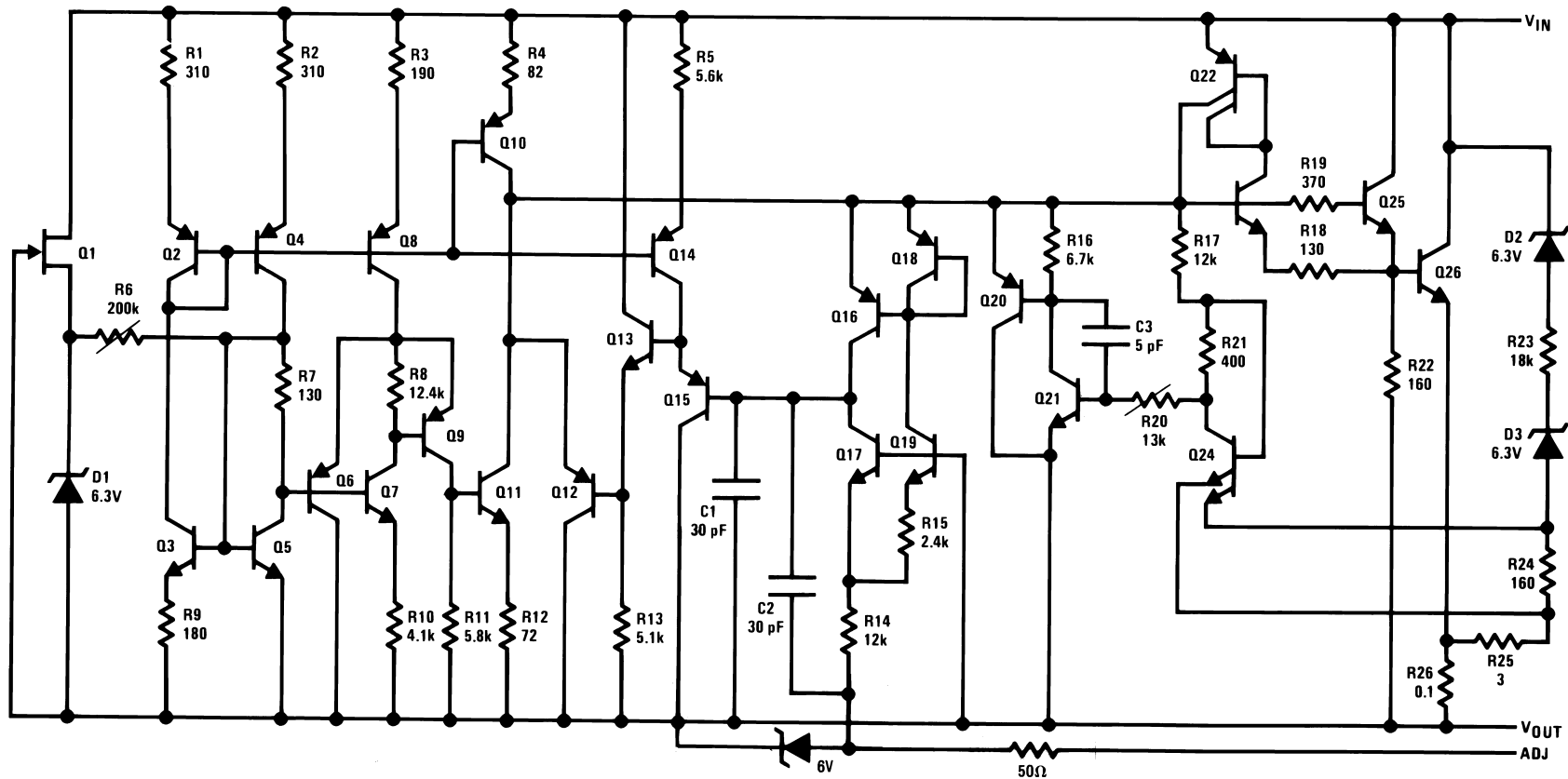

8.3 Feature Description

8.3.1 Setting Output Voltage

In operation, the LM117HVQML-SP develops a nominal 1.25-V reference voltage, V_{REF} , between the output and adjustment terminal. The reference voltage is expressed across $R1$ and, since the voltage is constant, a constant current I_1 then flows through $R2$, giving an output voltage of:

$$V_{OUT} = V_{REF} \left(1 + \frac{R2}{R1} \right) + I_{ADJ}R2 \quad (1)$$

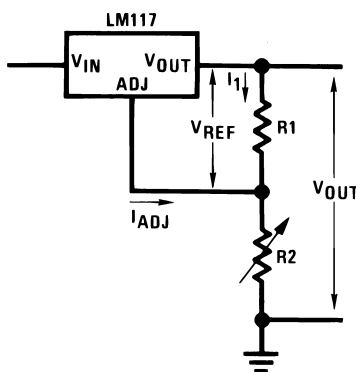

Since the 100- μ A current from the adjustment terminal represents an error term, the LM117HVQML-SP was designed to minimize I_{ADJ} and make it very constant with line and load changes. To do this, all quiescent operating current is returned to the output establishing a minimum load current requirement. If there is insufficient load on the output, the output will rise.

To mitigate the requirement for an added load to sink the required output current, the resistor divider may be selected so that it alone can sink the largest specified output load current of 5 mA (nominal). This has the additional benefit of minimizing the I_{ADJ} error term (which varies over temperature).

8.3.2 Load Regulation

The LM117HVQML-SP is capable of providing extremely good load regulation but a few precautions are needed to obtain maximum performance. The current set resistor connected between the adjustment terminal and the output terminal (usually 240 Ω) should be tied directly to the output (case) of the regulator rather than near the load. This eliminates line drops from appearing effectively in series with the reference and degrading regulation. For example, a 15-V regulator with 0.05- Ω resistance between the regulator and load will have a load regulation due to line resistance of $0.05 \Omega \times I_L$. If the set resistor is connected near the load the effective line resistance will be $0.05 \Omega (1 + R2 / R1)$ or in this case, 11.5 times worse.

Figure 8-1 shows the effect of resistance between the regulator and 240- Ω set resistor.

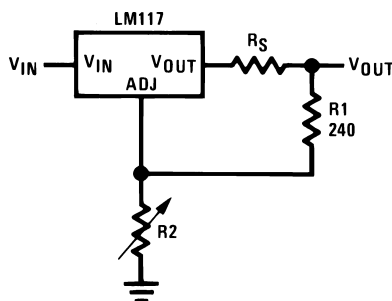

Figure 8-1. Regulator With Line Resistance in Output Lead

With the TO-39 package, care should be taken to minimize the wire length of the output lead. The ground of $R2$ can be returned near the ground of the load to provide remote ground sensing and improve load regulation.

8.3.3 External Capacitors

An input bypass capacitor is recommended. A 0.1- μF disc or 1- μF solid tantalum on the input is suitable input bypassing for almost all applications. The device is more sensitive to the absence of input bypassing when adjustment or output capacitors are used but the above values will eliminate the possibility of problems.

The adjustment terminal can be bypassed to ground on the LM117HVQML-SP to improve ripple rejection. This bypass capacitor prevents ripple from being amplified as the output voltage is increased. With a 10- μF bypass capacitor 80-dB ripple rejection is obtainable at any output level. Increases over 10- μF do not appreciably improve the ripple rejection at frequencies above 120 Hz. If the bypass capacitor is used, it is sometimes necessary to include protection diodes to prevent the capacitor from discharging through internal low current paths and damaging the device (see Section 8.3.4).

In general, the best type of capacitors to use are solid tantalum. Solid tantalum capacitors have low impedance even at high frequencies. Depending upon capacitor construction, it takes about 25- μF in aluminum electrolytic to equal 1- μF solid tantalum at high frequencies. Ceramic capacitors are also good at high frequencies; but some types have a large decrease in capacitance at frequencies around 0.5 MHz. For this reason, 0.01- μF disc may seem to work better than a 0.1- μF disc as a bypass.

Although the LM117HVQML-SP is stable with no output capacitors, like any feedback circuit, certain values of external capacitance can cause excessive ringing. This occurs with values between 500 pF and 5000 pF. A 1- μF solid tantalum (or 25- μF aluminum electrolytic) on the output swamps this effect and insures stability. Any increase of the load capacitance larger than 10 μF will merely improve the loop stability and output impedance.

8.3.4 Protection Diodes

When external capacitors are used with an IC regulator it is sometimes necessary to add protection diodes to prevent the capacitors from discharging through low current points into the regulator. Most 10- μF capacitors have low enough internal series resistance to deliver 20-A spikes when shorted. Although the surge is short, there is enough energy to damage parts of the IC.

When an output capacitor is connected to a regulator and the input is shorted, the output capacitor will discharge into the output of the regulator. The discharge current depends on the value of the capacitor, the output voltage of the regulator, and the rate of decrease of V_{IN} . In the LM117HVQML-SP, this discharge path is through a large junction that is able to sustain 15-A surge. This is not true of other types of positive regulators. For output capacitors of 25 μF or less, there is no need to use diodes.

The bypass capacitor on the adjustment terminal can discharge through a low current junction. Discharge occurs when *either* the input or output is shorted. Internal to the LM117HVQML-SP is a 50- Ω resistor which limits the peak discharge current. No protection is needed for output voltages of 25 V or less and 10- μF capacitance. Figure 8-2 shows an LM117HVQML-SP with protection diodes included for use with outputs greater than 25 V and high values of output capacitance.

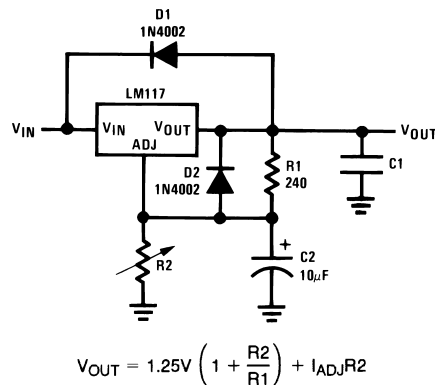

- D1 protects against C1 (such as due to a V_{IN} short),
- D2 protects against C2 (Such as due to a V_{OUT} short).

Figure 8-2. Regulator With Protection Diodes

9 Application and Implementation

Note

Information in the following applications sections is not part of the TI component specification, and TI does not warrant its accuracy or completeness. TI's customers are responsible for determining suitability of components for their purposes, as well as validating and testing their design implementation to confirm system functionality.

9.1 Typical Applications

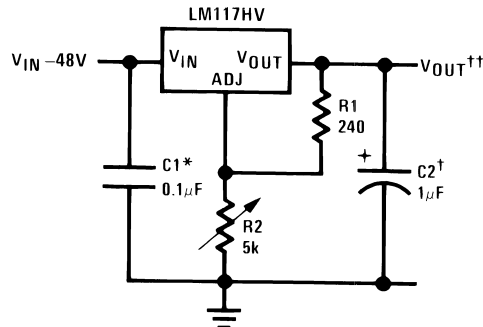

Full output current not available at high input-output voltages

†Optional—improves transient response. Output capacitors in the range of 1 µF to 1000 µF of aluminum or tantalum electrolytic are commonly used to provide improved output impedance and rejection of transients.

*Needed if device is more than 6 in from filter capacitors.

$$\dagger\dagger V_{OUT} = 1.25V \left(1 + \frac{R2}{R1} \right) + I_{ADJ} R2$$

Figure 9-1. 1.2-V-45-V Adjustable Regulator

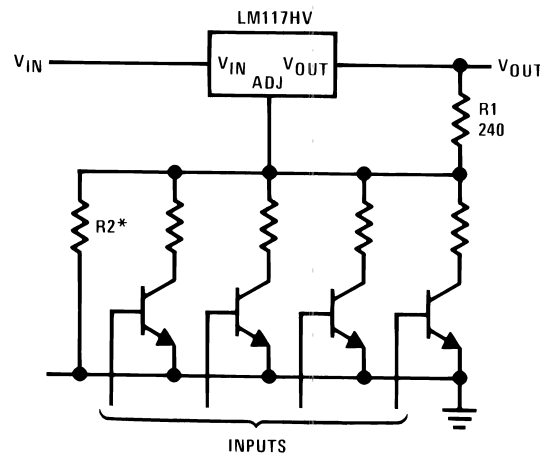

*Sets maximum V_{OUT}

Figure 9-2. Digitally Selected Outputs

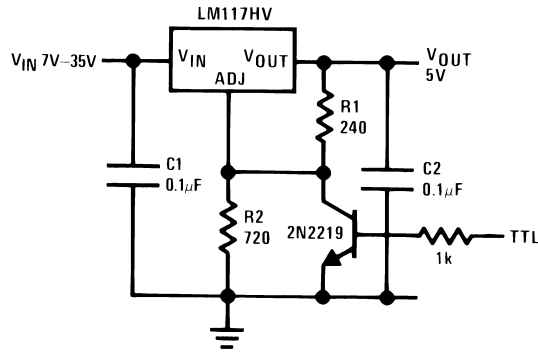

*Min. output \approx 1.2 V

Figure 9-3. 5-V Logic Regulator With Electronic Shutdown*

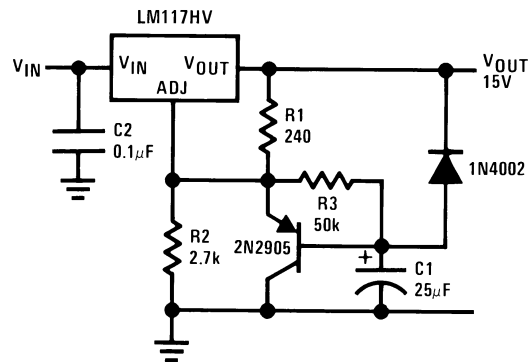
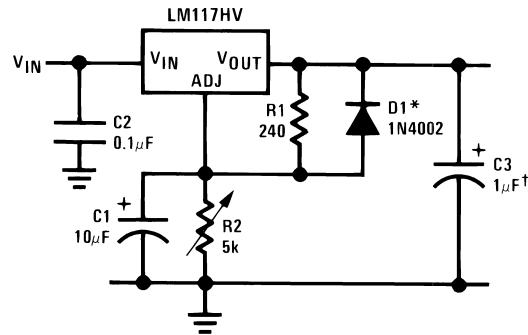

Figure 9-4. Slow Turn-On 15-V Regulator



†Solid tantalum

*Discharges C1 if output is shorted to ground

Figure 9-5. Adjustable Regulator With Improved Ripple Rejection

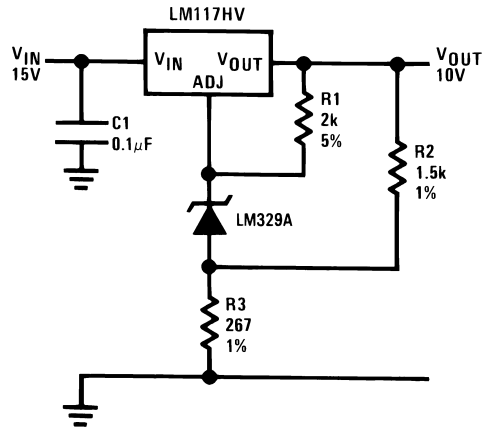
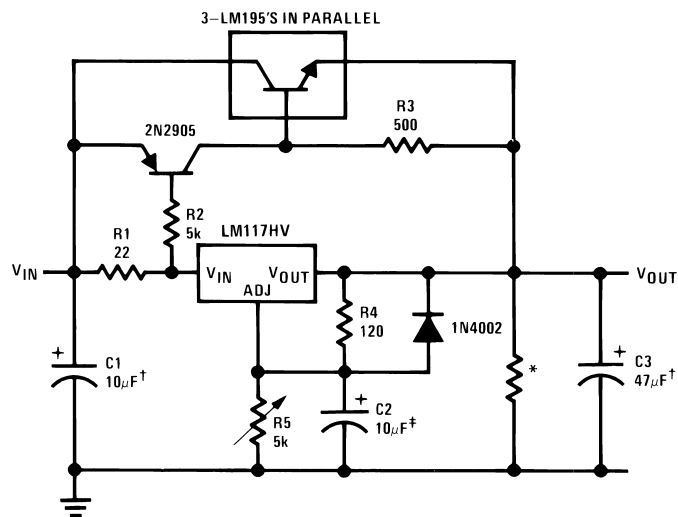

Figure 9-6. High Stability 10-V Regulator



†Solid tantalum

*Minimum load current = 30 mA

‡Optional—improves ripple rejection

Figure 9-7. High Current Adjustable Regulator

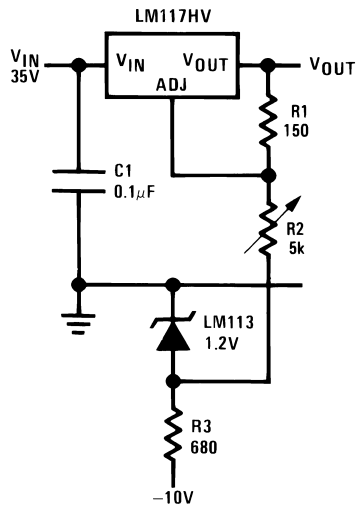

Full output current not available at high input-output voltages

Figure 9-8. 0-V to 30-V Regulator

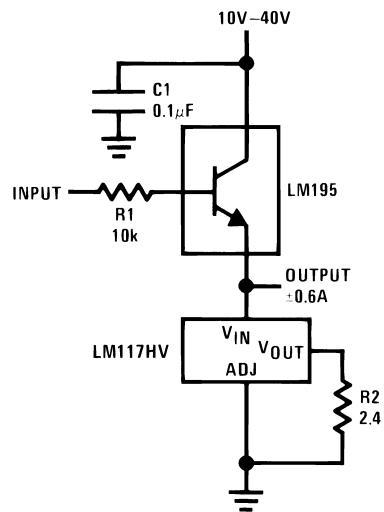
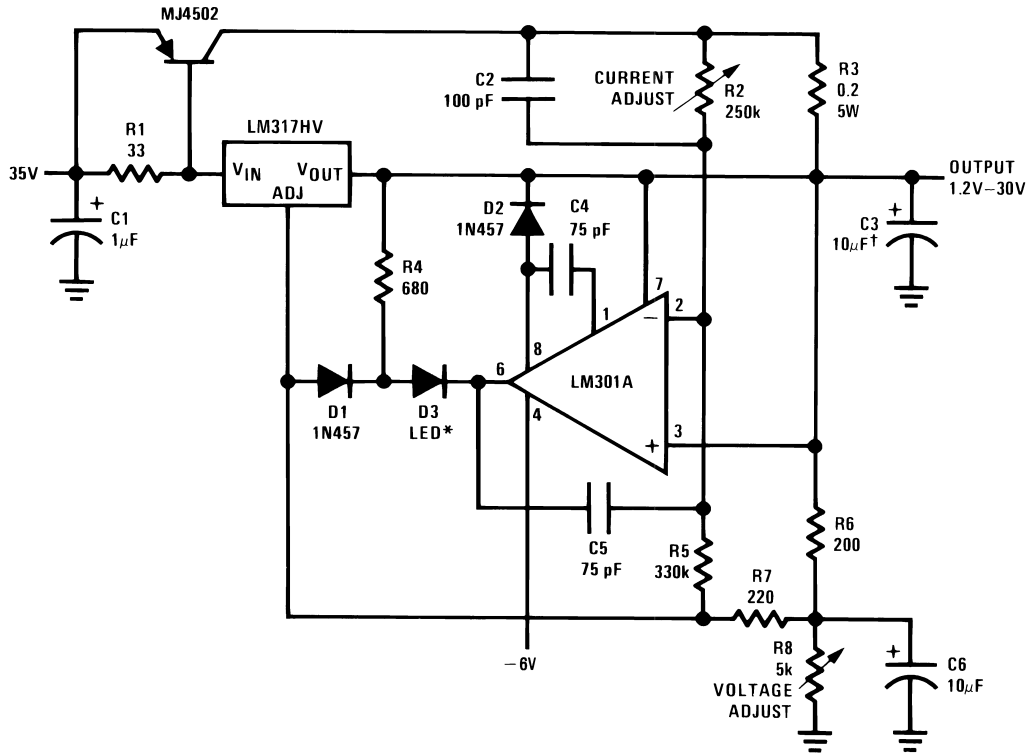

Figure 9-9. Power Follower



†Solid tantalum

*Lights in constant current mode

Figure 9-10. 5-A Constant Voltage/Constant Current Regulator

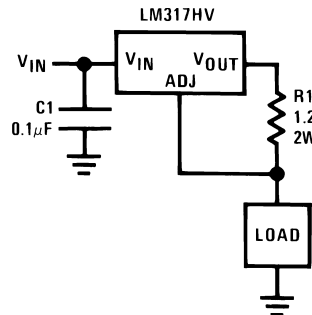
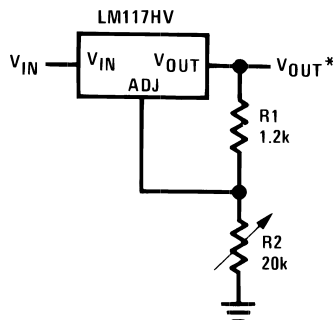

Figure 9-11. 1-A Current Regulator



*Minimum load current \approx 5 mA

Figure 9-12. 1.2-V-20-V Regulator With Minimum Program Current

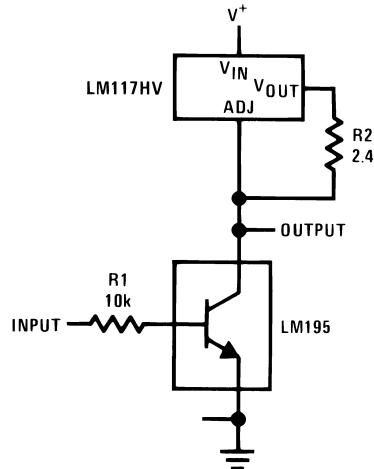
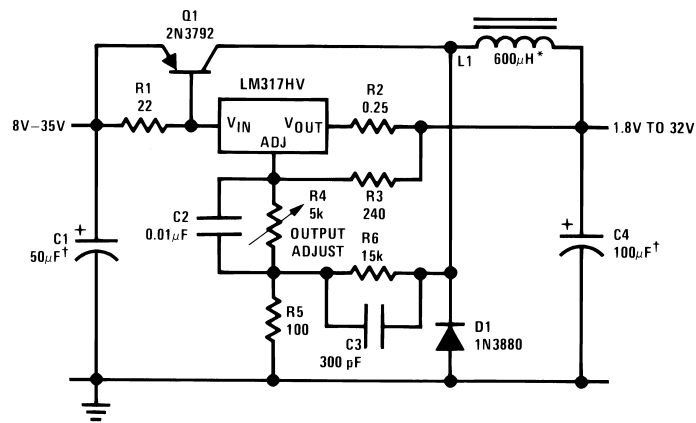

Figure 9-13. High Gain Amplifier



†Solid tantalum

*Core—Arnold A-254168-2 60 turns

Figure 9-14. Low Cost 3-A Switching Regulator

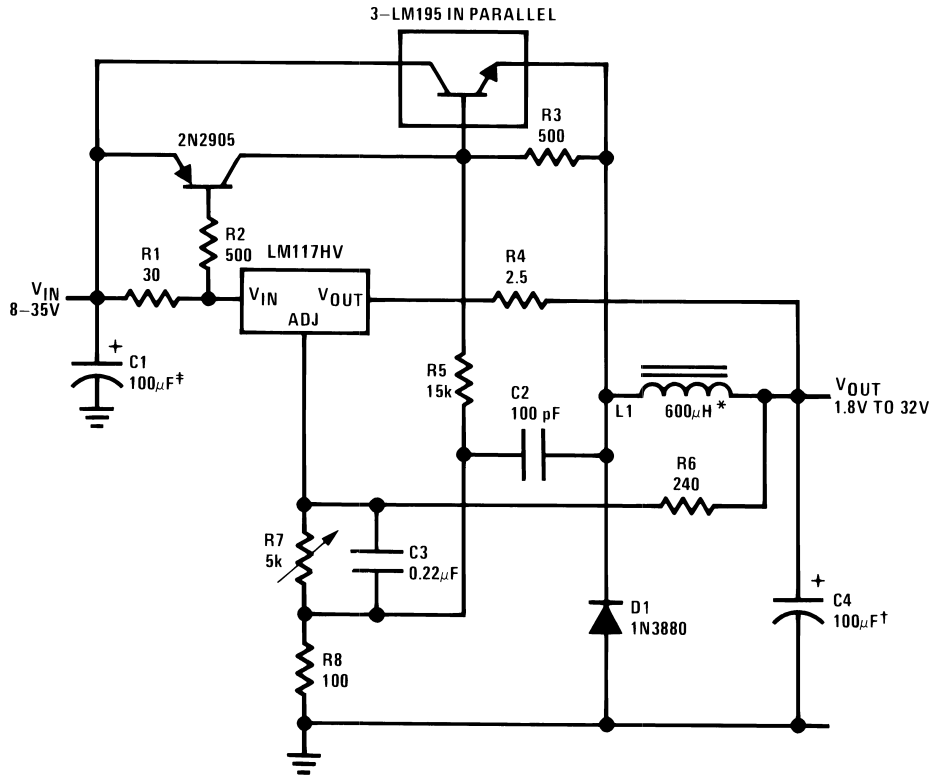

†Solid tantalum

*Core—Arnold A-254168-2 60 turns

Figure 9-15. 4-A Switching Regulator With Overload Protection

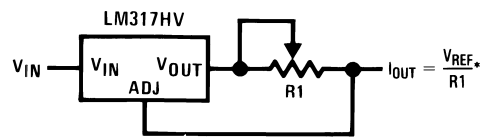

* $0.8 \Omega \leq R1 \leq 120 \Omega$

Figure 9-16. Precision Current Limiter

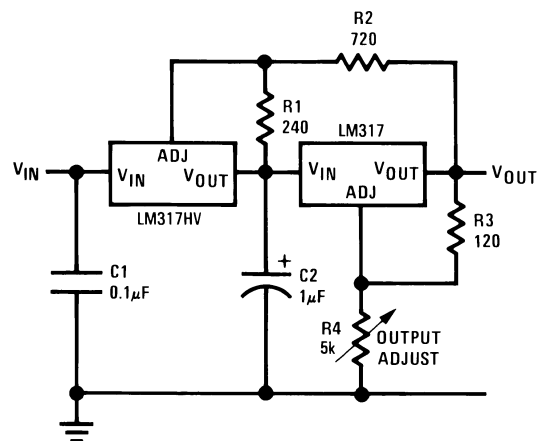
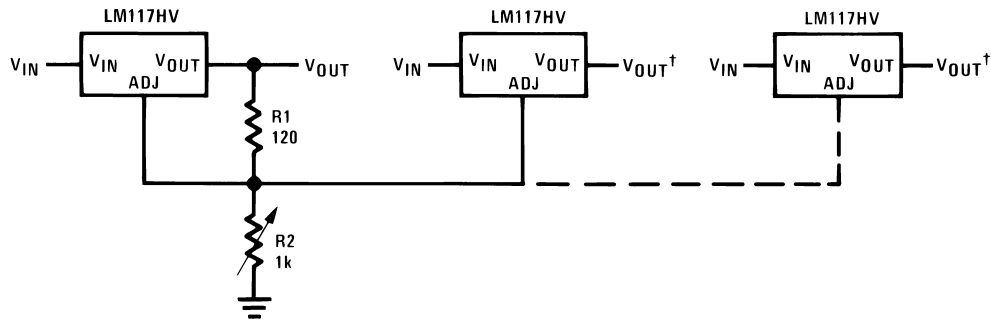

Figure 9-17. Tracking Preregulator



*All outputs within ± 100 mV

†Minimum load = 10 mA

Figure 9-18. Adjustable Multiple On-card Regulators With Single Control*

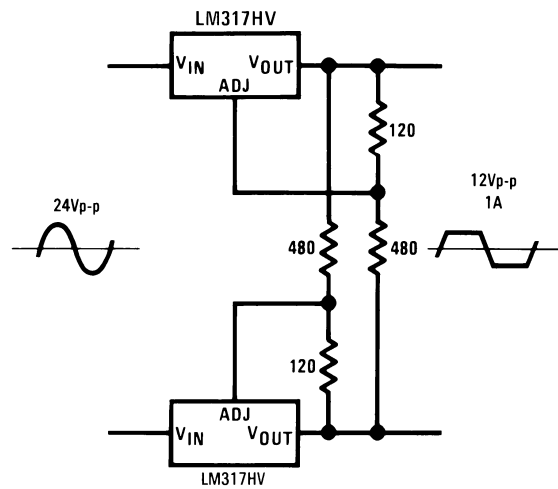
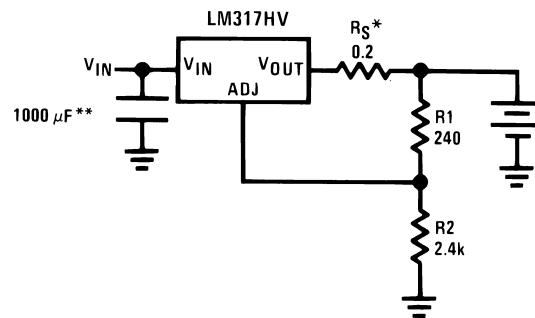

Figure 9-19. AC Voltage Regulator



$$*R_S \text{—sets output impedance of charger } Z_{OUT} = R_S \left(1 + \frac{R_2}{R_1} \right)$$

Use of R_S allows low charging rates with fully charged battery.

**The 1000 μ F is recommended to filter out input transients

Figure 9-20. 12-V Battery Charger

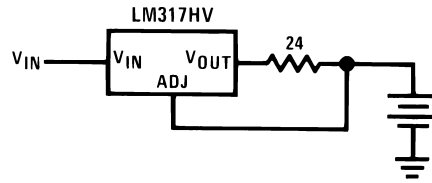

Figure 9-21. 50-mA Constant Current Battery Charger

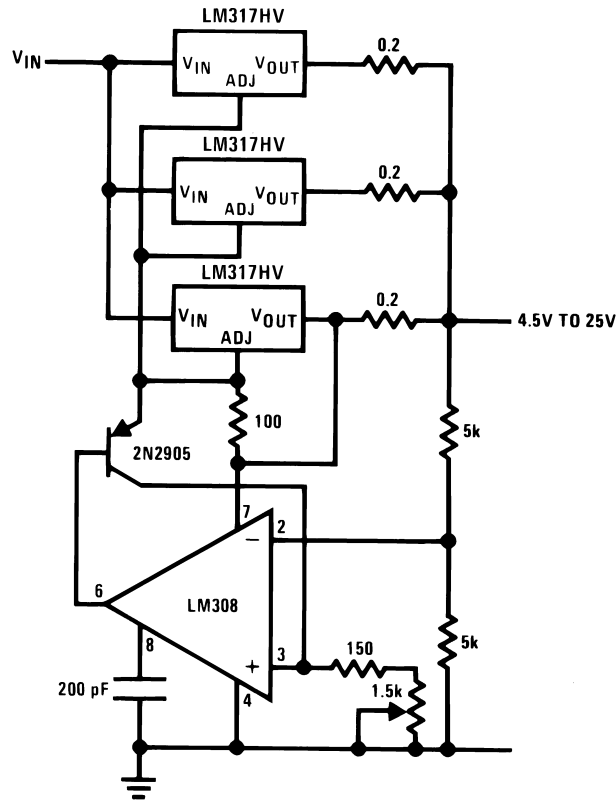
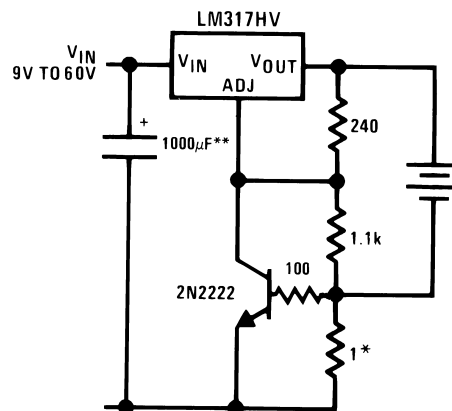

Figure 9-22. Adjustable 4-A Regulator



*Sets peak current (0.6 A for 1 Ω)

**The 1000 µF is recommended to filter out input transients

Figure 9-23. Current Limited 6-V Charger

10 Power Supply Recommendations

The input supply to the LM117HVQML-SP must be kept at a voltage level such that its maximum input to output differential voltage is not exceeded. The minimum dropout voltage must also be met with extra headroom when possible to keep the LM117HVQML-SP in regulation. An input capacitor is recommended, especially when the input pin is located more than 6 in away from the power supply source. For more information regarding capacitor selection, refer to [External Capacitors](#).

11 Layout

11.1 Layout Guidelines

Ensure wide enough traces for those carrying the load current in order to reduce the amount of parasitic trace inductance. Keep the feedback loop from VOUT to ADJ as short as possible. To improve PSRR, a bypass capacitor can be placed at the ADJ pin and must be located as close as possible to the IC. In cases when VIN shorts to ground, an external diode must be placed from VOUT to VIN to divert the surge current from the output capacitor and protect the IC. Similarly, in cases when a large bypass capacitor is placed at the ADJ pin and VOUT shorts to ground, an external diode must be placed from ADJ to VOUT to provide a path for the bypass capacitor to discharge. These diodes must be placed close to the corresponding LM117HVQML-SP pins to increase their effectiveness.

12 Device and Documentation Support

12.1 Device Support

12.1.1 Third-Party Products Disclaimer

TI'S PUBLICATION OF INFORMATION REGARDING THIRD-PARTY PRODUCTS OR SERVICES DOES NOT CONSTITUTE AN ENDORSEMENT REGARDING THE SUITABILITY OF SUCH PRODUCTS OR SERVICES OR A WARRANTY, REPRESENTATION OR ENDORSEMENT OF SUCH PRODUCTS OR SERVICES, EITHER ALONE OR IN COMBINATION WITH ANY TI PRODUCT OR SERVICE.

12.2 Documentation Support

12.2.1 Related Documentation

1. [LM117HVQML-SP NDD \(Neutron Displacement Damage\) Characterization](#)
2. [LM117HVQML-SP SMD 5962R0722961V9A](#)
3. [Die Datasheet LM117HVKG MD8 3-Terminal Adj Regulator](#)
4. [High Reliability Part Numbering System](#)
5. [Applications for an Adjustable IC Power Regulator](#)
6. [Improving Power Supply Reliability with IC Power Regulators](#)
7. [A New Production Technique for Trimming Voltage Regulators](#)
8. [LDO basics: capacitor vs. capacitance](#)
9. [LDO Basics: Preventing reverse current](#)

12.3 Receiving Notification of Documentation Updates

To receive notification of documentation updates, navigate to the device product folder on [ti.com](#). Click on *Subscribe to updates* to register and receive a weekly digest of any product information that has changed. For change details, review the revision history included in any revised document.

12.4 Support Resources

[TI E2E™ support forums](#) are an engineer's go-to source for fast, verified answers and design help — straight from the experts. Search existing answers or ask your own question to get the quick design help you need.

Linked content is provided "AS IS" by the respective contributors. They do not constitute TI specifications and do not necessarily reflect TI's views; see TI's [Terms of Use](#).

12.5 Trademarks

TI E2E™ is a trademark of Texas Instruments.
All trademarks are the property of their respective owners.

12.6 Electrostatic Discharge Caution



This integrated circuit can be damaged by ESD. Texas Instruments recommends that all integrated circuits be handled with appropriate precautions. Failure to observe proper handling and installation procedures can cause damage.

ESD damage can range from subtle performance degradation to complete device failure. Precision integrated circuits may be more susceptible to damage because very small parametric changes could cause the device not to meet its published specifications.

12.7 Glossary

[TI Glossary](#) This glossary lists and explains terms, acronyms, and definitions.

13 Mechanical, Packaging, and Orderable Information

The following pages include mechanical, packaging, and orderable information. This information is the most current data available for the designated devices. This data is subject to change without notice and revision of this document. For browser-based versions of this data sheet, refer to the left-hand navigation.

PACKAGING INFORMATION

Orderable Device	Status (1)	Package Type	Package Drawing	Pins	Package Qty	Eco Plan (2)	Lead finish/ Ball material (6)	MSL Peak Temp (3)	Op Temp (°C)	Device Marking (4/5)	Samples
5962R0722901V9A	ACTIVE	DIESALE	Y	0	42	RoHS & Green	Call TI	Level-1-NA-UNLIM	-55 to 125		Samples
5962R0722901VXA	ACTIVE	TO	NDT	3	20	Non-RoHS & Non-Green	Call TI	Call TI	-55 to 125	LM117HVHRQMLV 5962R0722901VXA Q ACO 5962R0722901VXA Q >T	Samples
5962R0722902VXA	ACTIVE	TO	NDT	3	20	Non-RoHS & Non-Green	Call TI	Call TI	-55 to 125	LM117HVHRLQMLV 5962R0722961VXA Q ACO 5962R0722961VXA Q >T	Samples
5962R0722902VZA	ACTIVE	CFP	NAC	16	42	Non-RoHS & Green	Call TI	Level-1-NA-UNLIM	-55 to 125	LM117HVGWR QMLV Q 5962R07229 02VZA ACO 02VZA >T	Samples
5962R0722961V9A	ACTIVE	DIESALE	Y	0	42	RoHS & Green	Call TI	Level-1-NA-UNLIM	-55 to 125		Samples
5962R0722961VXA	ACTIVE	TO	NDT	3	20	Non-RoHS & Non-Green	Call TI	Call TI	-55 to 125	LM117HVHRLQMLV 5962R0722961VXA Q ACO 5962R0722961VXA Q >T	Samples
5962R0722962VZA	ACTIVE	CFP	NAC	16	42	Non-RoHS & Green	Call TI	Level-1-NA-UNLIM	-55 to 125	LM117HVGWRL QMLV Q 5962R07229 62VZA ACO 62VZA >T	Samples
LM117HVGWRLQMLV	ACTIVE	CFP	NAC	16	42	Non-RoHS & Green	Call TI	Level-1-NA-UNLIM	-55 to 125	LM117HVGWRL QMLV Q 5962R07229 62VZA ACO 62VZA >T	Samples
LM117HVGWRQMLV	ACTIVE	CFP	NAC	16	42	Non-RoHS & Green	Call TI	Level-1-NA-UNLIM	-55 to 125	LM117HVGWR QMLV Q 5962R07229	Samples

Orderable Device	Status (1)	Package Type	Package Drawing	Pins	Package Qty	Eco Plan (2)	Lead finish/ Ball material (6)	MSL Peak Temp (3)	Op Temp (°C)	Device Marking (4/5)	Samples
										02VZA ACO 02VZA >T	
LM117HVH MDE	ACTIVE	DIESALE	Y	0	42	RoHS & Green	Call TI	Level-1-NA-UNLIM	-55 to 125		Samples
LM117HVH MDR	ACTIVE	DIESALE	Y	0	42	RoHS & Green	Call TI	Level-1-NA-UNLIM	-55 to 125		Samples
LM117HVHRLQMLV	ACTIVE	TO	NDT	3	20	Non-RoHS & Green	Call TI	Level-1-NA-UNLIM	-55 to 125	LM117HVHRLQMLV 5962R0722961VXA Q ACO 5962R0722961VXA Q >T	Samples
LM117HVHRQMLV	ACTIVE	TO	NDT	3	20	Non-RoHS & Green	Call TI	Level-1-NA-UNLIM	-55 to 125	LM117HVHRQMLV 5962R0722901VXA Q ACO 5962R0722901VXA Q >T	Samples
LM117HVNAC/EM	ACTIVE	CFP	NAC	16	42	Non-RoHS & Green	Call TI	Level-1-NA-UNLIM	25 to 25	LM117HVNAC/EM EVAL ONLY T	Samples

(1) The marketing status values are defined as follows:

ACTIVE: Product device recommended for new designs.

LIFEBUY: TI has announced that the device will be discontinued, and a lifetime-buy period is in effect.

NRND: Not recommended for new designs. Device is in production to support existing customers, but TI does not recommend using this part in a new design.

PREVIEW: Device has been announced but is not in production. Samples may or may not be available.

OBSOLETE: TI has discontinued the production of the device.

(2) **RoHS:** TI defines "RoHS" to mean semiconductor products that are compliant with the current EU RoHS requirements for all 10 RoHS substances, including the requirement that RoHS substance do not exceed 0.1% by weight in homogeneous materials. Where designed to be soldered at high temperatures, "RoHS" products are suitable for use in specified lead-free processes. TI may reference these types of products as "Pb-Free".

RoHS Exempt: TI defines "RoHS Exempt" to mean products that contain lead but are compliant with EU RoHS pursuant to a specific EU RoHS exemption.

Green: TI defines "Green" to mean the content of Chlorine (Cl) and Bromine (Br) based flame retardants meet JS709B low halogen requirements of <=1000ppm threshold. Antimony trioxide based flame retardants must also meet the <=1000ppm threshold requirement.

(3) MSL, Peak Temp. - The Moisture Sensitivity Level rating according to the JEDEC industry standard classifications, and peak solder temperature.

(4) There may be additional marking, which relates to the logo, the lot trace code information, or the environmental category on the device.

(5) Multiple Device Markings will be inside parentheses. Only one Device Marking contained in parentheses and separated by a "-" will appear on a device. If a line is indented then it is a continuation of the previous line and the two combined represent the entire Device Marking for that device.

(6) Lead finish/Ball material - Orderable Devices may have multiple material finish options. Finish options are separated by a vertical ruled line. Lead finish/Ball material values may wrap to two lines if the finish value exceeds the maximum column width.

Important Information and Disclaimer:The information provided on this page represents TI's knowledge and belief as of the date that it is provided. TI bases its knowledge and belief on information provided by third parties, and makes no representation or warranty as to the accuracy of such information. Efforts are underway to better integrate information from third parties. TI has taken and continues to take reasonable steps to provide representative and accurate information but may not have conducted destructive testing or chemical analysis on incoming materials and chemicals. TI and TI suppliers consider certain information to be proprietary, and thus CAS numbers and other limited information may not be available for release.

In no event shall TI's liability arising out of such information exceed the total purchase price of the TI part(s) at issue in this document sold by TI to Customer on an annual basis.

OTHER QUALIFIED VERSIONS OF LM117HVQML-SP :

- Military : [LM117HVQML](#)

NOTE: Qualified Version Definitions:

- Military - QML certified for Military and Defense Applications

TRAY

Chamfer on Tray corner indicates Pin 1 orientation of packed units.

*All dimensions are nominal

Device	Package Name	Package Type	Pins	SPQ	Unit array matrix	Max temperature (°C)	L (mm)	W (mm)	K0 (µm)	P1 (mm)	CL (mm)	CW (mm)
5962R0722901VXA	NDT	TO-CAN	3	20	2 X 10	150	126.49	61.98	8890	11.18	12.95	18.54
5962R0722902VXA	NDT	TO-CAN	3	20	2 X 10	150	126.49	61.98	8890	11.18	12.95	18.54
5962R0722902VZA	NAC	CFP	16	42	7 X 6	NA	101.6	101.6	8001	2.84	15.24	15.24
5962R0722961V9A	Y	DIESALE	0	42	14 x 14	70	2.54	2.54	410	2.92	6.41	6.41
5962R0722961VXA	NDT	TO-CAN	3	20	2 X 10	150	126.49	61.98	8890	11.18	12.95	18.54
5962R0722962VZA	NAC	CFP	16	42	7 X 6	NA	101.6	101.6	8001	2.84	15.24	15.24
LM117HVGWRLQMLV	NAC	CFP	16	42	7 X 6	NA	101.6	101.6	8001	2.84	15.24	15.24
LM117HVGWRQMLV	NAC	CFP	16	42	7 X 6	NA	101.6	101.6	8001	2.84	15.24	15.24
LM117HVH MDE	Y	DIESALE	0	42	14 x 14	70	2.54	2.54	410	2.92	6.41	6.41
LM117HVHRLQMLV	NDT	TO-CAN	3	20	2 X 10	150	126.49	61.98	8890	11.18	12.95	18.54
LM117HVHRQMLV	NDT	TO-CAN	3	20	2 X 10	150	126.49	61.98	8890	11.18	12.95	18.54
LM117HVNAC/EM	NAC	CFP	16	42	7 X 6	NA	101.6	101.6	8001	2.84	15.24	15.24

EXAMPLE BOARD LAYOUT

NAC0016A

CFP - 2.33mm max height

CERAMIC FLATPACK

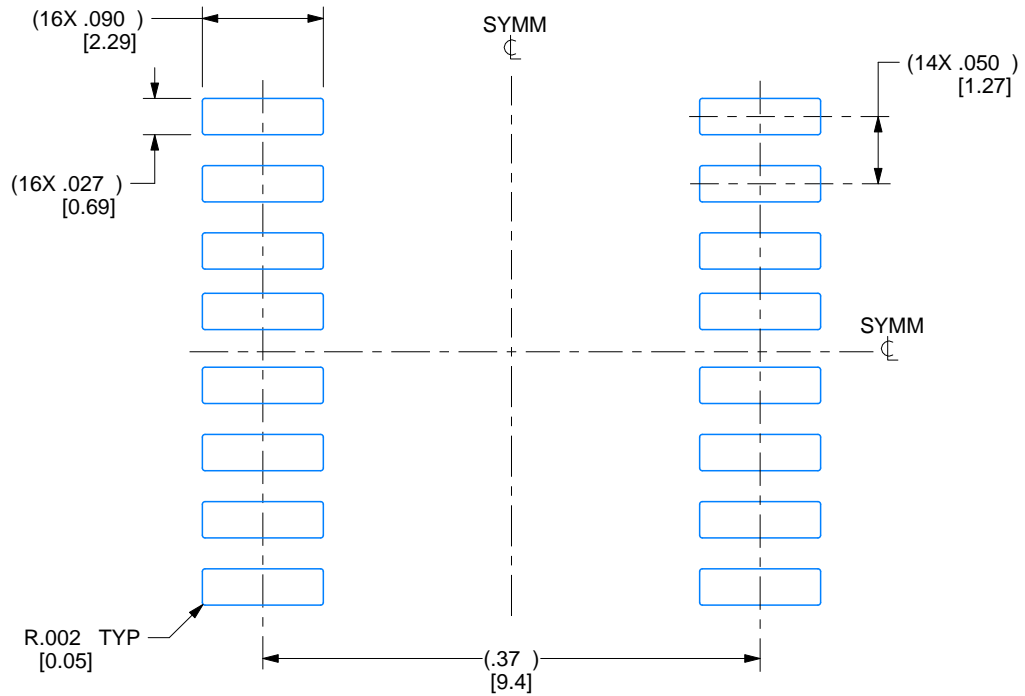

RECOMMENDED LAND PATTERN

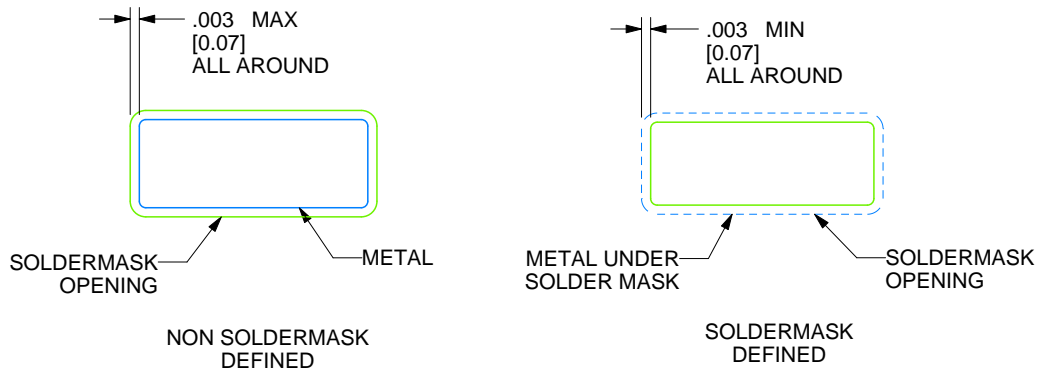

4215198/C 08/2022

REVISIONS

REV	DESCRIPTION	E.C.N.	DATE	BY/APP'D
A	RELEASE TO DOCUMENT CONTROL	2197879	12/30/2021	TINA TRAN / ANIS FAUZI
B	NO CHANGE TO DRAWING; REVISION FOR YODA RELEASE;	2198832	02/15/2022	K. SINCERBOX
C	.387± .003 WAS .39000± .00012;	2200917	08/08/2022	D. CHIN / K. SINCERBOX

NDT0003A

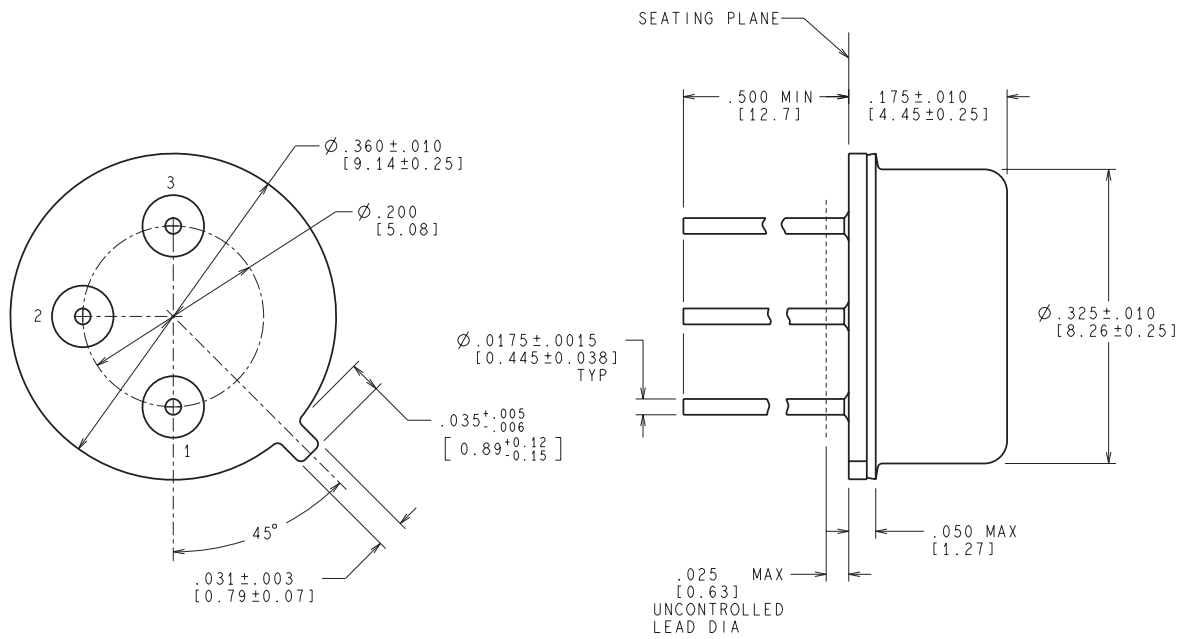

CONTROLLING DIMENSION IS INCH
VALUES IN [] ARE MILLIMETERS

MIL-PRF-38535
CONFIGURATION CONTROL

H03A (Rev D)

IMPORTANT NOTICE AND DISCLAIMER

TI PROVIDES TECHNICAL AND RELIABILITY DATA (INCLUDING DATA SHEETS), DESIGN RESOURCES (INCLUDING REFERENCE DESIGNS), APPLICATION OR OTHER DESIGN ADVICE, WEB TOOLS, SAFETY INFORMATION, AND OTHER RESOURCES "AS IS" AND WITH ALL FAULTS, AND DISCLAIMS ALL WARRANTIES, EXPRESS AND IMPLIED, INCLUDING WITHOUT LIMITATION ANY IMPLIED WARRANTIES OF MERCHANTABILITY, FITNESS FOR A PARTICULAR PURPOSE OR NON-INFRINGEMENT OF THIRD PARTY INTELLECTUAL PROPERTY RIGHTS.

These resources are intended for skilled developers designing with TI products. You are solely responsible for (1) selecting the appropriate TI products for your application, (2) designing, validating and testing your application, and (3) ensuring your application meets applicable standards, and any other safety, security, regulatory or other requirements.

These resources are subject to change without notice. TI grants you permission to use these resources only for development of an application that uses the TI products described in the resource. Other reproduction and display of these resources is prohibited. No license is granted to any other TI intellectual property right or to any third party intellectual property right. TI disclaims responsibility for, and you will fully indemnify TI and its representatives against, any claims, damages, costs, losses, and liabilities arising out of your use of these resources.

TI's products are provided subject to [TI's Terms of Sale](#) or other applicable terms available either on ti.com or provided in conjunction with such TI products. TI's provision of these resources does not expand or otherwise alter TI's applicable warranties or warranty disclaimers for TI products.

TI objects to and rejects any additional or different terms you may have proposed.

Mailing Address: Texas Instruments, Post Office Box 655303, Dallas, Texas 75265
Copyright © 2022, Texas Instruments Incorporated