

# The forgotten converter



**Greg Lubarsky**

*Systems Engineer  
Silicon Valley Analog  
Mobile Lighting and Power  
Texas Instruments*

# Charge pumps can provide a DC/DC converter solution that is easy to implement in a small PCB footprint.

---

In the world of analog power-supply design, the inductive DC/DC converter and low-dropout (LDO) regulator are often thought of as key building blocks. While it is true that the high efficiency of inductive converters and the simplicity of LDOs are attractive when attacking a design, another type of converter exists that falls in the middle of these approaches.

A charge pump or switched-capacitor converter is a kind of switching regulator that delivers power by charging and discharging capacitors. While perhaps not as efficient as an inductive-based converter, a charge pump provides ease of use, small solution size and ruggedness not found in the inductive alternative.

Charge-pump devices come in boost, buck and inverting flavors (just like their magnetic brethren) without the cost and inductor printed circuit board (PCB) area requirements.

This white paper discusses the pros and cons of charge-pump converter topologies, provides industrial and personal electronics application examples, and covers component-selection guidelines.

---

## Charge-pump basics

### Operation

Through the use of a few small and inexpensive external capacitors, a charge-pump converter can convert one DC voltage just like a magnetic DC/DC converter. By creatively charging and discharging the switching capacitor (also called a flying capacitor) through the connection of an array of internal MOSFET switches, a charge pump provides a suitable solution for applications with low-load currents (under 250 mA) and moderate input-to-output voltage differences (5.5 V to 2.7 V typical). By manipulating the capacitor connections, you can realize a number of input-voltage gains to create the desired output voltage. Depending on the architecture, the output can be regulated (example: +5 V or +1.8 V) or unregulated ( $V_{OUT} = V_{IN} * GAIN$ ).

### *Inductive versus capacitive converter*

Charge-pump gains are fixed, and the number of gains is limited by the number of switching capacitors and on-chip switches. The gain quantization causes the input current drawn from the supply to be equal to the charge-pump gain multiplied by load current. This is in contrast to an inductive DC/DC converter, where you can manipulate the input-to-output voltage gain by adjusting the duty cycle of operation to a very wide range.

When looking at efficiency curves and comparing the two types of converters, a typical charge-pump converter has a sawtooth shape as the input voltage changes, while the magnetic boost has a nearly flat-line profile. From a power perspective, the inductive-based solution is usually more efficient than the charge-pump solution. Over a typical

input-voltage range (5.5 V to 2.7 V), the average efficiency of a charge pump is around 70 percent at higher currents, whereas the inductive solution is in the mid-80 percent range and often peaks in the low 90 percent range (Figure 1).

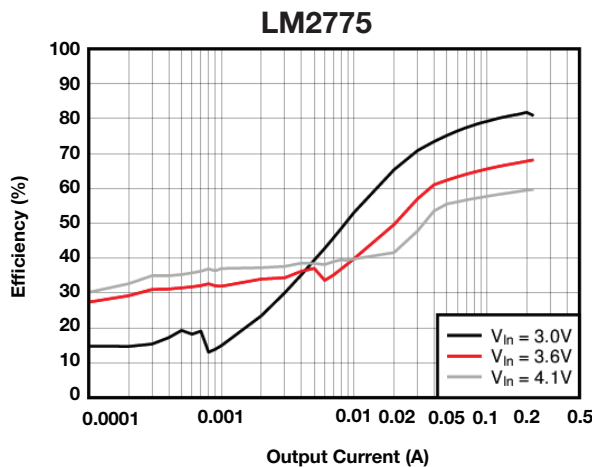
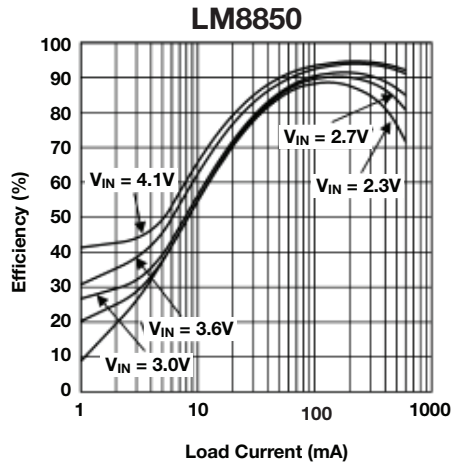

Figure 1. The efficiency of a charge pump (bottom) is 70 percent versus an inductive solution (top) with efficiency in the mid-80 percent range, with peaks often in the low 90 percent range.

Without the need for an inductor or the strict layout requirements inherent to inductive solutions, the charge-pump solution can have a smaller PCB layout, while still meeting the load requirements. By eliminating the inductor, it is also possible to save the “z” height (thickness) of the design.

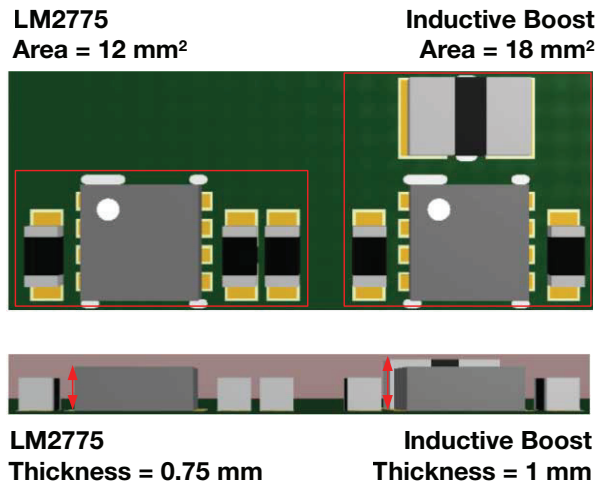

Figure 2. This image demonstrates how much smaller a charge-pump solution (left) is than an induction solution (right).

In Figure 2, the LM2775 charge-pump solution is significantly smaller than the inductive solution because the inductor is omitted. The charge-pump solution is also thinner, with the LM2775 package setting the maximum thickness (0.75 mm) versus an inductive solution where the inductor sets the thickness (1 mm).

## Charge-pump architectures

### Charge-pump boost

The most fundamental charge-pump converter is the boost, while the charge-pump doubler is the most basic of boost configurations. In this topology, the switching capacitor is charged from the input voltage to ground in the first phase, and then connected between the input voltage and output voltage. Stacking the capacitor creates an output voltage double that of the input voltage (Figure 3).

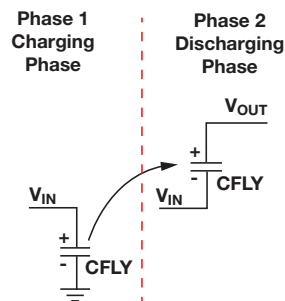

Figure 3. The stacking capacitor creates an output voltage that is double the input voltage.

As a byproduct of the output voltage doubling, the input current also doubles, regardless of the input voltage. This is in contrast to a magnetic DC/DC converter where the input current is not a fixed-gain value of the output current, but rather scales based on the input-to-output voltage ratio. Charge-pump doublers are available in regulated and unregulated versions, depending on the architecture and output-voltage requirement.

### Unregulated doubler

In the unregulated doubler case, the output voltage can be modeled as an ideal gain stage, followed by a series resistor representing the charge pump's output impedance ( $R_{OUT}$ ) (Figure 4).

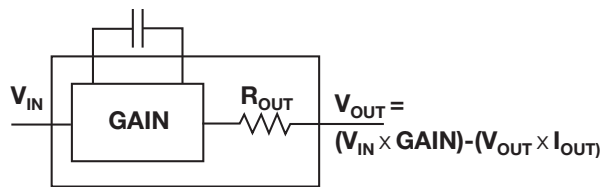

Figure 4. For an unregulated doubler,  $GAIN = 2$ .

With an unregulated charge pump, the output voltage droops, based on the load current drawn and the device's output resistance ( $R_{OUT}$ ). The value of  $R_{OUT}$  also varies from device to device.  $R_{OUT}$  is made up of a switch-resistance component; a switching-frequency and switching-capacitance component; and to a lesser extent, a capacitor-equivalent series resistance (ESR) component. (With the industrywide usage of ceramic capacitors, the  $E_{SR}$  component has become almost negligible.) As the  $R_{OUT}$  value decreases, the charge-pump droop decreases.

### Pre-regulated doubler

With a regulated charge-pump doubler, the basic device model changes (Figure 5).

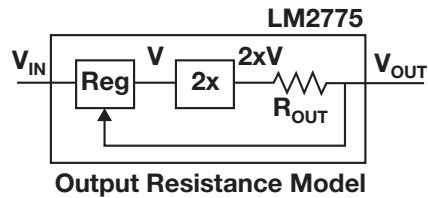

Figure 5. Pre-regulation adds a feedback loop to the open-loop charge pump.

To maintain output-voltage regulation, you can implement a control scheme using feedback from the output to manipulate the voltage placed on the switching capacitor during the charging phase. You can control this regulation by either adjusting the charge current into the capacitor via a current source, or by modulating the impedance of the input-connected MOSFET switch. With pre-regulation, the output voltage becomes regulated and the output ripple droops.

### Multicapacitor/multigain boost

In cases that require higher efficiency, select a part that uses multiple gains. To achieve more than a single gain, you can use additional switching capacitors. Moving to two capacitors from one allows for the creation of an input voltage multiplier gain of one and a half, allowing the device to become more efficient over the input operating range when the desired input-to-output voltage ratio is greater than 1.5 and less than 2. This fractional input voltage multiplier gain prevents an “over-boosting” of the output (Figure 6).

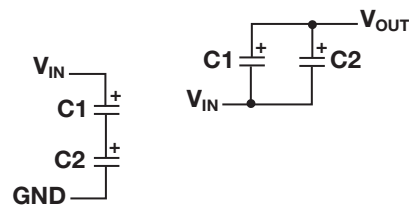
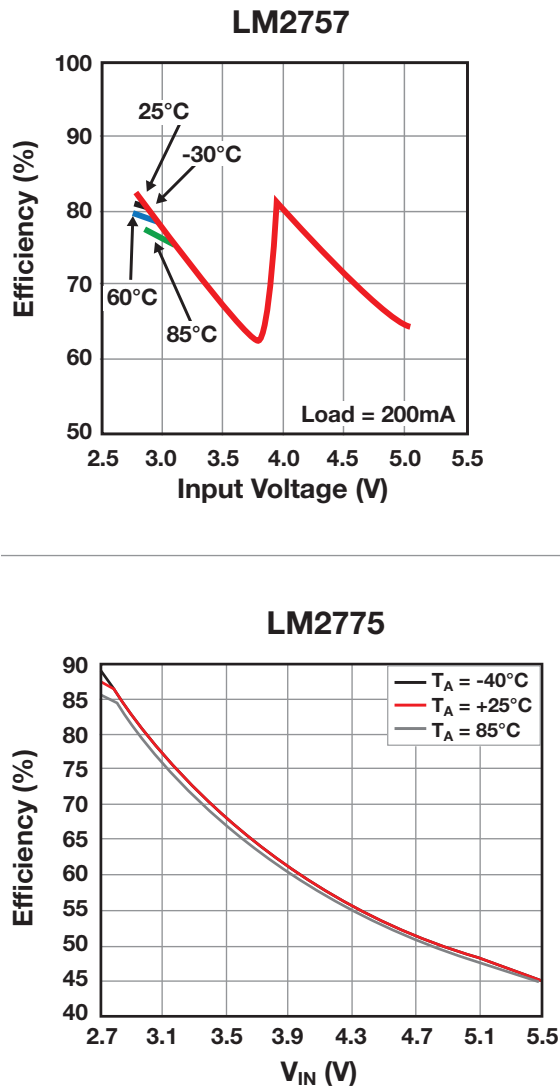

Figure 6. Example of a fractional charge pump gain that is equal to 1.5.

In **Figure 7**, the two plots highlight the efficiency gained by having the lower value gain available when operating at higher input voltages. The plot on the top uses charge pump input voltage gains of one and a half as well as a gain of two, while the plot on the bottom only has a gain of two.

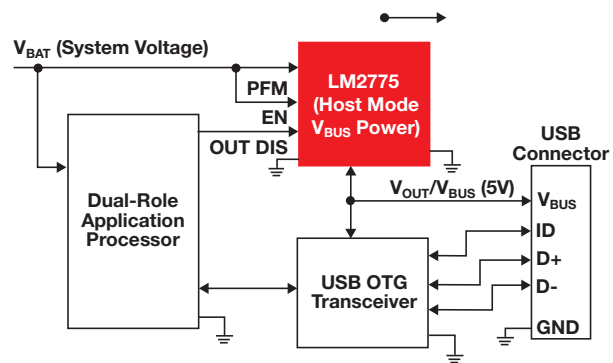

**Figure 7.** Single-gain (top) versus multi-gain efficiency (bottom).

## Boost applications

### USB OTG

In **Figure 8**, the regulated 5-V output mode on the LM2775 is often used for a universal serial bus (USB) on-the-go (OTG), or USB OTG, mobile high-definition multimedia interface (HDMI) application. You can enable/disable the device by applying a logic signal on only the EN pin, while grounding the OUTDIS pin. Depending on the application's USB/HDMI mode, you can enable the device to drive the power bus line (host) or disable it to put its output in high impedance, allowing an external supply to drive the bus line (slave). In addition to the high-impedance back-drive protection, the output current-limit protection is 250 mA (typical), which is well within USB OTG and HDMI requirements.



**Figure 8.** An example of a USB OTG topology.

### Post-regulated doubler configuration

If the targeted application requires a regulated output and an output voltage not supported by a regulated charge pump, you can use an LDO on the unregulated device's output (**Figure 9**).

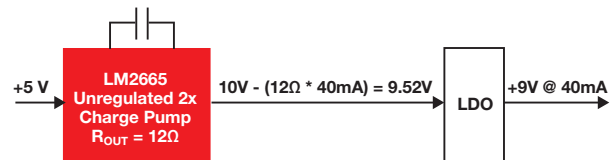

**Figure 9.** The output current of 40 mA causes a 480-mV droop on the output of the switched-capacitor voltage converter.

## Inverting charge pump

### Unregulated inverter

The second-most-common single-capacitor charge pump creates an inverse of the input voltage. In the charging phase, the switching capacitor is connected between the input voltage and ground. During the discharge phase, the positive side of the switching capacitor is tied to ground, and the negative side is connected to the output (Figure 10).

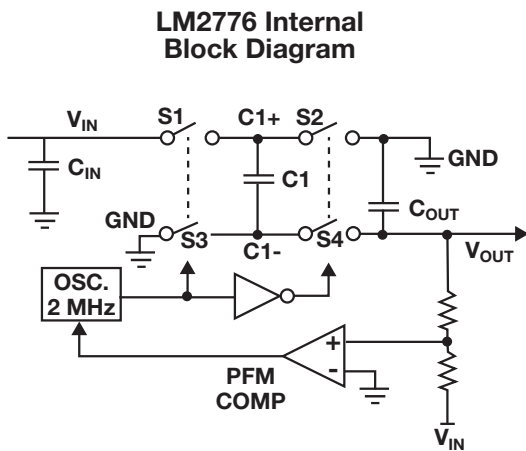

Figure 10. Inverting charge-pump inverter switch configuration.

Like an open-loop doubler, an open-loop inverter follows the same basic model for the output voltage except that the gain value is equal to negative 1. Like the doubler, you can use a negative-rail LDO to create the negative-regulated rail (Figure 11).

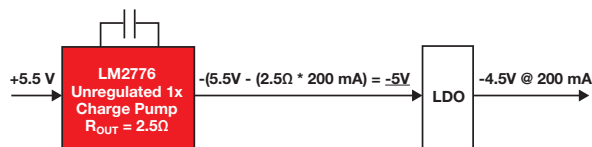

Figure 11. Adding post regulation to the unregulated inverting charge pump.

## Inverter applications

### Negative amplifier power supply

By providing a highly efficient and inverted version of the input, the unregulated converter followed by a low-noise LDO provides an ideal solution for powering the amplifier's negative supply. The key to this architecture is to take into account the voltage drops inherent to the converter and LDO. Remember that as the load current increases, the converter's output voltage decreases. To accommodate these drops, the input voltage must always be higher than the absolute value of the desired inverter output and LDO dropout requirements combined (Figure 12).

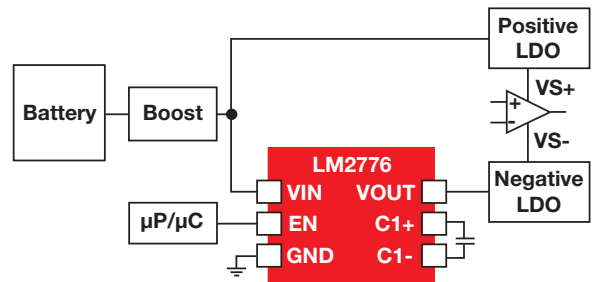

Figure 12. Amplifier bias diagram.

## Buck charge pump

### Unregulated halver

The third fundamental charge-pump converter translates the input voltage to an output voltage that is equal to a fraction of the input level. The simplest of these fractions is the half buck. This converter uses the same basic four-switch configuration as the doubling boost and the inverter. In fact, the half buck is essentially like running the doubler in reverse.

An example of a configurable device in the halver is the LM2663, even though the primary application is the unregulated doubler or inverter. By switching the doubler's input and output, the switching capacitor switches from a  $V_{IN}$  to  $V_{OUT}$  connection and then to a  $V_{OUT}$  and GND connection (Figure 13).

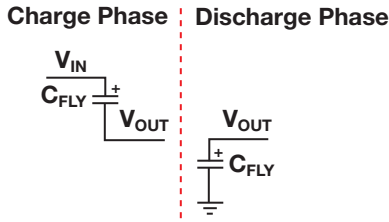

**Figure 13.** The output impedance model is the same as with an unregulated boost and inverter, except here the gain is equal to half.

### Regulated halver

In cases where you might use an LDO to regulate an output voltage, but output ripple is not otherwise a key design concern, a regulated charge-pump buck converter is a possible solution. By providing the gain conversion not realized in an LDO, the regulated buck converter can allow for higher low currents to be realized in a more efficient solution. In this type of device, regulation is either achieved through current control by way of the input-connected switches or via pulse-frequency modulation. Most devices of this nature also include a low-impedance pass-mode for instances when the input-to-output ratio approaches 1. This gain in efficiency and switch to pass-mode are highlighted in the efficiency curve regulating the output voltage at 1.5 V (**Figure 14**). The curve shows that you can realize a 30 percent efficiency gain by using a regulated charge pump (teal) instead of an LDO (red).

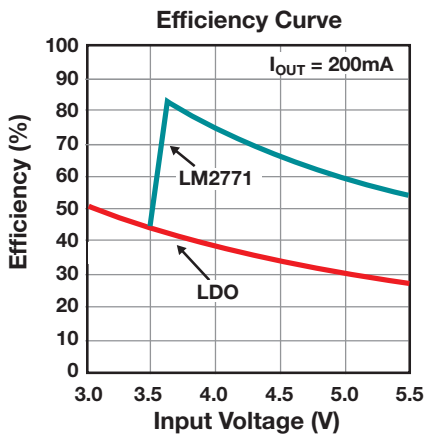

**Figure 14.** Charge-pump buck converter efficiency versus LDO efficiency.

### Multigain regulated buck

In the regulated buck halver, the multigain charge-pump converter allows for an even larger efficiency gain over the useable input range, while only adding one or two extra switching capacitors. For example, the LM2772 is a regulated 1.2-V buck converter that uses three switching capacitors to achieve buck-converter gains of one-third, two-fifths and one-half. In **Figure 15**, you can see the three different gain regions (LM2772 curve in teal. LDO in red.). From 5.5 V to near 4.6 V, the converter runs in the one-third gain; from 4.6 V to near 3.7 V, the device runs in two-fifths gain; and from 3.7 V to 3.0 V, the device runs in the one-half gain.

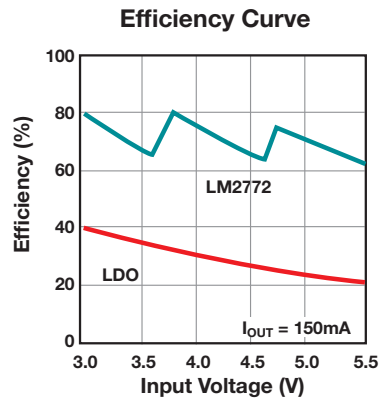

**Figure 15.** Multigain buck efficiency improvement.

## Passive-component selection and layout recommendations

### Capacitor selection

Capacitor selection for charge-pump DC/DC converters is important because capacitors are fundamental to overall solution performance.

Most charge pumps require three or four external capacitors for proper operation. Surface-mount multilayer ceramic capacitors are recommended. These capacitors are small, inexpensive and have very low  $E_{SR}$  ( $\leq 15$  m $\Omega$  typical). Tantalum capacitors, OS-CON capacitors and aluminum electrolytic capacitors generally are not recommended because of their high  $E_{SR}$  compared to ceramic capacitors. For most applications, ceramic capacitors with an X7R or X5R temperature

characteristic are recommended. These capacitors have tight capacitance tolerance (as good as  $\pm 10$  percent) and hold their value over temperature (X7R:  $\pm 15$  percent over  $-55^{\circ}\text{C}$  to  $125^{\circ}\text{C}$ ; X5R:  $\pm 15$  percent over  $-55^{\circ}\text{C}$  to  $85^{\circ}\text{C}$ ).

Capacitors with a Y5V or Z5U temperature characteristic are generally not recommended for use in charge-pump applications. These types of capacitors typically have wide capacitance tolerance (80 percent to 20 percent) and vary significantly over temperature (Y5V: 22 percent,  $-82$  percent over  $-30^{\circ}\text{C}$  to  $85^{\circ}\text{C}$  range; Z5U: 22 percent,  $-56$  percent over  $10^{\circ}\text{C}$  to  $85^{\circ}\text{C}$  range). Under some conditions, a  $1\text{-}\mu\text{F}$ -rated Y5V or Z5U capacitor could have a capacitance as low as  $0.1\ \mu\text{F}$ . Such detrimental deviation is likely to cause Y5V and Z5U capacitors to fail to meet the minimum capacitance requirements of the charge-pump.

The net capacitance of a ceramic capacitor decreases with increased DC bias. This degradation can result in lower capacitance than expected on the input and/or output, resulting in higher ripple voltages and currents. Using capacitors at DC-bias voltages significantly below the capacitor voltage rating usually minimizes DC-bias effects. It is important to consult capacitor manufacturers for information on capacitor DC-bias characteristics. Capacitance characteristics can vary quite dramatically with different application conditions, capacitor types and capacitor manufacturers. All capacitors should have a voltage rating at or above the application maximum input/output rating voltage. For switching capacitors, use a capacitor equal to the larger of the allowed input or output voltage.

## Passive-component effects on the charge-pump application

### $C_{IN}$

The input capacitor,  $C_{IN}$ , acts as charge reservoir that aids a quick transfer of charge from the supply to the switching capacitor during the charge phase of operation. The input capacitor helps keep the input voltage from drooping at the start of the charge phase when the switching capacitor is connected to the input. It also filters noise on the input pin, keeping this noise out of sensitive internal analog circuitry biased off the input line. Input capacitance has a dominant and first-order effect on input-ripple magnitude. Increasing the input-capacitance value causes a proportional decrease in input-voltage ripple.

### $C_{OUT}$

The output capacitor in the charge-pump circuit,  $C_{OUT}$ , directly impacts the magnitude of output-voltage ripple. Other prominent factors affecting output-voltage ripple include switching, output current and flying capacitance. You can make one generalization: increasing (decreasing) the output capacitance results in a proportional decrease (increase) in output-voltage ripple.

You can make a simple approximation of output ripple by calculating the amount of voltage droop that occurs when the output of the charge pump is not being driven. This occurs during the charge phase ( $\phi 1$ ). During this time, the load is driven solely by the charge on the output capacitor. The magnitude of the ripple thus follows the basic discharge equation for a capacitor ( $I = C \times dV/dt$ ), where discharge time is half the switching period, or  $0.5/FSW$ .



$$\text{RIPPLE}_{\text{Peak-Peak}} = \frac{I_{\text{OUT}}}{C_{\text{OUT}}} \times \frac{0.5}{F_{\text{SW}}} \quad (1)$$

For example, if you use the metrics of the LM2776, which has a FSW of 2 MHz and an output-capacitance recommendation of 2.2 µF, and use an output current equal to 100 mA, the approximate ripple value at the output of the charge pump would be 11 mV peak-to-peak.

### CFLY

Switching capacitors in a charge pump transfer charge from the input to the output. Flying capacitance can impact both output-current capability and ripple magnitudes. If flying capacitance is too small, the charge pump may not be able to regulate the output voltage when load currents are high. Alternatively, if the flying capacitance is too large, the switching capacitor might overwhelm the input and output capacitors, resulting in increased input and output ripple.

### Basic layout guidelines

A key advantage to a charge-pump DC/DC converter is its ease of use and design implementation compared to an inductive (magnetic) DC/DC solution. This includes the device's inherent stability and layout and component placement. Here are a few key items to pay attention to when using a charge pump in a design:

- Place capacitors as close to the charge pump as possible, preferably on the same side of the board as the device.
- Use short, wide traces to connect the external capacitors to the charge pump to minimize trace resistance and inductance.

- Use a low-resistance connection between ground and the GND pin of the charge pump. Using wide traces and/or multiple vias to connect GND to a ground plane on the board is most advantageous.

### Summary

There are instances where a charge pump provides an alternative option with inherent advantages over an inductive converter or an LDO. Compared with a magnetic DC/DC converter, the PCB area occupied by a converter solution is often smaller and thinner using the charge-pump converter and a small number of thin and inexpensive capacitors when the inductor is eliminated. In fixed-rail input cases, the single-gain converter can achieve efficiencies which approach that of an inductive converter. For moving input-voltage applications like those requiring a battery power supply, you can use a multigain converter to maintain a respectable efficiency level over the operating range. It is worth considering a charge-pump DC/DC converter in a design for low-power boost, inverter or buck applications given its small PCB footprint, ease of design and cost-effectiveness with reasonable conversion efficiency.

### References

- Product datasheets: [LM2775](#), [LM2757](#), [LM2663](#), [LM2665](#), [LM8850](#), [LM2776](#), [LM2771](#), [LM2772](#)
- [Charge Pump](#) parametric selection table

**Important Notice:** The products and services of Texas Instruments Incorporated and its subsidiaries described herein are sold subject to TI's standard terms and conditions of sale. Customers are advised to obtain the most current and complete information about TI products and services before placing orders. TI assumes no liability for applications assistance, customer's applications or product designs, software performance, or infringement of patents. The publication of information regarding any other company's products or services does not constitute TI's approval, warranty or endorsement thereof.

## IMPORTANT NOTICE

Texas Instruments Incorporated and its subsidiaries (TI) reserve the right to make corrections, enhancements, improvements and other changes to its semiconductor products and services per JESD46, latest issue, and to discontinue any product or service per JESD48, latest issue. Buyers should obtain the latest relevant information before placing orders and should verify that such information is current and complete. All semiconductor products (also referred to herein as "components") are sold subject to TI's terms and conditions of sale supplied at the time of order acknowledgment.

TI warrants performance of its components to the specifications applicable at the time of sale, in accordance with the warranty in TI's terms and conditions of sale of semiconductor products. Testing and other quality control techniques are used to the extent TI deems necessary to support this warranty. Except where mandated by applicable law, testing of all parameters of each component is not necessarily performed.

TI assumes no liability for applications assistance or the design of Buyers' products. Buyers are responsible for their products and applications using TI components. To minimize the risks associated with Buyers' products and applications, Buyers should provide adequate design and operating safeguards.

TI does not warrant or represent that any license, either express or implied, is granted under any patent right, copyright, mask work right, or other intellectual property right relating to any combination, machine, or process in which TI components or services are used. Information published by TI regarding third-party products or services does not constitute a license to use such products or services or a warranty or endorsement thereof. Use of such information may require a license from a third party under the patents or other intellectual property of the third party, or a license from TI under the patents or other intellectual property of TI.

Reproduction of significant portions of TI information in TI data books or data sheets is permissible only if reproduction is without alteration and is accompanied by all associated warranties, conditions, limitations, and notices. TI is not responsible or liable for such altered documentation. Information of third parties may be subject to additional restrictions.

Resale of TI components or services with statements different from or beyond the parameters stated by TI for that component or service voids all express and any implied warranties for the associated TI component or service and is an unfair and deceptive business practice. TI is not responsible or liable for any such statements.

Buyer acknowledges and agrees that it is solely responsible for compliance with all legal, regulatory and safety-related requirements concerning its products, and any use of TI components in its applications, notwithstanding any applications-related information or support that may be provided by TI. Buyer represents and agrees that it has all the necessary expertise to create and implement safeguards which anticipate dangerous consequences of failures, monitor failures and their consequences, lessen the likelihood of failures that might cause harm and take appropriate remedial actions. Buyer will fully indemnify TI and its representatives against any damages arising out of the use of any TI components in safety-critical applications.

In some cases, TI components may be promoted specifically to facilitate safety-related applications. With such components, TI's goal is to help enable customers to design and create their own end-product solutions that meet applicable functional safety standards and requirements. Nonetheless, such components are subject to these terms.

No TI components are authorized for use in FDA Class III (or similar life-critical medical equipment) unless authorized officers of the parties have executed a special agreement specifically governing such use.

Only those TI components which TI has specifically designated as military grade or "enhanced plastic" are designed and intended for use in military/aerospace applications or environments. Buyer acknowledges and agrees that any military or aerospace use of TI components which have **not** been so designated is solely at the Buyer's risk, and that Buyer is solely responsible for compliance with all legal and regulatory requirements in connection with such use.

TI has specifically designated certain components as meeting ISO/TS16949 requirements, mainly for automotive use. In any case of use of non-designated products, TI will not be responsible for any failure to meet ISO/TS16949.

### Products

Audio	<a href="http://www.ti.com/audio">www.ti.com/audio</a>
Amplifiers	<a href="http://amplifier.ti.com">amplifier.ti.com</a>
Data Converters	<a href="http://dataconverter.ti.com">dataconverter.ti.com</a>
DLP® Products	<a href="http://www.dlp.com">www.dlp.com</a>
DSP	<a href="http://dsp.ti.com">dsp.ti.com</a>
Clocks and Timers	<a href="http://www.ti.com/clocks">www.ti.com/clocks</a>
Interface	<a href="http://interface.ti.com">interface.ti.com</a>
Logic	<a href="http://logic.ti.com">logic.ti.com</a>
Power Mgmt	<a href="http://power.ti.com">power.ti.com</a>
Microcontrollers	<a href="http://microcontroller.ti.com">microcontroller.ti.com</a>
RFID	<a href="http://www.ti-rfid.com">www.ti-rfid.com</a>
OMAP Applications Processors	<a href="http://www.ti.com/omap">www.ti.com/omap</a>
Wireless Connectivity	<a href="http://www.ti.com/wirelessconnectivity">www.ti.com/wirelessconnectivity</a>

### Applications

Automotive and Transportation	<a href="http://www.ti.com/automotive">www.ti.com/automotive</a>
Communications and Telecom	<a href="http://www.ti.com/communications">www.ti.com/communications</a>
Computers and Peripherals	<a href="http://www.ti.com/computers">www.ti.com/computers</a>
Consumer Electronics	<a href="http://www.ti.com/consumer-apps">www.ti.com/consumer-apps</a>
Energy and Lighting	<a href="http://www.ti.com/energy">www.ti.com/energy</a>
Industrial	<a href="http://www.ti.com/industrial">www.ti.com/industrial</a>
Medical	<a href="http://www.ti.com/medical">www.ti.com/medical</a>
Security	<a href="http://www.ti.com/security">www.ti.com/security</a>
Space, Avionics and Defense	<a href="http://www.ti.com/space-avionics-defense">www.ti.com/space-avionics-defense</a>
Video and Imaging	<a href="http://www.ti.com/video">www.ti.com/video</a>

### TI E2E Community

[e2e.ti.com](http://e2e.ti.com)