

LM3489x Hysteretic PFET Buck Controller With Enable Pin

1 Features

- Qualified for Automotive Parts
- AEC-Q100 Qualified With the Following Results:
 - Device Temperature Grade 1: -40°C to 125°C Ambient Operating Temperature Range
 - Device HBM ESD Classification Level 2
 - Device CDM ESD Classification Level C5
- Easy-to-Use Control Methodology
- No Control Loop Compensation Required
- Wide 4.5-V to 35-V Input Range
- 1.239 V to V_{IN} Adjustable Output Range
- High Efficiency: 93%
- $\pm 1.3\%$ ($\pm 2\%$ Over Temperature) Internal Reference
- 100% Duty Cycle Operation
- Maximum Operation Frequency > 1 MHz
- Current Limit Protection
- Dedicated Enable Pin (on if Unconnected)
- Shutdown Mode Draws Only 7- μA Supply Current
- 8-Pin VSSOP Package

2 Applications

- Set-Top Boxes
- DSL or Cable Modems
- PC/IA
- Auto PCs
- TFT Monitors
- Battery-Powered Portable Applications
- Distributed Power Systems
- Always-On Power
- High-Power LED Drivers
- Automotive

3 Description

The LM3489 device is a high-efficiency PFET switching regulator controller that can be used to quickly and easily develop a small, cost-effective, switching buck regulator for a wide range of applications. The hysteretic control architecture provides for simple design without any control loop stability concerns using a wide variety of external components. The PFET architecture also allows for low component count as well as ultra-low dropout, 100% duty cycle operation. Another benefit is high efficiency operation at light loads without an increase in output ripple. A dedicated enable pin provides a shutdown mode drawing only 7 μA . Leaving the enable pin unconnected defaults to on.

Current limit protection can be implemented by measuring the voltage across the PFET's $R_{\text{DS(ON)}}$, thus eliminating the need for a sense resistor. A sense resistor may be used to improve current limit accuracy if desired. The cycle-by-cycle current limit can be adjusted with a single resistor, ensuring safe operation over a range of output currents.

Device Information⁽¹⁾

PART NUMBER	PACKAGE	BODY SIZE (NOM)
LM3489	VSSOP (8)	3.00 mm x 3.00 mm
LM3489-Q1		

(1) For all available packages, see the orderable addendum at the end of the data sheet.

Typical Application Circuit

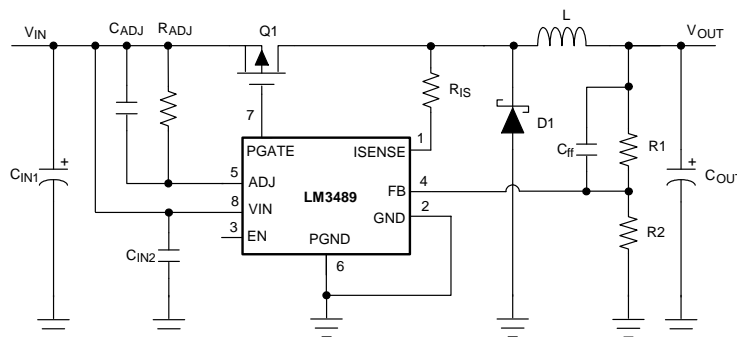

Copyright © 2016, Texas Instruments Incorporated



Table of Contents

1 Features	1	7.4 Device Functional Mode	14
2 Applications	1	8 Application and Implementation	15
3 Description	1	8.1 Application Information.....	15
4 Revision History	2	8.2 Typical Application	15
5 Pin Configuration and Functions	3	9 Power Supply Recommendations	19
6 Specifications	4	10 Layout	19
6.1 Absolute Maximum Ratings	4	10.1 Layout Guidelines	19
6.2 ESD Ratings: LM3489	4	10.2 Layout Examples.....	19
6.3 ESD Ratings: LM3489-Q1	4	11 Device and Documentation Support	20
6.4 Recommended Operating Conditions	4	11.1 Related Links	20
6.5 Thermal Information	5	11.2 Receiving Notification of Documentation Updates	20
6.6 Electrical Characteristics.....	5	11.3 Community Resources.....	20
6.7 Typical Characteristics	6	11.4 Trademarks	20
7 Detailed Description	9	11.5 Electrostatic Discharge Caution.....	20
7.1 Overview	9	11.6 Glossary	20
7.2 Functional Block Diagram	9	12 Mechanical, Packaging, and Orderable	20
7.3 Feature Description.....	9	Information	20

4 Revision History

NOTE: Page numbers for previous revisions may differ from page numbers in the current version.

Changes from Revision B (February 2013) to Revision C	Page
• Added <i>ESD Ratings</i> table, <i>Feature Description</i> section, <i>Device Functional Modes</i> , <i>Application and Implementation</i> section, <i>Power Supply Recommendations</i> section, <i>Layout</i> section, <i>Device and Documentation Support</i> section, and <i>Mechanical, Packaging, and Orderable Information</i> section	1
• Added AEC-Q100 Qualification bullets to <i>Features</i>	1
• Deleted Lead temperature (Vapor phase and Infrared maximums)	4
• Added <i>Thermal Information</i> table	5

Changes from Revision A (February 2013) to Revision B	Page
• Changed layout of National Semiconductor Data Sheet to TI format	1

5 Pin Configuration and Functions

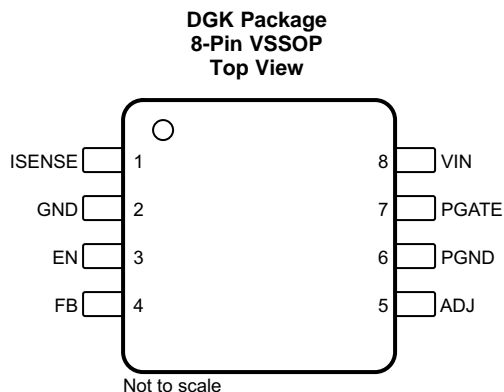

Pin Functions

PIN		I/O	DESCRIPTION
NO.	NAME		
1	ISENSE	I	The current sense input pin. This pin must be connected to the PFET drain terminal directly or through a series resistor up to 600 Ω for 28 V > VIN > 35 V.
2	GND	—	Signal ground
3	EN	I	Enable pin. Connect EN pin to ground to shutdown the part or float to enable operation (Internally pulled high). This pin can also be used to perform UVLO function.
4	FB	I	The feedback input. Connect the FB to a resistor voltage divider between the output and GND for an adjustable output voltage.
5	ADJ	I	Current limit threshold adjustment. Connected to an internal 5.5- μ A current source. A resistor is connected between this pin and VIN. The voltage across this resistor is compared with the ISENSE pin voltage to determine if an overcurrent condition has occurred.
6	PGND	—	Power ground
7	PGATE	O	Gate drive output for the external PFET. PGATE swings between VIN and VIN 5-V.
8	VIN	I	Power supply input pin

6 Specifications

6.1 Absolute Maximum Ratings

 See ⁽¹⁾.

	MIN	MAX	UNIT
V _{IN} voltage	−0.3	36	V
PGATE voltage	−0.3	36	V
FB voltage	−0.3	5	V
ISENSE voltage	−1	36	V
	−1 (<100 ns)		
ADJ voltage	−0.3	36	V
EN voltage ⁽²⁾	−0.3	6	V
Power dissipation, T _A = 25°C ⁽³⁾		417	mW
Junction temperature, T _J	−40	150	°C
Storage temperature, T _{stg}	−65	150	°C

- Stresses beyond those listed under *Absolute Maximum Ratings* may cause permanent damage to the device. These are stress ratings only, which do not imply functional operation of the device at these or any other conditions beyond those indicated under *Recommended Operating Conditions*. Exposure to absolute-maximum-rated conditions for extended periods may affect device reliability.
- This pin is internally pulled high and clamped at 8 V (typical). The absolute maximum and operating maximum rating specifies the input level allowed for an external voltage source applied to this pin without triggering the internal clamp with margin.
- The maximum allowable power dissipation is a function of the maximum junction temperature, T_{J,MAX}, the junction-to-ambient thermal resistance, R_{θJA} and the ambient temperature, T_A. The maximum allowable power dissipation at any ambient temperature is calculated using: P_D = (T_J − T_A) / R_{θJA}. Exceeding the maximum allowable power dissipation will lead to excessive die temperature.

6.2 ESD Ratings: LM3489

		VALUE	UNIT
V _(ESD) Electrostatic discharge	Human-body model (HBM), per ANSI/ESDA/JEDEC JS-001 ⁽¹⁾	±2000	V
	Charged-device model (CDM), per JEDEC specification JESD22-C101 ⁽²⁾	±750	

- JEDEC document JEP155 states that 500-V HBM allows safe manufacturing with a standard ESD control process.
- JEDEC document JEP157 states that 250-V CDM allows safe manufacturing with a standard ESD control process.

6.3 ESD Ratings: LM3489-Q1

		VALUE	UNIT
V _(ESD) Electrostatic discharge	Human body model (HBM), per AEC Q100-002 ⁽¹⁾	±2000	V
	Charged device model (CDM), per AEC Q100-011	±750	

- JEDEC document JEP155 states that 500-V HBM allows safe manufacturing with a standard ESD control process.

6.4 Recommended Operating Conditions

over operating free-air temperature range (unless otherwise noted)

		MIN	MAX	UNIT
V _{IN} Supply voltage		4.5	35	V
	EN voltage ⁽¹⁾		5.5	
T _J Operating junction temperature ⁽²⁾	LM3489	−40	125	°C
	LM3489-Q1	−40	150	°C

- This pin is internally pulled high and clamped at 8 V (typical). The absolute maximum and operating maximum rating specifies the input level allowed for an external voltage source applied to this pin without triggering the internal clamp with margin.
- High junction temperatures degrade operating lifetimes. Operating lifetime is de-rated for junction temperatures greater than 125°C.

6.5 Thermal Information

THERMAL METRIC ⁽¹⁾		LM3489	UNIT
		DGK (VSSOP)	
		8 PINS	
R _{θJA}	Junction-to-ambient thermal resistance	163.7	°C/W
R _{θJC(top)}	Junction-to-case (top) thermal resistance	56.6	°C/W
R _{θJB}	Junction-to-board thermal resistance	83.3	°C/W
ψ _{JT}	Junction-to-top characterization parameter	5.4	°C/W
ψ _{JB}	Junction-to-board characterization parameter	82	°C/W
R _{θJC(bot)}	Junction-to-case (bottom) thermal resistance	—	°C/W

(1) For more information about traditional and new thermal metrics, see the [Semiconductor and IC Package Thermal Metrics](#) application report.

6.6 Electrical Characteristics

Typical values correspond to T_J = 25°C. Minimum and maximum limits apply over T_J = –40°C to 125°C for the LM3489 and LM3489-Q1. V_{IN} = 12 V, V_{ISNS} = V_{IN} – 1 V, and V_{ADJ} = V_{IN} – 1.1 V (unless otherwise noted).

PARAMETER		TEST CONDITIONS	MIN	TYP	MAX	UNIT
I _{SHDN}	Shutdown input supply current	EN = 0 V		7	15	μA
V _{EN}	Enable threshold voltage	Enable rising	1.15	1.5	1.85	V
V _{EN_HYST}	Enable threshold hysteresis			130		mV
I _Q	Quiescent current at ground pin	FB = 1.5 V (not switching)		280	400	μA
V _{FB}	Feedback voltage ⁽¹⁾		1.214	1.239	1.264	V
V _{HYST}	Comparator hysteresis			10	20	mV
V _{CL_OFFSET}	Current limit comparator offset	V _{FB} = 1 V	–20	0	20	mV
I _{CL_ADJ}	Current limit ADJ current source	V _{FB} = 1.5 V	3	5.5	7	μA
T _{CL}	Current limit one-shot off-time	V _{ADJ} = 11.5 V, V _{ISNS} = 11 V, V _{FB} = 1 V	6	9	14	μs
R _{PGATE}	Driver resistance	Source, I _{SOURCE} = 100 mA		5.5		Ω
		Sink, I _{SINK} = 100 mA		8.5		
I _{PGATE}	Driver output current	Source, V _{IN} = 7 V, PGATE = 3.5 V		0.44		A
		Sink, V _{IN} = 7 V, PGATE = 3.5 V		0.1		
I _{FB}	FB pin bias current ⁽²⁾	V _{FB} = 1 V		300	750	nA
T _{ONMIN_NOR}	Minimum ON time in normal operation	V _{ISNS} = V _{ADJ} + 0.1 V, C _{load} on OUT = 1000 pF ⁽³⁾		100		ns
T _{ONMIN_CL}	Minimum ON time in current limit	V _{ISNS} = V _{ADJ} – 0.1 V, V _{FB} = 1 V, C _{load} on OUT = 1000 pF ⁽³⁾		200		ns
%V _{FB} /ΔV _{IN}	Feedback voltage line regulation	4.5 V ≤ V _{IN} ≤ 35 V		0.01%		V

(1) The V_{FB} is the trip voltage at the FB pin when PGATE switches from high to low.

(2) Bias current flows out from the FB pin.

(3) A 1000-pF capacitor is connected between V_{IN} and PGATE.

6.7 Typical Characteristics

At $T_A = 25^\circ\text{C}$ and applicable to both LM3489 and LM3489-Q1 at $V_{IN} = 12\text{ V}$ with configuration in [Detailed Description](#) (unless otherwise noted).

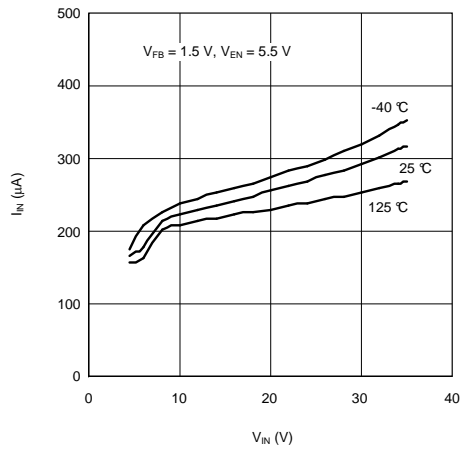

Figure 1. Quiescent Current vs Input Voltage

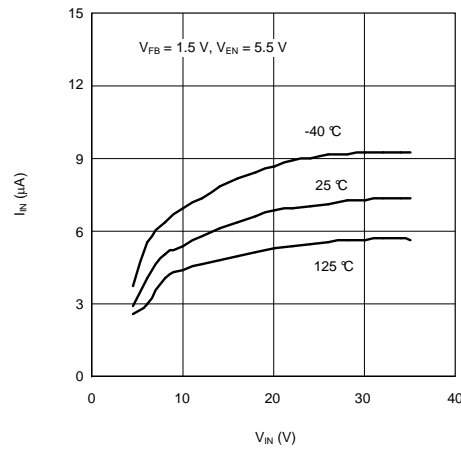

Figure 2. Shutdown Current vs Input Voltage

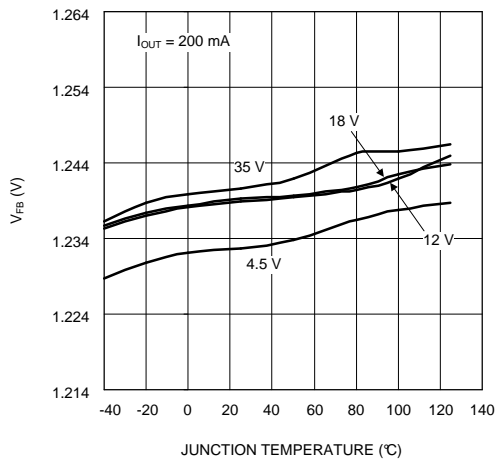

Figure 3. Feedback Voltage vs Temperature

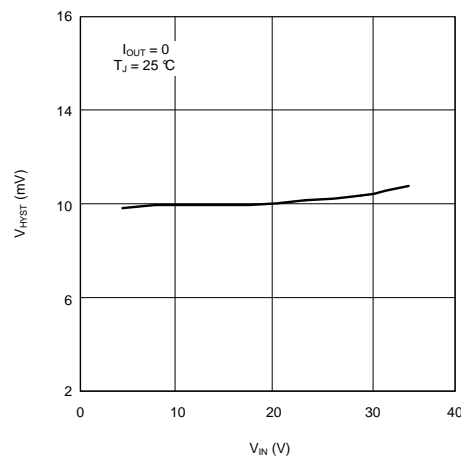

Figure 4. Feedback Voltage Hysteresis vs Input Voltage

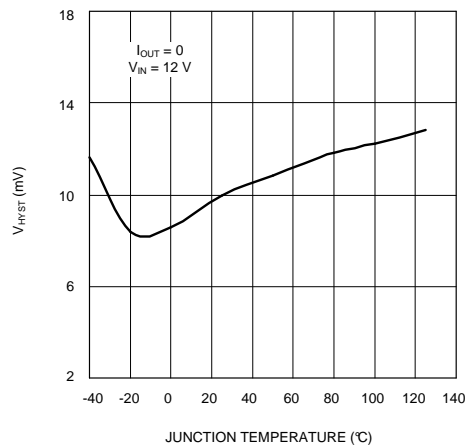

Figure 5. Feedback Voltage Hysteresis vs Temperature

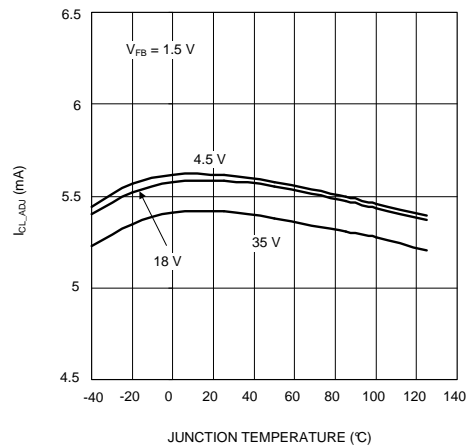

Figure 6. Current Limit ADJ Current vs Temperature

Typical Characteristics (continued)

At $T_A = 25^\circ\text{C}$ and applicable to both LM3489 and LM3489-Q1 at $V_{IN} = 12\text{ V}$ with configuration in *Detailed Description* (unless otherwise noted).

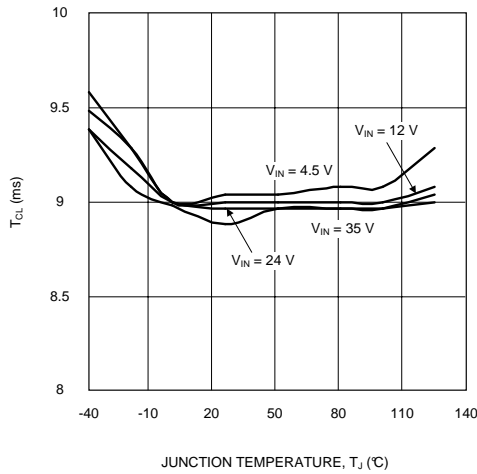

Figure 7. Current Limit One Shot OFF Time vs Temperature

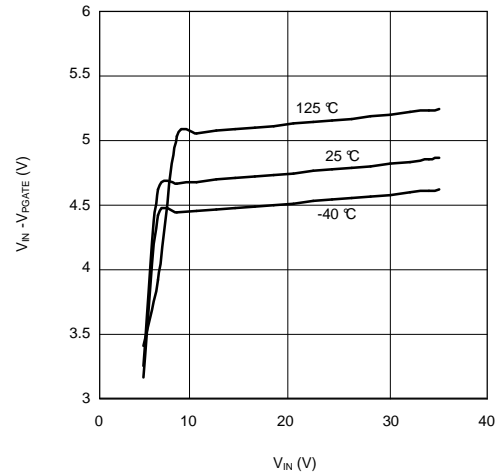

Figure 8. $V_{IN} - V_{GATE}$ vs V_{IN}

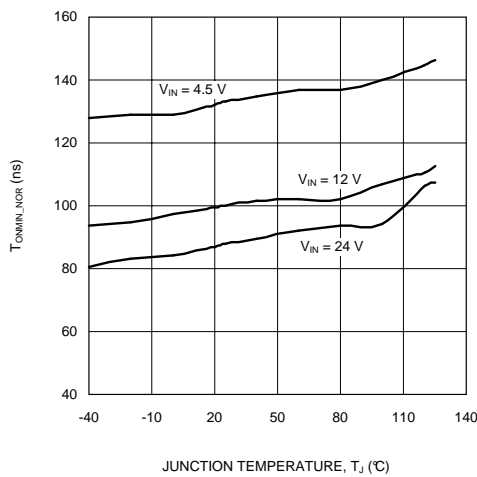

Figure 9. Minimum ON Time vs Temperature (Normal Operation)

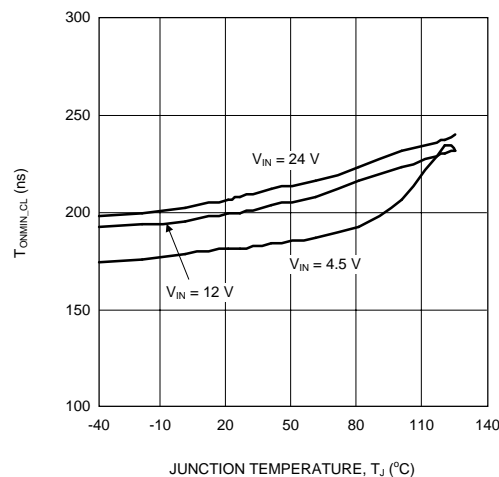

Figure 10. Minimum ON Time vs Temperature (Current Limit)

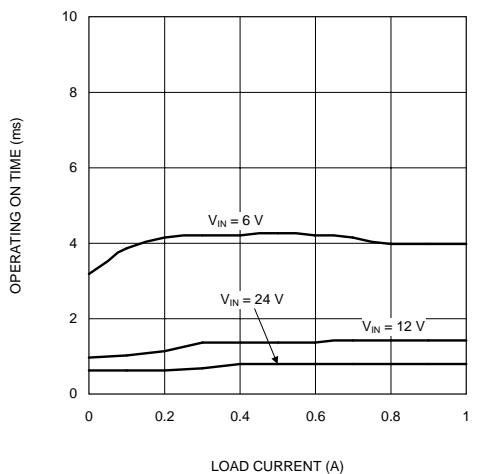

Figure 11. Operating ON Time vs Load Current

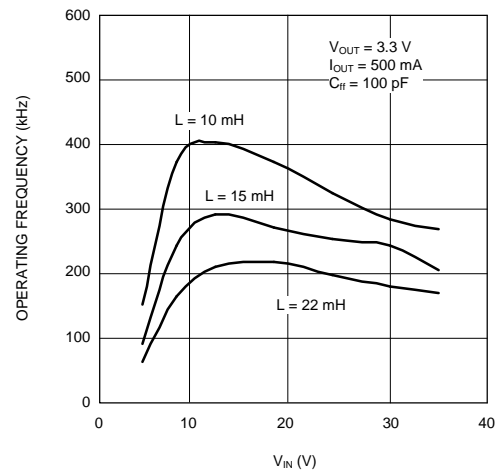
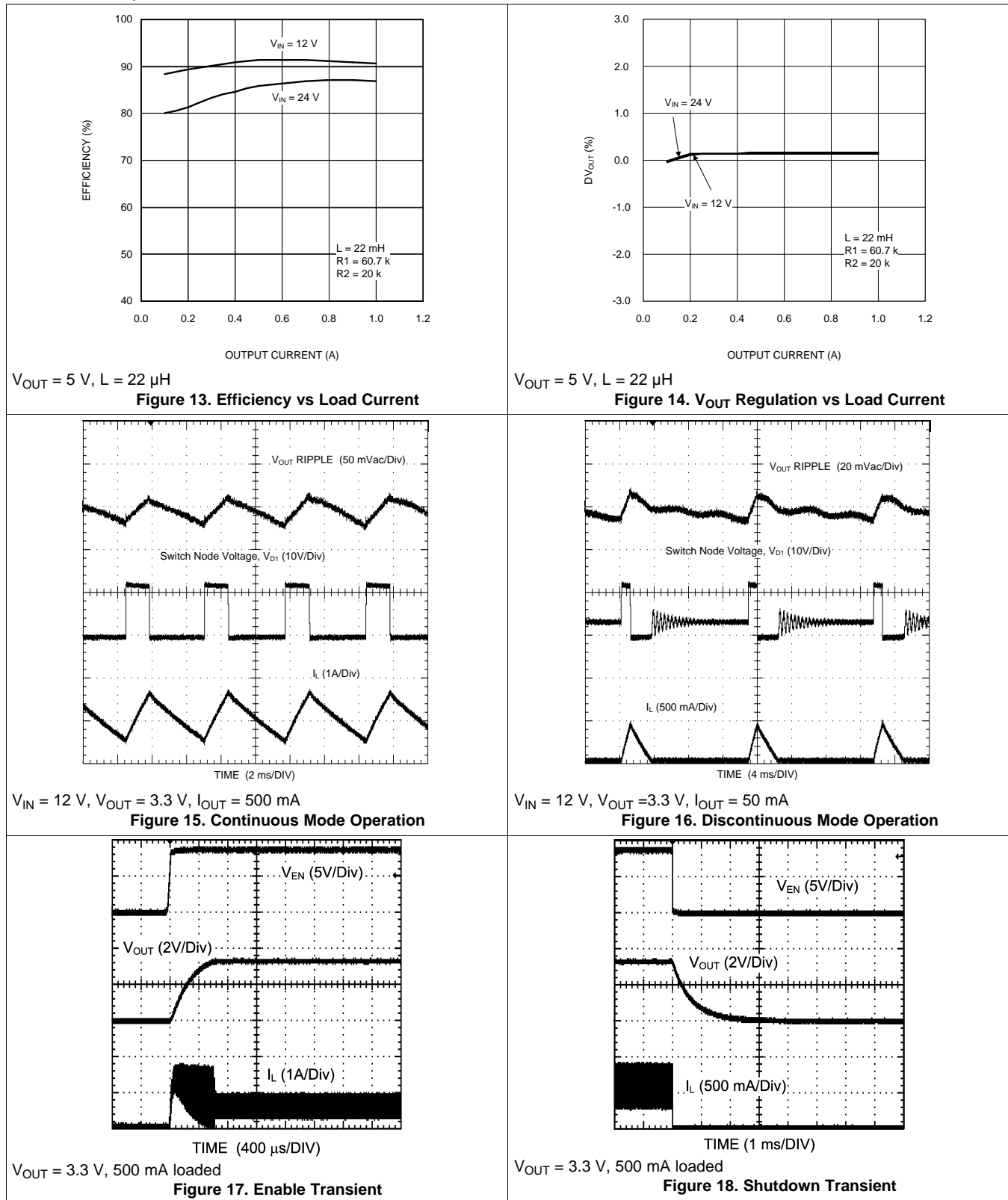

Figure 12. Operating Frequency vs Input Voltage

Typical Characteristics (continued)

At $T_A = 25^\circ\text{C}$ and applicable to both LM3489 and LM3489-Q1 at $V_{IN} = 12\text{ V}$ with configuration in *Detailed Description* (unless otherwise noted).



7 Detailed Description

7.1 Overview

The LM3489 is a buck (step-down) DC-DC controller that uses a hysteretic control scheme. The control comparator is designed with approximately 10 mV of hysteresis. In response to the voltage at the FB pin, the gate drive (PGATE pin) turns the external PFET on or off. When the inductor current is too high, the current limit protection circuit engages and turns the PFET off for approximately 9 μ s.

Hysteretic control does not require an internal oscillator. Switching frequency depends on the external components and operating conditions. The operating frequency reduces at light loads resulting in excellent efficiency compared to other architectures.

The output voltage can be programmed by two external resistors. The output can be set in a wide range from 1.239 V (typical) to V_{IN} .

7.2 Functional Block Diagram

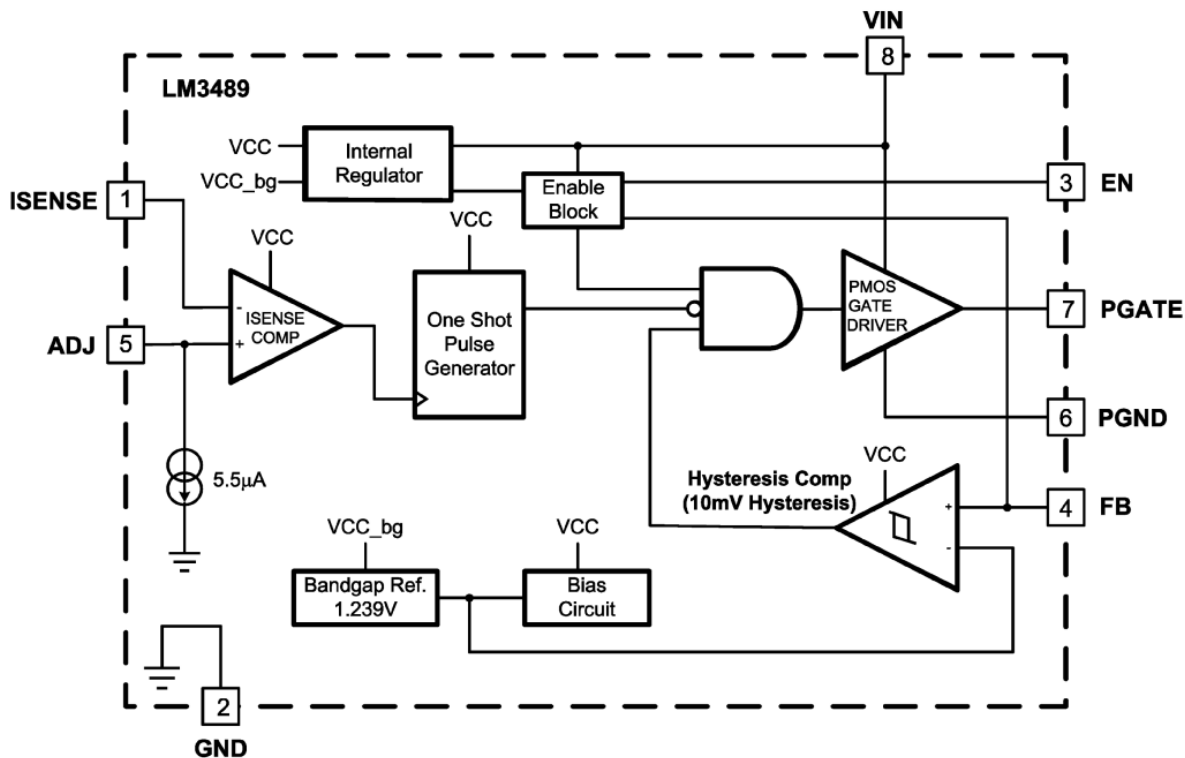

Copyright © 2016, Texas Instruments Incorporated

7.3 Feature Description

7.3.1 Hysteretic Control Circuit

When the FB input to the control comparator falls below the reference voltage (1.239 V), the output of the comparator switches to a low state. This results in the driver output, PGATE, pulling the gate of the PFET low and turning on the PFET. With the PFET on, the input supply charges C_{OUT} and supplies current to the load through the series path through the PFET and the inductor. Current through the inductor ramps up linearly and the output voltage increases. As the FB voltage reaches the upper threshold, which is the internal reference voltage plus 10 mV, the output of the comparator changes from low to high, and the PGATE responds by turning the PFET off. As the PFET turns off, the inductor voltage reverses, the catch diode turns on, and the current through the inductor ramps down. Then, as the output voltage reaches the internal reference voltage again, the next cycle starts.

Feature Description (continued)

The LM3489 operates in discontinuous conduction mode at light-load current or continuous conduction mode at heavy-load current. In discontinuous conduction mode, current through the inductor starts at zero and ramps up to the peak then ramps down to zero. The next cycle starts when the FB voltage reaches the reference voltage. Until then, the inductor current remains zero and the output capacitor supplies the load. The operating frequency is lower and switching losses reduced. In continuous conduction mode, current always flows through the inductor and never ramps down to zero.

The output voltage (V_{OUT}) can be programmed by 2 external resistors. It can be calculated with [Equation 1](#).

$$V_{OUT} = 1.239 \times (R1 + R2) / R2 \quad (1)$$

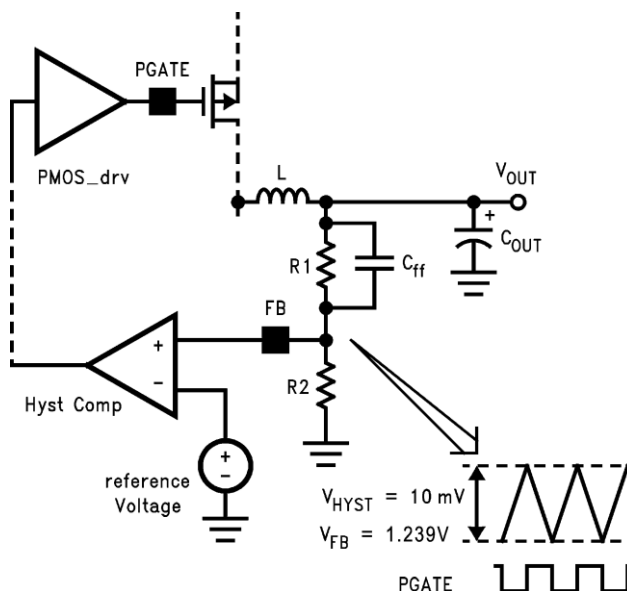

Figure 19. Hysteretic Window

The minimum output voltage ripple (V_{OUT_PP}) can be calculated in the same way with [Equation 2](#).

$$V_{OUT_PP} = V_{HYST} (R1 + R2) / R2 \quad (2)$$

For example, with V_{OUT} set to 3.3 V, V_{OUT_PP} is 26.6 mV in [Equation 3](#).

$$V_{OUT_PP} = 0.01 \times (33k + 20k) / 20k = 0.0266 \text{ V} \quad (3)$$

Operating frequency (F) is determined by knowing the input voltage, output voltage, inductor, V_{HYST} , ESR (Equivalent Series Resistance) of output capacitor, and the delay. It can be approximately calculated using [Equation 4](#).

$$F = \frac{V_{OUT}}{V_{IN}} \times \frac{(V_{IN} - V_{OUT}) \times ESR}{(V_{HYST} \times \alpha \times L) + (V_{IN} \times \text{delay} \times ESR)}$$

where

- $\alpha: (R1 + R2) / R2$ (4)

7.3.1.1 Delay

It includes the LM3489 propagation delay time and the PFET delay time. The propagation delay is 90 ns typically (see [Figure 20](#)).

Feature Description (continued)

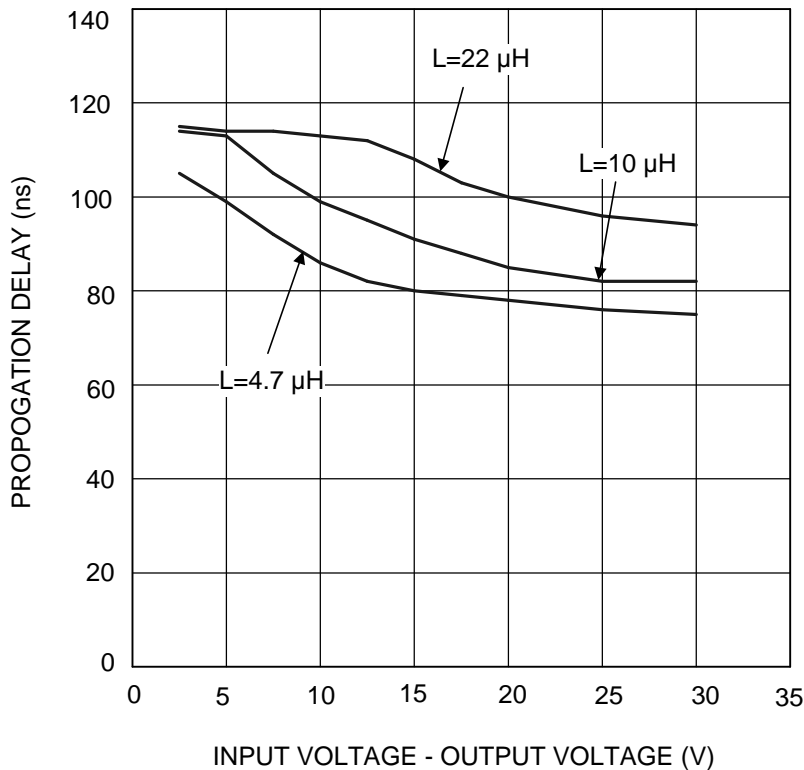

Figure 20. Propagation Delay

The operating frequency and output ripple voltage can also be significantly influenced by the speed up capacitor (Cff). Cff is connected in parallel with the high side feedback resistor, R1. The location of this capacitor is similar to where a phase lead capacitor would be located in a PWM control scheme. However its effect on hysteretic operation is much different. Cff effectively shorts out R1 at the switching frequency and applies the full output ripple to the FB pin without dividing by the R2/R1 ratio. The end result is a reduction in output ripple and an increase in operating frequency. When adding Cff, calculate the formula above with $\alpha = 1$. The value of Cff depend on the desired operating frequency and the value of R2. A good starting point is 470-pF ceramic at 100-kHz decreasing linearly with increased operating frequency. Also note that as the output voltage is programmed below 2.5 V, the effect of Cff will decrease significantly.

7.3.2 Current Limit Operation

The LM3489 has a cycle-by-cycle current limit. Current limit is sensed across the V_{DS} of the PFET or across an additional sense resistor. When current limit is activated, the LM3489 turns off the external PFET for a period of 9 μ s (typical). The current limit is adjusted by an external resistor, R_{ADJ} .

The current limit circuit is composed of the ISENSE comparator and the one-shot pulse generator. The positive input of the ISENSE comparator is the ADJ pin. An internal 5.5- μ A current sink creates a voltage across the external R_{ADJ} resistor. This voltage is compared to the voltage across the PFET or sense resistor. The ADJ voltage can be calculated with [Equation 5](#).

$$V_{ADJ} = V_{IN} - (R_{ADJ} \times 3 \mu A)$$

where

- 3 μ A is the minimum I_{CL-ADJ} value (5)

The negative input of the ISENSE comparator is the ISENSE pin that must be connected to the drain of the external PFET. The inductor current is determined by sensing the V_{DS} . It can be calculated with [Equation 6](#).

$$V_{ISENSE} = V_{IN} - (R_{DS(on)} \times I_{IND_PEAK}) = V_{IN} - V_{DS} \quad (6)$$

Feature Description (continued)

At high input voltages (> 28 V) increased undershoot at the switch node can cause an increase in the current limit threshold. To avoid this problem, a low V_f Schottky catch diode must be used (see [Catch Diode Selection \(D1\)](#)). Additionally, a resistor can be placed between the ISENSE pin and the switch node. Any value in the range of 220 Ω to 600 Ω is recommended.

7.3.3 Start Up

The current limit circuit is active during start-up. During start-up, the PFET stays on until either the current limit or the feedback comparator is tripped

If the current limit comparator is tripped first, then take the the foldback characteristic into account. Start-up into full load may require a higher current limit set point or the load must be applied after start-up.

One problem with selecting a higher current limit is inrush current during start-up. Increasing the capacitance (C_{ADJ}) in parallel with R_{ADJ} results in a soft-start characteristic. C_{ADJ} and R_{ADJ} create an RC time constant forcing current limit to activate at a lower current. The output voltage will ramp more slowly when using this technique. There is example start-up plot for C_{ADJ} equal to 1 nF in [Typical Characteristics](#). Lower values for C_{ADJ} will have little to no effect on soft-start.

7.3.4 External Sense Resistor

The V_{DS} of a PFET tends to vary significantly over temperature. This will result an equivalent variation in current limit. To improve current limit accuracy, an external sense resistor can be connected from V_{IN} to the source of the PFET, as shown in [Figure 23](#). The current sense resistor, R_{CS} must have value comparable with R_{DSON} of the PFET used, typically in the range of 50 m Ω to 200 m Ω . [Equation 6](#) in [Current Limit Operation](#) can be used by replacing the R_{DSON} with R_{CS} .

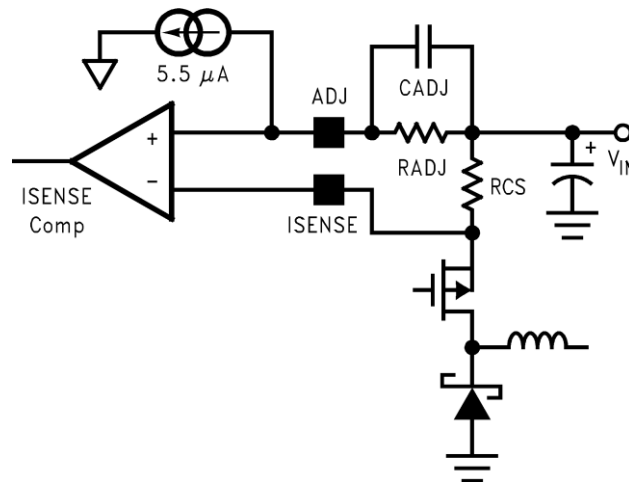

Figure 23. Current Sensing by External Resistor

7.3.5 PGATE

When switching, the PGATE pin swings from V_{IN} (off) to some voltage below V_{IN} (on). How far the PGATE will swing depends on several factors including the capacitance, on-time, and input voltage.

PGATE voltage swing will increase with decreasing gate capacitance. Although PGATE voltage will typically be around $V_{IN}-5V$, with very small gate capacitances, this value can increase to a typical maximum of $V_{IN}-8.3 V$.

Additionally, PGATE swing voltage will increase as on-time increases. During long on-times, such as when operating at 100% duty cycle, the PGATE voltage will eventually fall to its maximum voltage of $V_{IN}-8.3 V$ (typical) regardless of the PFET gate capacitance.

The PGATE voltage will not fall below 0.4 V (typical). Therefore, when the input voltage falls below approximately 9 V, the PGATE swing voltage range is reduced. At an input voltage of 7 V, for instance, PGATE will swing from 7 V to a minimum of 0.4 V.

Feature Description (continued)

7.3.6 Adjustable UVLO

The undervoltage lockout (UVLO) function can be implemented as shown in Figure 24. By incorporating the feature of the internal enable threshold, the lockout level can be programmed through an external potential divider formed with R3 and R4. The input voltage information is detected and compared with the enable threshold and the device operation is inhibited when V_{IN} drops below the preset UVLO level. The UVLO and hysteresis voltage can be calculated with Equation 7 and Equation 8.

$$V_{IN(UVLO)} = V_{EN} \left(1 + \frac{R4}{R3} \right) \quad (7)$$

$$V_{IN(UVLO_HYST)} = V_{EN_HYST} \times \left(1 + \frac{R4}{R3} \right)$$

where

- V_{EN} is the enable rising threshold voltage
 - V_{EN_HYST} is the enable threshold hysteresis
- (8)

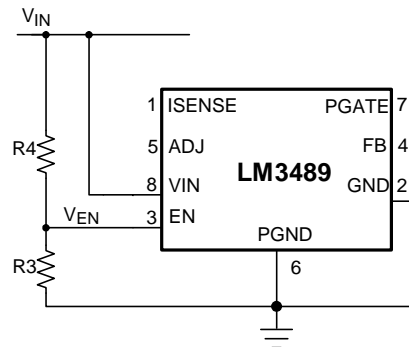

Copyright © 2016, Texas Instruments Incorporated

Figure 24. Adjustable UVLO

7.4 Device Functional Mode

7.4.1 Device Enable and Shutdown

The LM3489 can be remotely shutdown by forcing the enable pin to ground. With EN pin grounded, the internal blocks other than the enable logic are deactivated and the shutdown current of the device is lowered to only 7 μ A (typical). Releasing the EN pin allows for normal operation to resume. The EN pin is internally pulled high with the voltage clamped at 8 V typical. For normal operation, this pin must be left open. In case an external voltage source is applied to this pin for enable control, the applied voltage must not exceed the maximum operating voltage level specified in this datasheet (that is 5.5 V).

8 Application and Implementation

NOTE

Information in the following applications sections is not part of the TI component specification, and TI does not warrant its accuracy or completeness. TI's customers are responsible for determining suitability of components for their purposes. Customers should validate and test their design implementation to confirm system functionality.

8.1 Application Information

Hysteretic control is a simple control scheme. However the operating frequency and other performance characteristics highly depend on external conditions and components. If either the inductance, output capacitance, ESR, V_{IN} , or C_{ff} is changed, there is a change in the operating frequency and output ripple. The best approach is to determine what operating frequency is desirable in the application and then begin with the selection of the inductor and C_{OUT} ESR.

8.2 Typical Application

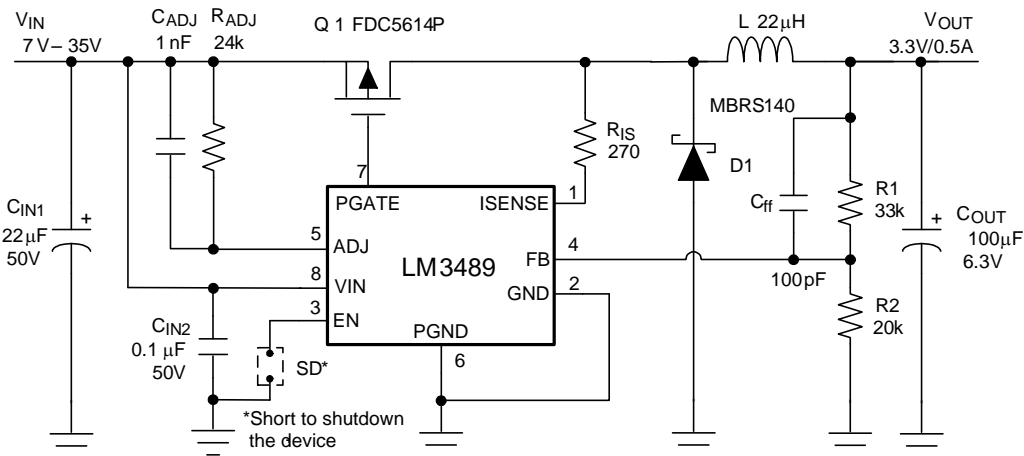

Copyright © 2016, Texas Instruments Incorporated

Figure 25. Typical Application Schematic for $V_{OUT} = 3.3\text{ V}$, 500 mA

8.2.1 Design Requirements

The important parameters for the inductor are the inductance and the current rating. The LM3489 operates over a wide frequency range and can use a wide range of inductance values. A rule of thumb is to use the equations used for Simple Switchers[®]. The equations for inductor ripple (Δi) as a function of output current (I_{OUT}) depend on I_{out} :

$$\text{For } I_{out} < 2\text{ A, } \Delta i \leq I_{out} \times I_{out}^{-0.366726}.$$

$$\text{For } I_{out} > 2\text{ A, } \Delta i \leq I_{out} \times 0.3.$$

8.2.2 Detailed Design Procedure

8.2.2.1 Inductor Selection (L)

The inductance can be calculated with Equation 9 and Equation 10 based upon the desired operating frequency.

$$L = \frac{V_{IN} - V_{DS} - V_{OUT}}{\Delta i} \times \frac{D}{f} \quad (9)$$

Typical Application (continued)

$$I_{pk} = \left(I_{OUT} + \frac{\Delta i}{2} \right) \times 1.1$$

where

- D is the duty cycle
 - V_D is the diode forward voltage
 - V_{DS} is the voltage drop across the PFET
- (10)

The inductor must be rated with [Equation 11](#).

$$I_{pk} = \left(I_{OUT} + \frac{\Delta i}{2} \right) \times 1.1$$
(11)

The inductance value and the resulting ripple is one of the key parameters controlling operating frequency. The second is the inductor ESR that contribute to the steady-state power loss due to current flowing through the inductor.

8.2.2.2 Output Capacitor Selection (C_{OUT})

The ESR of the output capacitor times the inductor ripple current is equal to the output ripple of the regulator. However, the V_{HYST} sets the first-order value of this ripple. As ESR is increased with a given inductance, operating frequency increases as well. If ESR is reduced then the operating frequency reduces.

The use of ceramic capacitors has become a common desire of many power supply designers. However, ceramic capacitors have a very low ESR resulting in a 90° phase shift of the output voltage ripple. This results in low operating frequency and increased output ripple. To fix this problem a low-value resistor must be added in series with the ceramic output capacitor. Although counter intuitive, this combination of a ceramic capacitor and external series resistance provides highly accurate control over the output voltage ripple. Other types capacitor, such as Sanyo POS CAP and OS-CON, Panasonic SP CAP, and Nichicon NA series, are also recommended and may be used without additional series resistance.

For all practical purposes, any type of output capacitor may be used with proper circuit verification.

8.2.2.3 Input Capacitor Selection (C_{IN})

A bypass capacitor is required between the input source and ground. It must be located near the source pin of the external PFET. The input capacitor prevents large voltage transients at the input and provides the instantaneous current when the PFET turns on.

The important parameters for the input capacitor are the voltage rating and the RMS current rating. Follow the manufacturer's recommended voltage derating. For high-input voltage applications, low-ESR electrolytic, Nichicon UD series or the Panasonic FK series are available. The RMS current in the input capacitor can be calculated with [Equation 12](#).

$$I_{RMS_CIN} = I_{OUT} \times \frac{\sqrt{V_{OUT}(V_{IN} - V_{OUT})}}{V_{IN}}$$
(12)

The input capacitor power dissipation can be calculated with [Equation 13](#).

$$P_{D(CIN)} = I_{RMS_CIN}^2 \times ESR_{CIN}$$
(13)

The input capacitor must be able to handle the RMS current and the dissipation. Several input capacitors may be connected in parallel to handle large RMS currents. In some cases it may be much cheaper to use multiple electrolytic capacitors than a single low-ESR, high-performance capacitor such as OS-CON or Tantalum. The capacitance value must be selected such that the ripple voltage created by the switch current pulses is less than 10% of the total DC voltage across the capacitor.

For high V_{IN} conditions (> 28 V), the fast switching, high swing of the internal gate drive introduces unwanted disturbance to the V_{IN} rail and the current limit function can be affected. To eliminate this potential problem, a high-quality ceramic capacitor of 0.1 μF is recommended to filter out the internal disturbance at the V_{IN} pin. This capacitor must be placed right next to the V_{IN} pin for best performance.

Typical Application (continued)

8.2.2.4 Programming the Current Limit (R_{ADJ})

The current limit is determined with [Equation 14](#) by connecting a resistor (R_{ADJ}) between input voltage and the ADJ pin, pin 5.

$$R_{ADJ} = I_{IND_PEAK} \times \frac{R_{DSON}}{I_{CL_ADJ}}$$

where

- R_{DSON} is Drain-Source ON resistance of the external PFET
- I_{CL_ADJ} is 3 μ A minimum
- $I_{IND_PEAK} = I_{LOAD} + I_{RIPPLE} / 2$ (14)

Using the minimum value for I_{CL_ADJ} (3 μ A) ensures that the current limit threshold is set higher than the peak inductor current.

The R_{ADJ} value must be selected to ensure that the voltage at the ADJ pin does not fall below 3.5 V. With this in mind, $R_{ADJ_MAX} = (V_{IN} - 3.5) / 7 \mu$ A. If a larger R_{ADJ} value is needed to set the desired current limit, either use a PFET with a lower R_{DSON} or use a current sense resistor as shown in [Figure 23](#).

The current limit function can be disabled by connecting the ADJ pin to ground and ISENSE to VIN.

8.2.2.5 Catch Diode Selection (D1)

The important parameters for the catch diode are the peak current, the peak reverse voltage, and the average power dissipation. The average current through the diode can be calculated with [Equation 15](#).

$$I_{D_AVE} = I_{OUT} \times (1 - D) \tag{15}$$

The off-state voltage across the catch diode is approximately equal to the input voltage. The peak reverse voltage rating must be greater than input voltage. In nearly all cases a Schottky diode is recommended. In low-output voltage applications, a low forward voltage provides improved efficiency. For high-temperature applications, diode leakage current may become significant and require a higher reverse voltage rating to achieve acceptable performance.

8.2.2.6 P-Channel MOSFET Selection (Q1)

The important parameters for the PFET are the maximum Drain-Source voltage (V_{DS}), the ON resistance (R_{DSON}), Current rating, and the input capacitance.

The voltage across the PFET when it is turned off is equal to the sum of the input voltage and the diode forward voltage. The V_{DS} must be selected to provide some margin beyond the input voltage.

PFET drain current, I_d , must be rated higher than the peak inductor current, I_{IND_PEAK} .

Depending on operating conditions, the PGATE voltage may fall as low as $V_{IN} - 8.3$ V. Therefore, a PFET must be selected with a V_{GS} maximum rating greater than the maximum PGATE swing voltage.

As input voltage decreases below 9 V, PGATE swing voltage may also decrease. At 5-V input the PGATE will swing from V_{IN} to $V_{IN} - 4.6$ V. To ensure that the PFET turns on quickly and completely, a low threshold PFET must be used when the input voltage is less than 7 V.

Total power loss in the FET can be approximated using [Equation 16](#).

$$PD_{switch} = R_{DSON} \times I_{OUT}^2 \times D + F \times I_{OUT} \times V_{IN} \times (t_{on} + t_{off}) / 2$$

where

- t_{on} is the FET turn on time
- t_{off} is the FET turn off time (16)

A value of 10 ns to 20 ns is typical for t_{on} and t_{off} .

A PFET must be selected with a turnon rise time of less than 100 ns. Slower rise times will degrade efficiency, can cause false current limiting, and in extreme cases may cause abnormal spiking at the PGATE pin.

Typical Application (continued)

The $R_{DS(ON)}$ is used in determining the current limit resistor value, R_{ADJ} . Note that the $R_{DS(ON)}$ has a positive temperature coefficient. At 100°C, the $R_{DS(ON)}$ may be as much as 150% higher than the 25°C value. This increase in $R_{DS(ON)}$ must be considered when determining R_{ADJ} in wide temperature range applications. If the current limit is set based upon 25°C ratings, then false current limiting can occur at high temperature.

Keeping the gate capacitance below 2000 pF is recommended to keep switching losses and transition times low. This will also help keep the PFET drive current low, which will improve efficiency and lower the power dissipation within the controller.

As gate capacitance increases, operating frequency must be reduced and as gate capacitance decreases operating frequency can be increased.

8.2.2.7 Interfacing With the Enable Pin

The enable pin is internally pulled high with clamping at 8 V typical. For normal operation this pin must be left open. To disable the device, the enable pin must be connected to ground externally. If an external voltage source is applied to this pin for enable control, the applied voltage must not exceed the maximum operating voltage level specified in this datasheet, that is 5.5 V. For most applications, an open-drain or open-collector transistor can be used to short this pin to ground to shutdown the device .

8.2.3 Application Curves

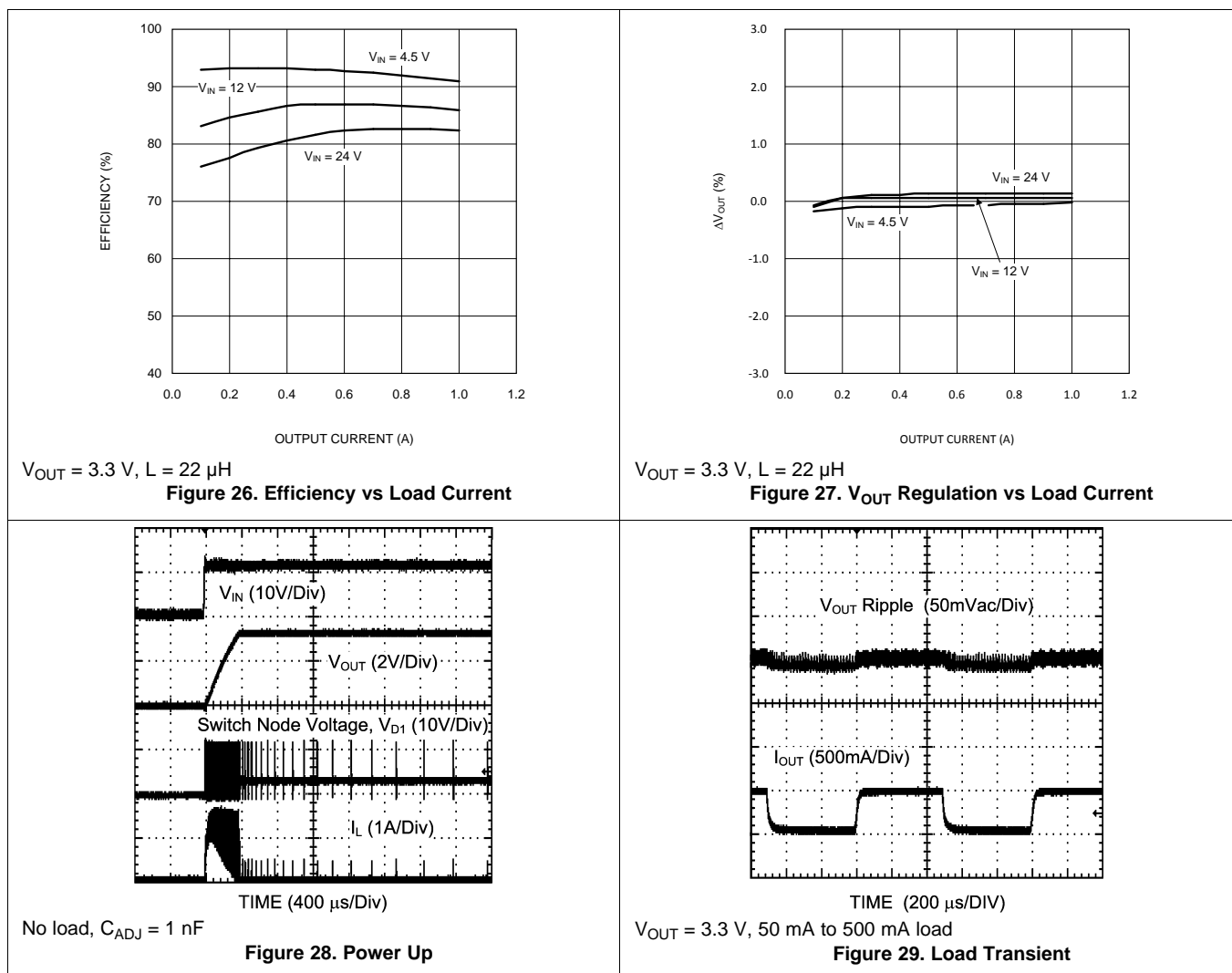

9 Power Supply Recommendations

This device is designed to operate over a recommended input voltage supply range of 4.5 V to 35 V. The input supply must be well regulated. If the input supply is located far from the LM3489 EVM and needs a long power supply cable to connect, an additional bulk capacitor may be required. An electrolytic capacitor with a value of 47 μF can be used typically.

As mentioned in [Current Limit Operation](#), at higher input voltages ($> 28\text{ V}$) an increased negative SW transient spike at the switch node can lead to an increase in the current limit threshold due to the formation of the parasitic NPN connection between the ISENSE pin, the internal substrate and the ADJ pin. To avoid this issue, a Schottky catch diode with lower forward voltage drop must be used. In addition to that, a resistor must be placed between the ISENSE pin and the external switch node. A resistor value in the range of 220 Ω to 600 Ω is recommended.

10 Layout

10.1 Layout Guidelines

The PCB layout is very important in all switching regulator designs. Poor layout can cause switching noise into the feedback signal and generate EMI problems. For minimal inductance, the wires indicated by heavy lines in schematic diagram must be as wide and short as possible. Keep the ground pin of the input capacitor as close as possible to the anode of the catch diode. This path carries a large AC current. The switching node, the node with the diode cathode, inductor and FET drain must be kept short. This node is one of the main sources for radiated EMI since it sees a large AC voltage at the switching frequency. It is always a good practice to use a ground plane in the design, particularly for high-current applications.

The two ground pins, PGND and GND, must be connected by as short a trace as possible. They can be connected underneath the device. These pins are resistively connected internally by approximately 50 Ω . The ground pins must be tied to the ground plane, or to a large ground trace in close proximity to both the FB divider and C_{OUT} grounds.

The gate pin of the external PFET must be placed close to the PGATE pin. However, if a very small FET is used, a resistor may be required between PGATE pin and the gate of the PFET to reduce high-frequency ringing. Because this resistor will slow down the PFET's rise time, the current limit blanking time must be taken into consideration (see [Current Limit Operation](#)). The feedback voltage signal line can be sensitive to noise. Avoid inductive coupling with the inductor or the switching node. The FB trace must be kept away from those areas. Also, the orientation of the inductor can contribute un-wanted noise coupling to the FB path. If noise problems are observed it may be worth trying a different orientation of the inductor and select the best for final component placement.

10.2 Layout Examples

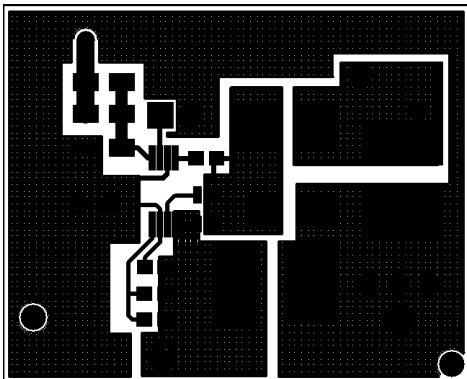

Figure 30. LM3489 EVM PCB Top Layer Layout

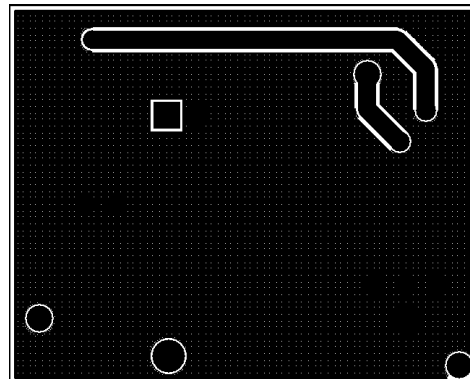

Figure 31. LM3489 EVM PCB Bottom Layer Layout

11 Device and Documentation Support

11.1 Related Links

The table below lists quick access links. Categories include technical documents, support and community resources, tools and software, and quick access to sample or buy.

Table 1. Related Links

PARTS	PRODUCT FOLDER	SAMPLE & BUY	TECHNICAL DOCUMENTS	TOOLS & SOFTWARE	SUPPORT & COMMUNITY
LM3489	Click here	Click here	Click here	Click here	Click here
LM3489-Q1	Click here	Click here	Click here	Click here	Click here

11.2 Receiving Notification of Documentation Updates

To receive notification of documentation updates, navigate to the device product folder on ti.com. In the upper right corner, click on *Alert me* to register and receive a weekly digest of any product information that has changed. For change details, review the revision history included in any revised document.

11.3 Community Resources

The following links connect to TI community resources. Linked contents are provided "AS IS" by the respective contributors. They do not constitute TI specifications and do not necessarily reflect TI's views; see TI's [Terms of Use](#).

TI E2E™ Online Community *TI's Engineer-to-Engineer (E2E) Community*. Created to foster collaboration among engineers. At e2e.ti.com, you can ask questions, share knowledge, explore ideas and help solve problems with fellow engineers.

Design Support *TI's Design Support* Quickly find helpful E2E forums along with design support tools and contact information for technical support.

11.4 Trademarks

E2E is a trademark of Texas Instruments.
Simple Switchers is a registered trademark of Texas Instruments.
All other trademarks are the property of their respective owners.

11.5 Electrostatic Discharge Caution



These devices have limited built-in ESD protection. The leads should be shorted together or the device placed in conductive foam during storage or handling to prevent electrostatic damage to the MOS gates.

11.6 Glossary

[SLYZ022](#) — *TI Glossary*.

This glossary lists and explains terms, acronyms, and definitions.

12 Mechanical, Packaging, and Orderable Information

The following pages include mechanical, packaging, and orderable information. This information is the most current data available for the designated devices. This data is subject to change without notice and revision of this document. For browser-based versions of this data sheet, refer to the left-hand navigation.

PACKAGING INFORMATION

Orderable Device	Status (1)	Package Type	Package Drawing	Pins	Package Qty	Eco Plan (2)	Lead finish/ Ball material (6)	MSL Peak Temp (3)	Op Temp (°C)	Device Marking (4/5)	Samples
LM3489MM	NRND	VSSOP	DGK	8	1000	Non-RoHS & Green	Call TI	Level-1-260C-UNLIM	-40 to 125	SKSB	
LM3489MM/NOPB	ACTIVE	VSSOP	DGK	8	1000	RoHS & Green	NIPDAUAG SN	Level-1-260C-UNLIM	-40 to 125	SKSB	Samples
LM3489MMX/NOPB	ACTIVE	VSSOP	DGK	8	3500	RoHS & Green	NIPDAUAG SN	Level-1-260C-UNLIM	-40 to 125	SKSB	Samples
LM3489QMM/NOPB	ACTIVE	VSSOP	DGK	8	1000	RoHS & Green	SN	Level-1-260C-UNLIM	-40 to 125	STEB	Samples
LM3489QMMX/NOPB	ACTIVE	VSSOP	DGK	8	3500	RoHS & Green	SN	Level-1-260C-UNLIM	-40 to 125	STEB	Samples

(1) The marketing status values are defined as follows:

ACTIVE: Product device recommended for new designs.

LIFEBUY: TI has announced that the device will be discontinued, and a lifetime-buy period is in effect.

NRND: Not recommended for new designs. Device is in production to support existing customers, but TI does not recommend using this part in a new design.

PREVIEW: Device has been announced but is not in production. Samples may or may not be available.

OBSOLETE: TI has discontinued the production of the device.

(2) **RoHS:** TI defines "RoHS" to mean semiconductor products that are compliant with the current EU RoHS requirements for all 10 RoHS substances, including the requirement that RoHS substance do not exceed 0.1% by weight in homogeneous materials. Where designed to be soldered at high temperatures, "RoHS" products are suitable for use in specified lead-free processes. TI may reference these types of products as "Pb-Free".

RoHS Exempt: TI defines "RoHS Exempt" to mean products that contain lead but are compliant with EU RoHS pursuant to a specific EU RoHS exemption.

Green: TI defines "Green" to mean the content of Chlorine (Cl) and Bromine (Br) based flame retardants meet JS709B low halogen requirements of <=1000ppm threshold. Antimony trioxide based flame retardants must also meet the <=1000ppm threshold requirement.

(3) MSL, Peak Temp. - The Moisture Sensitivity Level rating according to the JEDEC industry standard classifications, and peak solder temperature.

(4) There may be additional marking, which relates to the logo, the lot trace code information, or the environmental category on the device.

(5) Multiple Device Markings will be inside parentheses. Only one Device Marking contained in parentheses and separated by a "~" will appear on a device. If a line is indented then it is a continuation of the previous line and the two combined represent the entire Device Marking for that device.

(6) Lead finish/Ball material - Orderable Devices may have multiple material finish options. Finish options are separated by a vertical ruled line. Lead finish/Ball material values may wrap to two lines if the finish value exceeds the maximum column width.

Important Information and Disclaimer: The information provided on this page represents TI's knowledge and belief as of the date that it is provided. TI bases its knowledge and belief on information provided by third parties, and makes no representation or warranty as to the accuracy of such information. Efforts are underway to better integrate information from third parties. TI has taken and continues to take reasonable steps to provide representative and accurate information but may not have conducted destructive testing or chemical analysis on incoming materials and chemicals. TI and TI suppliers consider certain information to be proprietary, and thus CAS numbers and other limited information may not be available for release.

In no event shall TI's liability arising out of such information exceed the total purchase price of the TI part(s) at issue in this document sold by TI to Customer on an annual basis.

OTHER QUALIFIED VERSIONS OF LM3489, LM3489-Q1 :

- Catalog : [LM3489](#)
- Automotive : [LM3489-Q1](#)

NOTE: Qualified Version Definitions:

- Catalog - TI's standard catalog product
- Automotive - Q100 devices qualified for high-reliability automotive applications targeting zero defects

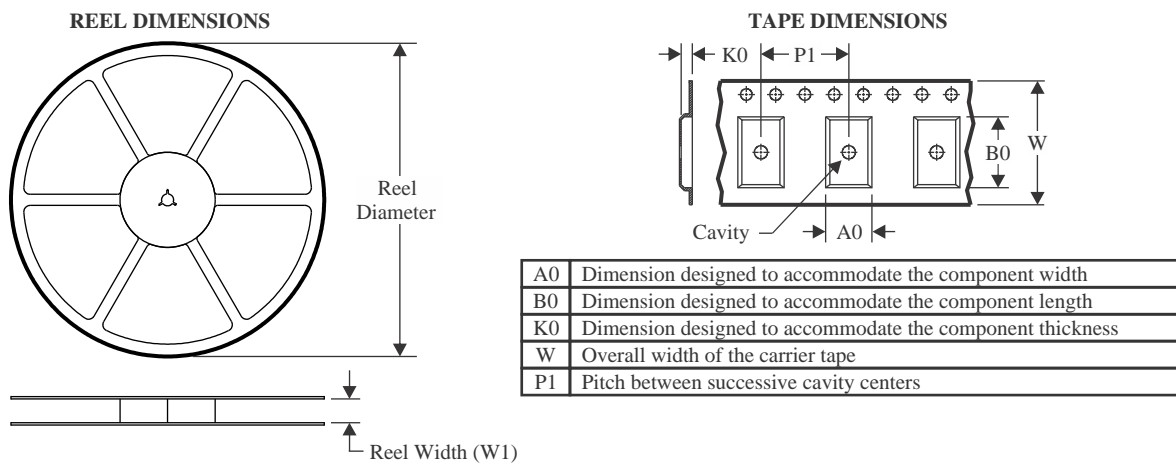
TAPE AND REEL INFORMATION

QUADRANT ASSIGNMENTS FOR PIN 1 ORIENTATION IN TAPE

*All dimensions are nominal

Device	Package Type	Package Drawing	Pins	SPQ	Reel Diameter (mm)	Reel Width W1 (mm)	A0 (mm)	B0 (mm)	K0 (mm)	P1 (mm)	W (mm)	Pin1 Quadrant
LM3489MM	VSSOP	DGK	8	1000	178.0	12.4	5.3	3.4	1.4	8.0	12.0	Q1
LM3489MM/NOPB	VSSOP	DGK	8	1000	178.0	12.4	5.3	3.4	1.4	8.0	12.0	Q1
LM3489MMX/NOPB	VSSOP	DGK	8	3500	330.0	12.4	5.3	3.4	1.4	8.0	12.0	Q1
LM3489QMM/NOPB	VSSOP	DGK	8	1000	178.0	12.4	5.3	3.4	1.4	8.0	12.0	Q1
LM3489QMMX/NOPB	VSSOP	DGK	8	3500	330.0	12.4	5.3	3.4	1.4	8.0	12.0	Q1

TAPE AND REEL BOX DIMENSIONS

*All dimensions are nominal

Device	Package Type	Package Drawing	Pins	SPQ	Length (mm)	Width (mm)	Height (mm)
LM3489MM	VSSOP	DGK	8	1000	208.0	191.0	35.0
LM3489MM/NOPB	VSSOP	DGK	8	1000	208.0	191.0	35.0
LM3489MMX/NOPB	VSSOP	DGK	8	3500	367.0	367.0	35.0
LM3489QMM/NOPB	VSSOP	DGK	8	1000	208.0	191.0	35.0
LM3489QMMX/NOPB	VSSOP	DGK	8	3500	367.0	367.0	35.0



- NOTES:
- A. All linear dimensions are in millimeters.
 - B. This drawing is subject to change without notice.
 - C. Publication IPC-7351 is recommended for alternate designs.
 - D. Laser cutting apertures with trapezoidal walls and also rounding corners will offer better paste release. Customers should contact their board assembly site for stencil design recommendations. Refer to IPC-7525 for other stencil recommendations.
 - E. Customers should contact their board fabrication site for solder mask tolerances between and around signal pads.

IMPORTANT NOTICE AND DISCLAIMER

TI PROVIDES TECHNICAL AND RELIABILITY DATA (INCLUDING DATA SHEETS), DESIGN RESOURCES (INCLUDING REFERENCE DESIGNS), APPLICATION OR OTHER DESIGN ADVICE, WEB TOOLS, SAFETY INFORMATION, AND OTHER RESOURCES "AS IS" AND WITH ALL FAULTS, AND DISCLAIMS ALL WARRANTIES, EXPRESS AND IMPLIED, INCLUDING WITHOUT LIMITATION ANY IMPLIED WARRANTIES OF MERCHANTABILITY, FITNESS FOR A PARTICULAR PURPOSE OR NON-INFRINGEMENT OF THIRD PARTY INTELLECTUAL PROPERTY RIGHTS.

These resources are intended for skilled developers designing with TI products. You are solely responsible for (1) selecting the appropriate TI products for your application, (2) designing, validating and testing your application, and (3) ensuring your application meets applicable standards, and any other safety, security, regulatory or other requirements.

These resources are subject to change without notice. TI grants you permission to use these resources only for development of an application that uses the TI products described in the resource. Other reproduction and display of these resources is prohibited. No license is granted to any other TI intellectual property right or to any third party intellectual property right. TI disclaims responsibility for, and you will fully indemnify TI and its representatives against, any claims, damages, costs, losses, and liabilities arising out of your use of these resources.

TI's products are provided subject to [TI's Terms of Sale](#) or other applicable terms available either on ti.com or provided in conjunction with such TI products. TI's provision of these resources does not expand or otherwise alter TI's applicable warranties or warranty disclaimers for TI products.

TI objects to and rejects any additional or different terms you may have proposed.

Mailing Address: Texas Instruments, Post Office Box 655303, Dallas, Texas 75265
Copyright © 2022, Texas Instruments Incorporated