

## LMV232 Dual-Channel Integrated Mean Square Power Detector for CDMA & WCDMA

Check for Samples: [LMV232](#)

### FEATURES

- >20 dB Square-Law Detection Range
- 2 Sequentially Selectable RF Inputs
- Low Power Consumption Shutdown Mode
- Externally Configurable Gain and LF Filter Bandwidth.
- Internal 50Ω RF Termination Impedance
- Optimized for Use with 20 dB Directional Coupler
- Lead Free 8-Bump DSBGA Package 1.5 x 1.5 x 0.6 mm

### APPLICATIONS

- 3G Mobile Communications
- UMTS
- WCDMA
- CDMA2000
- TD-SCDMA
- RF Control
- Wireless LAN
- PC Card and GPS Modules

### DESCRIPTION

The LMV232 dual RF detector is designed for RF transmit power measurement in mobile phones. This dual mean square IC is especially suited for accurate power measurement of RF signals exhibiting high peak-to-average ratios used in 3G and UMTS/CDMA applications. The LMV232 saves calibration steps and system certification and is highly accurate. The circuit operates with a single supply from 2.5 to 3.3V.

The LMV232 contains a mean square detector with two sequentially selectable RF inputs. The RF input power range of the device has been optimized for use with a 20 dB directional coupler, without the need for additional external components. A single external RC combination between FB and OUT provides an externally configurable gain and LF filter bandwidth of the device.

The device has two digital interfaces. A shutdown function is available to set the device in a low-power shutdown mode. In case SD = HIGH, the device is in shutdown, if SD = LOW the device is active. The Band-Select function controls the selection of the active RF input channel. In case BS = HIGH, RF<sub>IN1</sub> is active. In case BS = LOW, RF<sub>IN2</sub> is active.

The dual mean square detector is offered in an 8-bump DSBGA 1.5 x 1.5 x 0.6 mm package. This DSBGA package has the smallest footprint and height.

### TYPICAL APPLICATION

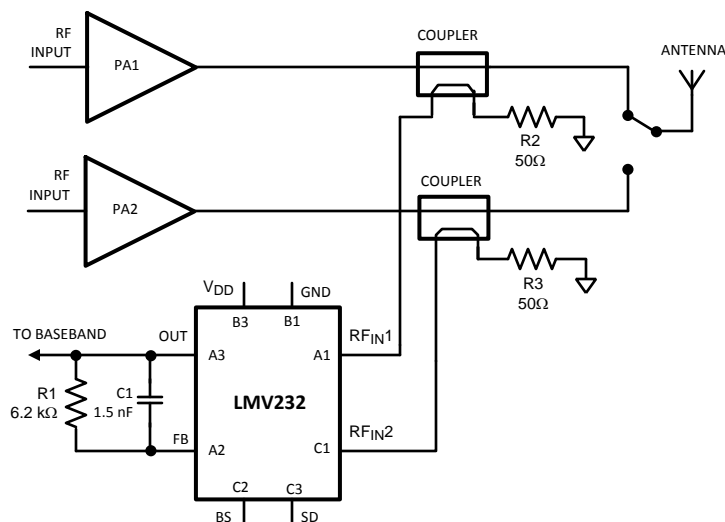

Please be aware that an important notice concerning availability, standard warranty, and use in critical applications of Texas Instruments semiconductor products and disclaimers thereto appears at the end of this data sheet.



These devices have limited built-in ESD protection. The leads should be shorted together or the device placed in conductive foam during storage or handling to prevent electrostatic damage to the MOS gates.

## ABSOLUTE MAXIMUM RATINGS <sup>(1)(2)</sup>

Supply Voltage	V <sub>DD</sub> - GND	3.6V Max
ESD Tolerance <sup>(3)</sup>	Human Body Model	2000V
	Machine Model	200V
Storage Temperature Range		-65°C to 150°C
Junction Temperature <sup>(4)</sup>		150°C Max
Mounting Temperature	Infrared or Convection (20 sec)	235°C

- (1) Absolute Maximum Ratings indicate limits beyond which damage to the device may occur. Operating Ratings indicate conditions for which the device is intended to be functional, but specific performance is not ensured. For ensured specifications and the test conditions, see the Electrical Characteristics.
- (2) If Military/Aerospace specified devices are required, please contact the TI Sales Office/ Distributors for availability and specifications.
- (3) Human body model: 1.5 kΩ in series with 100 pF. Machine model, 0Ω in series with 100 pF.
- (4) The maximum power dissipation is a function of T<sub>J(MAX)</sub>, θ<sub>JA</sub> and T<sub>A</sub>. The maximum allowable power dissipation at any ambient temperature is P<sub>D</sub> = (T<sub>J(MAX)</sub> - T<sub>A</sub>)/θ<sub>JA</sub>. All numbers apply for packages soldered directly into a PC board.

## OPERATING RATINGS <sup>(1)</sup>

Supply Voltage	2.5V to 3.3V
Operating Temperature Range	-40°C to +85°C
RF Frequency Range	50 MHz to 2 GHz

- (1) Absolute Maximum Ratings indicate limits beyond which damage to the device may occur. Operating Ratings indicate conditions for which the device is intended to be functional, but specific performance is not ensured. For ensured specifications and the test conditions, see the Electrical Characteristics.

## 2.7 DC AND AC ELECTRICAL CHARACTERISTICS

Unless otherwise specified, all limits are specified to V<sub>DD</sub> = 2.7V; T<sub>J</sub> = 25°C. **Boldface** limits apply at temperature extremes. <sup>(1)</sup>

Symbol	Parameter	Condition	Min	Typ	Max	Units
I <sub>DD</sub>	Supply Current	Active Mode: SD = LOW, No RF Input Power Present		9.8	11 <b>13</b>	mA
		Shutdown: SD = 1.8V, No RF Input Power Present		0.09	5 <b>30</b>	μA
V <sub>LOW</sub>	BS and SD Logic Low Level <sup>(2)</sup>				<b>0.8</b>	V
V <sub>HIGH</sub>	BS and SD Logic High Level <sup>(2)</sup>		<b>1.8</b>			V
I <sub>BS</sub> , I <sub>SD</sub>	Current into BS and SD pins				<b>5</b>	μA
V <sub>OUT</sub>	Output Voltage Swing	From Positive Rail, Sourcing, FB = 0V, I <sub>OUT</sub> = 1 mA		20	80 <b>90</b>	mV
		From Negative Rail, Sinking, FB = 2.7V, I <sub>OUT</sub> = -1 mA		20	60 <b>70</b>	mV
I <sub>OUT</sub>	Output Short Circuit	Sourcing, FB = 0V, V <sub>OUT</sub> = 2.6V	3.7 <b>2.7</b>	5.1		mA
		Sinking, FB = 2.7V, V <sub>OUT</sub> = 0.1V	3.7 <b>2.7</b>	5.5		
V <sub>OUT</sub>	Output Voltage (Pedestal)	No RF Input Power	235 <b>230</b>	254	275 <b>280</b>	mV
V <sub>PED</sub>	Pedestal Variation Over Temperature <sup>(3)</sup>			5.4		mV
I <sub>OS</sub>	Offset Current Variation Over Temperature <sup>(3)</sup>			1.17		μA

- (1) Electrical Table values apply only for factory testing conditions at the temperature indicated. Factory testing conditions result in very limited self-heating of the device such that T<sub>J</sub> = T<sub>A</sub>. No ensured specification of parametric performance is indicated in the electrical tables under conditions of internal self-heating where T<sub>J</sub> > T<sub>A</sub>.
- (2) All limits are specified by design or statistical analysis.
- (3) Typical numbers represent the 3-sigma value of 10k units. 3-sigma value of variation between -40°C / 25°C and variation between 25°C / 85°C.

## 2.7 DC AND AC ELECTRICAL CHARACTERISTICS (continued)

Unless otherwise specified, all limits are specified to  $V_{DD} = 2.7V$ ;  $T_J = 25^\circ C$ . **Boldface** limits apply at temperature extremes. <sup>(1)</sup>

Symbol	Parameter	Condition	Min	Typ	Max	Units
$t_{ON}$	Turn-on-Time <sup>(4)</sup>	No RF Input Power Present, Output Loaded with 10 pF		2.0	6.0	$\mu s$
$t_R$	Rise Time <sup>(5)</sup>	Step from No Power to 0 dBm Applied, Output Loaded with 10 pF		4.5		$\mu s$
$e_n$	Output Referred Voltage Noise	RF Input = 1800 MHz, -10 dBm, Measured at 10 kHz		400		$nV/\sqrt{Hz}$
GBW	Gain Bandwidth Product			3.7		MHz
SR	Slew Rate		1.8 <b>1.0</b>	3.0		$V/\mu s$
$R_{IN}$	DC Resistance	See <sup>(5)</sup>		50.8		$\Omega$
$P_{IN}$	RF Input Power Range <sup>(6)(7)</sup>	RF Input Frequency = 900 MHz		-11 +13		dBm
				-24 0		dBV
$K_{DET}$	Detection Slope	900 MHz		21		$\mu A/mW$
		1800 MHz		10		
		1900 MHz		10		
		2000 MHz		10		
$f_{LOW}$	LF Input Corner Frequency	Lower -3 dB Point of Detection Slope		60		MHz
$f_{HIGH}$	HF Input Corner Frequency	Upper -3 dB Point of Detection Slope		1.0		GHz
$A_{ISO}$	Channel Isolation	900 MHz		58		dB
		1800 MHz		62		
		1900 MHz		58		
		2000 MHz		55		

- (4) Turn-on time is measured by connecting a 10 k $\Omega$  resistor to the  $RF_{IN}/E_N$  pin. Be aware that in the actual application on the front page, the RC-time constant of resistor R2 and capacitor C adds an additional delay.
- (5) Typical values represent the most likely parametric norm.
- (6) Power in dBV = dBm + 13 when the impedance is 50 $\Omega$ .
- (7) Device is set in active mode with a 10 k $\Omega$  resistor from  $V_{DD}$  to  $RF_{IN}/E_N$ . RF signal is applied using a 50 $\Omega$  RF signal generator AC coupled to the  $RF_{IN}/E_N$  pin using a 100 pF coupling capacitor.

### CONNECTION DIAGRAM

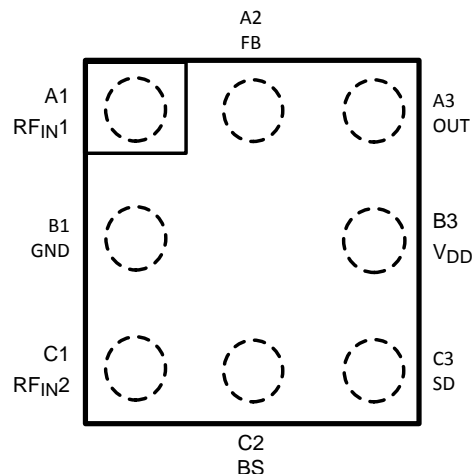
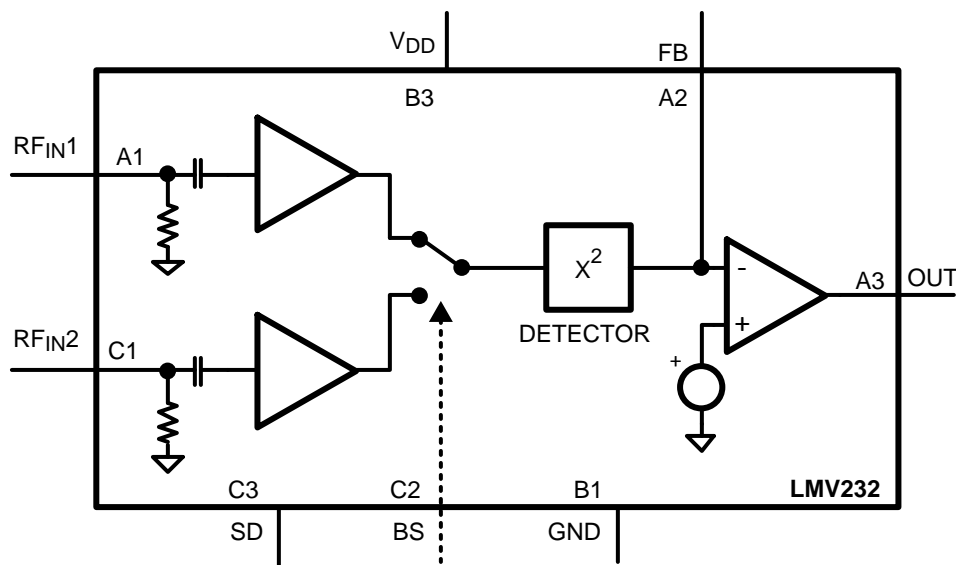

Figure 1. 8-Bump DSBGA - Top View

**Table 1. PIN DESCRIPTION**

	Pin	Name	Description
Power Supply	B3	V <sub>DD</sub>	Positive Supply Voltage
	B1	GND	Power Ground
Digital Inputs	C3	SD	Schmitt-triggered Shutdown. The device is active for SD = LOW. For SD = HIGH, it is brought into a low-power shutdown mode.
	C2	BS	Schmitt-triggered Band Select pin. When BS = HIGH, RF <sub>IN1</sub> is selected, when BS = LOW, RF <sub>IN2</sub> is selected.
Analog Inputs	A1	RF <sub>IN1</sub>	RF Input connected to the coupler output with optional attenuation to measure the Power Amplifier (PA) / Antenna RF power levels. Both RF inputs of the device are internally terminated with a 50Ω resistance.
	C1	RF <sub>IN2</sub>	
Feedback	A2	FB	Connected to inverting input of output amplifier. Enables user-configurable gain and bandwidth through external feedback network.
Output	A3	Out	Amplifier output

**BLOCK DIAGRAMS**



**Figure 2. LMV232**

### TYPICAL PERFORMANCE CHARACTERISTICS

Unless otherwise specified,  $V_{DD} = 2.7V$ ,  $T_J = 25^\circ C$ ,  $R1 = 6.2\text{ k}\Omega$  and  $C1 = 1.5\text{ nF}$  (See [typical application](#)).

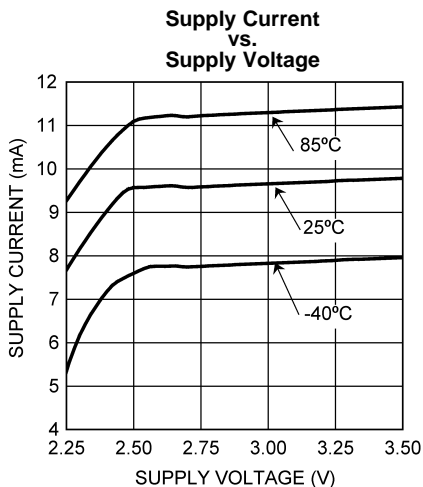

Figure 3.

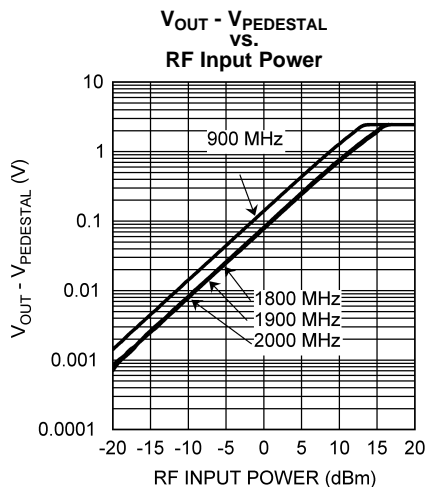

Figure 4.

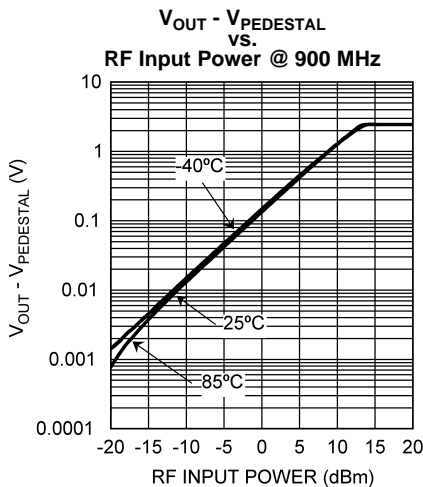

Figure 5.

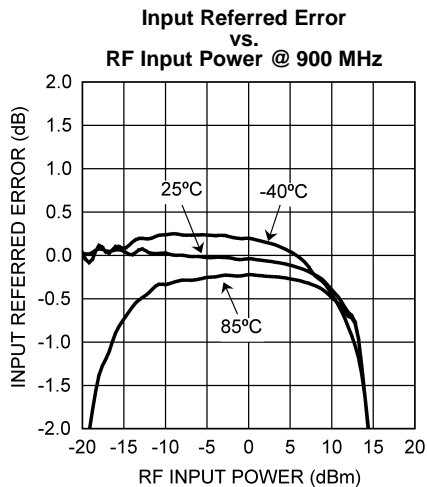

Figure 6.

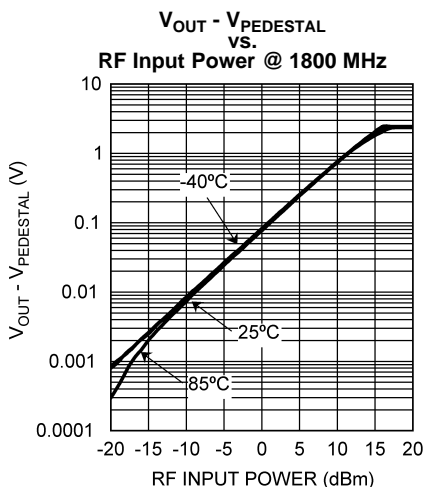

Figure 7.

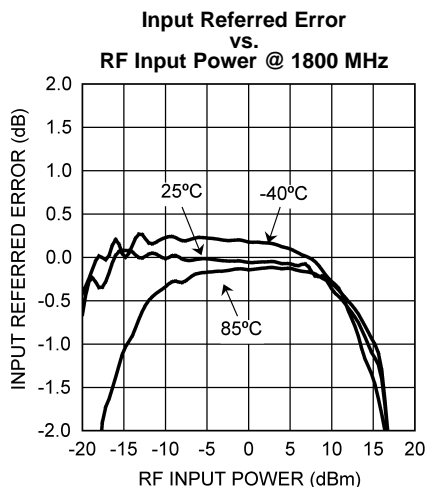

Figure 8.

**TYPICAL PERFORMANCE CHARACTERISTICS (continued)**

Unless otherwise specified,  $V_{DD} = 2.7V$ ,  $T_J = 25^\circ C$ ,  $R1 = 6.2\text{ k}\Omega$  and  $C1 = 1.5\text{ nF}$  (See [typical application](#)).

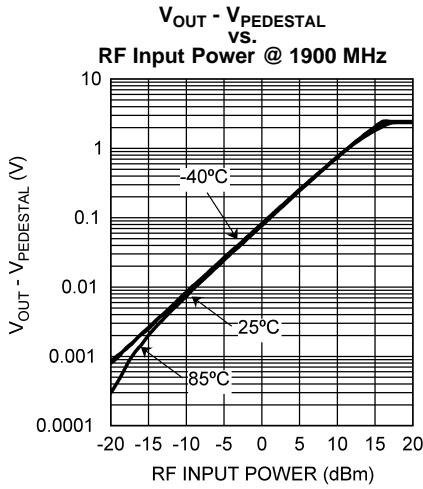

Figure 9.

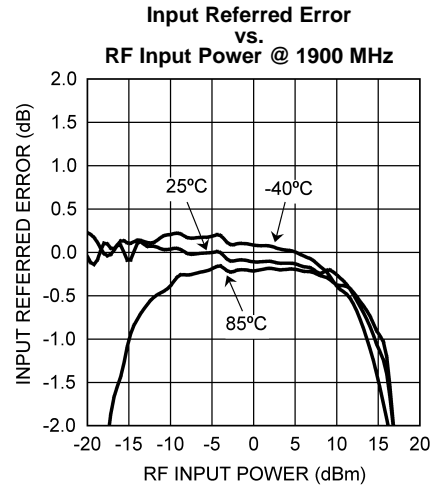

Figure 10.

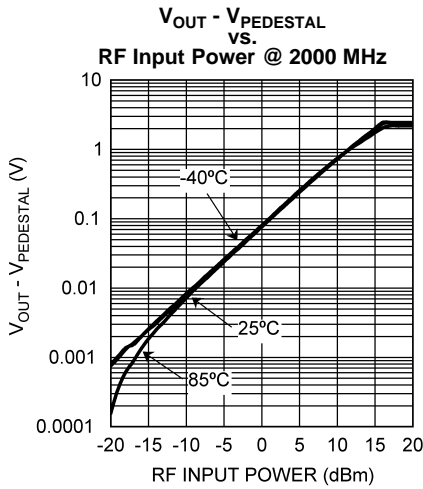

Figure 11.

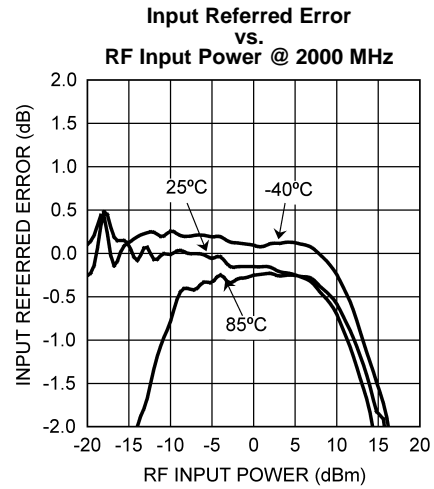

Figure 12.

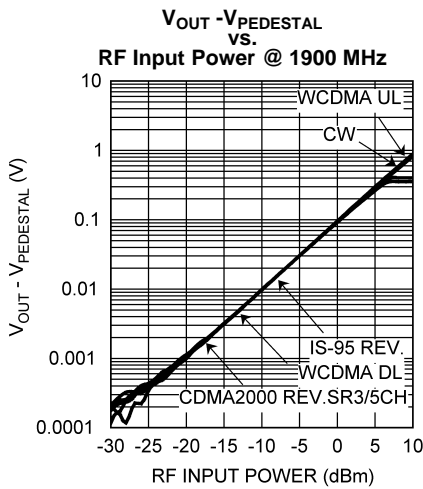

Figure 13.

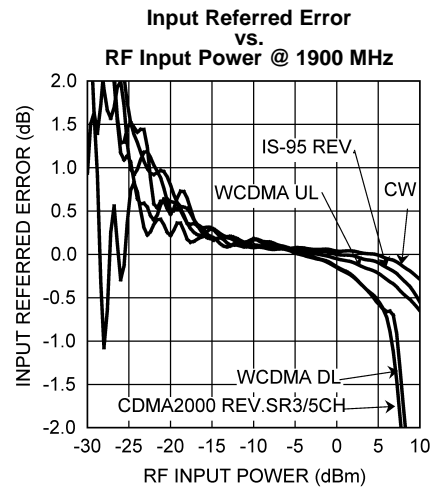

Figure 14.

**TYPICAL PERFORMANCE CHARACTERISTICS (continued)**

Unless otherwise specified,  $V_{DD} = 2.7V$ ,  $T_J = 25^\circ C$ ,  $R1 = 6.2\ k\Omega$  and  $C1 = 1.5\ nF$  (See [typical application](#)).

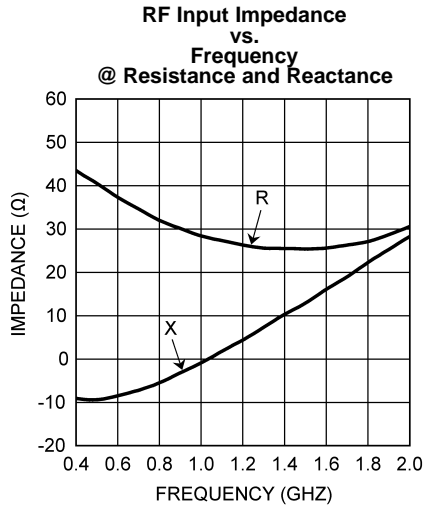

Figure 15.

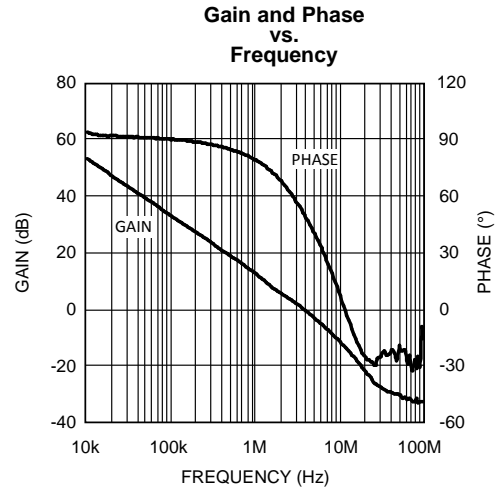

Figure 16.

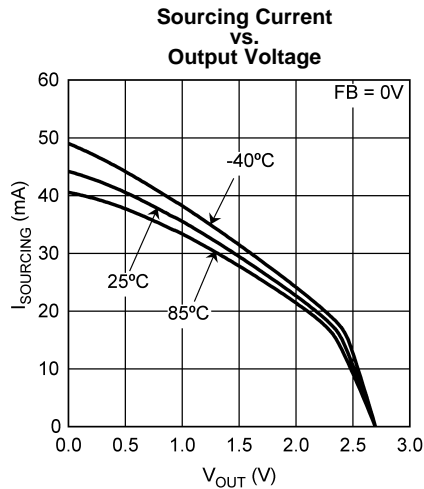

Figure 17.

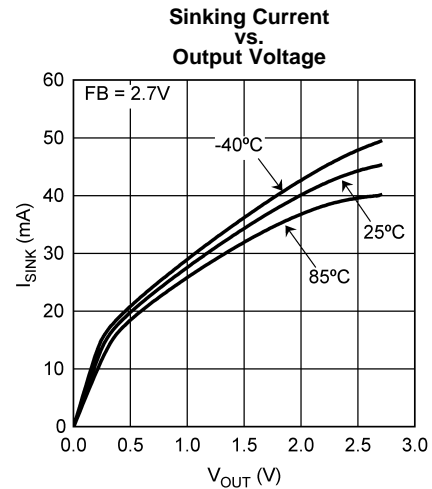

Figure 18.

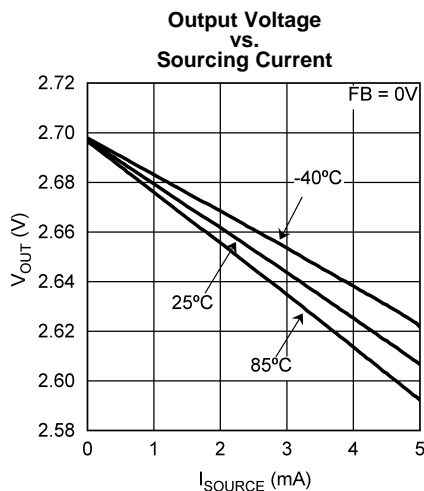

Figure 19.

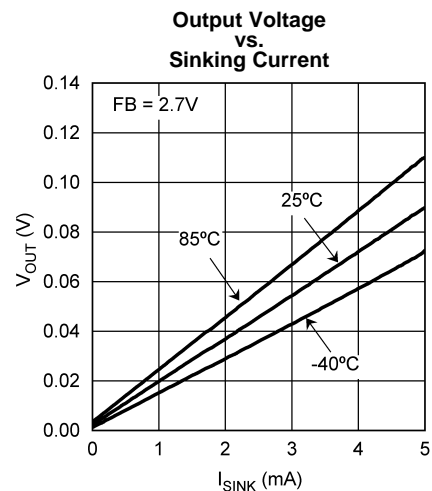

Figure 20.

## APPLICATION NOTES

The LMV232 mean square power detector is particularly suited for accurate power measurement of RF modulated signals that exhibit large peak to average ratios, i.e. large variations of the signal envelope. Such noise-like signals are encountered e.g. in CDMA and Wide-band CDMA cell-phones. Many power detection circuits, particularly those devised for constant-envelope modulated signals as in GSM, are based on peak detection and provide accurate power measurements for constant envelope or low-crest factor (ratio of peak to RMS) signals only. Such detectors are therefore not particularly suited for CDMA and WCDMA applications.

### TYPICAL APPLICATION

The LMV232 is especially suited for CDMA and WCDMA applications with 2 Power Amplifiers (PA's). A typical setup is given in [Figure 21](#). The output power of one PA is measured at a time, depending on the bandselect pin (BS). If the BS = High RF<sub>IN1</sub> is used for measurements, if BS = Low RF<sub>IN2</sub> is used. The measured output voltage of the LMV232 is read by the ADC of the baseband chip and the gain of the PA is adjusted if necessary. With an input impedance of 50Ω, the LMV232 can be directly connected to a 20 dB directional coupler without the need for an additional external attenuator. The setup can be adjusted to various PA output ranges by selection of a directional coupler or insertion of an additional (resistive) attenuator between the coupler outputs and the LMV232 RF inputs.

The LMV232 conversion gain and bandwidth are configured by a resistor and a capacitor. Resistor R1 sets the conversion gain from RF<sub>IN</sub> to the output voltage. A higher resistor value will result in a higher conversion gain. The maximum dynamic range is achieved when the resistor value is as high as possible, i.e. the output signal just doesn't clip and the voltage stays within the baseband ADC input range. The filter bandwidth is adjusted by capacitor C1. The capacitor value should be chosen such that the response time of the device is fast enough and modulation on the RF input signal is not visible at the output (ripple suppression). The -3 dB filter bandwidth of the output filter is determined by the time constant R1\*C1. Generally a capacitor value of 1.5 nF is a good choice.

### PEAK TO AVERAGE RATIO SENSITIVITY

The LMV232 power detector provides an accurate power measurement for arbitrary input signals, low and high peak-to-average ratios and crest factors. This is because its operation is not based on peak detection, but on direct determination of the mean square value. This is the most accurate power measurement, since it exactly implements the definition of power. A mean-square detector measures  $V_{RMS}^2$  for all waveforms. Peak detection is less accurate because the relation between peak detection and mean square detection depends on the waveform. A peak detector measures  $P = V_{PEAK}^2$  for all waveforms, while it should measure  $P = V_{PEAK}^2/2$  (for  $R = 1\Omega$ ) for a sine wave and  $P = V_{PEAK}^2/3$  for a triangle wave for instance. For a CDMA signal, the measurement error can be in the order of 5 to 6 dB. For many wave forms, specially those with high peak-to-average ratios, peak detection is not accurate enough and therefore a mean square detector is recommended.

### MEAN SQUARE CONFORMANCE ERROR

The LMV232 is a mean square detector and therefore should have an output voltage (in Volts) that linearly relates to the RF input power (in mW). The input referred error, with respect to an ideal linear mean square detector, is determined as a measure for the accuracy of the detector.



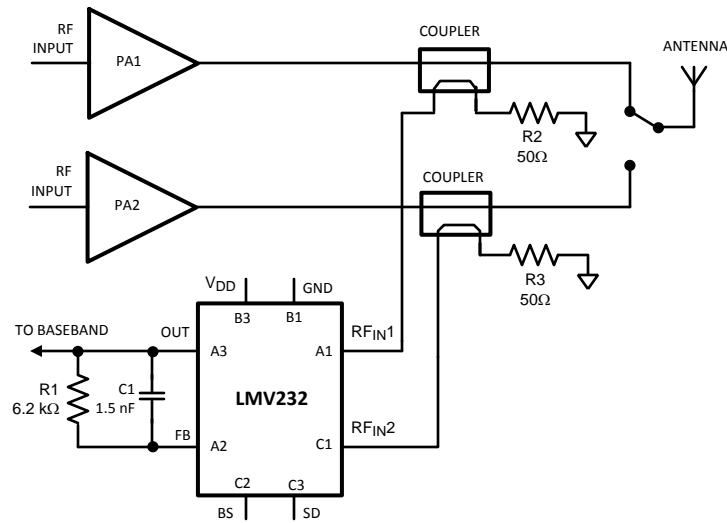

Figure 21. Typical Application

The detection curves of Figure 22 show the detector response to RF input power. To show the complete dynamic range on a logarithmic scale, the pedestal voltage ( $V_{PEDESTAL}$ ) is subtracted from the output. The pedestal voltage is defined as the output voltage in the absence of an RF input signal (at 25°C). The best-fit ideal mean square response is represented by the fitted curve in Figure 22. The input referred error of the detection curves with respect to this best-fit mean square response is determined as follows:

- Determine the best-fit mean square response.
- Determine the output referred error between the actual detector response and the ideal mean square response.
- Translate the output referred error to an input referred error.

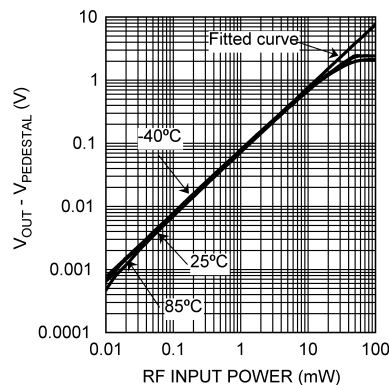

Figure 22. Detection Curve

The best-fit linear curve is obtained from the detector response by means of linear regression. The output referred error is calculated with the formula:

$$\text{Error}_{\text{dBV}} = 20 \cdot \log \left[ \frac{(V_{\text{OUT}} - V_{\text{PEDESTAL}})}{(K_{\text{DET}} \cdot P_{\text{IN}})} \right]$$

Where,

Conversion gain of the ideal fitted curve  $K_{\text{DET}}$  is in V/mW and the RF input power  $P_{\text{IN}}$  in mW.

To translate this output referred error (in dB) to an input referred error, it has to be divided by a factor of 2. This is due to the mean square characteristic of the device. The response of a mean square detector changes by 2 dB for every dB change of the input power. Figure 23 depicts the resulting curve.

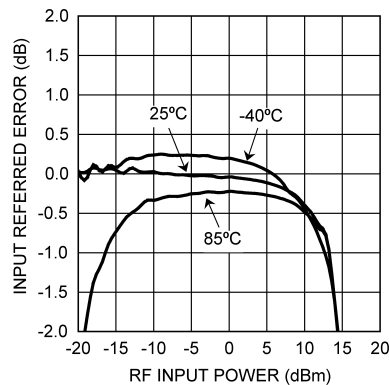

**Figure 23. Input referred Error vs. RF Input Power**

Analyzing [Figure 23](#) shows that three sections can be distinguished:

- At higher power levels the error increases.
- A middle section where the error is constant and relatively small.
- At lower power levels the error increases again.

These three sections are leading back to three error mechanisms. At higher power levels the detector output starts to saturate because the output voltage approaches the maximum signal swing that the detector can handle. The maximum output voltage of the device thus limits the upper end of the detection range. Also the maximum allowed ADC voltage of the baseband chip can limit the detection range at higher power levels. By adjusting the feedback resistor  $R_{FB}$  of [Figure 21](#) the upper end of the range can be shifted. This is valid until the detector cell inside the LMV232 is the limiting factor.

The middle section of the error curve shows a small error variation. This is the section where the detector is used and is called the detection range of the detector. This range is limited on both sides by a maximum allowed error.

For low input power levels, the variation of output voltage is very small. Therefore the measurement resolution ADC is important in order to measure those small variations. Offsets and temperature variation impact the accuracy at low power levels as well.

## DETECTION ERROR OVER TEMPERATURE

Like any power detector device, the output signal of the LMV232 mean square power detector shows some residual variation over temperature that limits its dynamic range. The variation determines the accuracy and range of input power levels for which the detector produces an accurate output signal.

The error over temperature is mainly caused by the variation of the pedestal voltage. Besides this, a minimal error contribution leads back to the conversion gain variation of the detector. This conversion gain error is visible in the mid-power range, where the temperature error curves of [Figure 23](#) run parallel to each other. Since the conversion gain variation is acceptable, the focus will be on the pedestal voltage variation over temperature.

The pedestal voltage at 25°C is subtracted from the output voltage of each curve. Variations of the pedestal voltage over temperature are thus included in the error.

The pedestal voltage variation itself consists of 2 error sources. One is the variation of the reference voltage  $V_{REF}$ . The other is an offset current  $I_{OS}$  that is generated inside the detector. This is depicted in [Figure 24](#). Depending on the measurement strategy one or both error sources can be eliminated.

The error sources of the pedestal voltage can be shown in a formula for  $V_{OUT}$ :

$$V_{OUT} = V_{REF} + (I_{OS} + I_{DET}) * R_{FB}$$

Where  $I_{DET}$  represents the intended detector output signal. In the absence of RF input power  $I_{DET}$  equals zero. The formula for the pedestal voltage can therefore be written as:

$$V_{PEDESTAL} = V_{REF} + I_{OS} * R_{FB}$$

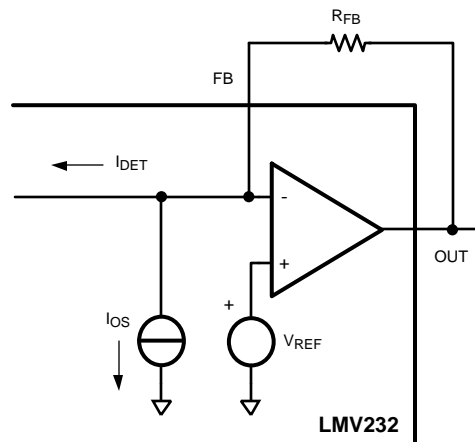

Figure 24. Pedestal Voltage

For low input power levels, the pedestal variation  $V_{PEDESTAL}$  is the dominant cause of error. Besides temperature variation of the pedestal voltage, which limits the lower end of the range, the pedestal voltage can also vary from part-to-part. By applying a suitable measurement strategy, the pedestal voltage error contribution can be significantly reduced or eliminated completely.

## POWER MEASUREMENT STRATEGIES

This section describes the measurement strategies to reduce or eliminate the pedestal voltage variation. Which strategy is chosen depends on the possibilities for a factory trim and implementation of calibration procedures.

Since the pedestal voltage is the reference level for the LMV232, it needs to be calibrated/measured at least once to eliminate part-to-part spread. This is required to determine the exact detector output signal. Because of process tolerances, the absolute part-to-part variation of the output voltage in the absence of RF input power will be in the order of 5 - 10%. All measurement strategies discussed eliminate this part-to-part spread.

### Strategy 1: Elimination of Part-to-Part Spread at Room Temperature Only

In this strategy, the pedestal voltage is determined once during manufacturing and stored into the memory of the phone. At each power measurement this stored pedestal level is digitally subtracted from the measured output signal of the LMV232 during normal operation. The procedure is thus:

- Measure the detector output in the absence of RF power during manufacturing.
- Store the output voltage value in the cell phone memory (after it is analog-to-digital converted).
- Subtract the stored value from each detector output reading.

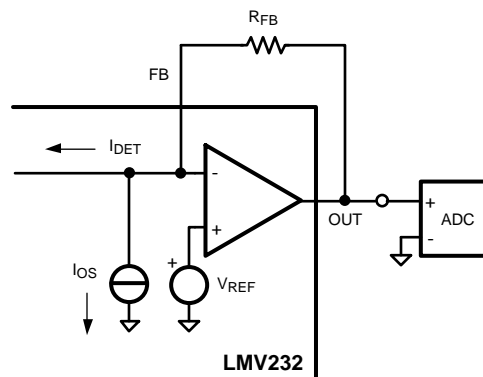
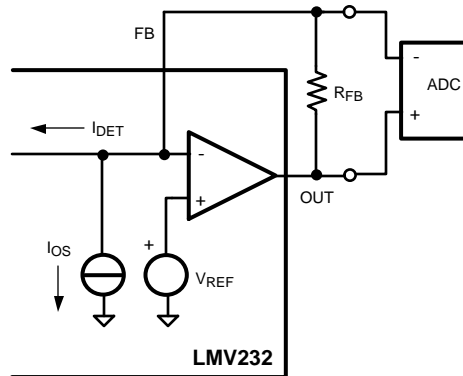

Figure 25. Strategy 1: Room Temperature Calibration

The advantage of this strategy is that calibration is required only once during manufacturing and not during normal operation. The disadvantage is the fact that this method neither compensates for the residual temperature drift of the reference voltage  $V_{REF}$  nor for offset current variations. Only part-to-part variations at room temperature are eliminated by this strategy. Especially the residual temperature drift negatively affects the measurement accuracy.

### Strategy 2: Elimination of Temperature Spread in $V_{REF}$

If software changes need to be reduced to a minimum and the baseband chip has a differential ADC, strategy 2 can be used to eliminate temperature variations of the reference voltage  $V_{REF}$ . One pin of the ADC is connected to FB and one is connected to OUT (Figure 26).



**Figure 26. Strategy 2: Differential Measurement**

The power measurement is independent of the reference voltage  $V_{REF}$ , since the ADC reading is:

$$V_{OUT} - V_{FB} = (I_{OS} + I_{DET}) * R_{FB}$$

The reading of the ADC obviously doesn't contain the reference voltage source  $V_{REF}$  anymore, but the contribution of the offset current remains present. This measurement is performed during normal operation. Therefore, it eliminates voltage reference variations over temperatures, as opposed to strategy 1. Also offset variations in the op amp are eliminated in this strategy.

### Strategy 3: Complete Elimination of Temperature Spread in Pedestal Voltage

The most accurate measurement is strategy 3, which eliminates the temperature variation of both the reference voltage  $V_{REF}$  and the offset current  $I_{OS}$ . In this strategy, the pedestal voltage is measured regularly during operation of the phone, and stored in the phone memory. For each power measurement, the stored value is digitally subtracted from the (analog-to-digital converted) detector output signal. Since it measures the pedestal voltage itself for calibration it compensates both for the reference voltage  $V_{REF}$  as well as for the offset current variation  $I_{OS}$ . The frequency of the 'calibration measurement' can be significantly lower than those of power measurements, depending on how fast the temperature of the device changes.

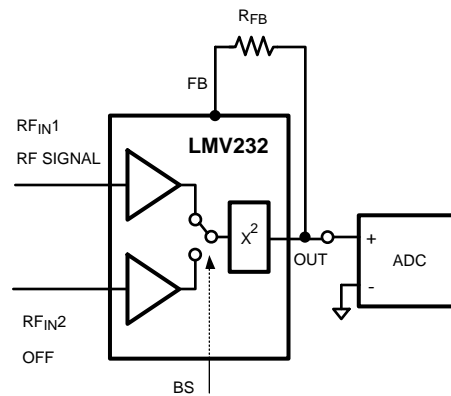

**Figure 27. Strategy 3: Calibration during normal operation**

The calibration measurement procedure can be explained with the aid of [Figure 21](#), which depicts a typical power measurement setup using the LMV232. In normal operation, the two PA's in the setup will never be active at the same time. One PA will produce the required transmit power, while the other one is off, (disabled) and produces no power. The pedestal voltage should be measured in the absence of RF power. This can be achieved by switching the Band Select (BS) pin such that the LMV232 input is selected where the disabled PA is connected to. The pedestal voltage at no input power can be read at the output pin.

Using the Band Select (BS) control pin of the LMV232:

- Select the RF input that is connected to the disabled PA, by the BS pin.
- Measure the detector output.
- Store the result in the phone memory.
- Subtract the stored value from each detector power reading, until a new update is performed.

Important advantages of this approach are that no factory trim is required and the temperature drift of the pedestal can be cancelled almost completely as well as the part-to-part spread. The remaining error is determined by the resolution of the ADC. A slight disadvantage is that on average more than one detector reading is required per power measurement. This overhead though can be made almost negligible in normal circumstances.

## REVISION HISTORY

Changes from Revision B (March 2013) to Revision C	Page
• Changed layout of National Data Sheet to TI format .....	13

**PACKAGING INFORMATION**

Orderable Device	Status (1)	Package Type	Package Drawing	Pins	Package Qty	Eco Plan (2)	Lead finish/ Ball material (6)	MSL Peak Temp (3)	Op Temp (°C)	Device Marking (4/5)	Samples
LMV232TL/NOPB	ACTIVE	DSBGA	YZR	8	250	RoHS & Green	SNAGCU	Level-1-260C-UNLIM	-40 to 85	A 02	<b>Samples</b>

(1) The marketing status values are defined as follows:

**ACTIVE:** Product device recommended for new designs.

**LIFEBUY:** TI has announced that the device will be discontinued, and a lifetime-buy period is in effect.

**NRND:** Not recommended for new designs. Device is in production to support existing customers, but TI does not recommend using this part in a new design.

**PREVIEW:** Device has been announced but is not in production. Samples may or may not be available.

**OBsolete:** TI has discontinued the production of the device.

(2) **RoHS:** TI defines "RoHS" to mean semiconductor products that are compliant with the current EU RoHS requirements for all 10 RoHS substances, including the requirement that RoHS substance do not exceed 0.1% by weight in homogeneous materials. Where designed to be soldered at high temperatures, "RoHS" products are suitable for use in specified lead-free processes. TI may reference these types of products as "Pb-Free".

**RoHS Exempt:** TI defines "RoHS Exempt" to mean products that contain lead but are compliant with EU RoHS pursuant to a specific EU RoHS exemption.

**Green:** TI defines "Green" to mean the content of Chlorine (Cl) and Bromine (Br) based flame retardants meet JS709B low halogen requirements of <=1000ppm threshold. Antimony trioxide based flame retardants must also meet the <=1000ppm threshold requirement.

(3) MSL, Peak Temp. - The Moisture Sensitivity Level rating according to the JEDEC industry standard classifications, and peak solder temperature.

(4) There may be additional marking, which relates to the logo, the lot trace code information, or the environmental category on the device.

(5) Multiple Device Markings will be inside parentheses. Only one Device Marking contained in parentheses and separated by a "~" will appear on a device. If a line is indented then it is a continuation of the previous line and the two combined represent the entire Device Marking for that device.

(6) Lead finish/Ball material - Orderable Devices may have multiple material finish options. Finish options are separated by a vertical ruled line. Lead finish/Ball material values may wrap to two lines if the finish value exceeds the maximum column width.

**Important Information and Disclaimer:**The information provided on this page represents TI's knowledge and belief as of the date that it is provided. TI bases its knowledge and belief on information provided by third parties, and makes no representation or warranty as to the accuracy of such information. Efforts are underway to better integrate information from third parties. TI has taken and continues to take reasonable steps to provide representative and accurate information but may not have conducted destructive testing or chemical analysis on incoming materials and chemicals. TI and TI suppliers consider certain information to be proprietary, and thus CAS numbers and other limited information may not be available for release.

In no event shall TI's liability arising out of such information exceed the total purchase price of the TI part(s) at issue in this document sold by TI to Customer on an annual basis.

**TAPE AND REEL INFORMATION**

**QUADRANT ASSIGNMENTS FOR PIN 1 ORIENTATION IN TAPE**

\*All dimensions are nominal

Device	Package Type	Package Drawing	Pins	SPQ	Reel Diameter (mm)	Reel Width W1 (mm)	A0 (mm)	B0 (mm)	K0 (mm)	P1 (mm)	W (mm)	Pin1 Quadrant
LMV232TL/NOPB	DSBGA	YZR	8	250	178.0	8.4	1.7	1.7	0.76	4.0	8.0	Q1



**TAPE AND REEL BOX DIMENSIONS**

\*All dimensions are nominal

Device	Package Type	Package Drawing	Pins	SPQ	Length (mm)	Width (mm)	Height (mm)
LMV232TL/NOPB	DSBGA	YZR	8	250	208.0	191.0	35.0

YZR0008

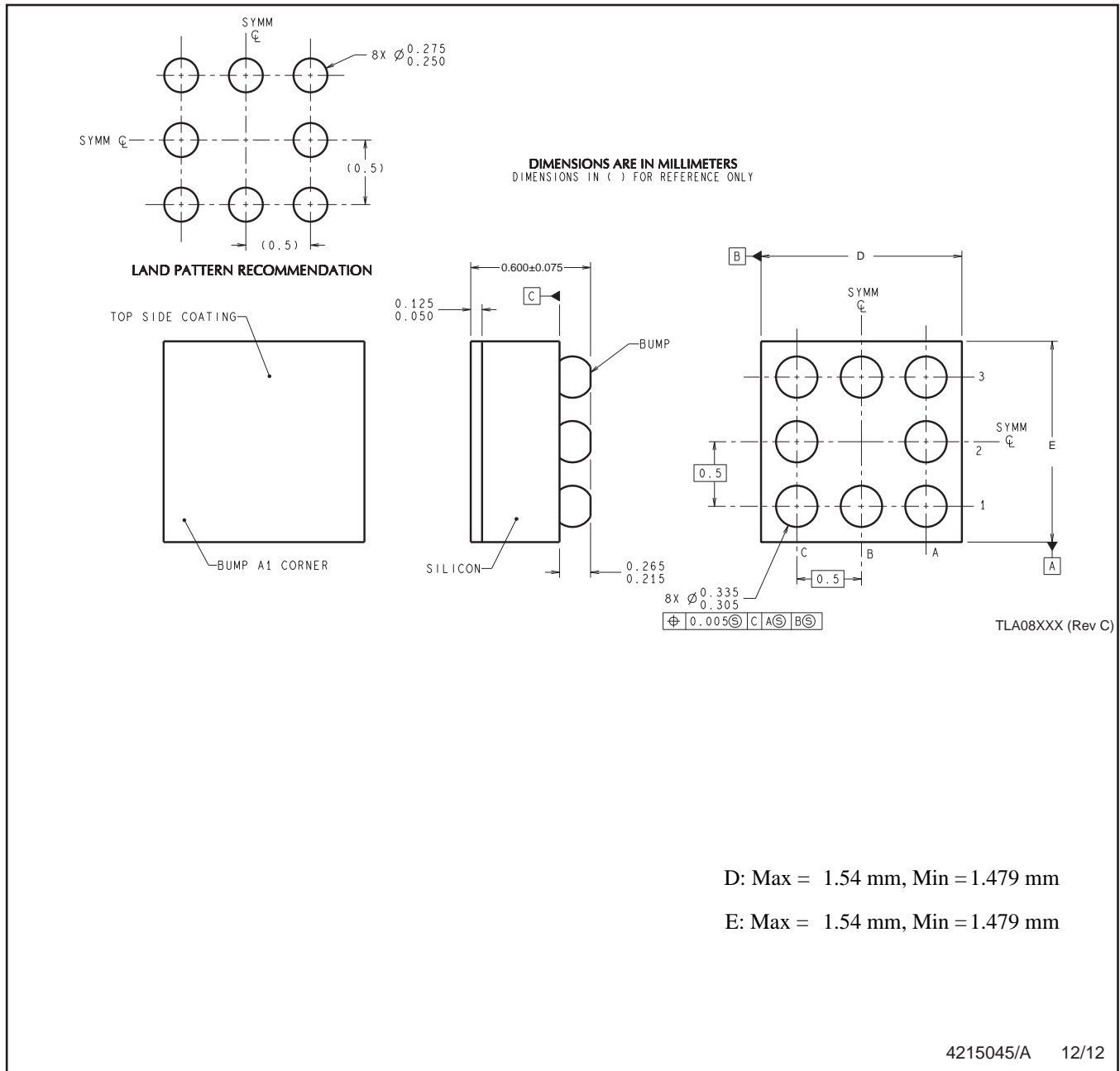

NOTES: A. All linear dimensions are in millimeters. Dimensioning and tolerancing per ASME Y14.5M-1994.  
B. This drawing is subject to change without notice.

## IMPORTANT NOTICE AND DISCLAIMER

TI PROVIDES TECHNICAL AND RELIABILITY DATA (INCLUDING DATA SHEETS), DESIGN RESOURCES (INCLUDING REFERENCE DESIGNS), APPLICATION OR OTHER DESIGN ADVICE, WEB TOOLS, SAFETY INFORMATION, AND OTHER RESOURCES "AS IS" AND WITH ALL FAULTS, AND DISCLAIMS ALL WARRANTIES, EXPRESS AND IMPLIED, INCLUDING WITHOUT LIMITATION ANY IMPLIED WARRANTIES OF MERCHANTABILITY, FITNESS FOR A PARTICULAR PURPOSE OR NON-INFRINGEMENT OF THIRD PARTY INTELLECTUAL PROPERTY RIGHTS.

These resources are intended for skilled developers designing with TI products. You are solely responsible for (1) selecting the appropriate TI products for your application, (2) designing, validating and testing your application, and (3) ensuring your application meets applicable standards, and any other safety, security, regulatory or other requirements.

These resources are subject to change without notice. TI grants you permission to use these resources only for development of an application that uses the TI products described in the resource. Other reproduction and display of these resources is prohibited. No license is granted to any other TI intellectual property right or to any third party intellectual property right. TI disclaims responsibility for, and you will fully indemnify TI and its representatives against, any claims, damages, costs, losses, and liabilities arising out of your use of these resources.

TI's products are provided subject to [TI's Terms of Sale](#) or other applicable terms available either on [ti.com](http://ti.com) or provided in conjunction with such TI products. TI's provision of these resources does not expand or otherwise alter TI's applicable warranties or warranty disclaimers for TI products.

TI objects to and rejects any additional or different terms you may have proposed.

Mailing Address: Texas Instruments, Post Office Box 655303, Dallas, Texas 75265  
Copyright © 2022, Texas Instruments Incorporated