

USB Keyboard Using MSP430™ Microcontrollers

David Racine, Luis Reynoso

MSP430 Apps

ABSTRACT

This application report describes a low-cost highly-flexible composite USB keyboard implementation based on MSP430F5xx/MSP430F6xx families. Schematics and software are included allowing for an easy implementation and customization.

The document explains basic necessary concepts but familiarity with the MSP430™ USB Developers Package ([MSP430USBDEVPACK](#)) and USB HID specification is assumed.

Source code and additional information described in this application report can be downloaded from http://software-dl.ti.com/msp430/msp430_public_sw/mcu/msp430/USBKBD_430/latest/index_FDS.html.

Contents

1	Introduction	2
2	Implementation	2
3	Software.....	6
4	Hardware and Peripheral Usage	12
5	Using the USB Keyboard.....	12
6	Schematics	15
7	References	16

List of Figures

1	Key Matrix	3
2	Keyboard Schematic	3
3	Detection of a Key Using Column-Interrupt Method	4
4	Detection of a Key Using Polling Method.....	4
5	"Ghost" Key Detection	5
6	USB Keyboard Software Modules.....	6
7	USB Keyboard Flow Diagram.....	7
8	Digital Keyscan Flow Diagram	9
9	USB Keyboard in Windows Device Manager.....	13
10	Testing the HID Custom Interface	14
11	Schematics	15

List of Tables

1	VID/PID Used by the Device	5
2	HID Keyboard Report Format	8
3	Communication Protocol Report Descriptor.....	8
4	Implemented Protocol	8
5	Configuration Constant Table	11
6	ScanCodes	11
7	MSP430F550x/5510 Peripheral Usage	12
8	MSP430F550x/5510 Pinout Usage	12

Trademarks

MSP430, Code Composer Studio are trademarks of Texas Instruments.
IAR Embedded Workbench is a trademark of IAR Systems.

1 Introduction

This application report describes the implementation of a USB keyboard with the following characteristics:

- 101 keys, 2 LEDs: standard HID keyboard and LED usage
- 16x8 matrix: allows for easy customization of different keyboard layouts
- Composite USB device: In addition to the keyboard interface, it includes an HID-datapipe back-channel which can be used to transmit any custom data
- HID boot protocol support, allowing keyboard to be used to interface with a PC's BIOS
- "Ghost" key handling in software, to prevent errors from multiple key presses
- Uses MSP430F550x/5510 low-cost USB family

The Texas Instruments MSP430F550x/5510 devices are ultra-low power microcontrollers featuring a powerful 16-bit RISC CPU, 16-bit registers, and constant generators that contribute to maximum code efficiency. In addition, this MSP430 family includes an integrated USB and PHY supporting USB 2.0 full-speed communication, four 16-bit timers, a high-performance 10-bit analog-to-digital converter (ADC), two universal serial communication interfaces (USCI), hardware multiplier, DMA, real-time clock module with alarm capabilities, and 31 or 47 I/O pins.

2 Implementation

2.1 Key Matrix

The USB keyboard presented in this application report implements a key matrix of rows and columns similar to smaller keypads like the one shown in the application report *Implementing An Ultralow-Power Keypad Interface with MSP430* ([SLAA139](#)).

This implementation uses a 16 rows x 8 columns matrix, which allows up to 128 keys, but it actually uses only 101 keys in total.

The key matrix is shown in [Figure 1](#).

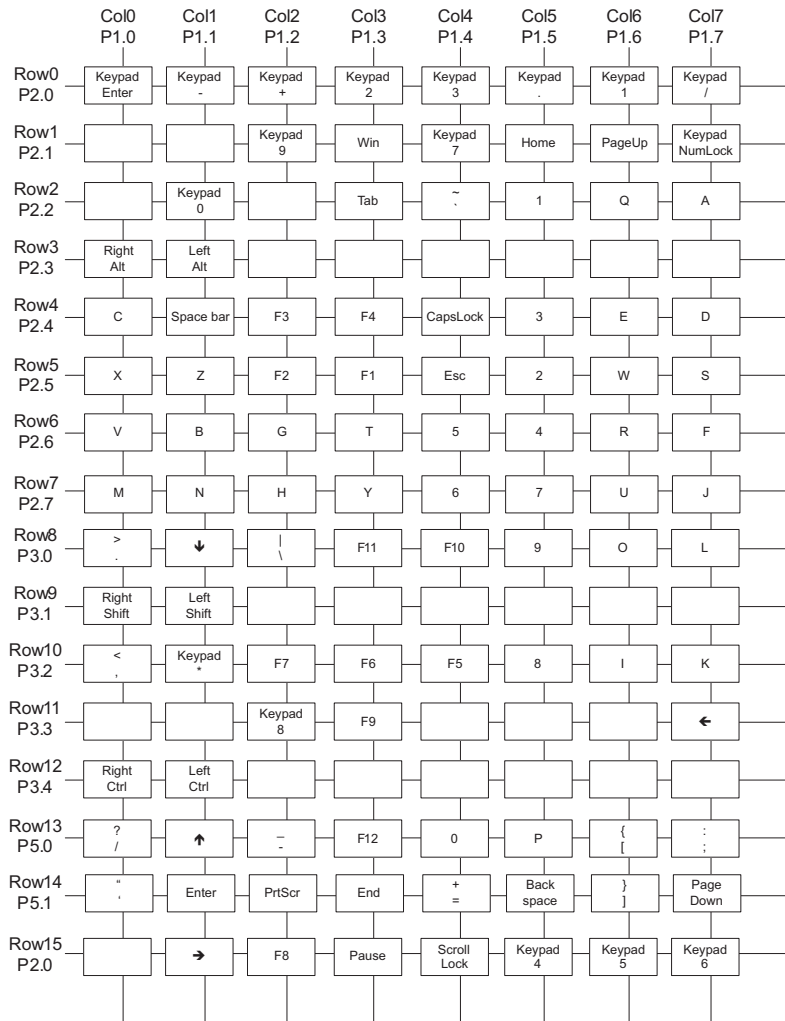

Figure 1. Key Matrix

Each key works like a switch, and pulldowns are implemented on each column, keeping the idle state low (see Figure 2).

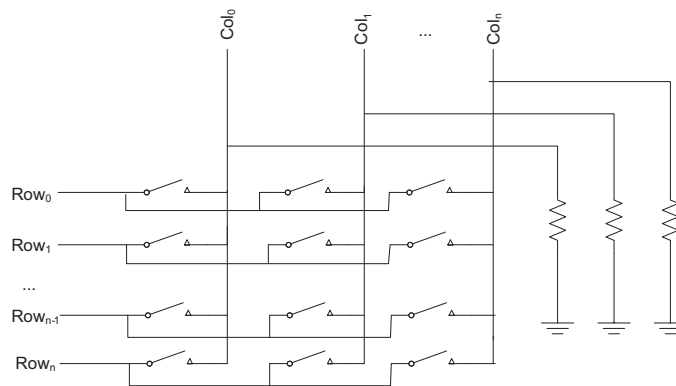

Figure 2. Keyboard Schematic

There are multiple ways to scan a key matrix, but this application report uses two methods, referred in this application report as: column-interrupt and polling.

In the column-interrupt approach, all rows are actively driven at the same time and columns are configured to interrupt the processor when any single key is pressed.

This method is useful in low-power modes, because any key can wake up the microcontroller; however, it is important to remark that the key press is only used for that purpose, because it does not provide the exact key being pressed.

Figure 3 shows the key matrix behavior when the Enter key is pressed in column-interrupt mode. Actively driven rows and columns are shown in red. Notice that the Col1 pin would detect a change when the Enter key is pressed, but the effect would be the same for any other pin pressed in the same column.

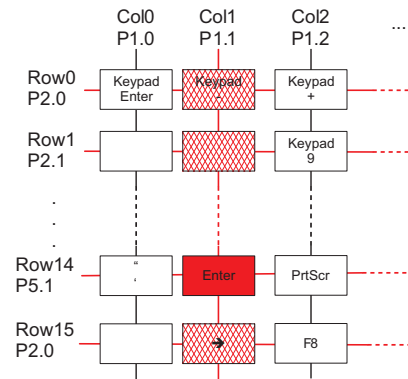

Figure 3. Detection of a Key Using Column-Interrupt Method

After the system is awake due to a key press using the column-interrupt approach, the polling method can be used to determine which key(s) is(are) being pressed (see Figure 4). In the polling method, each row is scanned separately driving one row at a time in sequential order. The columns are then read giving the exact keys being pressed.

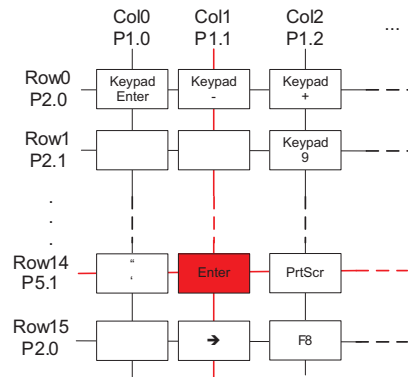

Figure 4. Detection of a Key Using Polling Method

One of the caveats when using this method is that particular patterns can cause unwanted connections, known as "ghost" keys. This behavior is caused when three or more keys sharing rows and columns are pressed at the same time (see Figure 5).

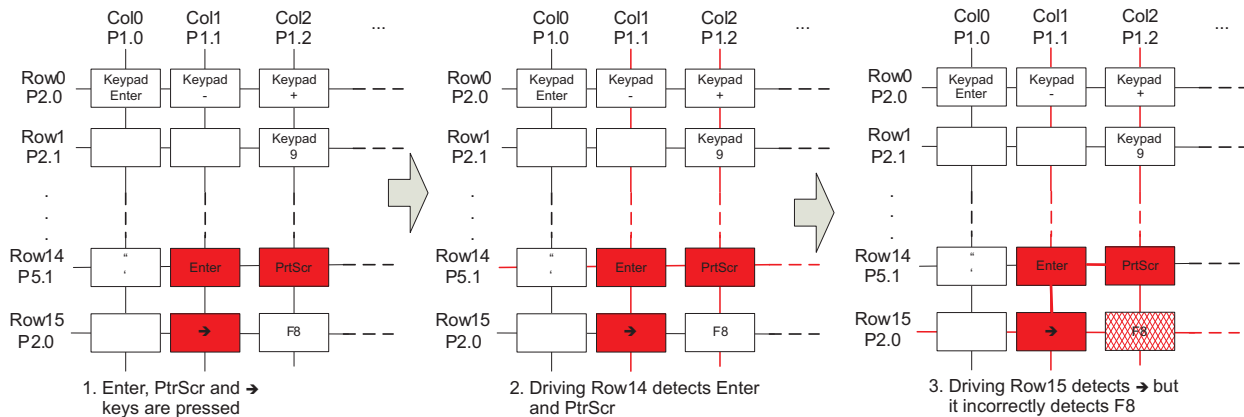

Figure 5. "Ghost" Key Detection

The software included in this application report detects potential "ghost" keys and does not report them to the host.

2.2 USB HID

This application report uses the MSP430 application programming interface (API) stack found in the MSP430 USB Developers Package ([MSP430USBDEVPACK](#)).

The stack is configured to work as a composite HID-HID interface with the first interface being a standard Keyboard and the second interface used as a DataPipe. One of the advantages of using this implementation, which uses only HID interfaces, is that no drivers are required.

Although the relevant code for the keyboard implementation uses the standard keyboard interface, the DataPipe interface was added to provide users with more flexibility and to facilitate customization.

This interface can be used to send or receive any type of data to/from the host, so that the MSP430 microcontroller not only performs the job of a digital keyboard, but it can also be used to perform other jobs taking advantage of the same USB interface and the rest of the peripherals. Some examples include reading sensors using ADC and reporting to PC, controlling actuators using timer PWMs, etc.

It should be noted that while the host OS interprets and uses the data from the standard keyboard interface without additional applications or drivers, in the case of the Datapipe interface, a host application is required. Texas Instruments provides an HID API which enables communication between a PC and a MSP430 microcontroller running the HID API stack. This HID API is available in executable format and source code in the MSP430 USB Developers Package ([MSP430USBDEVPACK](#)).

The keyboard interface supports Boot protocol, which allows it to work with HID-limited hosts (such as some BIOS).

VID and PID can be modified according to the particular application but the default code used for this example uses the values shown in [Table 1](#).

Table 1. VID/PID Used by the Device

VID	0x2047
PID	0x0401

3 Software

3.1 Tools

The software included in this application report was built and tested using:

- IAR Embedded Workbench™ for MSP430 5.30.4 IDE
- Code Composer Studio™ (CCS) 5.1.0 IDE

3.2 Software Implementation

Figure 6 shows the software layers for the USB keyboard.

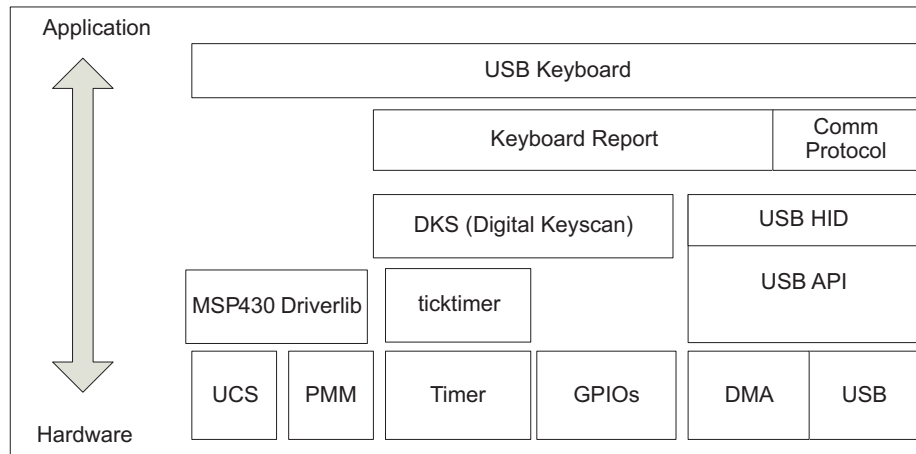

Figure 6. USB Keyboard Software Modules

Software is designed in a modular way, re-using existing TI libraries such as driverlib and the USB API and adding new modules from low-level drivers to application level. These modules include:

- **USB Keyboard**

Description

Main application initializing the microcontroller, peripherals, and executing a loop checking and servicing the rest of the modules.

Files

Src\TI_USBKBD_main.c

Flow Diagram

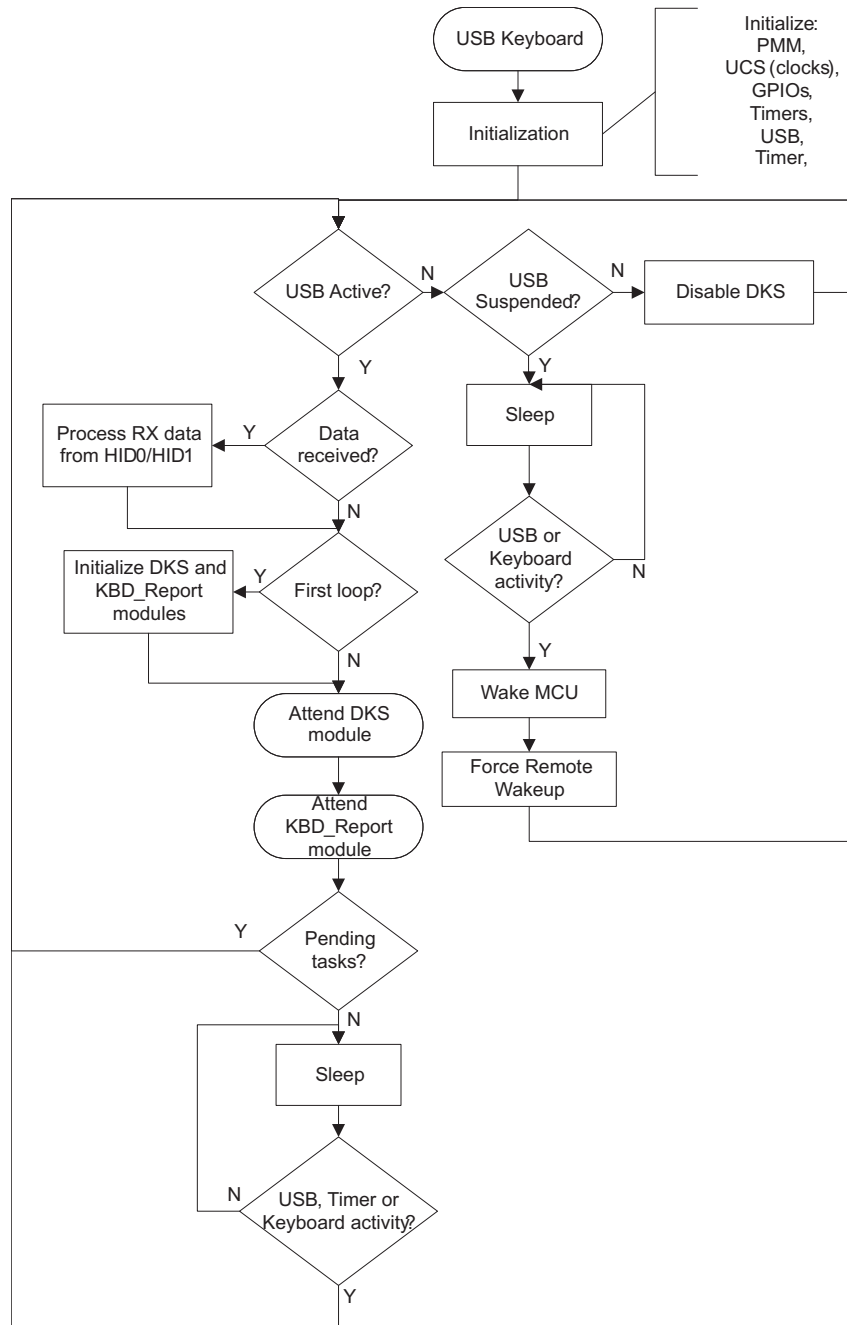

Figure 7. USB Keyboard Flow Diagram

- **Keyboard Report**

Description

Handles the HID Keyboard report, adding and removing keys from the report depending on press/release events and sends the report to the USB Host.

Files

Src\TI_USBKBD_HIDKBD_report.c

Src\Include\TI_USBKBD_HIDKBD_report_public.h

HID Keyboard Report Format

Table 2. HID Keyboard Report Format

	Bit7	Bit6	Bit5	Bit4	Bit3	Bit2	Bit1	Bit0
Byte0	Right GUI	Right Alt	Right Shift	Right Ctrl	Left GUI	Left Alt	Left Shift	Left Ctrl
Byte1	Reserved							
Byte2	Key_array[0]							
Byte3	Key_array[1]							
Byte4	Key_array[2]							
Byte5	Key_array[3]							
Byte6	Key_array[4]							
Byte7	Key_array[5]							

- **Communication Protocol**

Description

Handles the HID custom interface, which is used to transfer data to/from an USB host. The current implementation shows a template that can be used for custom development.

This module uses the HID-Datapipe as defined in the USB API included in MSP430 USB Developers Package ([MSP430USBDEVPACK](#)).

Files

Src\TI_USBKBD_comm_protocol.c

Src\Include\TI_USBKBD_comm_protocol_public.h

HID Custom Interface Report Descriptor

Table 3. Communication Protocol Report Descriptor

Field	Size	Description
IN Report		
Report ID	1 byte	The report ID of the chosen report (automatically assigned to 0x3F by the HID-Datapipe calls)
Size	1 byte	The number of valid bytes in the data field
Data	62 bytes	Data payload
OUT Report		
Report ID	1 byte	The report ID of the chosen report (must be assigned to 0x3F by the host)
Size	1 byte	The number of valid bytes in the data field
Data	62 bytes	Data payload

Data Payload Protocol

Table 4. Implemented Protocol

Field	Size	Description
CMD	1 byte	1 = Toggle CAPS LED 2 = Toggle NUM LED
Data	61 bytes	Unused

• **DKS (Digital KeyScan)**

Description

Handles the digital keyboard scanning, detecting key press/release events, and reporting them to the keyboard report module.

Files

Src\TI_USBKBD_DKS.c

Src\Include\TI_USBKBD_DKS_public.h

Flow Diagram

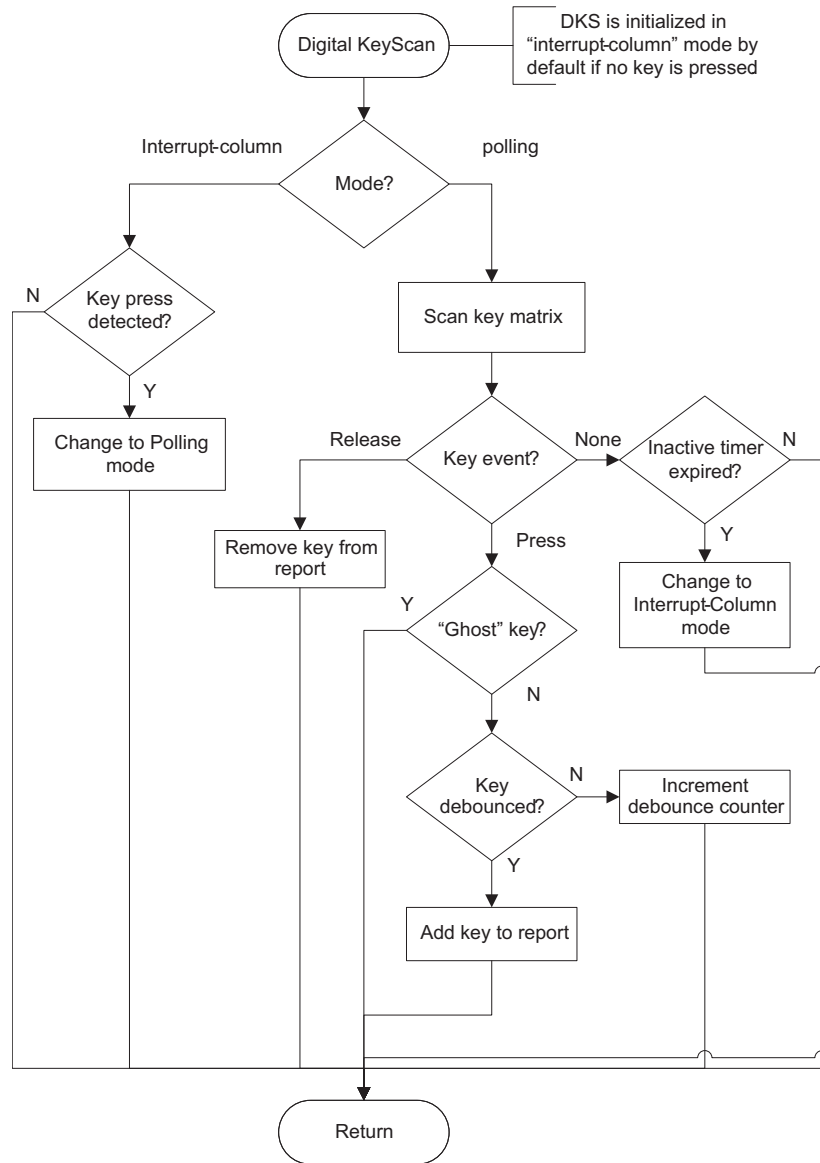

Figure 8. Digital KeyScan Flow Diagram

- **USB API / USB HID**

Description

The MSP430 USB API stack is a software solution provided by Texas Instruments that includes support for:

- Communications Device Class (CDC)
- Human Interface Device class (HID)
- Mass Storage Class (MSC)
- Personal HealthCare Device Class (PHDC)

This software solution, including detailed documentation, is available in the MSP430 USB Developers Package ([MSP430USBDEVPACK](#)).

Files

Src\USB_API*.*

Src\USB_config*.*

Src\USB_App*.*

- **Ticktimer**

Description

Handles a general purpose interrupt timer that is used as a timebase, to wake-up the processor, and to trigger a new keyboard scan, among other functions.

The ticktimer is implemented using TA0.0 with a default time base of 2 ms.

Files

Src\TI_USBKBD_ticktimer.c

Src\Include\TI_USBKBD_ticktimer_public.h

- **MSP430 Driverlib**

Description

The Texas Instruments MSP430 Peripheral Driver Library (Driverlib) is a set of drivers that provide an easy mechanism to use the MSP430 peripherals. This software uses Driverlib to initialize the PMM and UCS modules.

Source code and detailed documentation are available in MSP430Ware (www.ti.com/msp430ware). For simplicity purposes, this project includes only the pre-compiled libraries for IAR and CCS using a small memory model and header files.

Files

Src\ driverlib*.*

Src\ driverlib\driverlib_small_CCS.lib

Src\ driverlib\driverlib_small_IAR.r43

3.3 Configuration and ScanCode Tables

For modularity purposes and to allow for an easier optimization or upgrade, the USB keyboard software reserves some Flash sectors for constant tables that define some of the functionality of the application and define the ScanCode table.

- **Configuration Constant Table**

Description

Contains the USB keyboard version and configuration constants defining the KeyScan functionality, such as debounce counter, ticktimer period, etc.

Files

Src\TI_USBKBD_SharedTables.c (declaration)

Src\Include\TI_USBKBD_public.h (typedef)

Declaration

```
const USBKBD_config_const_t USBKBD_configconst_s
```

Location

USBKBD_CONFIGCONST_SEGMENT (0xFC00-0xFDFF)

Contents
Table 5. Configuration Constant Table

Field	Size	Description
MagicKey	4 bytes	Indicates the start of the table. 0xDEADC0DE is used by default.
Version	2 bytes	USB keyboard version in BCD format: 0x0101 - 1.0.1
ticktimer_div	2 bytes	TickTimer divider (based on ACLK): 66 represents a period of 66 / 32768 = ~2 ms
debounce_cycles	2 bytes	Number of debounce cycles in tick counts: 2 represents a debounce of 4 ms with Ticktimer = 2 ms
inactive_timeout	2 bytes	Number of tick counts before going to interrupt_column mode if no key is detected: 8 represents 16 ms with Ticktimer = 2 ms

- **ScanCode Table**

Description

Contains the USB Keyboard scancode table, mapping each row and column to the corresponding value based on HID Usage Tables.

Files

Src\TI_USBKBD_SharedTables.c(declaration)

Src\Include\TI_USBKBD_public.h(tyedef)

Declaration

```
const USBKBD_scancode_t USBKBD_scancodes_s
```

Location

USBKBD_SCANCODES_SEGMENT (0xFA00-0xFBFF)

Contents
Table 6. ScanCodes

Field	Size	Description
MagicKey	4 bytes	Indicates the start of the table. 0xDEADC0DE is used by default.
keycode	128 bytes	Keycodes for each key in the following order: Row0,Col0 Row0,Col1 ... Row0,Col7 Row1,Col0 Row1,Col1 ... Row15,Col6 Row15,Col7

4 Hardware and Peripheral Usage

In addition to system modules (UCS, PMM), this keyboard implementation uses the peripherals shown in [Table 7](#).

Table 7. MSP430F550x/5510 Peripheral Usage

Peripheral	Usage
USB	Communication with host (Composite HID-HID)
Timer_A0 (TA0.0)	TimerTick used as a time base to perform periodic polling, debounce, etc.

In addition to the circuitry required for USB and common functionality (reset, VCC, VSS, crystal, etc.), the USB keyboard uses the pins shown in [Table 8](#).

Table 8. MSP430F550x/5510 Pinout Usage

Columns	KSO0	P2.0	Rows	KSI0	P1.0
	KSO1	P2.1		KSI1	P1.1
	KSO2	P2.2		KSI2	P1.2
	KSO3	P2.3		KSI3	P1.3
	KSO4	P2.4		KSI4	P1.4
	KSO5	P2.5		KSI5	P1.5
	KSO6	P2.6		KSI6	P1.6
	KSO7	P2.7		KSI7	P1.7
	KSO8	P3.0	LEDs	LED0 (CAPS)	P4.7
	KSO9	P3.1		LED1 (NUM)	P4.6
	KSO10	P3.2			
	KSO11	P3.3			
	KSO12	P3.4			
	KSO13	P5.0			
	KSO14	P5.1			
KSO15	P5.4				

Schematics showing the implementation on the USB keyboard are found in [Section 6](#).

5 Using the USB Keyboard

When connected to a PC, the USB keyboard should be detected by the operating system and enumerated without drivers. Windows shows three devices in the Device Manager (see [Figure 9](#)).

- Human Interface Devices
 - USB Human Interface Device: Standard keyboard in intf0 (MI_00)
 - USB Human Interface Device: Custom interface in intf1 (MI_01)
- Keyboards
 - HID Keyboard Device: Standard keyboard in intf0 (MI_00)

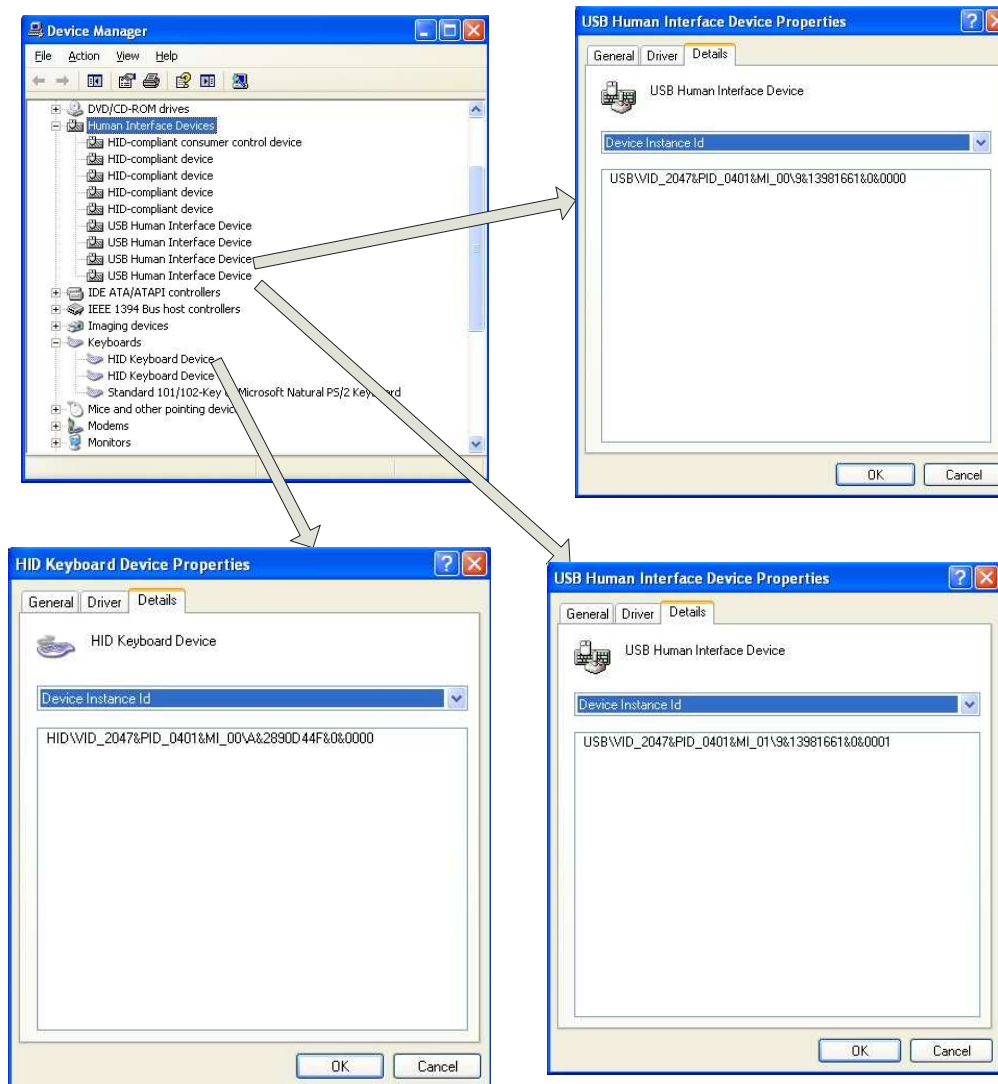

Figure 9. USB Keyboard in Windows Device Manager

The keyboard can now be tested and used as a standard keyboard.

In addition to the regular key functionality, the custom interface can be tested using the MSP430 HID USB Application following these steps (see [Figure 10](#)):

1. Select the VID and PID (default: VID = 0x2047, PID = 0x0401).
2. Click Set VID PID.
3. Click Connect.
4. The LED should turn green.
5. Write one of the commands in the Send & Receive field.
6. Observe the response from the USB keyboard.

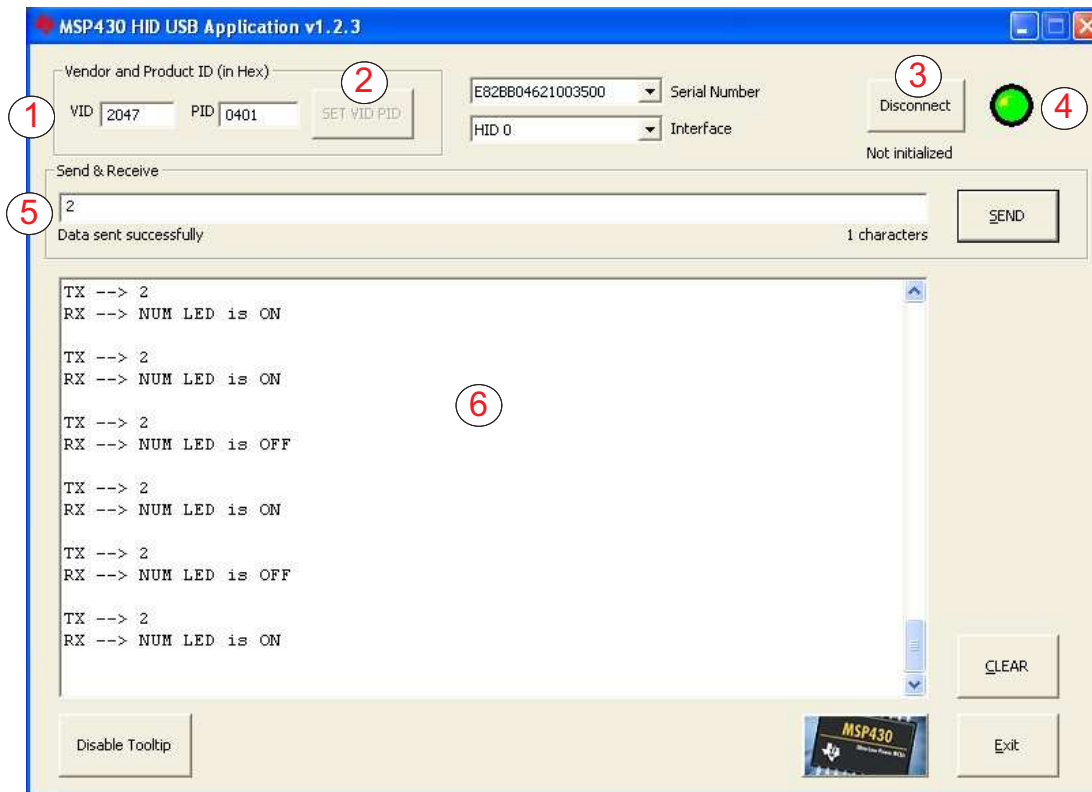

Figure 10. Testing the HID Custom Interface

The MSP430 HID USB Application is available in the MSP430 USB Developers Package ([MSP430USBDEVPACK](#)).

5.1 Performance

The usual response time for keyboards is approximately 5 to 50 ms. While this depends on different factors such as the mechanical implementation of the keyboard, USB bus load, etc., by using this software, developers have more flexibility to customize the application according to their needs. Whether response time, price, or power consumption is the most important requirement, parameters such as debounce time, polling scan rate, USB polling interval, and microcontroller internal frequency can be adjusted to meet particular requirements.

One important factor affecting the response time is the polling rate, which defines the time required to scan all keys. While a key press is detected in a few cycles in column-interrupt mode, the algorithm to recognize the particular pressed key, debounce it, discard "ghost" keys, etc. can take more cycles.

During bench tests, this implementation was measured to take ~1870 cycles (which is equivalent to ~233 μs at 8 MHz) for the first pressed key and ~520 cycles (~65 μs at 8 MHz) for each additional pressed key.

5.2 Memory Footprint

The following memory footprint was obtained using IAR Embedded Workbench 5.30.4 using the maximum optimization level:

- Code: 7626 Bytes
- Constants: 1096 Bytes
- Data: 679 Bytes

6 Schematics

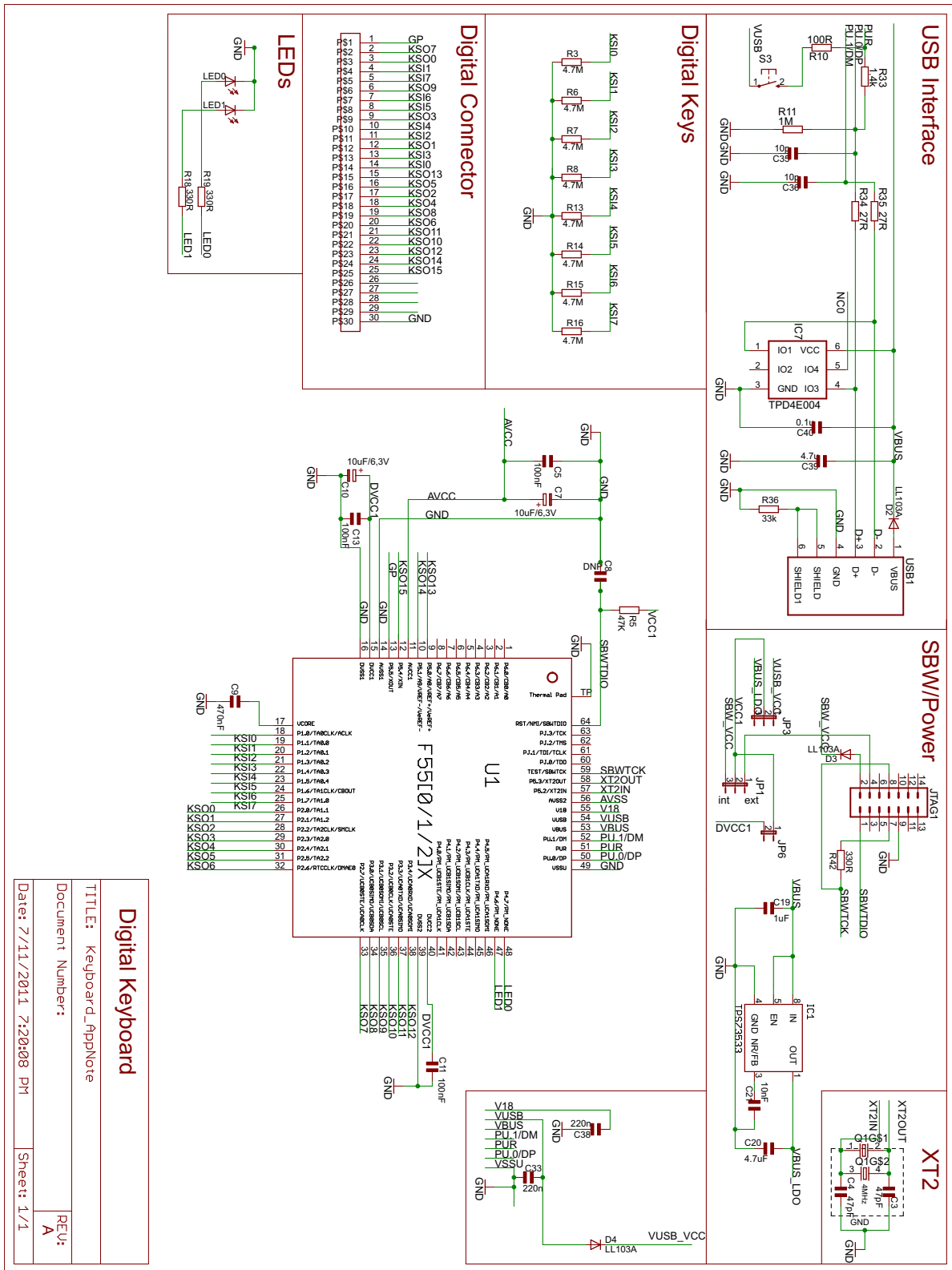

Figure 11. Schematics

7 References

1. [USB HID specification](#)
2. [MSP430F5xx and MSP430F6xx Family User's Guide](#)
3. [MSP430F550x, MSP430F5510 Mixed-Signal Microcontrollers](#)
4. [MSP430 USB Developers Package \(MSP430USBDEVPACK\)](#)
5. [MSP430Ware](#)
6. [Implementing An Ultra-Low-Power Keypad Interface With MSP430 MCUs](#)

IMPORTANT NOTICE FOR TI DESIGN INFORMATION AND RESOURCES

Texas Instruments Incorporated ("TI") technical, application or other design advice, services or information, including, but not limited to, reference designs and materials relating to evaluation modules, (collectively, "TI Resources") are intended to assist designers who are developing applications that incorporate TI products; by downloading, accessing or using any particular TI Resource in any way, you (individually or, if you are acting on behalf of a company, your company) agree to use it solely for this purpose and subject to the terms of this Notice.

TI's provision of TI Resources does not expand or otherwise alter TI's applicable published warranties or warranty disclaimers for TI products, and no additional obligations or liabilities arise from TI providing such TI Resources. TI reserves the right to make corrections, enhancements, improvements and other changes to its TI Resources.

You understand and agree that you remain responsible for using your independent analysis, evaluation and judgment in designing your applications and that you have full and exclusive responsibility to assure the safety of your applications and compliance of your applications (and of all TI products used in or for your applications) with all applicable regulations, laws and other applicable requirements. You represent that, with respect to your applications, you have all the necessary expertise to create and implement safeguards that (1) anticipate dangerous consequences of failures, (2) monitor failures and their consequences, and (3) lessen the likelihood of failures that might cause harm and take appropriate actions. You agree that prior to using or distributing any applications that include TI products, you will thoroughly test such applications and the functionality of such TI products as used in such applications. TI has not conducted any testing other than that specifically described in the published documentation for a particular TI Resource.

You are authorized to use, copy and modify any individual TI Resource only in connection with the development of applications that include the TI product(s) identified in such TI Resource. NO OTHER LICENSE, EXPRESS OR IMPLIED, BY ESTOPPEL OR OTHERWISE TO ANY OTHER TI INTELLECTUAL PROPERTY RIGHT, AND NO LICENSE TO ANY TECHNOLOGY OR INTELLECTUAL PROPERTY RIGHT OF TI OR ANY THIRD PARTY IS GRANTED HEREIN, including but not limited to any patent right, copyright, mask work right, or other intellectual property right relating to any combination, machine, or process in which TI products or services are used. Information regarding or referencing third-party products or services does not constitute a license to use such products or services, or a warranty or endorsement thereof. Use of TI Resources may require a license from a third party under the patents or other intellectual property of the third party, or a license from TI under the patents or other intellectual property of TI.

TI RESOURCES ARE PROVIDED "AS IS" AND WITH ALL FAULTS. TI DISCLAIMS ALL OTHER WARRANTIES OR REPRESENTATIONS, EXPRESS OR IMPLIED, REGARDING TI RESOURCES OR USE THEREOF, INCLUDING BUT NOT LIMITED TO ACCURACY OR COMPLETENESS, TITLE, ANY EPIDEMIC FAILURE WARRANTY AND ANY IMPLIED WARRANTIES OF MERCHANTABILITY, FITNESS FOR A PARTICULAR PURPOSE, AND NON-INFRINGEMENT OF ANY THIRD PARTY INTELLECTUAL PROPERTY RIGHTS.

TI SHALL NOT BE LIABLE FOR AND SHALL NOT DEFEND OR INDEMNIFY YOU AGAINST ANY CLAIM, INCLUDING BUT NOT LIMITED TO ANY INFRINGEMENT CLAIM THAT RELATES TO OR IS BASED ON ANY COMBINATION OF PRODUCTS EVEN IF DESCRIBED IN TI RESOURCES OR OTHERWISE. IN NO EVENT SHALL TI BE LIABLE FOR ANY ACTUAL, DIRECT, SPECIAL, COLLATERAL, INDIRECT, PUNITIVE, INCIDENTAL, CONSEQUENTIAL OR EXEMPLARY DAMAGES IN CONNECTION WITH OR ARISING OUT OF TI RESOURCES OR USE THEREOF, AND REGARDLESS OF WHETHER TI HAS BEEN ADVISED OF THE POSSIBILITY OF SUCH DAMAGES.

You agree to fully indemnify TI and its representatives against any damages, costs, losses, and/or liabilities arising out of your non-compliance with the terms and provisions of this Notice.

This Notice applies to TI Resources. Additional terms apply to the use and purchase of certain types of materials, TI products and services. These include; without limitation, TI's standard terms for semiconductor products (<http://www.ti.com/sc/docs/stdterms.htm>), [evaluation modules](#), and [samples](http://www.ti.com/sc/docs/sampterm.htm) (<http://www.ti.com/sc/docs/sampterm.htm>).

Mailing Address: Texas Instruments, Post Office Box 655303, Dallas, Texas 75265
Copyright © 2018, Texas Instruments Incorporated