

***Bus-Interface Devices
With Output-Damping Resistors
or Reduced-Drive Outputs***

SCBA012A
August 1997



IMPORTANT NOTICE

Texas Instruments (TI) reserves the right to make changes to its products or to discontinue any semiconductor product or service without notice, and advises its customers to obtain the latest version of relevant information to verify, before placing orders, that the information being relied on is current.

TI warrants performance of its semiconductor products and related software to the specifications applicable at the time of sale in accordance with TI's standard warranty. Testing and other quality control techniques are utilized to the extent TI deems necessary to support this warranty. Specific testing of all parameters of each device is not necessarily performed, except those mandated by government requirements.

Certain applications using semiconductor products may involve potential risks of death, personal injury, or severe property or environmental damage ("Critical Applications").

TI SEMICONDUCTOR PRODUCTS ARE NOT DESIGNED, INTENDED, AUTHORIZED, OR WARRANTED TO BE SUITABLE FOR USE IN LIFE-SUPPORT APPLICATIONS, DEVICES OR SYSTEMS OR OTHER CRITICAL APPLICATIONS.

Inclusion of TI products in such applications is understood to be fully at the risk of the customer. Use of TI products in such applications requires the written approval of an appropriate TI officer. Questions concerning potential risk applications should be directed to TI through a local SC sales office.

In order to minimize risks associated with the customer's applications, adequate design and operating safeguards should be provided by the customer to minimize inherent or procedural hazards.

TI assumes no liability for applications assistance, customer product design, software performance, or infringement of patents or services described herein. Nor does TI warrant or represent that any license, either express or implied, is granted under any patent right, copyright, mask work right, or other intellectual property right of TI covering or relating to any combination, machine, or process in which such semiconductor products or services might be or are used.

Contents

	<i>Title</i>	<i>Page</i>
Introduction		1
Output-Damping Resistors		1
Reduced-Drive Outputs		4
Practical Applicability of Wave Theory to Predict Signal Waveform Curves		8
Overview of Technologies and Application Areas		10
Transceivers With Output-Damping Resistors or Reduced-Drive Outputs		12
Conclusion		14
Acknowledgment		14
References		14

List of Illustrations

<i>Figure</i>	<i>Title</i>	<i>Page</i>
1	Line-Impedance Matching	1
2	Signal Waveforms Showing Effect of Damping Resistors	2
3	Damping-Resistor Implementation	3
4	Signal Waveforms With Impedance Mismatch ($Z_O = 33 \Omega$, $Z_L = 20 \Omega$)	3
5	Signal Waveforms With Impedance Mismatch ($Z_O = 33 \Omega$, $Z_L = 50 \Omega$)	4
6	Implementation of Various Drive Concepts	5
7	Line Driven By High-, Balanced-, or Light-Drive Device	5
8	Signal Waveforms With High Drive ($Z_O = 6 \Omega$, $Z_L = 33 \Omega$)	6
9	Signal Waveforms With Balanced Drive ($Z_O = 12.5 \Omega$, $Z_L = 33 \Omega$)	6
10	Signal Waveforms With Light Drive ($Z_O = 32 \Omega$, $Z_L = 33 \Omega$)	7
11	Signal Waveforms With Balanced Drive ($Z_O = 12.5 \Omega$, $Z_L = 50 \Omega$)	7
12	Signal Waveforms for SN74ABT244 and SN74ABT2244 Driving a SIMM Module	9
13	Decision Tree for Selecting Driver Output Type	11

List of Tables

<i>Table</i>	<i>Title</i>	<i>Page</i>
1	Low- and High-Level Output Drive Specifications for Selected TI Logic Devices	4
2	Low- and High-Level Output Drive Specifications for FCT16xxx Logic Devices	5
3	Advanced 5-V Buffers With Damping Resistor or Reduced-Drive Options	10
4	Advanced 3.3-V Buffers With Damping Resistor or Reduced-Drive Options	10
5	Advanced Transceivers With High-Drive Outputs on Both Ports (Type 1)	12
6	Advanced Transceivers With High-Drive Outputs on One Port and Damping-Resistor Outputs on the Other Port (Type 2)	12
7	Advanced Transceivers With Balanced-Drive Outputs on One Port and Damping-Resistor Outputs on the Other Port (Type 3)	12
8	Advanced Transceivers With Balanced-Drive Outputs on Both Ports (Type 4)	13
9	Advanced Transceivers With Damping-Resistor Outputs on Both Ports (Type 5)	13
10	Advanced Transceivers With Light-Drive Outputs on Both Ports (Type 6)	13
11	Advanced Transceivers With Reduced-, Unbalanced-Drive Outputs on Both Ports (Type 7)	13

Introduction

The spectrum of bus-interface devices with damping resistors or balanced/light output drive currently offered by various logic vendors is confusing at best. Inconsistencies in naming conventions and methods used for implementation make it difficult to identify the best solution for a given application. This report attempts to clarify the issue by looking at several vendors' approaches and discussing the differences.

Output-Damping Resistors

The purpose of integrating output-damping resistors in line buffers and drivers is to suppress signal undershoots and overshoots on the transmission line through what is usually referred to as line-impedance matching (see Figure 1). The effective output impedance of the line driver (Z_O) is matched with the line impedance (Z_L). Thus, no signal reflection occurs at the line start ($Z_O = Z_L$; reflection coefficient at point A is 0). The input impedance of the receiving device (Z_I) is assumed to be several orders of magnitude higher than the line impedance. This is valid for CMOS and BiCMOS devices. In this case, the reflection coefficient at point B is approximately 1, such that almost all of the wave energy is reflected at the end of the line.

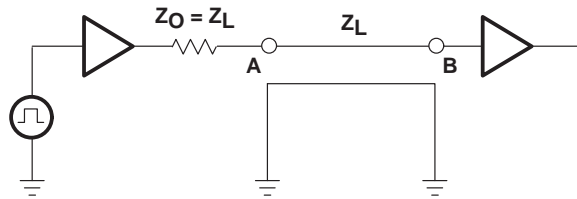

Figure 1. Line-Impedance Matching

Figure 2 illustrates the signal waveforms for a high-to-low transition for a line driver without and with output-damping resistors under these conditions. T is the line signal-transmission time, i.e., the time it takes for the signal wave to travel from point A to point B, or vice versa. The high-level signal prior to the output transition of the line driver has a level of about 3.3 V, typical for 5-V TTL-level devices, such as ABT or FCT-T, as well as for all 3.3-V logic devices. The line impedance is assumed to be 33 Ω .

Without the damping resistor (see Figure 2a), a driver output impedance of 5 Ω is assumed. The incident wave at point A and $t = 0$ establishes a signal level of:

$$V_A = 3.3 \text{ V} \times \left(1 - \frac{33 \text{ } \Omega}{5 \text{ } \Omega + 33 \text{ } \Omega}\right) = 0.43 \text{ V} \quad (1)$$

Due to the reflection at the line end, the receiver (point B) sees the initial line level dropping to

$$V_B = 3.3 \text{ V} - 2 \times (3.3 \text{ V} - 0.43 \text{ V}) = -2.44 \text{ V} \quad (2)$$

which represents a considerable undershoot. With a damping resistor, the effective output impedance is assumed to be 33 Ω , thus matching the line impedance. In this case, while there is a step in the signal at the driver output (point A), the receiver side (point B) sees a very clean signal transition without any significant undershoot or overshoot. Signal waveforms are analogous to this for a low-to-high transition, in which case the line without damping resistors shows significant signal overshoot.

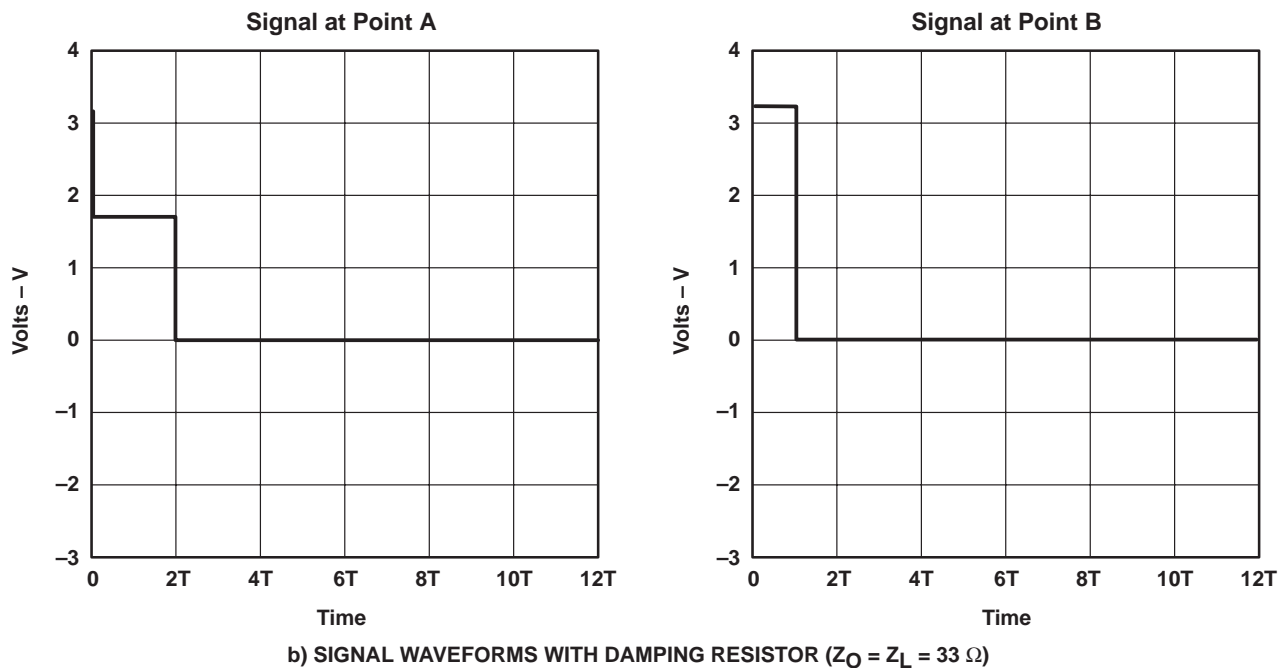
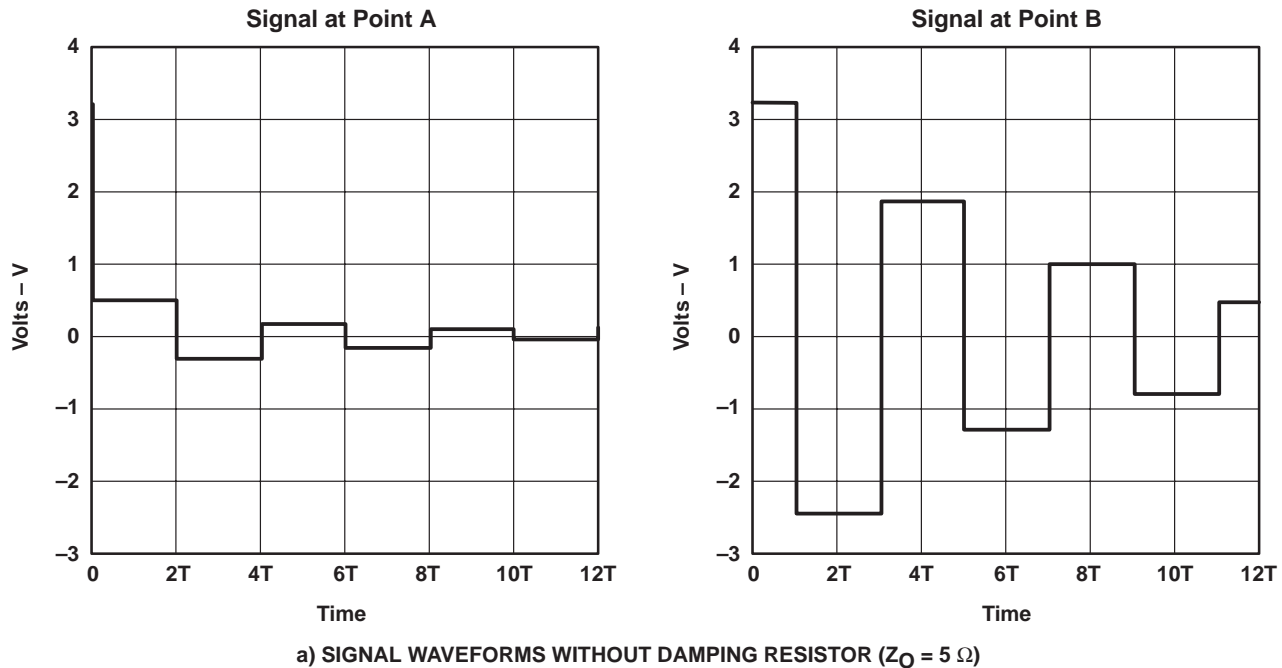

Figure 2. Signal Waveforms Showing Effect of Damping Resistors

The damping-resistor solution is particularly important when designing memory arrays because excessive undershoots and overshoots can cause data loss in memory devices. Although line-impedance matching is optimized for point-to-point transmission where it helps establish near-perfect signal waveforms, it also works fine in most memory-array configurations where there is one driver and many receiving modules. Some of the modules may see a step in the signal waveform (see Figure 2b), but this is only for a short period of time (typically less than 1 ns) and does not affect data transmission. The goal to prevent excessive undershoots and overshoots is still fully accomplished.

Texas Instruments (TI), Philips, and a number of other manufacturers implement output-damping-resistor options in several logic families. The device nomenclature used by all these vendors is a “2” added in front of the device number, that is, the damping-resistor version of the popular ’244 octal buffer is referred to as a ’2244. Having been the first to introduce a ’2244 function with the SN74ALS2244 in the mid-1980s, TI quickly expanded its spectrum of devices with output-damping resistors. Today, it covers the ALS, F, BCT, ABT, LVT, LVC, and ALVC product lines as well as other specialized bus-interface devices.

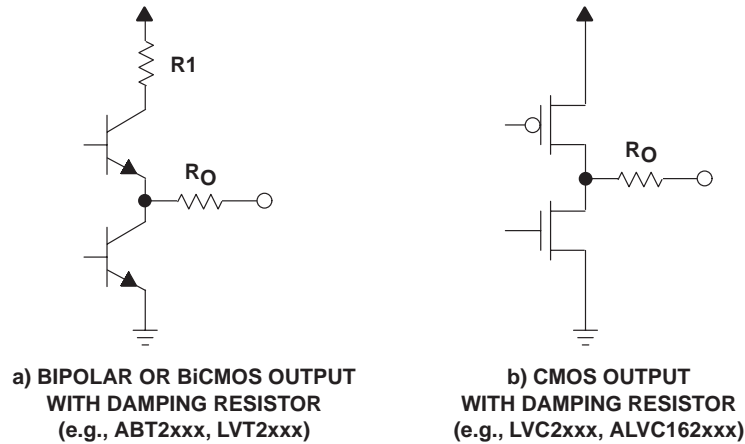

Figure 3. Damping-Resistor Implementation

Figure 3 shows simplified output diagrams that illustrate how damping-resistor outputs are implemented in the ABT/LVT and LVC/ALVC families, respectively.^{2,3} The value of the output-damping resistor (R_O) typically is about $25\ \Omega$. The resistor value in the upper output stage of the bipolar/BiCMOS output, R_1 , is only a few ohms. Together with the impedance of the output stage itself, this leads to an effective total output impedance of about $33\ \Omega$ for all of these circuits. Because line impedance in memory systems is usually around $20\ \Omega$ to $50\ \Omega$ and some level of impedance mismatch is acceptable, this output impedance value covers almost all practical uses. A good rule of thumb is that a mismatch up to a factor of two has little effect on signal characteristics. Figures 4 and 5 show the signal condition for an output-damping-resistor device with a $33\text{-}\Omega$ output impedance and line impedance of $20\ \Omega$ and $50\ \Omega$, respectively. Signal distortion is still acceptable in both cases.

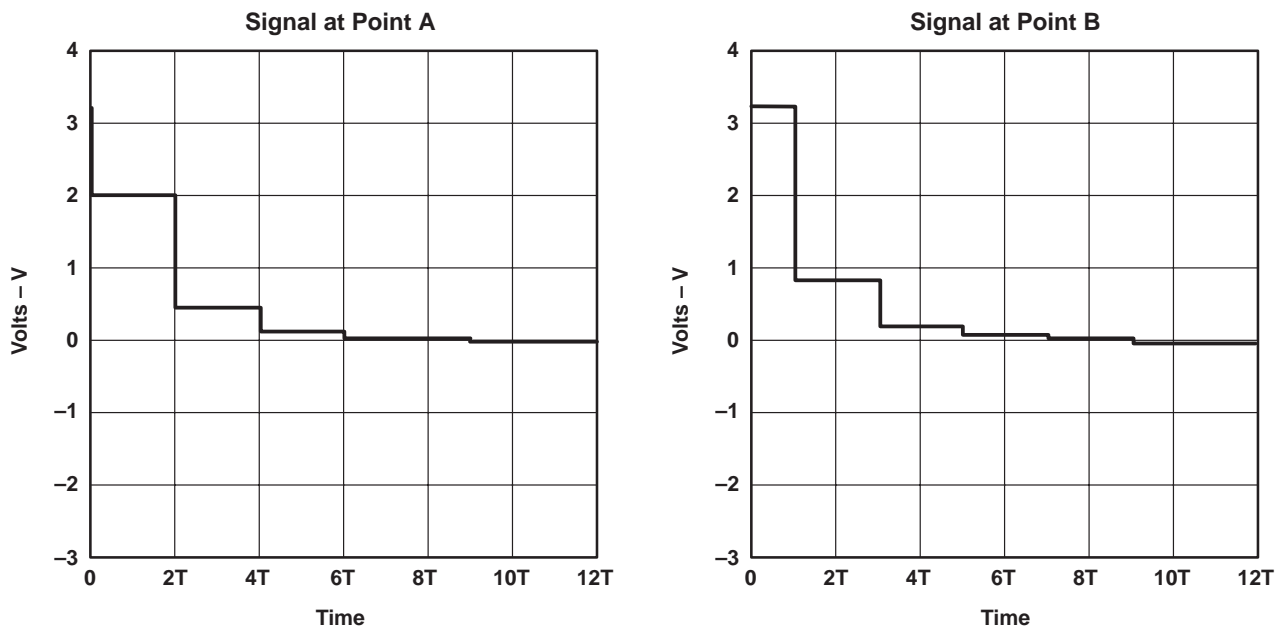

Figure 4. Signal Waveforms With Impedance Mismatch ($Z_O = 33\ \Omega$, $Z_L = 20\ \Omega$)

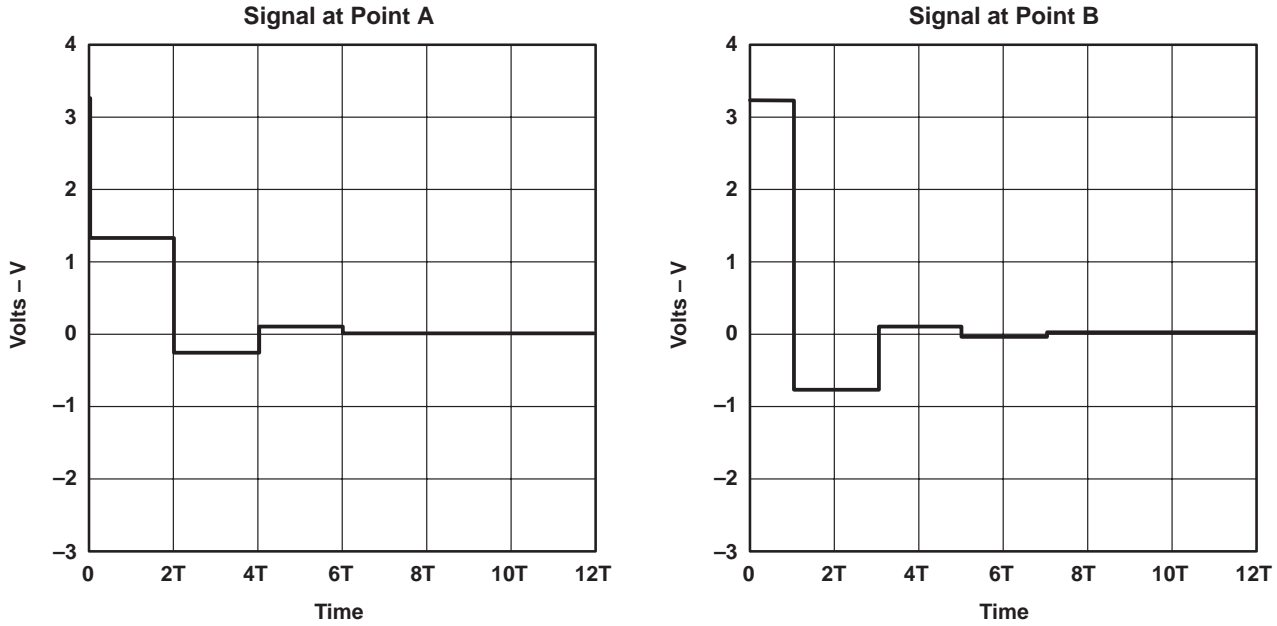

Figure 5. Signal Waveforms With Impedance Mismatch ($Z_O = 33 \Omega$, $Z_L = 50 \Omega$)

The output-stage dimensioning of devices with damping resistors usually remains unchanged. The introduction of the damping resistor reduces the nominal output drive currents, but still leaves a drive capability sufficient for most applications. Table 1 shows low- and high-level output drive specifications for the families previously mentioned. Note that I_{OH} and I_{OL} are balanced on all '2xxx devices.

Table 1. Low- and High-Level Output Drive Specifications for Selected TI Logic Devices

TECHNOLOGY	OUTPUT CURRENT (mA)	
	I_{OH}	I_{OL}
ABTxxx/LVTxxx	-32	64
ABT2xxx/LVT2xxx	-12	12
LVCxxx/ALVC16xxx†	-24	24
LVC2xxx/ALVC162xxx†	-12	12

† ALVC devices are available in Widebus™ versions (16xxx/162xxx) only. All other technologies listed are available in octal and Widebus versions.

Reduced-Drive Outputs

Some vendors refer to balanced- and light-drive outputs. The idea behind these is based on a concept that is different from the damping resistor. While the basic device characteristics remain unchanged and no line termination is added, a balanced- or light-drive device shows significantly reduced output drive currents when compared with its standard high-drive equivalent. In essence, this supports the finding that lower drive currents result in a reduction in undershoot and overshoot.

Figure 6 shows implementations of this approach for FCT16xxx devices.⁴ The impedance values given include the impedance of the FETs. Some manufacturers achieve reduced drive solely by reducing the dimensions of the output FETs, which, in turn, increases their impedance. In this case, no series resistors are added. This helps to reduce the amount of energy (that contributes to undershoots and overshoots), but does not necessarily establish true line-impedance matching because output impedance may remain too low (for example, see the lower output path in Figure 6b).

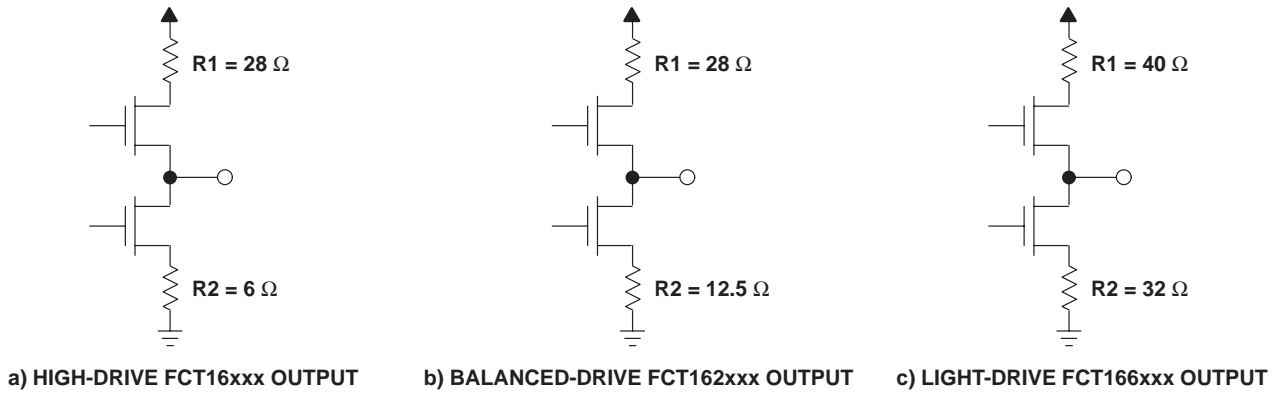

Figure 6. Implementation of Various Drive Concepts

Table 2 shows the resulting nominal output drive specifications.

Table 2. Low- and High-Level Output Drive Specifications for FCT16xxx Logic Devices

DRIVE TYPE		OUTPUT CURRENT (mA)	
		I _{OH}	I _{OL}
FCT16xxx	High drive	-32	64
FCT162xxx	Balanced drive	-24	24
FCT166xxx	Light drive	-8	8

Based on a line with $Z_L = 33 \Omega$ (see Figure 7) showing a high-to-low signal transition, Figures 8 through 10 illustrate the effect on signal undershoot and overshoot. As illustrated in Figure 6, the output impedance of the driver, Z_O , is 6Ω , 12.5Ω , or 32Ω , for high-, balanced-, and light-drive outputs, respectively.

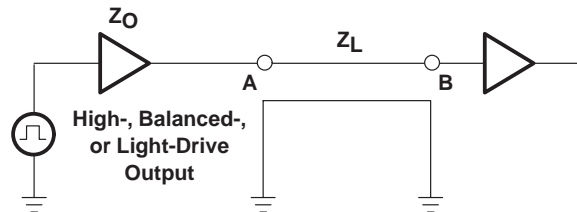

Figure 7. Line Driven By High-, Balanced-, or Light-Drive Device

As expected, the high-drive version (see Figure 8) exhibits signal characteristics very similar to those shown for a standard bus driver without an output-damping resistor (see Figure 2a).

Similarly, signal waveforms with the light-drive version (see Figure 10) resemble those of a bus driver with an output-damping resistor (see Figure 2b). The low nominal output drive of $\pm 8 \text{ mA}$ limits the applicability of these devices to systems where the output drives one or a few receivers only.

While not quite as severe as the high-drive version, the balanced-drive device (see Figure 9) still causes considerable undershoots because its low-level output impedance of 12.5Ω is too low to match the line impedance. It becomes worse if line impedance is higher than 33Ω . Figure 11 demonstrates this, assuming a line impedance of 50Ω .

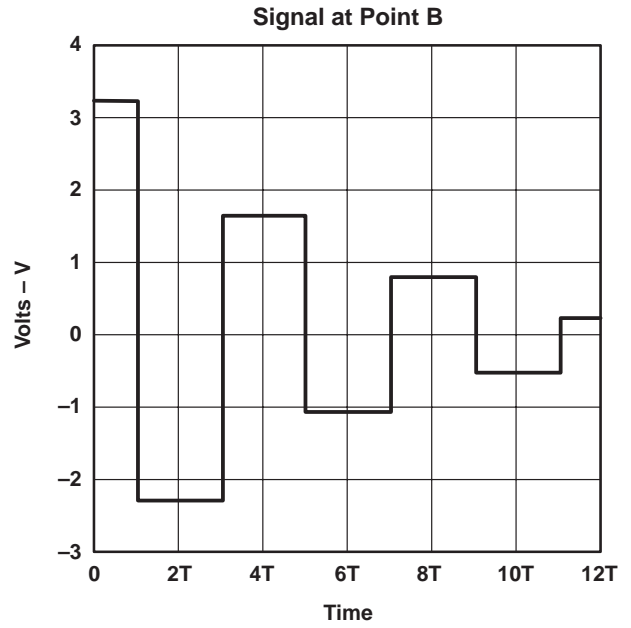
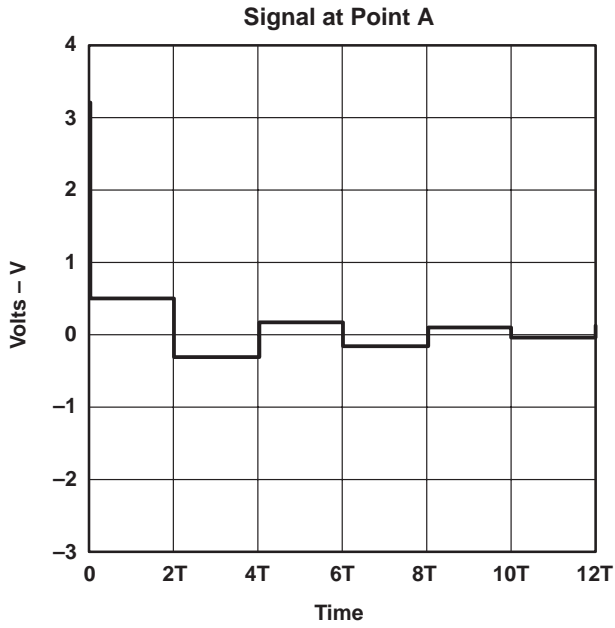

Figure 8. Signal Waveforms With High Drive ($Z_O = 6 \Omega$, $Z_L = 33 \Omega$)

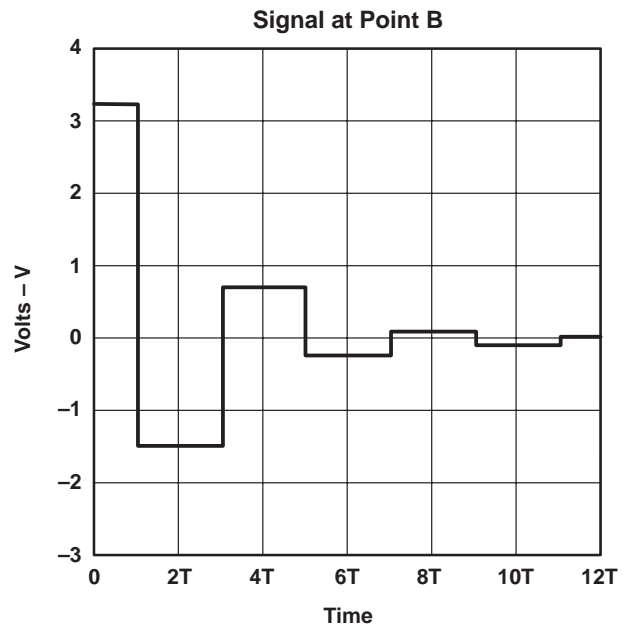
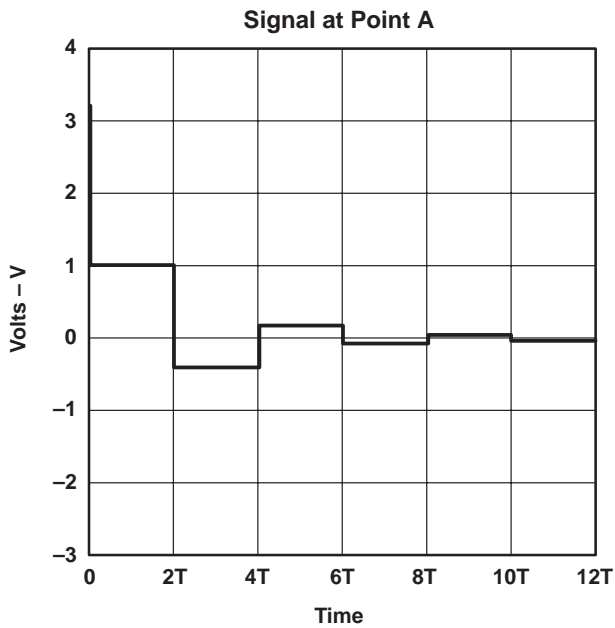

Figure 9. Signal Waveforms With Balanced Drive ($Z_O = 12.5 \Omega$, $Z_L = 33 \Omega$)

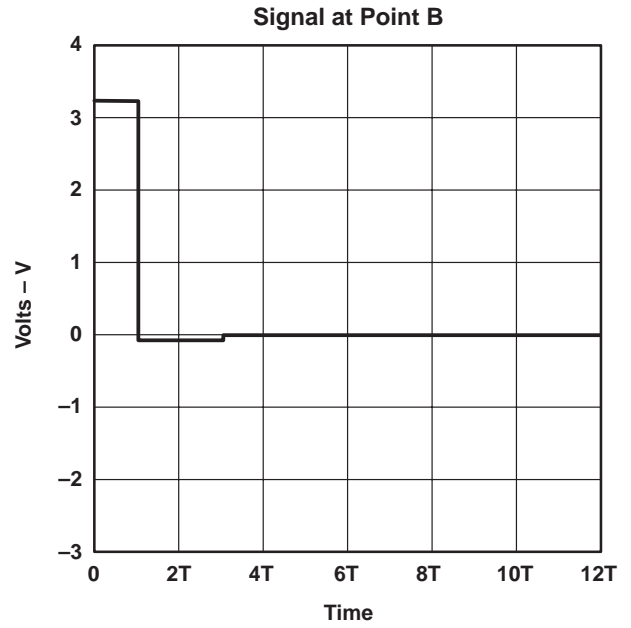
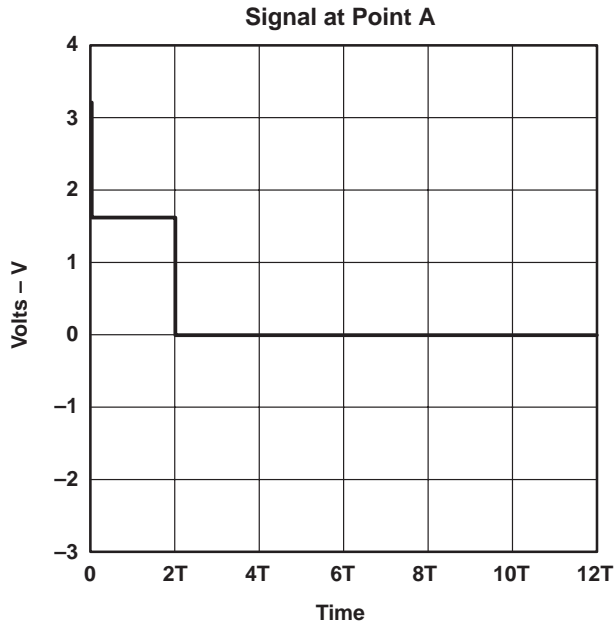

Figure 10. Signal Waveforms With Light Drive ($Z_O = 32 \Omega$, $Z_L = 33 \Omega$)

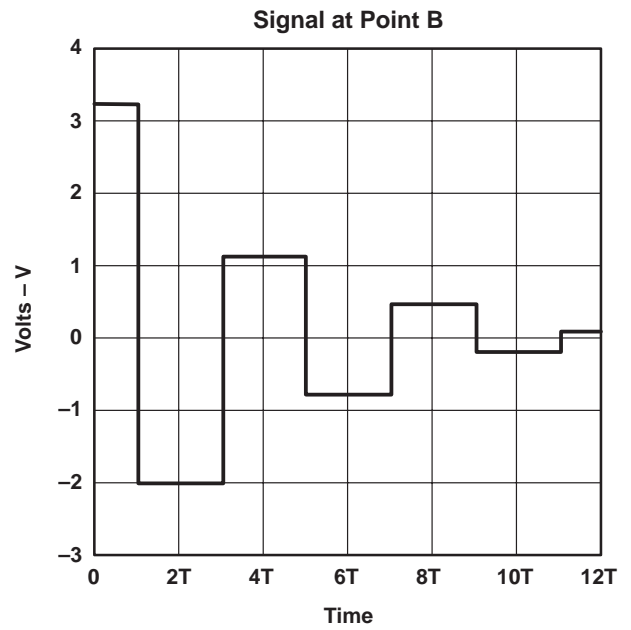
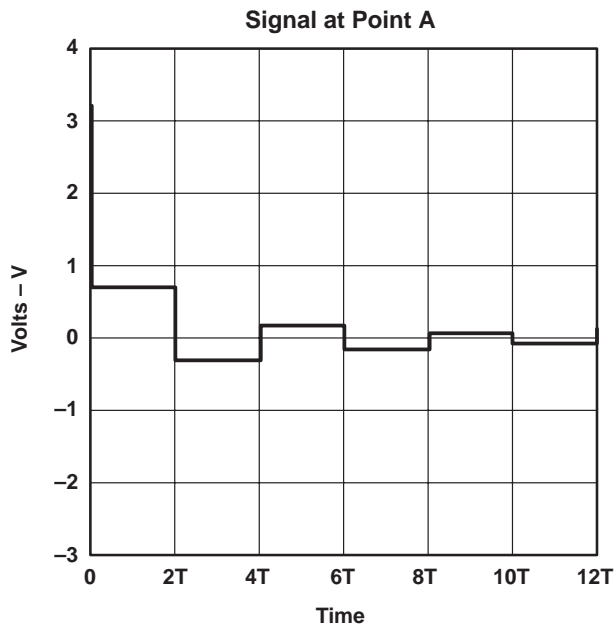

Figure 11. Signal Waveforms With Balanced Drive ($Z_O = 12.5 \Omega$, $Z_L = 50 \Omega$)

Practical Applicability of Wave Theory to Predict Signal Waveform Curves

Obviously, all signal waveforms shown in Figures 2, 4, 5, and 8 through 11 are derived from wave theory. They assume a line without terminating impedance, which is an acceptable approximation when using today's CMOS receivers with their very high input impedances, but ignores the output loading effects by the capacitive loads that receiver inputs, connectors, traces, etc., represent. While these theoretical curves help in understanding the influence of output and line impedances, a necessary question is, therefore, whether the curves reflect real-world signal waveforms closely enough to be useful.

With heavily loaded outputs, typically with line impedances of $30\ \Omega$ or below, in practice, heavily distorted signal waveforms are found. Damping-resistor outputs do not improve this much. Other termination techniques may be more appropriate but lead to acceptable signal waveforms only of a line driver with very-high-output drive capability. The signal distortion often results in extended signal-propagation times because one or more reflections are needed before a well-defined signal level is established. Sometimes, slow signal slew rates prevent excessive signal bounces such that undershoots and overshoots do not reach critical levels. However, relying upon this to suppress undershoot and overshoots is not a good design practice. Figure 12 shows measured curves derived from SN74ABT244 and SN74ABT2244 devices, respectively, driving a SIMM memory module with 18 memory devices. As before, the driver output is referred to as point A and the receiver, in this case the memory device that is the farthest away from the driver, as point B. The curves illustrate quite well how the strong capacitive loading represented by the memories distorts the reflected waves. Signal undershoot on the receiver side is still overcritical in the standard device without a damping resistor, while the damping-resistor version ensures that no undershoot occurs.

Lightly loaded lines represent another problematic application for devices that do not have an output-damping resistor. Here, the aforementioned slew-rate reduction can be expected to improve things only marginally. Therefore, with line impedances of $50\ \Omega$ or more, that is, in applications where there are only a few receiving devices connected to the line, in practice, waveforms usually are very similar to theoretical ones. Large undershoots and overshoots occur if the line is left unterminated.

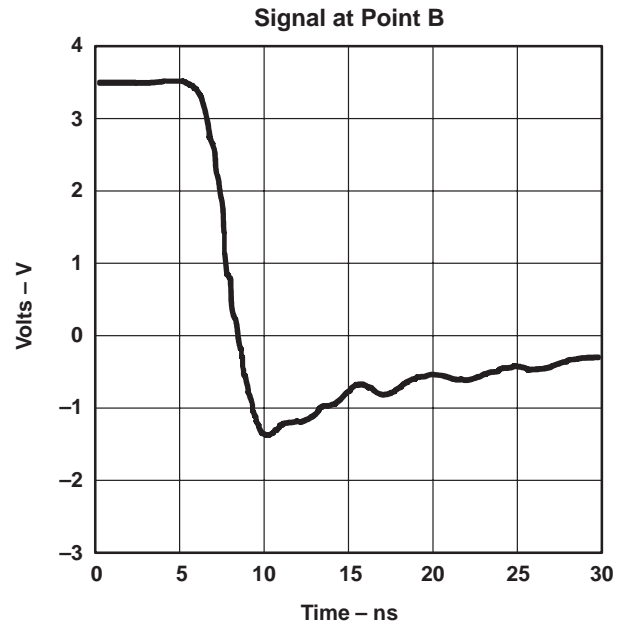
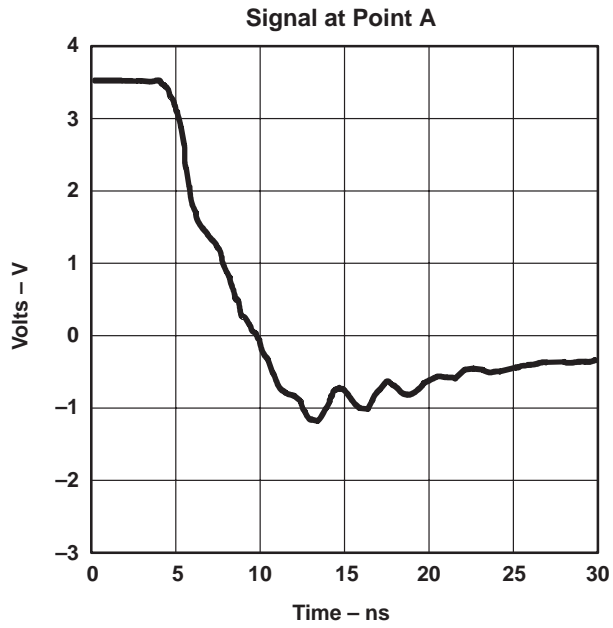

a) SN74ABT244 (WITHOUT DAMPING RESISTOR)

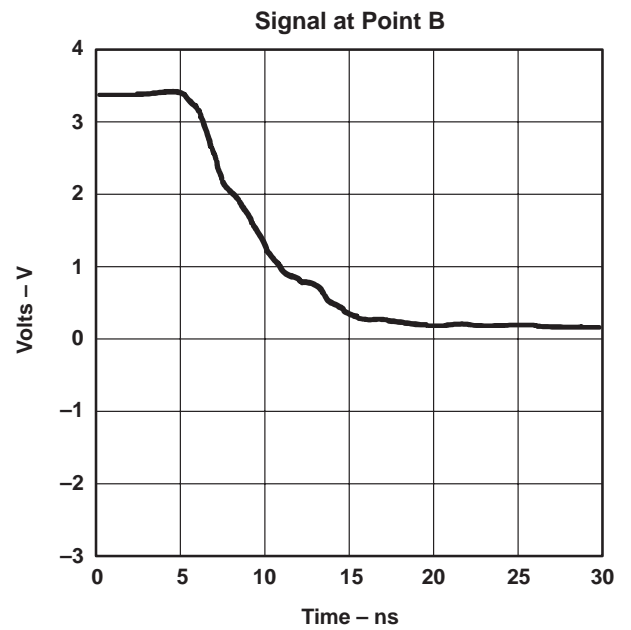
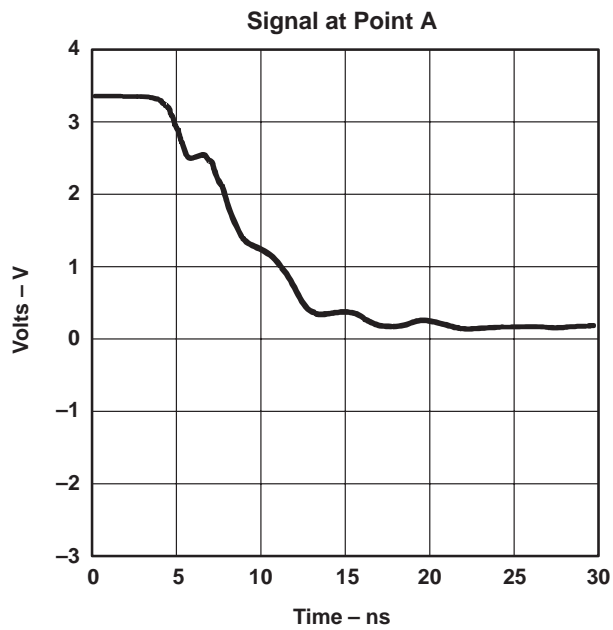

b) SN74ABT2244 (WITH DAMPING RESISTOR)

Figure 12. Signal Waveforms for SN74ABT244 and SN74ABT2244 Driving a SIMM Module

Overview of Technologies and Application Areas

As mentioned before, the spectrum of available bus-interface devices with damping resistors or reduced output drive currently offered by various logic vendors is very confusing. This is mainly because similar naming conventions are being used for different approaches. Tables 3 and 4 give an overview of advanced 5-V and 3.3-V logic families. Please note that the device series field ignores other vendor-specific parts of device names, such as device revisions or indicators for bus-hold device inputs.

Table 3. Advanced 5-V Buffers With Damping Resistor or Reduced-Drive Options

DEVICE SERIES	VENDOR	TYPE	I _{OH} (mA)	I _{OL} (mA)	COMMENTS
ABTxxx	TI, Philips, et al.	High drive	-32	64	
ABT16xxx	TI, Philips, et al.	High drive	-32	64	Same as octal version (ABTxxx)
ABT2xxx	TI, Philips, et al.	Damping resistor	-12	12	
ABT162xxx	TI, Philips, et al.	Damping resistor	-12	12	Same as octal version (ABT2xxx)
AC/ACTxxx	TI, Motorola, et al.	Balanced drive	-24	24	
AC/ACT16xxx	TI	Balanced drive	-24	24	Same as octal version (AC/ACTxxx)
AHC/AHCTxxx	TI, Philips, et al.	Light drive	-8	8	
FCTxxx	IDT, QSI, et al.	High drive	-15	64	
FCT16xxx	IDT, QSI, et al.	High drive	-32	64	I _{OH} differs from octal version (FCTxxx)
FCT2xxx	IDT, QSI, et al.	Balanced drive	-15	12	
FCT162xxx	IDT, QSI, et al.	Balanced drive	-24	24	I _{OH} , I _{OL} differ from octal version (FCT2xxx)
FCT162Qxxx	Pericom	Damping resistor	-12	12	No octal version
FCT166xxx	IDT	Light drive	-8	8	No octal version

While FCT16xxx versions have the same output drive as ABT, FCT162xxx corresponds to technologies such as AC and ACT. FCT166xxx has the low output drive of families like HC/HCT or AHC/AHCT. Note that FCT characteristics are different for octals and 16-bit versions. This may lead to different signal waveforms in practical applications. All TI logic families have identical characteristics for octal and Widebus devices.

Table 4. Advanced 3.3-V Buffers With Damping Resistor or Reduced-Drive Options

DEVICE SERIES	VENDOR	TYPE	I _{OH} (mA)	I _{OL} (mA)	COMMENTS
LVTxxx	TI, Philips, et al.	High drive	-32	64	
LVT16xxx	TI, Philips, et al.	High drive	-32	64	Same as octal version (LVTxxx)
ALVT16xxx	TI, Philips, et al.	High drive	-32	64	No octal version
LVT2xxx	TI, Philips, et al.	Damping resistor	-12	12	
LVT162xxx	TI, Philips, et al.	Damping resistor	-12	12	Same as octal version (LVT2xxx)
ALVT162xxx	TI, Philips, et al.	Damping resistor	-12	12	No octal version
LVCxxx	TI, Philips, et al.	Balanced drive	-24	24	
LVC16xxx	TI, Philips, et al.	Balanced drive	-24	24	Same as octal version (LVCxxx)
LVC2xxx	TI	Damping resistor	-12	12	
LVC162xxx	TI	Damping resistor	-12	12	Same as octal version (LVC2xxx)
ALVC16xxx	TI, Philips, et al.	Balanced drive	-24	24	No octal version
ALVC162xxx	TI	Damping resistor	-12	12	No octal version
LVxxx	TI, Philips, et al.	Light drive	-8	8	
LCXxxx	Fairchild, et al.	Balanced drive	-24	24	No reduced-drive versions available
LCX16xxx	Fairchild, et al.	Balanced drive	-24	24	Same as octal version (LCXxxx)
FCT3xxx	IDT, QSI, et al.	Reduced, unbalanced drive	-8	24	No high-drive versions available
FCT163xxx	IDT, QSI, et al.	Reduced, unbalanced drive	-8	24	Same as octal version (FCT3xxx)

LVT and ALVT are the only high-drive 3.3-V logic families available in the market. For 3.3 V, only the LVT, ALVT, LVC, and ALVC product families offer true damping-resistor options. FCT3xxx and FCT163xxx devices have significantly lower drive capability than their 5-V equivalents. Also, their I_{OH}/I_{OL} drive currents are unbalanced, which limits their use in certain applications.

Application areas for damping-resistor and reduced-drive line buffers and transceivers cover many different types of end equipment. In addition to required device function, output loading (line impedance) and available termination are the decisive factors when choosing a device. The decision tree shown in Figure 13 provides a general guideline. However, specific requirements may represent further constraints.

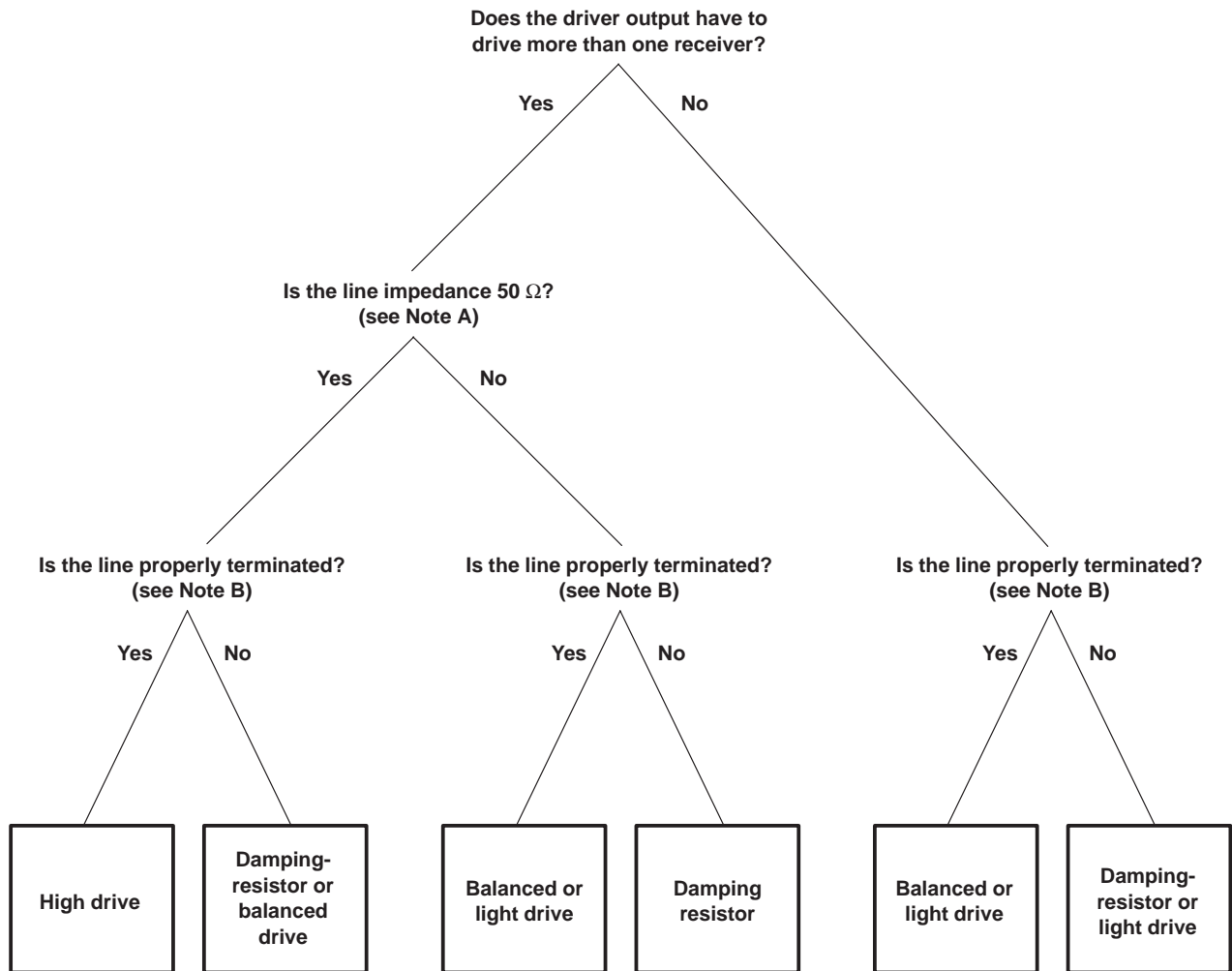

- NOTES: A. If exact line impedance is unknown, a good rule of thumb is that line impedance is lower than 50 Ω if more than four or five receiver inputs are connected to the line.
 B. Examples of other line-termination methods are a split-resistor (Thevenin) network, an R-C combination, or clamping diodes. A more detailed discussion of advantages and disadvantages of these and other termination methods is found in reference 3.

Figure 13. Decision Tree for Selecting Driver Output Type

Transceivers With Output-Damping Resistors or Reduced-Drive Outputs

So far, this report has dealt with buffers and line drivers only, and has shown that several different output versions support a wide range of output load configurations.

The number of choices is even larger when looking at transceivers because any combination of output versions can be chosen independently for the A port and B port of the device. Not all possible combinations are being offered in the market, but the list of drive types is extensive.

1. High-drive outputs on both ports
2. High-drive outputs on one port and damping-resistor outputs on the other port
3. Balanced-drive outputs on one port and damping-resistor outputs on the other port
4. Balanced-drive outputs on both ports
5. Damping-resistor outputs on both ports
6. Light-drive outputs on both ports
7. Reduced-, unbalanced-drive outputs on both ports

The best combination for a particular application can be determined using the decision tree in Figure 13 independently for the A and B ports of the transceiver. In general, applications that require a transceiver between a backplane and a local board require types 1 or 2 (type 3 may work in some applications). Applications with more lightly loaded local buses on both sides require any one of types 2 through 5, while type 6 addresses point-to-point transmission requirements.

The spectrum of devices offered in the market is complex and difficult to comprehend. Tables 5 through 11 show the options available for each type.

Table 5. Advanced Transceivers With High-Drive Outputs on Both Ports (Type 1)

DEVICE	V _{CC}	VENDOR	COMMENTS
ABTxxx	5 V	TI, Philips, et al.	
ABT16xxx	5 V	TI, Philips, et al.	
FCTxxx	5 V	IDT, QSI, et al.	
FCT16xxx	5 V	IDT, QSI, et al.	I _{OH} differs from octal version (FCTxxx)
LVTxxx	3.3 V	TI, Philips, et al.	
LVT16xxx	3.3 V	TI, Philips, et al.	

Table 6. Advanced Transceivers With High-Drive Outputs on One Port and Damping-Resistor Outputs on the Other Port (Type 2)

DEVICE	V _{CC}	VENDOR
ABT2xxx	5 V	TI
ABT162xxx	5 V	TI
LVT2xxx	3.3 V	TI
LVT162xxx	3.3 V	TI
ALVT162xxx	3.3 V	TI

Table 7. Advanced Transceivers With Balanced-Drive Outputs on One Port and Damping-Resistor Outputs on the Other Port (Type 3)

DEVICE	V _{CC}	VENDOR
LVC2xxx	3.3 V	TI
LVC162xxx	3.3 V	TI
ALVC162xxx	3.3 V	TI

Table 8. Advanced Transceivers With Balanced-Drive Outputs on Both Ports (Type 4)

DEVICE	V _{CC}	VENDOR	COMMENTS
AC/ACTxxx	5 V	TI, Motorola, et al.	
AC/ACT16xxx	5 V	TI	
FCT2xxx	5 V	IDT, QSI, et al.	
FCT162xxx	5 V	IDT, QSI, et al.	I _{OH} , I _{OL} differ from octal version (FCT2xxx)
LVCxxx	3.3 V	TI, Philips, et al.	
LVC16xxx	3.3 V	TI, Philips, et al.	
ALVC16xxx	3.3 V	TI, Philips, et al.	
LCXxxx	3.3 V	Fairchild, et al.	
LCX16xxx	3.3 V	Fairchild, et al.	

Table 9. Advanced Transceivers With Damping-Resistor Outputs on Both Ports (Type 5)

DEVICE	V _{CC}	VENDOR	COMMENTS
ABTRxxx	5 V	TI	Same nomenclature, but different type from TI ABT162xxx
ABT162xxx	5 V	Philips	
FCT162Qxxx	5 V	Pericom	
LVCR2xxx	3.3 V	TI	
LVCR162xxx	3.3 V	TI	
ALVCR162xxx	3.3 V	TI	
ALVC162xxx	3.3 V	Philips	Same nomenclature, but different type from TI ALVC162xxx
LVT162xxx	3.3 V	Philips	Same nomenclature, but different type from TI LVT162xxx
ALVT162xxx	3.3 V	Philips	Same nomenclature, but different type from TI ALVT162xxx

Table 10. Advanced Transceivers With Light-Drive Outputs on Both Ports (Type 6)

DEVICE	V _{CC}	VENDOR
AHC/AHCTxxx	5 V	TI, Philips, et al.
FCT166xxx	5 V	IDT
LVxxx	3.3 V	TI, Philips, et al.

Table 11. Advanced Transceivers With Reduced-, Unbalanced-Drive Outputs on Both Ports (Type 7)

DEVICE	V _{CC}	VENDOR	COMMENTS
FCT3xxx	3.3 V	IDT, QSI, et al.	
FCT163xxx	3.3 V	IDT, QSI, et al.	I _{OH} , I _{OL} differ from octal version (FCT3xxx)

The majority of solutions offered are symmetrical, that is, they use the same output type on the A port and on the B port. While this may appear logical, it does not address the needs of most backplane-based applications where the backplane usually requires a high-drive output. TI was the first to introduce a transceiver with output-damping resistors, the SN74BCT2245, and since then has used the AAA2xxx or AAA162xxx concept (AAA = family indicator, xxx = device number) to indicate a device with standard (high or balanced) drive on one side and damping-resistor outputs on the other side. Others, including Philips, use the same nomenclature to indicate both output sides having damping resistors. TI uses AAAR2xxx or AAAR162xxx for this arrangement.

Conclusion

While buffers or transceivers with integrated output-damping resistors or reduced-drive outputs are required by many applications, the system designer needs to carefully choose a solution because vendors' denomination methods for these devices may be confusing. In particular, the difference between true damping resistors, i.e., integrated series resistors in the output path, and reduced-drive outputs, where the output drive is limited through changing the dimensioning and/or adding a resistor to the upper and lower transistor of the output stage, needs to be understood relative to different applications.

TI is the only vendor who offers 5-V and 3.3-V versions of all driver output types discussed in this report.

Acknowledgment

The author of this document is Lothar Katz.

References

- 1 Curtis, Rick; Forstner, Peter; "Memory Driver Application Report", EB 205E, Texas Instruments (www.ti.com/sc/docs/asl/lit/eb205.htm).
- 2 Texas Instruments, "ABT Enables Optimal System Design", SCBA001 (www.ti.com/sc/docs/psheets/appnote.htm).
- 3 Texas Instruments, "Proper Termination of Outputs", *LVC Designer's Guide*, SCBA010, page 1–27ff.
- 4 Hronik, Stanley, "Effective Use of Line Termination in High Speed Logic", Integrated Device Technology, Inc., Conference Paper CP-23 (www.idt.com/cgi-bin/dsq.pl?mkgkey=logicgen).
- 5 Texas Instruments, SN74ABTxxx, SN74LVCxxx, SN74ALVCxxx, and SN74LVTxxx data sheets (www.sc.ti.com/sc/docs/psheets/pids2.htm).
- 6 Integrated Device Technology, IDT54/74FCTxxx data sheets (www.idt.com/logic/Welcome.html).
- 7 Pericom, PI74FCTxxx data sheets (www.pericom.com/products/sinter).
- 8 Philips Semiconductors, 74ABTxxx, 74LVCxxx, 74ALVCxxx, and 74ALVTxxx data sheets (www.semiconductors.philips.com/philips54.html#3).