

TAS5727 25-W Digital Audio Power Amplifier With EQ and DRC

1 Features

- Audio Input and Output
 - 25 W Into an 8-Ω Load From a 20-V Supply
 - Wide PVDD Range, From 8 V to 26 V
 - Supports BTL Configuration With 4-Ω Load
 - Efficient Class-D Operation Eliminates Need for Heatsinks
 - One Serial Audio Input (Two Audio Channels)
 - I²C Address Selection Pin (Chip Select)
 - Single Output Filter PBTl Support
 - Supports 44.1-kHz to 48-kHz Sample Rate (LJ/RJ/I²S)
- Audio and PWM Processing
 - Independent Channel Volume Controls With Gain of 24 dB to Mute With 0.125-dB Resolution Steps
 - Programmable Two-Band Dynamic-Range Control
 - 18 Programmable Biquads for Speaker EQ and Other Audio-Processing Features
 - Programmable Coefficients for DRC Filters
 - DC Blocking Filters
- General Features
 - I²C Serial Control Interface Operational Without MCLK
 - Requires Only 3.3 V and PVDD
 - No External Oscillator: Internal Oscillator for Automatic Rate Detection
 - Surface-Mount, 48-Pin HTQFP Package
 - Thermal and Short-Circuit Protection
 - 106-dB SNR, A-Weighted

- AD, BD, and Ternary Modulation
- Up to 90% Efficient
- PWM Level Meter to Measure the Digital Power Profile
- Benefits
 - EQ: Speaker Equalization Improves Audio Performance
 - Two-Band DRC: Dynamic Range Compression. Can Be Used As Power Limiter. Enables Speaker Protection, Easy Listening, Night-Mode Listening
 - Autodetect: Automatically Detects Sample-Rate Changes. No Need for External Microprocessor Intervention

2 Applications

- LCD TV, LED TV, Soundbar

3 Description

The TAS5727 is a 25-W, efficient, digital-audio power amplifier for driving stereo bridge-tied speakers. One serial data input allows processing of up to two discrete audio channels and seamless integration to most digital audio processors and MPEG decoders. The device accepts a wide range of input data and data rates. A fully programmable data path routes these channels to the internal speaker drivers.

Device Information⁽¹⁾

PART NUMBER	PACKAGE	BODY SIZE (NOM)
TAS5727	HTQFP (48)	7.00 mm x 7.00 mm

(1) For all available packages, see the orderable addendum at the end of the data sheet.

Functional View

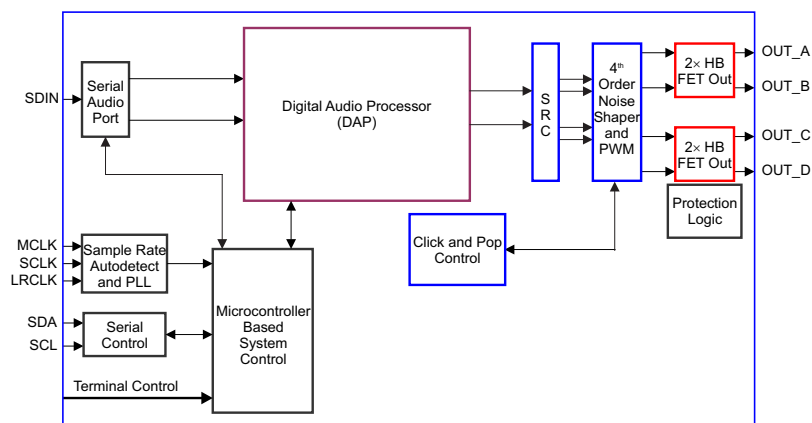

B0262-06

Copyright © 2016 Texas Instruments Incorporated



Table of Contents

1 Features	1	10.2 Functional Block Diagrams	13
2 Applications	1	10.3 Feature Description	15
3 Description	1	10.4 Device Functional Modes	28
4 Revision History	2	10.5 Programming	29
5 Description (continued)	3	10.6 Register Maps	31
6 Device Comparison Table	3	11 Application and Implementation	54
7 Pin Configuration and Functions	4	11.1 Application Information	54
8 Specifications	6	11.2 Typical Applications	54
8.1 Absolute Maximum Ratings	6	12 Power Supply Recommendations	59
8.2 ESD Ratings	6	12.1 DVDD and AVDD Supplies	59
8.3 Recommended Operating Conditions	6	12.2 PVDD Power Supply	59
8.4 Thermal Information	7	13 Layout	60
8.5 DC Electrical Characteristics	7	13.1 Layout Guidelines	60
8.6 AC Electrical Characteristics (BTL, PBTL)	8	13.2 Layout Example	60
8.7 PLL Input Parameters and External Filter Components	8	14 Device and Documentation Support	61
8.8 Serial Audio Ports Slave Mode	8	14.1 Device Support	61
8.9 I ² C Serial Control Port Operation	9	14.2 Documentation Support	61
8.10 Reset Timing (RESET)	9	14.3 Receiving Notification of Documentation Updates	61
8.11 Typical Characteristics	11	14.4 Community Resources	61
9 Parameter Measurement Information	12	14.5 Trademarks	61
10 Detailed Description	13	14.6 Electrostatic Discharge Caution	61
10.1 Overview	13	14.7 Glossary	61
		15 Mechanical, Packaging, and Orderable Information	61

4 Revision History

NOTE: Page numbers for previous revisions may differ from page numbers in the current version.

Changes from Revision A (May 2016) to Revision B Page

- Added Note 1 to PVDD_x in the *Recommended Operating Conditions* table **6**

Changes from Original (November 2010) to Revision A Page

- Added *ESD Ratings* table, *Feature Description* section, *Device Functional Modes*, *Application and Implementation* section, *Power Supply Recommendations* section, *Layout* section, *Device and Documentation Support* section, and *Mechanical, Packaging, and Orderable Information* section. **1**
- Changed Section: Overcurrent (OC) Protection With Current Limiting **16**
- Changed Section: Overcurrent (OC) Protection With Current Limiting and Overload Detection **16**

5 Description (continued)

The TAS5727 is a slave-only device receiving all clocks from external sources. The TAS5727 operates with a PWM carrier between a 384-kHz switching rate and a 288-KHz switching rate, depending on the input sample rate. Oversampling combined with a fourth-order noise shaper provides a flat noise floor and excellent dynamic range from 20 Hz to 20 kHz.

6 Device Comparison Table

	TAS5727	TAS5729MD	TAS5731M	TAS5721
Maximum power to single-ended load			18	10
Maximum power to bridge tied load	35	20	37	15
Maximum power to parallel bridge tied load	70	40	70	30
Minimum supported single-ended load			2	4
Minimum supported bridge tied load	4	4	4	8
Minimum supported parallel bridge tied load	2	4	2	4
Closed- or open-loop	Open	Open	Open	Open
Maximum speaker outputs (#)	2	2	3	3
Headphone channels	No	Yes	No	Yes
Architecture	Class D	Class D	Class D	Class D
Dynamic range control (DRC)	2-Band AGL	2-Band AGL	2-Band DRC	2-Band DRC
Biquads (EQ)	28	28	21	21

7 Pin Configuration and Functions

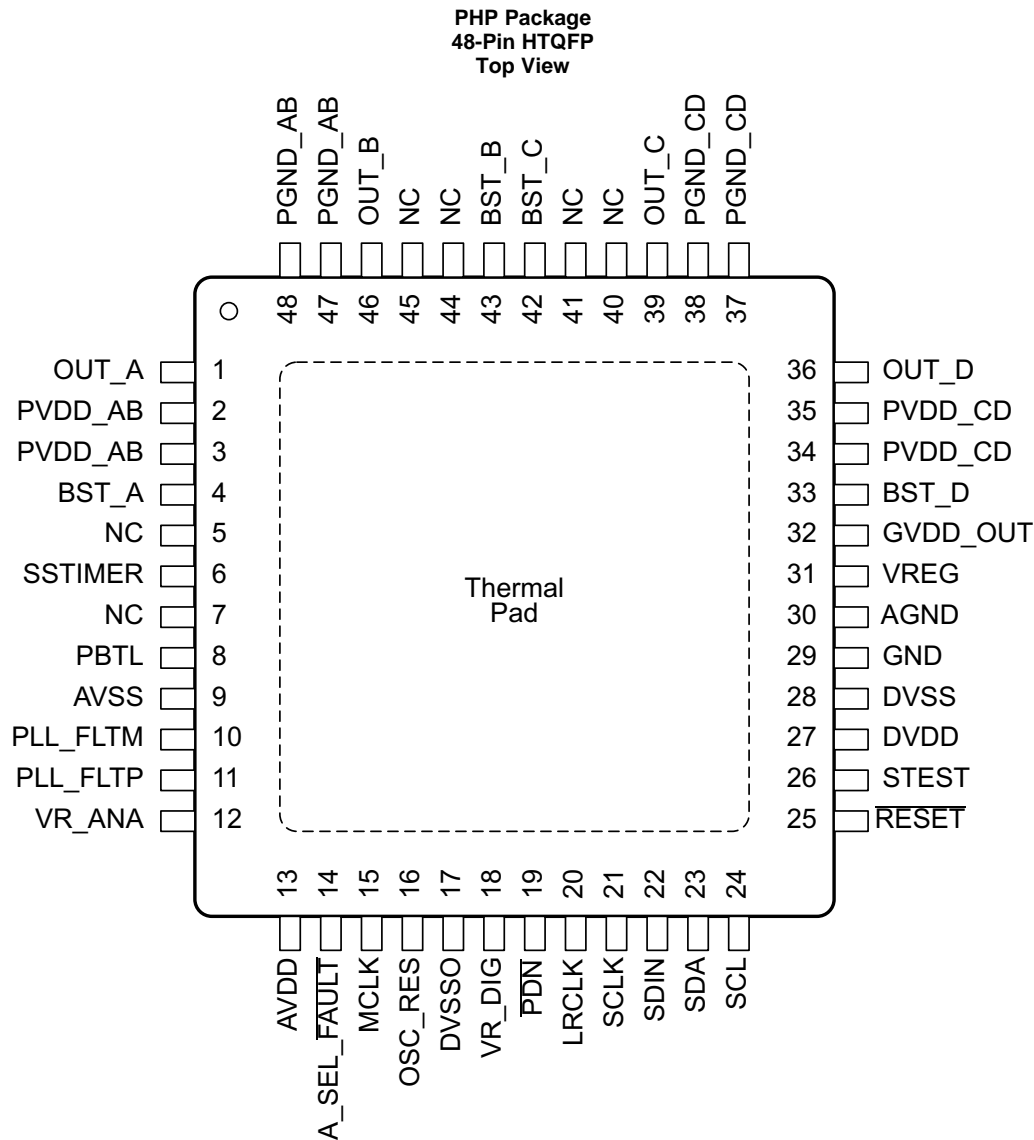

Pin Functions

PIN		TYPE ⁽¹⁾	5-V TOLERANT	TERMINATION ⁽²⁾	DESCRIPTION
NAME	NO.				
AGND	30	P			Local analog ground for power stage
A_SEL_FAULT	14	DIO			This pin is monitored on the rising edge of RESET. A value of 0 (15-k Ω pulldown) sets the I ² C device address to 0x54 and a value of 1 (15-k Ω pullup) sets it to 0x56. this dual-function pin can be programmed to output internal power-stage errors.
AVDD	13	P			3.3-V analog power supply
AVSS	9	P			Analog 3.3-V supply ground
BST_A	4	P			High-side bootstrap supply for half-bridge A
BST_B	43	P			High-side bootstrap supply for half-bridge B

(1) TYPE: A = analog; D = 3.3-V digital; P = power/ground/decoupling; I = input; O = output

(2) All pullups are weak pullups and all pulldowns are weak pulldowns. The pullups and pulldowns are included to assure proper input logic levels if the pins are left unconnected (pullups → logic 1 input; pulldowns → logic 0 input).

Pin Functions (continued)

PIN		TYPE ⁽¹⁾	5-V TOLERANT	TERMINATION ⁽²⁾	DESCRIPTION
NAME	NO.				
BST_C	42	P			High-side bootstrap supply for half-bridge C
BST_D	33	P			High-side bootstrap supply for half-bridge D
DVDD	27	P			3.3-V digital power supply
DVSS	28	P			Digital ground
DVSSO	17	P			Oscillator ground
GND	29	P			Analog ground for power stage
GVDD_OUT	32	P			Gate drive internal regulator output
LRCLK	20	DI	5-V	Pulldown	Input serial audio data left and right clock (sample-rate clock)
MCLK	15	DI	5-V	Pulldown	Master clock input
NC	5, 7, 40, 41, 44, 45	–			No connect
OSC_RES	16	AO			Oscillator trim resistor. Connect an 18.2-kΩ, 1% resistor to DVSSO.
OUT_A	1	O			Output, half-bridge A
OUT_B	46	O			Output, half-bridge B
OUT_C	39	O			Output, half-bridge C
OUT_D	36	O			Output, half-bridge D
PBTL	8	DI			Low means BTL mode; high means PBTL mode. Information goes directly to power stage.
$\overline{\text{PDN}}$	19	DI	5-V	Pullup	Power down, active-low. $\overline{\text{PDN}}$ prepares the device for loss of power supplies by shutting down the noise shaper and initiating the PWM stop sequence.
PGND_AB	47, 48	P			Power ground for half-bridges A and B
PGND_CD	37, 38	P			Power ground for half-bridges C and D
PLL_FLTM	10	AO			PLL negative loop-filter terminal
PLL_FLTP	11	AO			PLL positive loop-filter terminal
PVDD_AB	2, 3	P			Power-supply input for half-bridge output A
PVDD_CD	34, 35	P			Power-supply input for half-bridge output D
$\overline{\text{RESET}}$	25	DI	5-V	Pullup	Reset, active-low. A system reset is generated by applying a logic low to this pin. RESET is an asynchronous control signal that restores the DAP to its default conditions and places the PWM in the hard-mute (high-impedance) state.
SCL	24	DI	5-V		I ² C serial control clock input
SCLK	21	DI	5-V	Pulldown	Serial audio-data clock (shift clock). SCLK is the serial-audio-port input-data bit clock.
SDA	23	DIO	5-V		I ² C serial control data interface input/output
SDIN	22	DI	5-V	Pulldown	Serial audio data input. SDIN supports three discrete (stereo) data formats.
SSTIMER	6	AI			Controls ramp time of OUT_x to minimize pop. Leave this pin floating for BD mode. Requires capacitor of 2.2 nF to GND in AD mode. The capacitor determines the ramp time.
STEST	26	DI			Factory test pin. Connect directly to DVSS.
VR_ANA	12	P			Internally regulated 1.8-V analog supply voltage. This pin must not be used to power external devices.
VR_DIG	18	P			Internally regulated 1.8-V digital supply voltage. This pin must not be used to power external devices.
VREG	31	P			Digital regulator output. Not to be used for powering external circuitry.

8 Specifications

8.1 Absolute Maximum Ratings

over operating free-air temperature range (unless otherwise noted)⁽¹⁾

		MIN	MAX	UNIT
Supply voltage	DVDD, AVDD	-0.3	3.6	V
	PVDD_x	-0.3	30	V
Input voltage	3.3-V digital input	-0.5	DVDD + 0.5	V
	5-V tolerant ⁽²⁾ digital input (except MCLK)	-0.5	DVDD + 2.5 ⁽³⁾	
	5-V tolerant MCLK input	-0.5	AVDD + 2.5 ⁽³⁾	
OUT_x to PGND_x			32 ⁽⁴⁾	V
BST_x to PGND_x			43 ⁽⁴⁾	V
Input clamp current, I _{IK}			±20	mA
Output clamp current, I _{OK}			±20	mA
Operating free-air temperature		0	85	°C
Operating junction temperature		0	150	°C
Storage temperature, T _{stg}		-40	125	°C

- (1) Stresses beyond those listed under *Absolute Maximum Ratings* may cause permanent damage to the device. These are stress ratings only and functional operation of the device at these or any other conditions beyond those indicated under *Recommended Operating Conditions* is not implied. Exposure to absolute-maximum conditions for extended periods may affect device reliability.
- (2) 5-V tolerant inputs are PDN, RESET, SCLK, LRCLK, MCLK, SDIN, SDA, and SCL.
- (3) Maximum pin voltage should not exceed 6 V.
- (4) DC voltage + peak ac waveform measured at the pin should be below the allowed limit for all conditions.

8.2 ESD Ratings

		VALUE	UNIT
V _(ESD) Electrostatic discharge	Human-body model (HBM), per ANSI/ESDA/JEDEC JS-001 ⁽¹⁾	±1000	V
	Charged-device model (CDM), per JEDEC specification JESD22-C101 ⁽²⁾	±250	

- (1) JEDEC document JEP155 states that 500-V HBM allows safe manufacturing with a standard ESD control process.
- (2) JEDEC document JEP157 states that 250-V CDM allows safe manufacturing with a standard ESD control process.

8.3 Recommended Operating Conditions

		MIN	NOM	MAX	UNIT
	Digital/analog supply voltage	DVDD, AVDD			V
	Half-bridge supply voltage	PVDD_x ⁽¹⁾			V
V _{IH}	High-level input voltage	5-V tolerant			V
V _{IL}	Low-level input voltage	5-V tolerant			V
T _A	Operating ambient temperature	0	85		°C
T _J ⁽²⁾	Operating junction temperature	0	125		°C
R _L (BTL)	Load impedance	Output filter: L = 15 μH, C = 680 nF			Ω
R _L (PBTL)	Load impedance	Output filter: L = 15 μH, C = 680 nF			Ω
L _O (BTL)	Output-filter inductance	Minimum output inductance under short-circuit condition			μH
	Output sample rate	11.025/22.05/44.1-kHz data rate ±2%			kHz
		48/24/12/8/16/32-kHz data rate ±2%			

- (1) For operation at PVDD_x levels greater than 18 V, the modulation limit must be set to 93.8% through the control port register 0x10.
- (2) Continuous operation above the recommended junction temperature may result in reduced reliability and/or lifetime of the device.

8.4 Thermal Information

THERMAL METRIC ⁽¹⁾		TAS5727	
		PHP (HTQFP)	
		48 PINS	
Symbol	Description	Value	UNIT
$R_{\theta JA}$	Junction-to-ambient thermal resistance	27.9	°C/W
$R_{\theta JC(top)}$	Junction-to-case (top) thermal resistance	13	°C/W
$R_{\theta JB}$	Junction-to-board thermal resistance	1.1	°C/W
Ψ_{JT}	Junction-to-top characterization parameter	20.7	°C/W
Ψ_{JB}	Junction-to-board characterization parameter	0.3	°C/W
$R_{\theta JC(bot)}$	Junction-to-case (bottom) thermal resistance	6.7	°C/W

(1) For more information about traditional and new thermal metrics, see the [Semiconductor and IC Package Thermal Metrics](#) application report.

8.5 DC Electrical Characteristics

$T_A = 25^\circ$, $PVCC_X = 18$ V, $DVDD = AVDD = 3.3$ V, $R_L = 8$ Ω , BTL AD mode, $f_s = 48$ kHz (unless otherwise noted)

PARAMETER			TEST CONDITIONS	MIN	TYP	MAX	UNIT
V_{OH}	High-level output voltage	A_SEL_ \overline{FAULT} and SDA	$I_{OH} = -4$ mA DVDD = 3 V	2.4			V
V_{OL}	Low-level output voltage	A_SEL_ \overline{FAULT} and SDA	$I_{OL} = 4$ mA DVDD = 3 V			0.5	V
I_{IL}	Low-level input current		$V_I < V_{IL}$; DVDD = AVDD = 3.6 V			75	μ A
I_{IH}	High-level input current		$V_I > V_{IH}$; DVDD = AVDD = 3.6 V			75 ⁽¹⁾	μ A
I_{DD}	3.3-V supply current	3.3-V supply voltage (DVDD, AVDD)	Normal mode		49	68	mA
			Reset ($\overline{RESET} = \text{low}$, PDN = high)		23	38	
I_{PVDD}	Supply current	No load (PVDD_X)	Normal mode		32	50	mA
			Reset ($\overline{RESET} = \text{low}$, PDN = high)		3	8	
$r_{DS(on)}$ (2)	Drain-to-source resistance, LS	$T_J = 25^\circ\text{C}$, includes metallization resistance			75		m Ω
	Drain-to-source resistance, HS	$T_J = 25^\circ\text{C}$, includes metallization resistance			75		
I/O Protection							
V_{UVP}	Undervoltage protection limit	PVDD falling			7.2		V
$V_{UVP,hyst}$	Undervoltage protection limit	PVDD rising			7.6		V
OTE ⁽³⁾	Overtemperature error				150		°C
OTE _{HYST} ⁽³⁾	Extra temperature drop required to recover from error				30		°C
I_{OC}	Overcurrent limit protection				4.5		A
I_{OCT}	Overcurrent response time				150		ns
R_{PD}	Internal pulldown resistor at the output of each half-bridge	Connected when drivers are in the high-impedance state to provide bootstrap capacitor charge.			3		k Ω

(1) I_{IH} for the PBTL pin has a maximum limit of 200 μ A due to an internal pulldown on the pin.

(2) This does not include bond-wire or pin resistance.

(3) Specified by design

8.6 AC Electrical Characteristics (BTL, PBTL)

PVDD_x = 18 V, BTL AD mode, $f_S = 48$ KHz, $R_L = 8 \Omega$, $R_{OCP} = 22$ k Ω , $C_{BST} = 33$ nF, audio frequency = 1 kHz, AES17 filter, $f_{PWM} = 384$ kHz, $T_A = 25^\circ\text{C}$ (unless otherwise specified). All performance is in accordance with recommended operating conditions (unless otherwise specified).

PARAMETER		TEST CONDITIONS	MIN	TYP	MAX	UNIT
P _O	Power output per channel	PVDD = 18 V, 10% THD, 1-kHz input signal		21.5		W
		PVDD = 18 V, 7% THD, 1-kHz input signal		20.3		
		PVDD = 12 V, 10% THD, 1-kHz input signal		9.6		
		PVDD = 12 V, 7% THD, 1-kHz input signal		9.1		
		PVDD = 8 V, 10% THD, 1-kHz input signal		4.2		
		PVDD = 8 V, 7% THD, 1-kHz input signal		4		
		PBTL mode, PVDD = 12 V, $R_L = 4 \Omega$, 10% THD, 1-kHz input signal		18.7		
		PBTL mode, PVDD = 12 V, $R_L = 4 \Omega$, 7% THD, 1-kHz input signal		17.7		
		PBTL mode, PVDD = 18 V, $R_L = 4 \Omega$, 10% THD, 1-kHz input signal		41.5		
		PBTL mode, PVDD = 18 V, $R_L = 4 \Omega$, 7% THD, 1-kHz input signal		39		
THD+N	Total harmonic distortion + noise	PVDD = 18 V, P _O = 1 W		0.07%		
		PVDD = 12 V, P _O = 1 W		0.03%		
		PVDD = 8 V, P _O = 1 W		0.1%		
V _n	Output integrated noise (rms)	A-weighted		56		μV
	Crosstalk	P _O = 0.25 W, f = 1 kHz (BD Mode)		-82		dB
		P _O = 0.25 W, f = 1 kHz (AD Mode)		-69		dB
SNR	Signal-to-noise ratio ⁽¹⁾	A-weighted, f = 1 kHz, maximum power at THD < 1%		106		dB

(1) SNR is calculated relative to 0-dBFS input level.

8.7 PLL Input Parameters and External Filter Components

PARAMETER		TEST CONDITIONS	MIN	TYP	MAX	UNIT
f _{MCLKI}	MCLK frequency		2.8224		24.576	MHz
	MCLK duty cycle		40%	50%	60%	
t _r / t _{f(MCLK)}	Rise/fall time for MCLK				5	ns
	LRCLK allowable drift before LRCLK reset				4	MCLKs
	External PLL filter capacitor C1	SMD 0603 X7R		47		nF
	External PLL filter capacitor C2	SMD 0603 X7R		4.7		nF
	External PLL filter resistor R	SMD 0603, metal film		470		Ω

8.8 Serial Audio Ports Slave Mode

over recommended operating conditions (unless otherwise noted)

PARAMETER		TEST CONDITIONS	MIN	NOM	MAX	UNIT
f _{SCLKIN}	Frequency, SCLK $32 \times f_S$, $48 \times f_S$, $64 \times f_S$	C _L = 30 pF	1.024		12.288	MHz
t _{su1}	Setup time, LRCLK to SCLK rising edge		10			ns
t _{h1}	Hold time, LRCLK from SCLK rising edge		10			ns
t _{su2}	Setup time, SDIN to SCLK rising edge		10			ns
t _{h2}	Hold time, SDIN from SCLK rising edge		10			ns
	LRCLK frequency		8	48	48	kHz
	SCLK duty cycle		40%	50%	60%	
	LRCLK duty cycle		40%	50%	60%	

Serial Audio Ports Slave Mode (continued)

over recommended operating conditions (unless otherwise noted)

PARAMETER	TEST CONDITIONS	MIN	NOM	MAX	UNIT
	SCLK rising edges between LRCLK rising edges	32		64	SCLK edges
$t_{(edge)}$	LRCLK clock edge with respect to the falling edge of SCLK	-1/4		1/4	SCLK period
t_r/t_f	Rise/fall time for SCLK/LRCLK			8	ns

8.9 I²C Serial Control Port Operation

Timing characteristics for I²C Interface signals over recommended operating conditions (unless otherwise noted)

PARAMETER	TEST CONDITIONS	MIN	MAX	UNIT
f_{SCL} Frequency, SCL	No wait states		400	kHz
$t_{w(H)}$ Pulse duration, SCL high		0.6		μ s
$t_{w(L)}$ Pulse duration, SCL low		1.3		μ s
t_r Rise time, SCL and SDA			300	ns
t_f Fall time, SCL and SDA			300	ns
t_{su1} Setup time, SDA to SCL		100		ns
t_{h1} Hold time, SCL to SDA		0		ns
$t_{(buf)}$ Bus free time between stop and start conditions		1.3		μ s
t_{su2} Setup time, SCL to start condition		0.6		μ s
t_{h2} Hold time, start condition to SCL		0.6		μ s
t_{su3} Setup time, SCL to stop condition		0.6		μ s
C_L Load capacitance for each bus line			400	pF

8.10 Reset Timing (RESET)

Control signal parameters over recommended operating conditions (unless otherwise noted). Please refer to Recommended Use Model section on usage of all terminals.

PARAMETER	MIN	NOM	MAX	UNIT
$t_{w(RESET)}$ Pulse duration, RESET active	100			μ s
$t_{d(I2C_ready)}$ Time to enable I ² C			12	ms

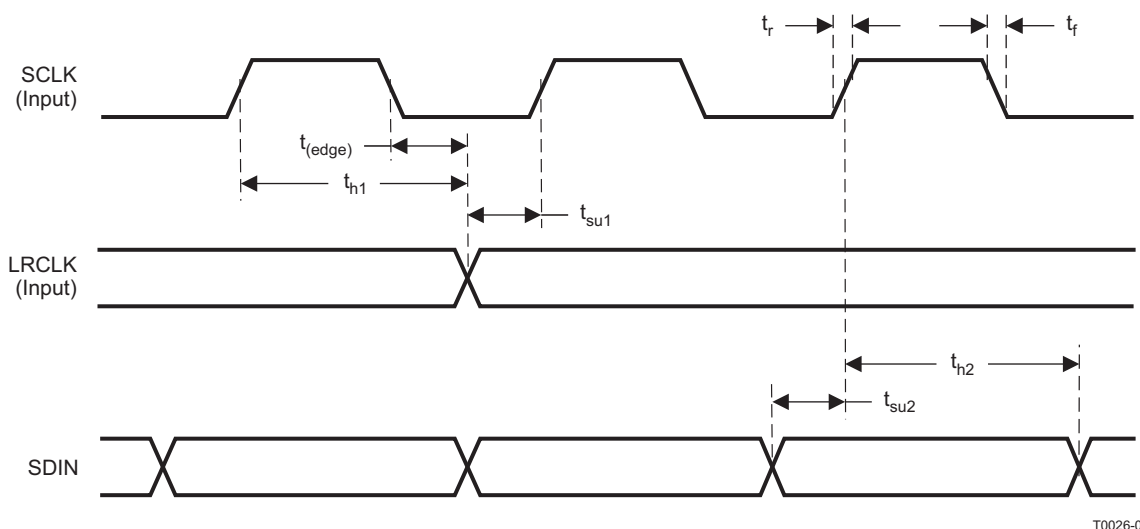
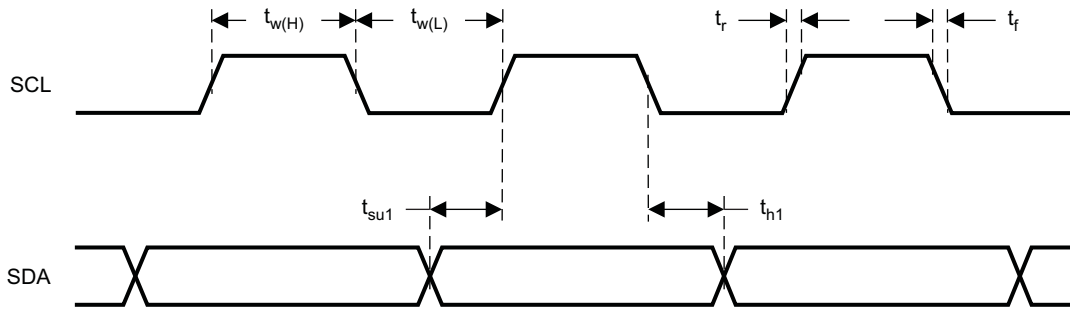
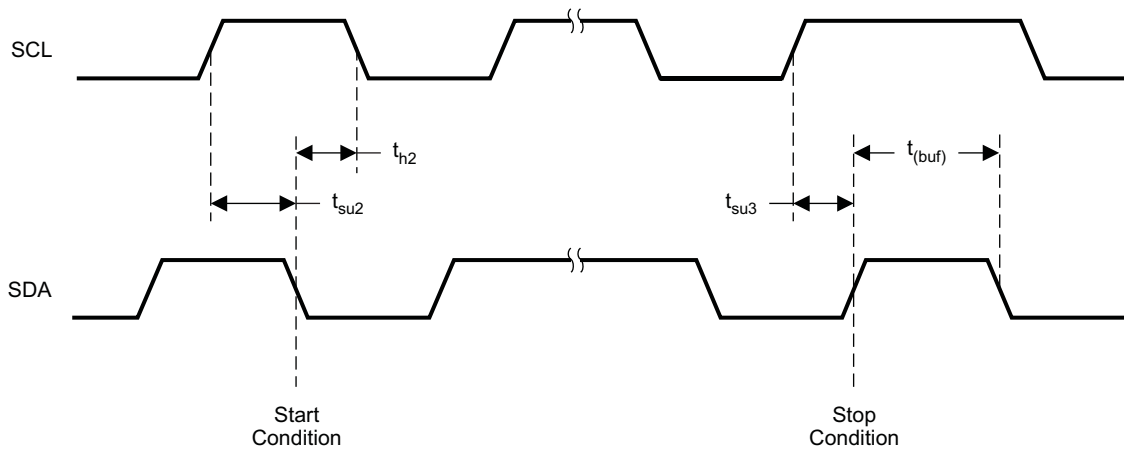

Figure 1. Slave-Mode Serial Data-Interface Timing



T0027-01

Figure 2. SCL and SDA Timing



T0028-01

Figure 3. Start and Stop Conditions Timing

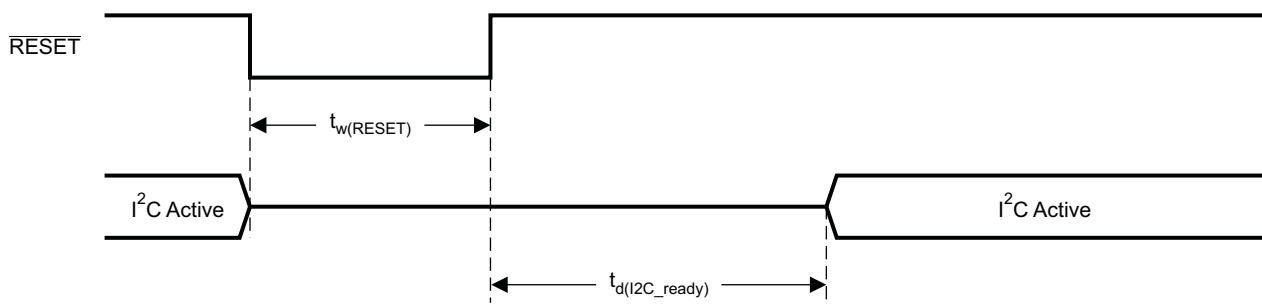

System Initialization.
Enable via I²C.

T0421-01

NOTES: On power up, TI recommends that the TAS5727 \overline{RESET} be held LOW for at least 100 μ s after DVDD has reached 3 V.

If \overline{RESET} is asserted LOW while \overline{PDN} is LOW, then \overline{RESET} must continue to be held LOW for at least 100 μ s after \overline{PDN} is deasserted (HIGH).

Figure 4. Reset Timing

8.11 Typical Characteristics

BTL Configuration, 8 Ω

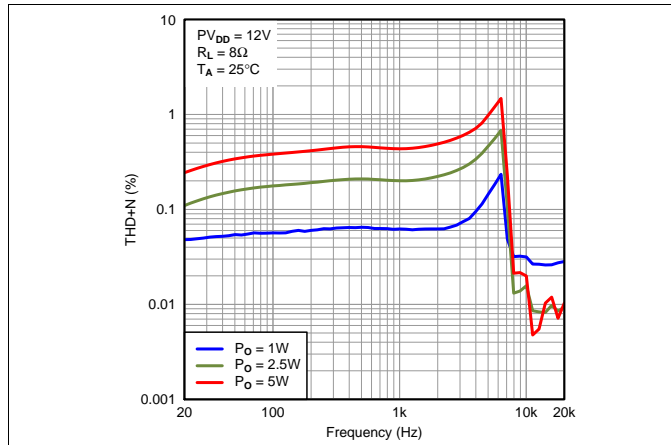

Figure 5. Total Harmonic Distortion + Noise vs Frequency

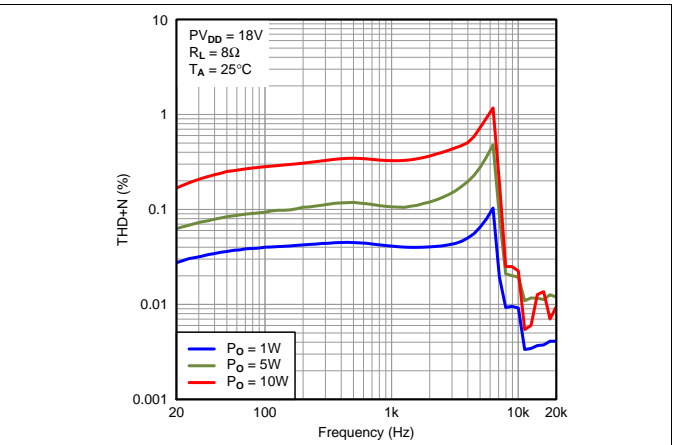

Figure 6. Total Harmonic Distortion + Noise vs Frequency

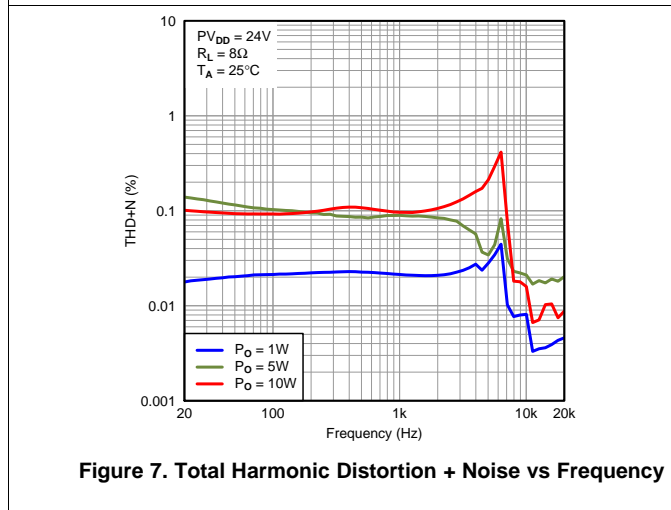

Figure 7. Total Harmonic Distortion + Noise vs Frequency

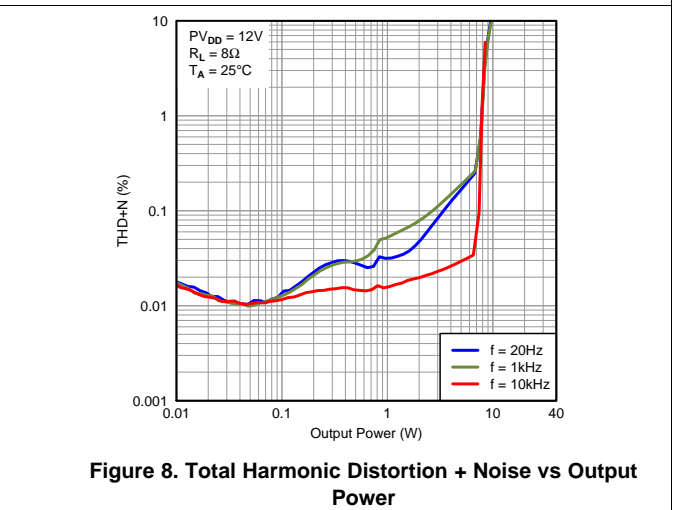

Figure 8. Total Harmonic Distortion + Noise vs Output Power

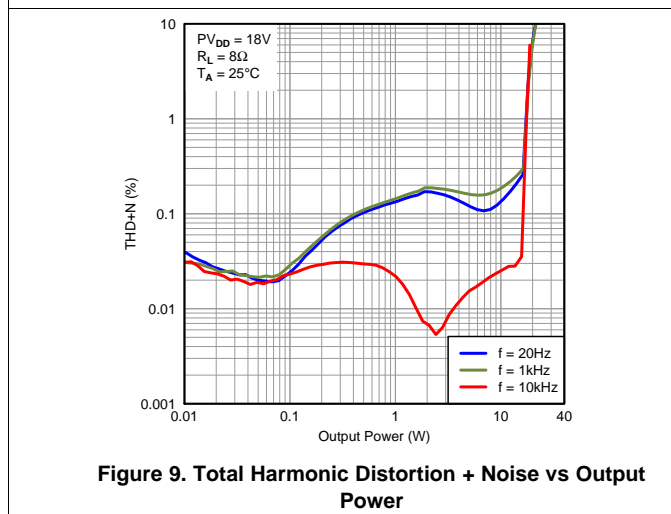

Figure 9. Total Harmonic Distortion + Noise vs Output Power

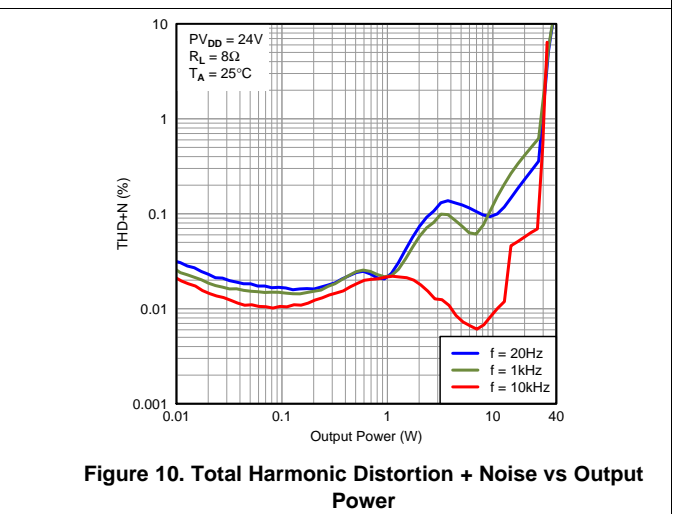
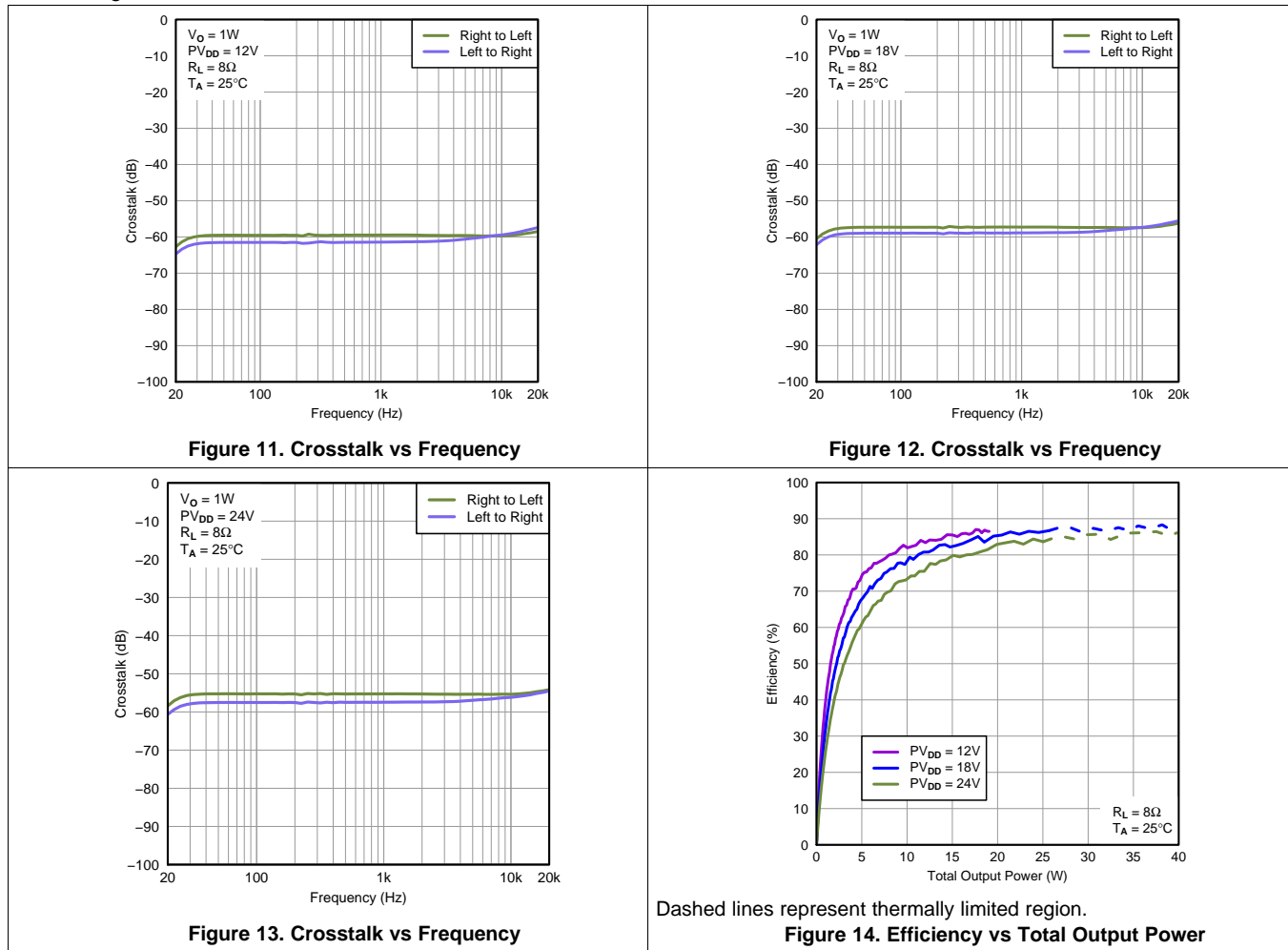

Figure 10. Total Harmonic Distortion + Noise vs Output Power

Typical Characteristics (continued)

BTL Configuration, 8 Ω



9 Parameter Measurement Information

All parameters are measured according to the conditions described in the [Specifications](#).

10 Detailed Description

10.1 Overview

The TAS5727 is an efficient stereo I²S input Class-D audio power amplifier with a digital audio processor. The digital audio processor of the device uses noise shaping and customized correction algorithms to achieve a great power efficiency and high audio performance. Also, the device has up to eighteen equalizers and two-band advanced Automatic Gain Limiting (AGL).

The device needs only a single DVDD supply in addition to the higher-voltage PVDD power supply. An internal voltage regulator provides suitable voltage levels for the gate drive circuit. The wide PVDD power supply range of the device enables its use in a multitude of applications.

The TAS5727 is a slave-only device that is controlled by a bidirectional I²C interface that supports both 100-kHz and 400-kHz data transfer rates for single- and multiple-byte write and read operations. This control interface is used to program the registers of the device and read the device status. The PWM of this device operates with a carrier frequency between 384 kHz and 354 kHz, depending the sampling rate. This device allows the use of the same clock signal for both MCLK and BCLK (64xFs) when using a sampling frequency of 44.1 kHz or 48 kHz.

This amplifier can be configured in two different modes, stereo and mono single filter configuration is supported in mono mode.

10.2 Functional Block Diagrams

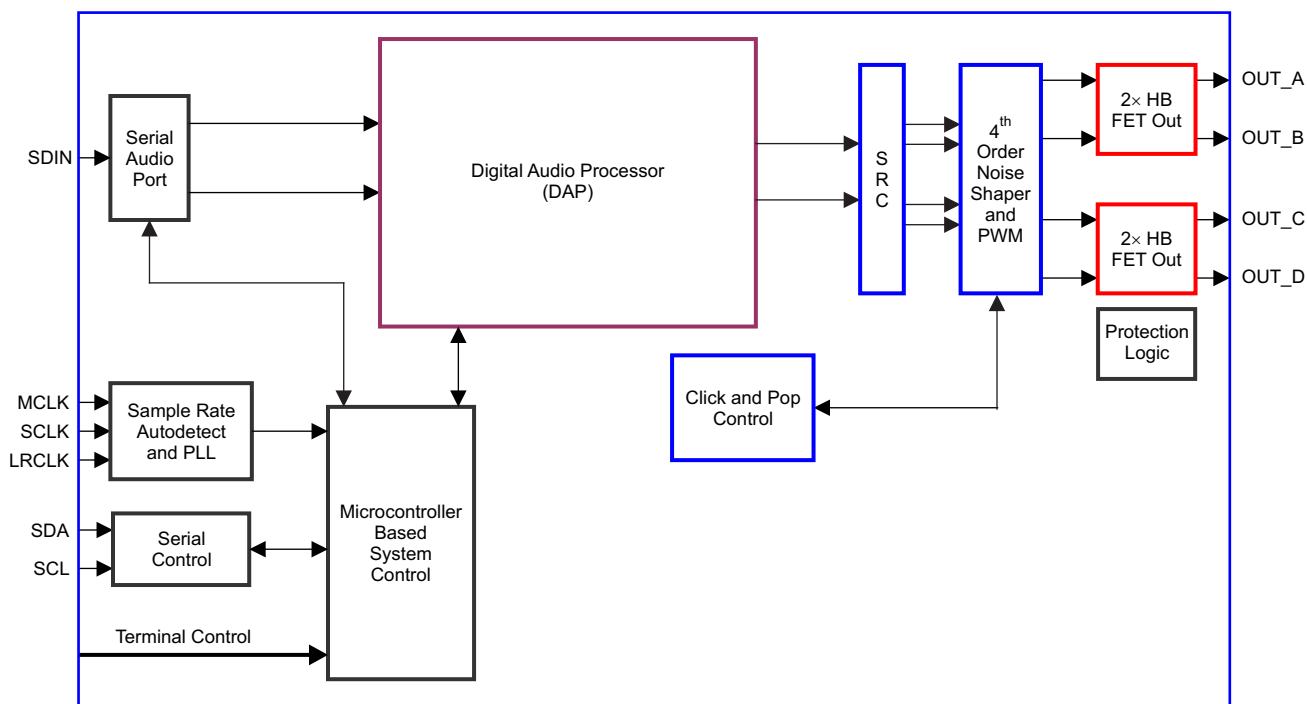

B0262-06

Copyright © 2016 Texas Instruments Incorporated

Figure 15. Functional View

Functional Block Diagrams (continued)

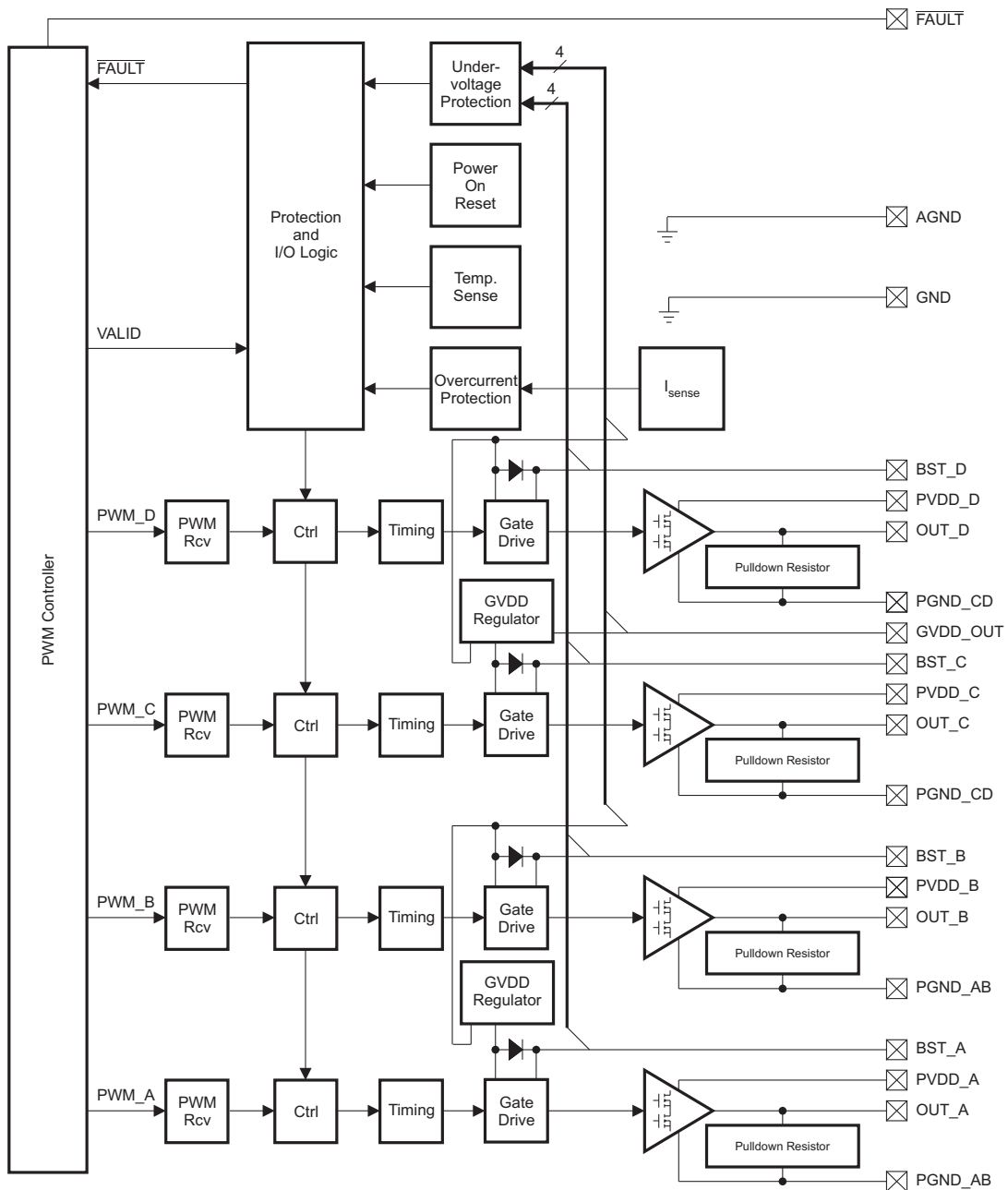

B0034-06
Copyright © 2016 Texas Instruments Incorporated

Figure 16. Power-Stage Functional Block Diagram

Functional Block Diagrams (continued)

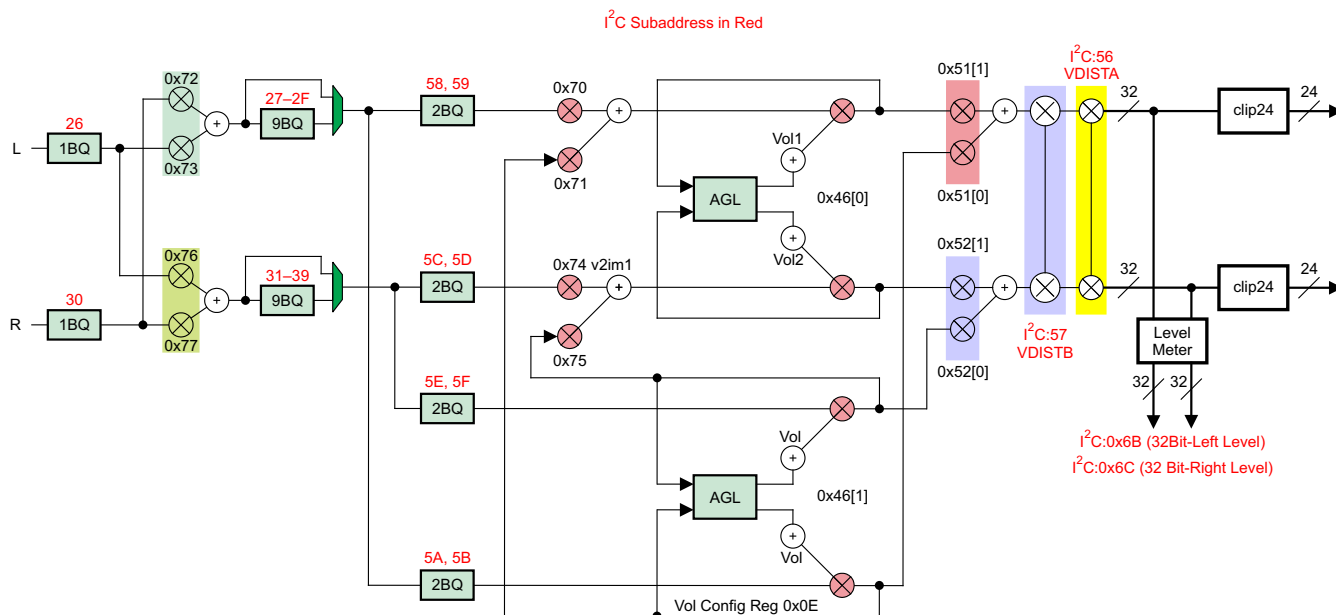

B0321-11
Copyright © 2016 Texas Instruments Incorporated

Figure 17. DAP Process Structure

10.3 Feature Description

10.3.1 Power Supply

To facilitate system design, the TAS5727 needs only a 3.3-V supply in addition to the (typical) 18-V power-stage supply. An internal voltage regulator provides suitable voltage levels for the gate drive circuitry. Additionally, all circuitry requiring a floating voltage supply, for example, the high-side gate drive, is accommodated by built-in bootstrap circuitry requiring only a few external capacitors.

To provide good electrical and acoustical characteristics, the PWM signal path for the output stage is designed as identical, independent half-bridges. For this reason, each half-bridge has separate bootstrap pins (BST_x), and power-stage supply pins (PVDD_x). The gate-drive voltage (GVDD_OUT) is derived from the PVDD voltage. Place all decoupling capacitors as close to their associated pins as possible. Inductance between the power-supply pins and decoupling capacitors must be avoided.

For a properly functioning bootstrap circuit, a small ceramic capacitor must be connected from each bootstrap pin (BST_x) to the power-stage output pin (OUT_x). When the power-stage output is low, the bootstrap capacitor is charged through an internal diode connected between the gate-drive regulator output pin (GVDD_OUT) and the bootstrap pin. When the power-stage output is high, the bootstrap capacitor potential is shifted above the output potential and thus provides a suitable voltage supply for the high-side gate driver. In an application with PWM switching frequencies in the range from 288 kHz to 384 kHz, TI recommends using 33-nF, X7R ceramic capacitors, size 0603 or 0805, for the bootstrap supply. These 33-nF capacitors ensure sufficient energy storage, even during minimal PWM duty cycles, to keep the high-side power-stage FET (LDMOS) fully turned on during the remaining part of the PWM cycle.

Pay special attention to the power-stage power supply; this includes component selection, PCB placement, and routing. As indicated, each half-bridge has independent power-stage supply pins (PVDD_x). For optimal electrical performance, EMI compliance, and system reliability, it is important that each PVDD_x pin is decoupled with a 100-nF, X7R ceramic capacitor placed as close as possible to each supply pin.

The TAS5727 is fully protected against erroneous power-stage turnon due to parasitic gate charging.

Feature Description (continued)

10.3.2 I²C Address Selection and Fault Output

10.3.2.1 I²C Chip Select

A_SEL_FAULT is an input pin during power up. It can be pulled high (15-kΩ pullup) or low (15-kΩ pulldown). High indicates an I²C subaddress of 0x56, and low a subaddress of 0x54.

10.3.2.2 I²C Device Address Change Procedure

- Write to device address change enable register, 0xF8 with a value of 0xF9A5 A5A5.
- Write to device register 0xF9 with a value of 0x0000 00XX, where XX is the new address.
- Any writes after that should use the new device address XX.

10.3.2.3 Fault Indication

A_SEL_FAULT is an input pin during power up. This pin can be programmed after RESET to be an output by writing 1 to bit 0 of I²C register 0x05. In that mode, the A_SEL_FAULT pin has the definition shown in Table 1.

Any fault resulting in device shutdown is signaled by the A_SEL_FAULT pin going low (see Table 1). A latched version of this pin is available on D1 of register 0x02. This bit can be reset only by an I²C write.

Table 1. A_SEL_FAULT Output States

A_SEL_FAULT	DESCRIPTION
0	Overcurrent (OC) or undervoltage (UVP) error or overtemperature error (OTE) or overvoltage error
1	No faults (normal operation)

10.3.3 Device Protection Systems

10.3.3.1 Overcurrent (OC) Protection With Current Limiting

The device has independent, fast-reacting current detectors on all high-side and low-side power-stage FETs. The detector outputs are closely monitored by two protection systems. The first protection system controls the power stage to prevent the output current further increasing, that is, the protection system performs a cycle-by-cycle current-limiting function, rather than prematurely shutting down during combinations of high-level music transients and extreme speaker load-impedance drops. If the high-current condition situation persists, that is, the power stage is being overloaded, a second protection system triggers a latching shutdown, resulting in the power stage being set in the high-impedance (Hi-Z) state. The device returns to normal operation once the fault condition (that is, a short circuit on the output) is removed. Current-limiting and overcurrent protection are not independent for half-bridges. That is, if the bridge-tied load between half-bridges A and B causes an overcurrent fault, half-bridges A, B, C, and D are shut down.

10.3.3.2 Overtemperature Protection

The TAS5727 has an overtemperature-protection system. If the device junction temperature exceeds 150°C (nominal), the device is put into thermal shutdown, resulting in all half-bridge outputs being set in the high-impedance (Hi-Z) state and A_SEL_FAULT being asserted low. The TAS5727 recovers automatically once the temperature drops approximately 30°C.

10.3.3.3 Undervoltage Protection (UVP) and Power-On Reset (POR)

The UVP and POR circuits of the TAS5727 fully protect the device in any power-up, power-down, and brownout situation. While powering up, the POR circuit resets the overload circuit (OLP) and ensures that all circuits are fully operational when the PVDD and AVDD supply voltages reach 7.6 V and 2.7 V, respectively. Although PVDD and AVDD are independently monitored, a supply-voltage drop below the UVP threshold on AVDD or either PVDD pin results in all half-bridge outputs immediately being set in the high-impedance (Hi-Z) state and A_SEL_FAULT being asserted low.

Feature Description (continued)

10.3.4 Clock, Auto Detection, and PLL

The TAS5727 is an I²S slave device. It accepts MCLK, SCLK, and LRCLK. The digital audio processor (DAP) supports all the sample rates and MCLK rates that are defined in the [Clock Control Register \(0x00\)](#).

The TAS5727 checks to verify that SCLK is a specific value of $32 f_s$, $48 f_s$, or $64 f_s$. The DAP only supports a $1 \times f_s$ LRCLK. The timing relationship of these clocks to SDIN is shown in subsequent sections. The clock section uses MCLK or the internal oscillator clock (when MCLK is unstable, out of range, or absent) to produce the internal clock (DCLK) running at 512 times the PWM switching frequency.

The DAP can autodetect and set the internal clock control logic to the appropriate settings for all supported clock rates as defined in the clock-control register.

The TAS5727 has robust clock error handling that uses the built-in trimmed oscillator clock to quickly detect changes and errors. Once the system detects a clock change or error, it mutes the audio (through a single-step mute) and then forces PLL to limp using the internal oscillator as a reference clock. Once the clocks are stable, the system autodetects the new rate and reverts to normal operation. During this process, the default volume is restored in a single step (also called hard unmute). The ramp process can be programmed to ramp back slowly (also called soft unmute) as defined in volume register (0x0E).

10.3.5 PWM Section

The TAS5727 DAP device uses noise-shaping and customized nonlinear correction algorithms to achieve high power efficiency and high-performance digital audio reproduction. The DAP uses a fourth-order noise shaper to increase dynamic range and SNR in the audio band. The PWM section accepts 24-bit PCM data from the DAP and outputs two BTL PWM audio output channels.

The PWM section has individual-channel DC-blocking filters that can be enabled and disabled. The filter cutoff frequency is less than 1 Hz. Individual-channel de-emphasis filters for 44.1 kHz and 48 kHz are included and can be enabled and disabled.

Finally, the PWM section has an adjustable maximum modulation limit of 93.8% to 99.2%.

For a detailed description of using audio processing features like DRC and EQ, see the User's Guide ([SLOU299](#)) and the [TAS57xx GDE](#).

10.3.6 SSTIMER Functionality

The SSTIMER pin uses a capacitor connected between this pin and ground to control the output duty cycle when exiting all-channel shutdown. The capacitor on the SSTIMER pin is slowly charged through an internal current source, and the charge time determines the rate at which the output transitions from a near-zero duty cycle to the desired duty cycle. This allows for a smooth transition that minimizes audible pops and clicks. When the part is shut down, the drivers are placed in the high-impedance state and transition slowly down through a 3-k Ω resistor, similarly minimizing pops and clicks. The shutdown transition time is independent of the SSTIMER pin capacitance. Larger capacitors increase the start-up time, while capacitors smaller than 2.2 nF decrease the start-up time. The SSTIMER pin should be left floating for BD modulation.

10.3.7 Single-Filter PBTL Mode

The TAS5727 supports parallel BTL (PBTL) mode with OUT_A/OUT_B (and OUT_C/OUT_D) connected before the LC filter. To put the part in PBTL configuration, drive PBTL (pin 8) HIGH. This synchronizes the turnoff of half-bridges A and B (and similarly C/D) if an overcurrent condition is detected in either half-bridge. There is a pulldown resistor on the PBTL pin that configures the part in BTL mode if the pin is left floating.

PWM output multiplexers should be updated to set the device in PBTL mode. Output Mux Register (0x25) should be written with a value of 0x0110 3245. Also, the PWM shutdown register (0x19) should be written with a value of 0x3A.

Feature Description (continued)

10.3.8 I²C Serial Control Interface

The TAS5727 DAP has a bidirectional I²C interface that is compatible with the Inter IC (I²C) bus protocol and supports both 100-kHz and 400-kHz data transfer rates for single- and multiple-byte write and read operations. This is a slave-only device that does not support a multimaster bus environment or wait-state insertion. The control interface is used to program the registers of the device and to read device status.

The DAP supports the standard-mode I²C bus operation (100 kHz maximum) and the fast I²C bus operation (400 kHz maximum). The DAP performs all I²C operations without I²C wait cycles.

10.3.8.1 General I²C Operation

The I²C bus employs two signals, SDA (data) and SCL (clock), to communicate between integrated circuits in a system. Data is transferred on the bus serially, one bit at a time. The address and data can be transferred in byte (8-bit) format, with the most-significant bit (MSB) transferred first. In addition, each byte transferred on the bus is acknowledged by the receiving device with an acknowledge bit. Each transfer operation begins with the master device driving a start condition on the bus and ends with the master device driving a stop condition on the bus. The bus uses transitions on the data pin (SDA) while the clock is high to indicate start and stop conditions. A high-to-low transition on SDA indicates a start and a low-to-high transition indicates a stop. Normal data-bit transitions must occur within the low time of the clock period. These conditions are shown in Figure 18. The master generates the 7-bit slave address and the read/write (R/W) bit to open communication with another device and then waits for an acknowledge condition. The TAS5727 holds SDA low during the acknowledge clock period to indicate an acknowledgment. When this occurs, the master transmits the next byte of the sequence. Each device is addressed by a unique 7-bit slave address plus R/W bit (1 byte). All compatible devices share the same signals through a bidirectional bus using a wired-AND connection. An external pullup resistor must be used for the SDA and SCL signals to set the high level for the bus.

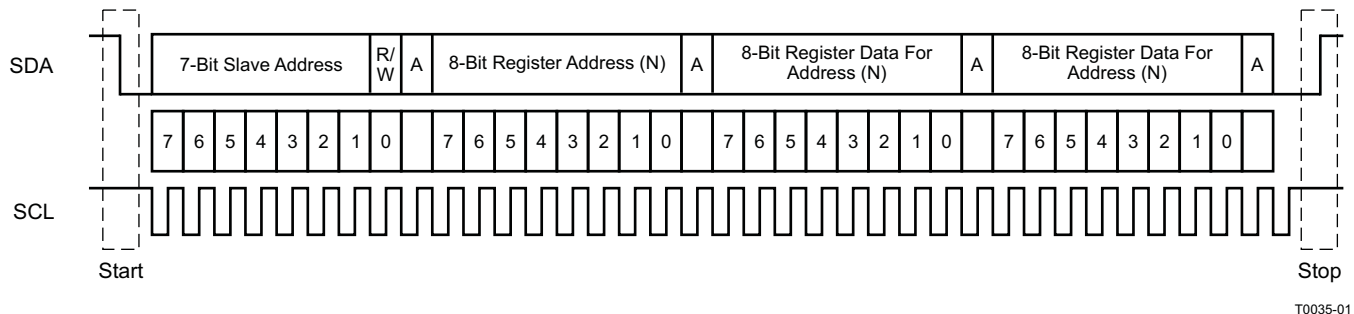

Figure 18. Typical I²C Sequence

There is no limit on the number of bytes that can be transmitted between start and stop conditions. When the last word transfers, the master generates a stop condition to release the bus. A generic data transfer sequence is shown in Figure 18.

The 7-bit address for TAS5715 is 0101 010 (0x54) or 0101 011 (0x56) defined by A_SEL (external pulldown for 0x54 and pullup for 0x56).

10.3.8.2 Single- and Multiple-Byte Transfers

The serial control interface supports both single-byte and multiple-byte read/write operations for subaddresses 0x00 to 0x1F. However, for the subaddresses 0x20 to 0xFF, the serial control interface supports only multiple-byte read/write operations (in multiples of 4 bytes).

During multiple-byte read operations, the DAP responds with data, a byte at a time, starting at the subaddress assigned, as long as the master device continues to respond with acknowledges. If a particular subaddress does not contain 32 bits, the unused bits are read as logic 0.

Feature Description (continued)

During multiple-byte write operations, the DAP compares the number of bytes transmitted to the number of bytes that are required for each specific subaddress. For example, if a write command is received for a biquad subaddress, the DAP must receive five 32-bit words. If fewer than five 32-bit data words have been received when a stop command (or another start command) is received, the received data is discarded.

Supplying a subaddress for each subaddress transaction is referred to as random I²C addressing. The TAS5727 also supports sequential I²C addressing. For write transactions, if a subaddress is issued followed by data for that subaddress and the 15 subaddresses that follow, a sequential I²C write transaction has taken place, and the data for all 16 subaddresses is successfully received by the TAS5727. For I²C sequential-write transactions, the subaddress then serves as the start address, and the amount of data subsequently transmitted, before a stop or start is transmitted, determines how many subaddresses are written. As was true for random addressing, sequential addressing requires that a complete set of data be transmitted. If only a partial set of data is written to the last subaddress, the data for the last subaddress is discarded. However, all other data written is accepted; only the incomplete data is discarded.

10.3.8.3 Single-Byte Write

As shown in Figure 19, a single-byte data-write transfer begins with the master device transmitting a start condition followed by the I²C device address and the read/write bit. The read/write bit determines the direction of the data transfer. For a data-write transfer, the read/write bit is a 0. After receiving the correct I²C device address and the read/write bit, the DAP responds with an acknowledge bit. Next, the master transmits the address byte or bytes corresponding to the TAS5727 internal memory address being accessed. After receiving the address byte, the TAS5727 again responds with an acknowledge bit. Next, the master device transmits the data byte to be written to the memory address being accessed. After receiving the data byte, the TAS5727 again responds with an acknowledge bit. Finally, the master device transmits a stop condition to complete the single-byte data-write transfer.

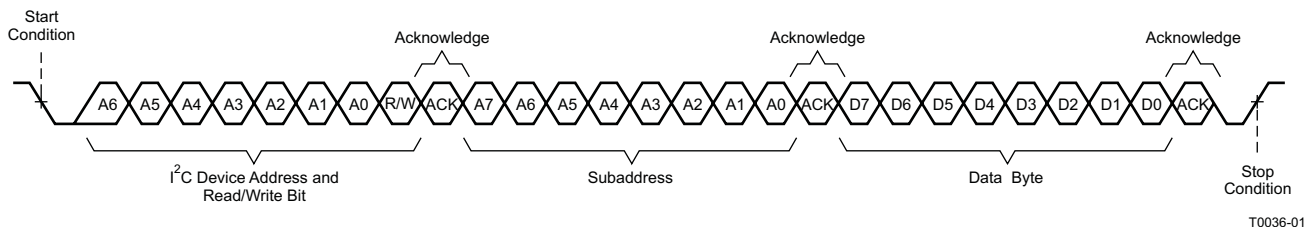

Figure 19. Single-Byte Write Transfer

10.3.8.4 Multiple-Byte Write

A multiple-byte data-write transfer is identical to a single-byte data-write transfer except that multiple data bytes are transmitted by the master device to the DAP as shown in Figure 20. After receiving each data byte, the TAS5727 responds with an acknowledge bit.

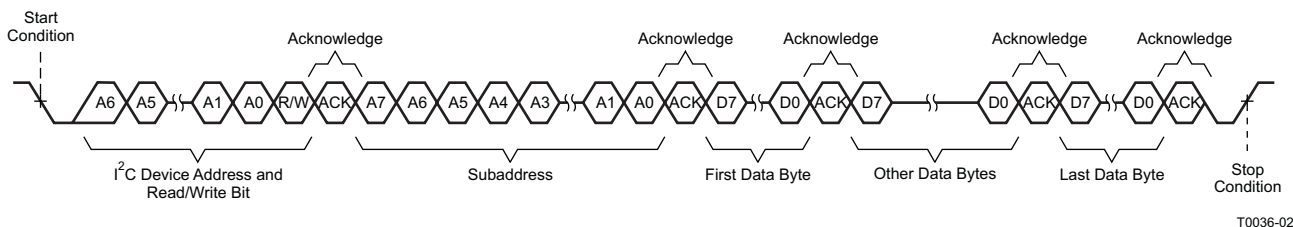

Figure 20. Multiple-Byte Write Transfer

Feature Description (continued)

10.3.8.5 Single-Byte Read

As shown in Figure 21, a single-byte data-read transfer begins with the master device transmitting a start condition, followed by the I²C device address and the read/write bit. For the data read transfer, both a write followed by a read are actually done. Initially, a write is done to transfer the address byte or bytes of the internal memory address to be read. As a result, the read/write bit becomes a 0. After receiving the TAS5727 address and the read/write bit, TAS5727 responds with an acknowledge bit. In addition, after sending the internal memory address byte or bytes, the master device transmits another start condition followed by the TAS5727 address and the read/write bit again. This time, the read/write bit becomes a 1, indicating a read transfer. After receiving the address and the read/write bit, the TAS5727 again responds with an acknowledge bit. Next, the TAS5727 transmits the data byte from the memory address being read. After receiving the data byte, the master device transmits a not-acknowledge followed by a stop condition to complete the single-byte data-read transfer.

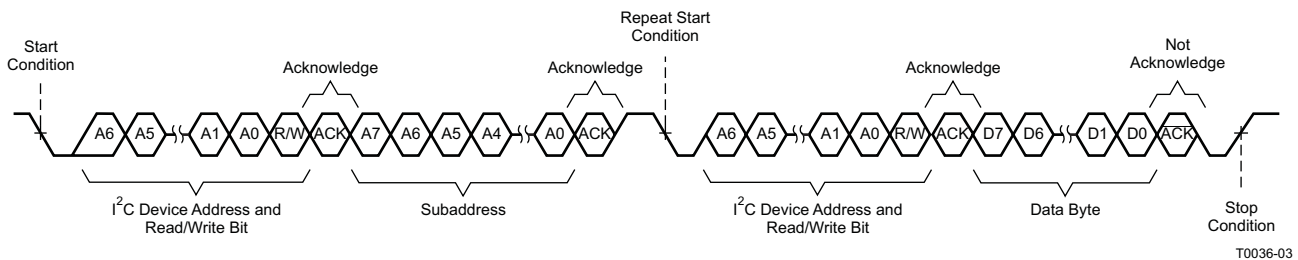

Figure 21. Single-Byte Read Transfer

10.3.8.6 Multiple-Byte Read

A multiple-byte data-read transfer is identical to a single-byte data-read transfer except that multiple data bytes are transmitted by the TAS5727 to the master device as shown in Figure 22. Except for the last data byte, the master device responds with an acknowledge bit after receiving each data byte.

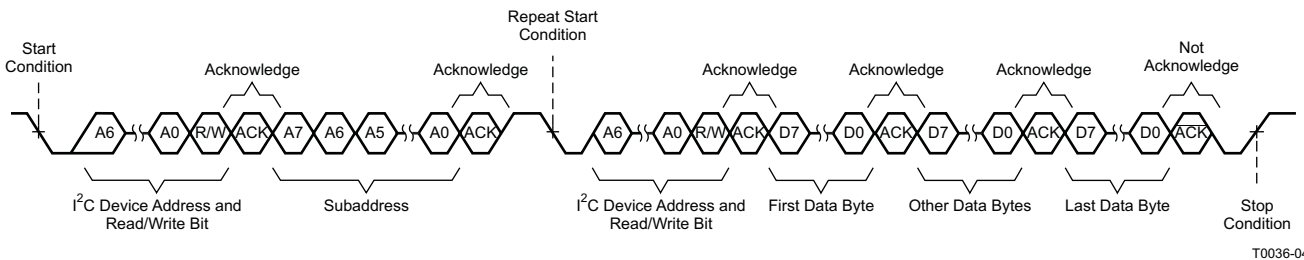

Figure 22. Multiple-Byte Read Transfer

10.3.9 Audio Serial Interface

Serial data is input on SDIN. The PWM outputs are derived from SDIN. The TAS5727 DAP accepts serial data in 16-, 20-, or 24-bit left-justified, right-justified, and I²S serial data formats.

10.3.10 Serial Interface Control and Timing

10.3.10.1 I²S Timing

I²S timing uses LRCLK to define when the data being transmitted is for the left channel and when it is for the right channel. LRCLK is low for the left channel and high for the right channel. A bit clock running at $32, 48, \text{ or } 64 \times f_s$ is used to clock in the data. There is a delay of one bit clock from the time the LRCLK signal changes state to the first bit of data on the data lines. The data is written MSB-first and is valid on the rising edge of bit clock. The DAP masks unused trailing data bit positions.

Feature Description (continued)

2-Channel I²S (Philips Format) Stereo Input

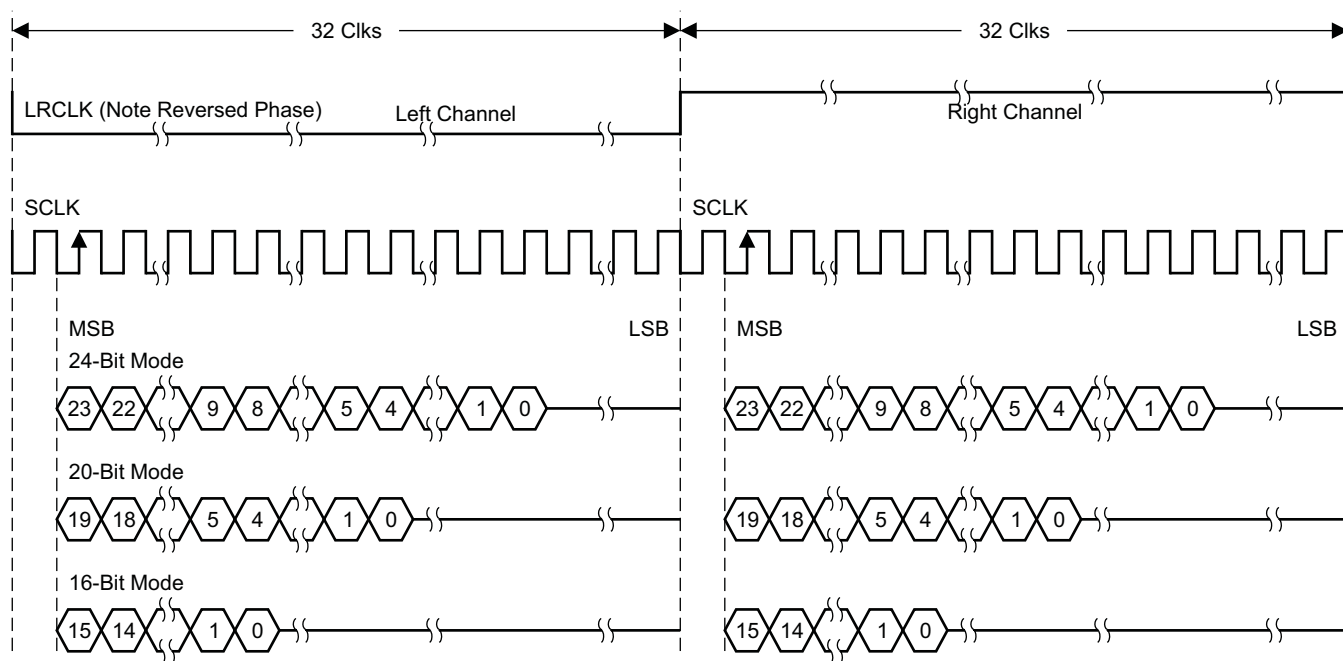

T0034-01

NOTE: All data presented in 2s-complement form with MSB first.

Figure 23. I²S 64-f_s Format

Feature Description (continued)

2-Channel I²S (Philips Format) Stereo Input/Output (24-Bit Transfer Word Size)

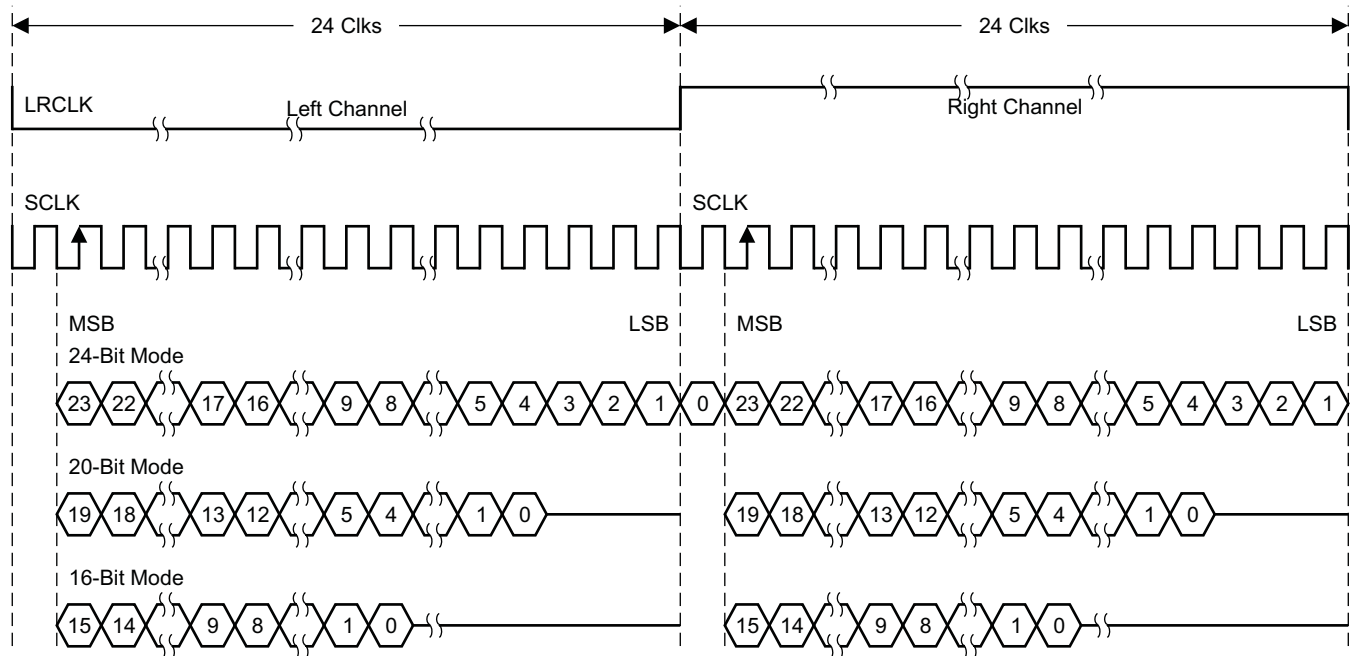

T0092-01

NOTE: All data presented in 2s-complement form with MSB first.

Figure 24. I²S 48-f_s Format

2-Channel I²S (Philips Format) Stereo Input

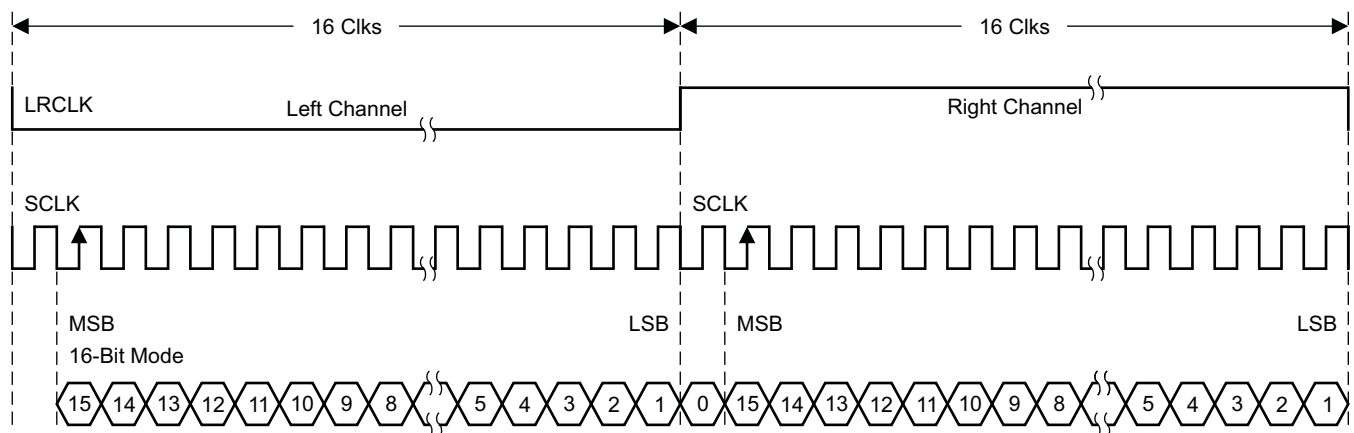

T0266-01

NOTE: All data presented in 2s-complement form with MSB first.

Figure 25. I²S 32-f_s Format

Feature Description (continued)

10.3.10.2 Left-Justified

Left-justified (LJ) timing uses LRCLK to define when the data being transmitted is for the left channel and when it is for the right channel. LRCLK is high for the left channel and low for the right channel. A bit clock running at 32 , 48 , or $64 \times f_s$ is used to clock in the data. The first bit of data appears on the data lines at the same time LRCLK toggles. The data is written MSB-first and is valid on the rising edge of the bit clock. The DAP masks unused trailing data bit positions.

2-Channel Left-Justified Stereo Input

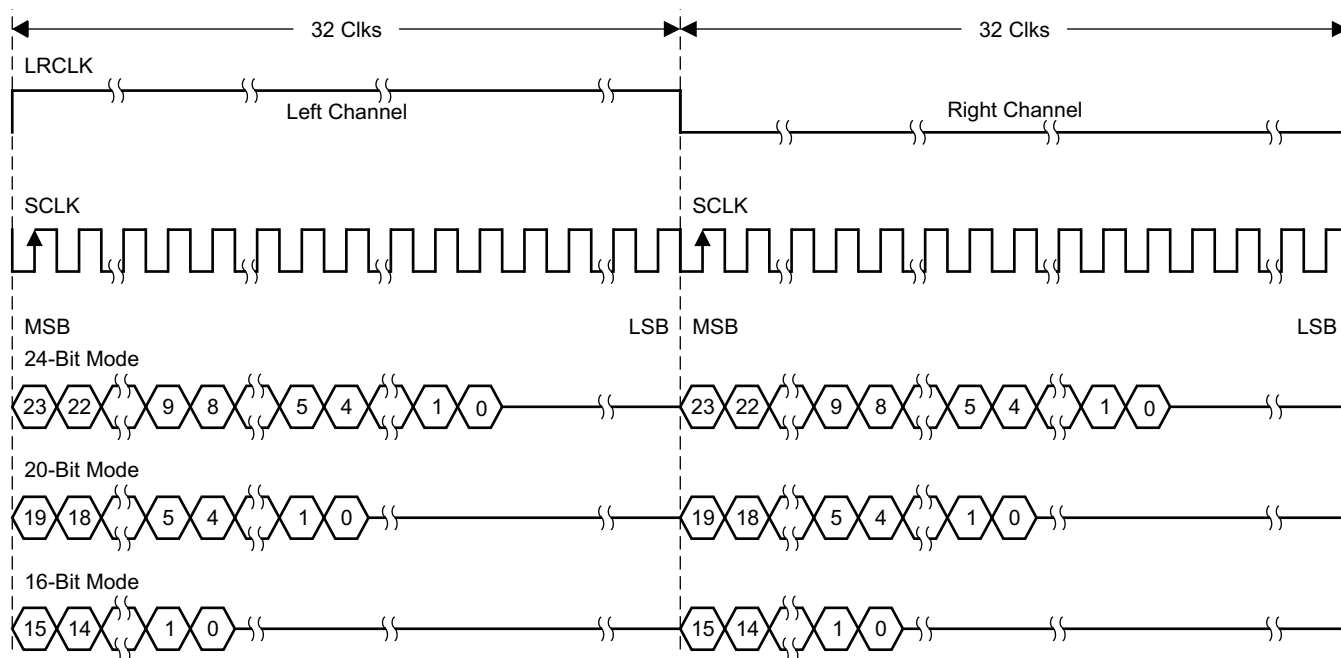

T0034-02

NOTE: All data presented in 2s-complement form with MSB first.

Figure 26. Left-Justified 64- f_s Format

Feature Description (continued)

2-Channel Left-Justified Stereo Input (24-Bit Transfer Word Size)

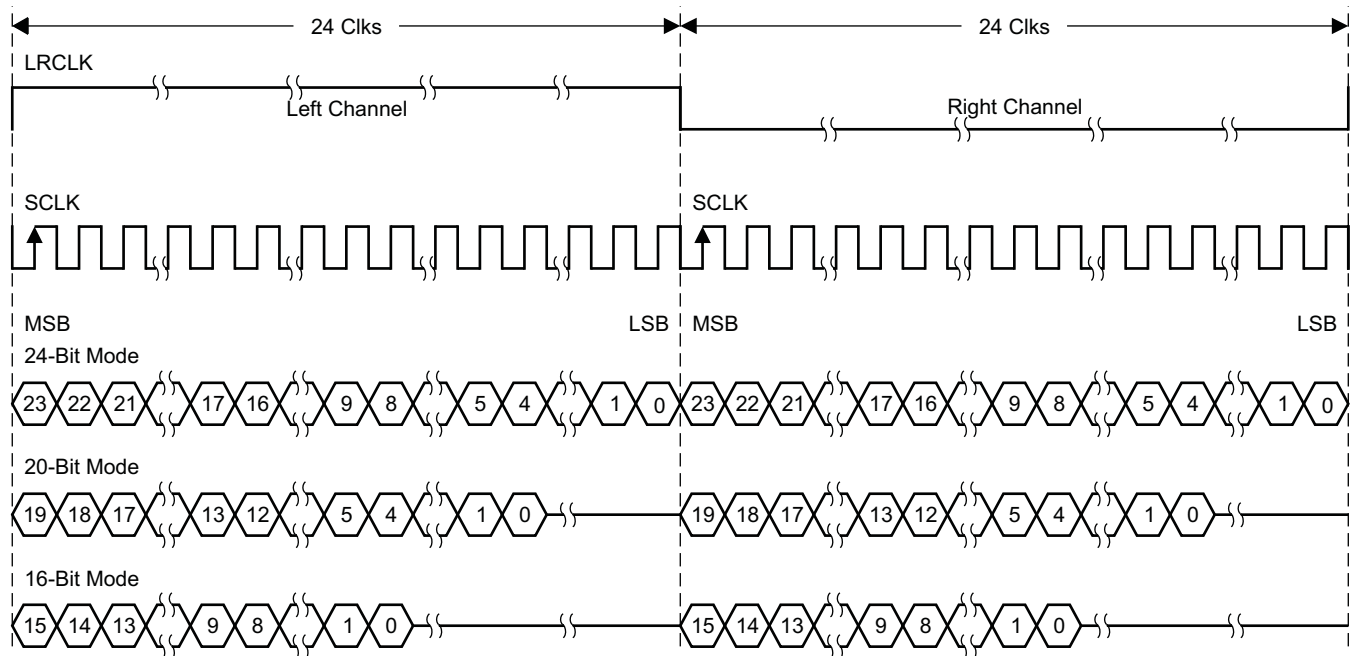

T0092-02

NOTE: All data presented in 2s-complement form with MSB first.

Figure 27. Left-Justified 48-f_s Format

2-Channel Left-Justified Stereo Input

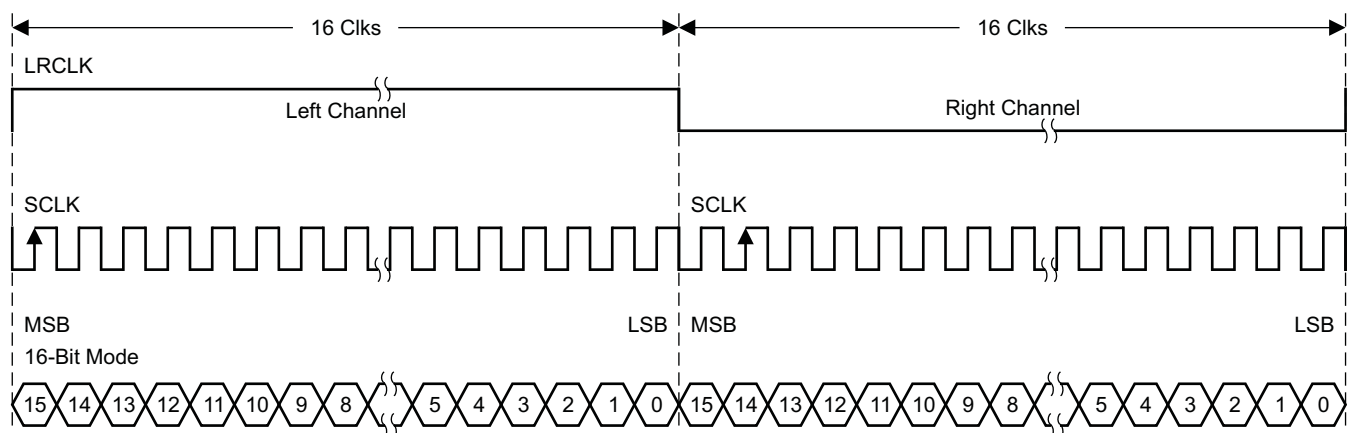

T0266-02

NOTE: All data presented in 2s-complement form with MSB first.

Figure 28. Left-Justified 32-f_s Format

Feature Description (continued)

10.3.10.3 Right-Justified

Right-justified (RJ) timing uses LRCLK to define when the data being transmitted is for the left channel and when it is for the right channel. LRCLK is high for the left channel and low for the right channel. A bit clock running at $32, 48, \text{ or } 64 \times f_s$ is used to clock in the data. The first bit of data appears on the data 8 bit-clock periods (for 24-bit data) after LRCLK toggles. In RJ mode, the LSB of data is always clocked by the last bit clock before LRCLK transitions. The data is written MSB-first and is valid on the rising edge of bit clock. The DAP masks unused leading data bit positions.

2-Channel Right-Justified (Sony Format) Stereo Input

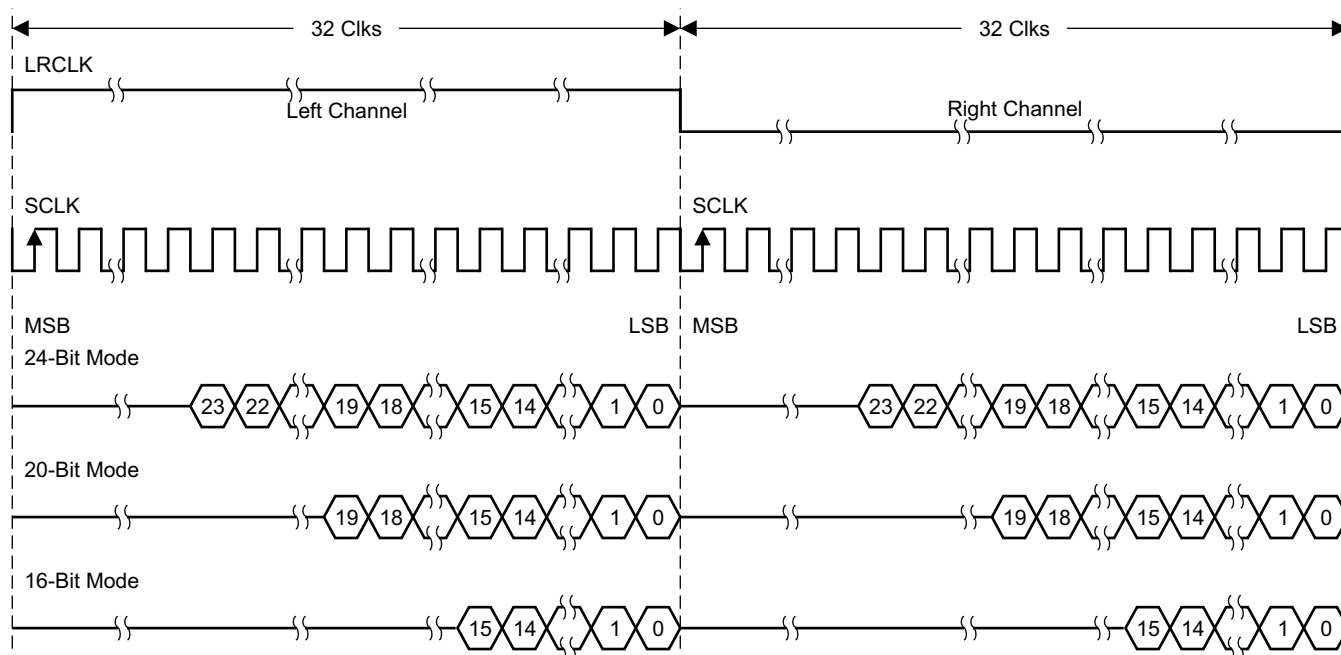

T0034-03

Figure 29. Right-Justified 64- f_s Format

Feature Description (continued)

2-Channel Right-Justified Stereo Input (24-Bit Transfer Word Size)

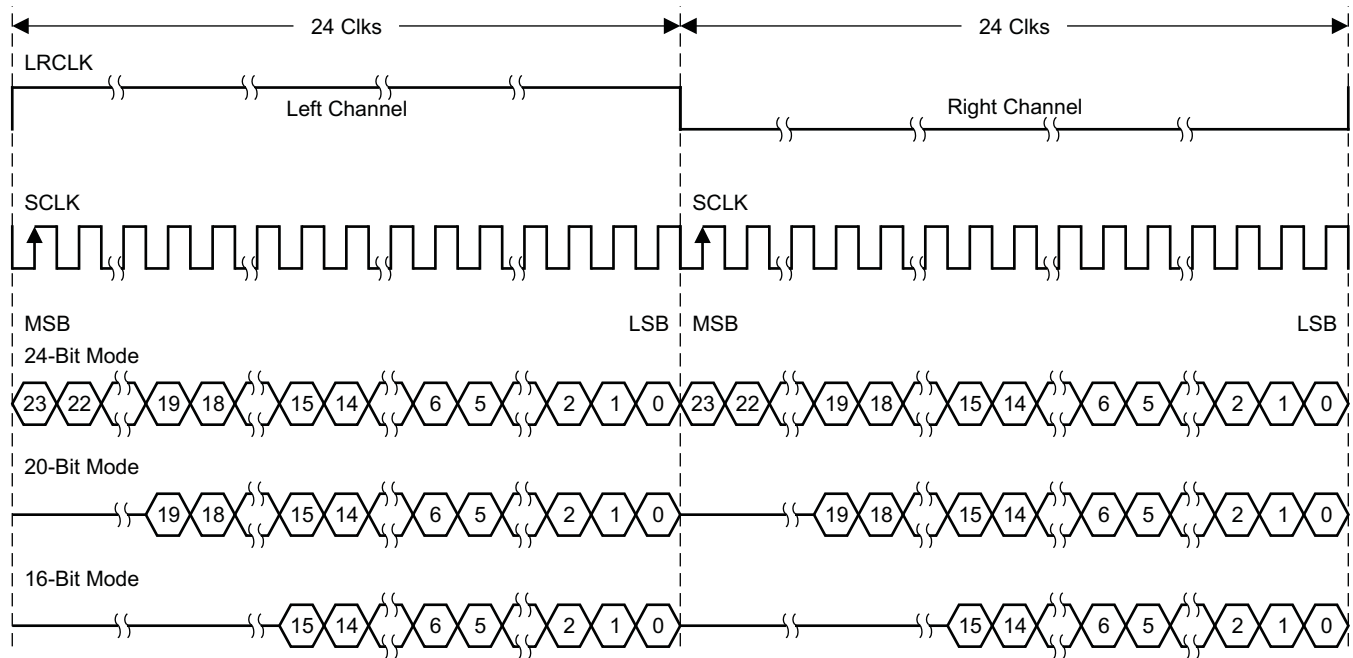

T0092-03

Figure 30. Right-Justified 48- f_s Format

2-Channel Right-Justified (Sony Format) Stereo Input

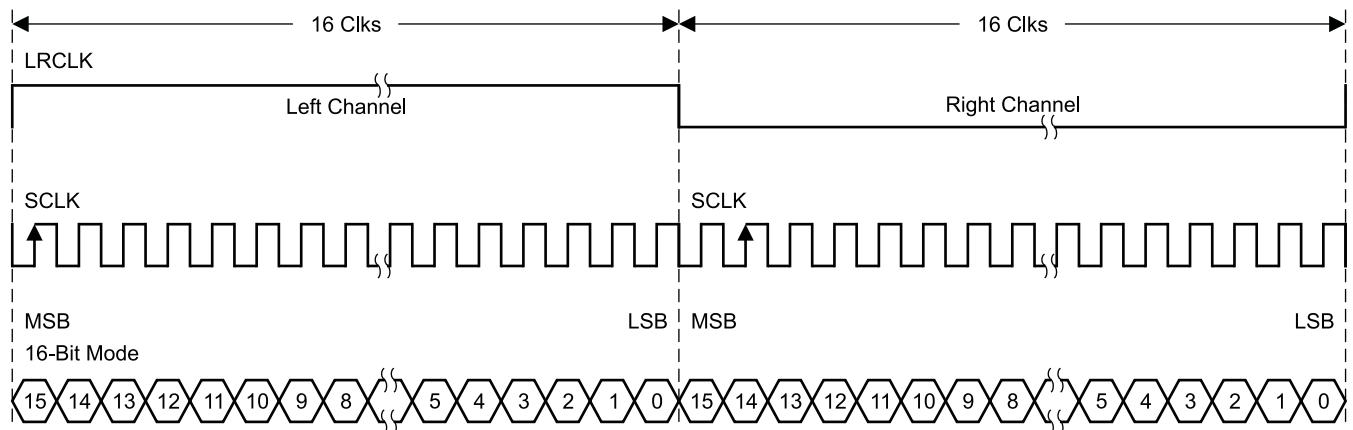

T0266-03

Figure 31. Right-Justified 32- f_s Format

10.3.11 Dynamic Range Control (DRC)

The DRC scheme has two DRC blocks. There is one ganged DRC for the high-band left and right channels and one DRC for the low-band left and right channels.

The DRC input/output diagram is shown in [Figure 32](#).

Feature Description (continued)

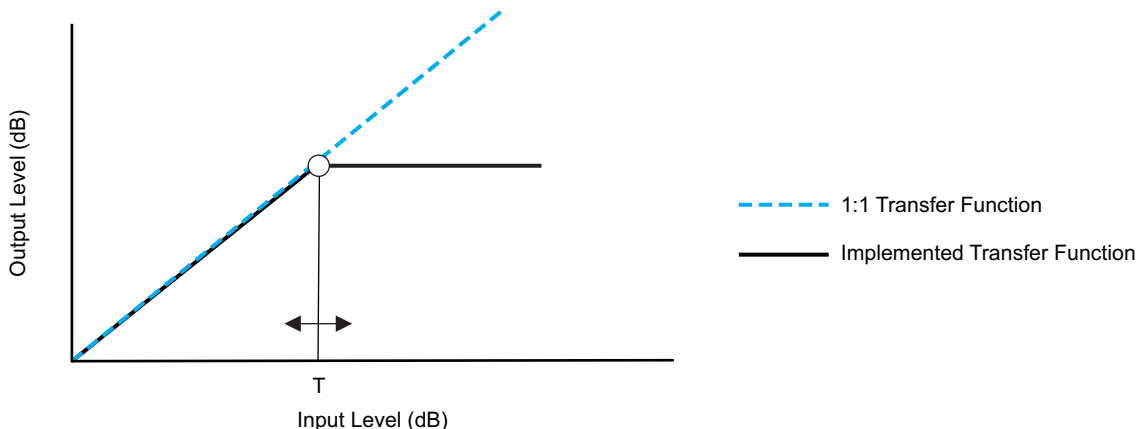

M0091-04

Professional-quality dynamic range compression automatically adjusts volume to flatten volume level.

- Each DRC has adjustable threshold levels.
- Programmable attack and decay time constants
- *Transparent compression*: compressors can attack fast enough to avoid apparent clipping before engaging, and decay times can be set slow enough to avoid pumping.

Figure 32. Dynamic Range Control

	α, ω	T	$\alpha_a, \omega_a / \alpha_d, \omega_d$
DRC1	0x3C	0x3B	0x40
DRC2	0x3F	0x3E	0x43

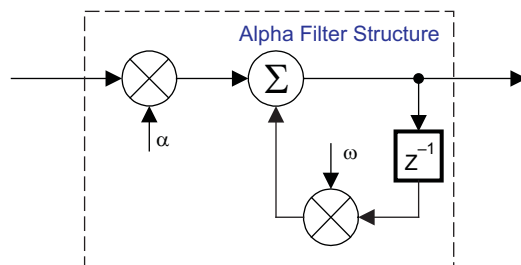

B0265-04

T = 9.23 format, all other DRC coefficients are 3.23 format

Figure 33. DRC Structure

10.3.12 PWM Level Meter

The structure in Figure 34 shows the PWM level meter that can be used to study the power profile.

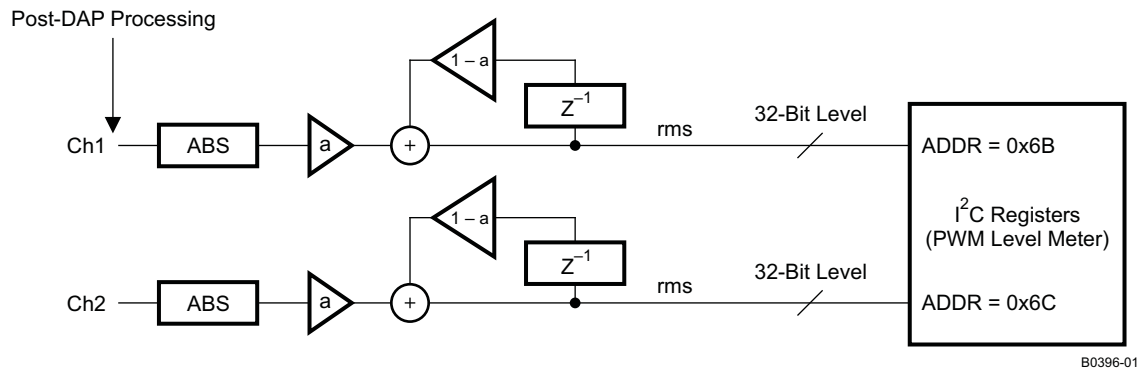
Feature Description (continued)

Figure 34. PWM Level Meter Structure
10.4 Device Functional Modes
10.4.1 Stereo BTL Mode

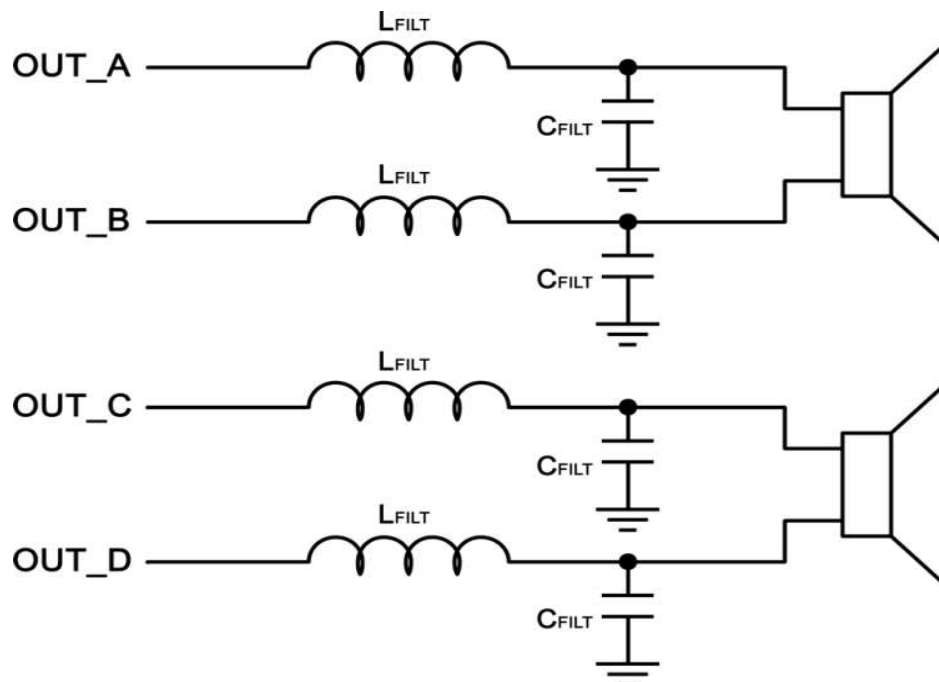
The classic stereo mode of operation uses the TAS5727 device to amplify two independent signals, which represent the left and right portions of a stereo signal. These amplified left and right audio signals are presented on differential output pairs shown as OUT_A and OUT_B for a channel and OUT_C and OUT_D for the other one. The routing of the audio data which is presented on the OUT_x outputs can be changed according to the PWM Output Mux Register (0x25). By default, the TAS5727 device is configured to output channel 1 to the OUT_A and OUT_B outputs, and channel 2 to the OUT_C and OUT_D outputs. Stereo Mode operation outputs are shown in [Figure 35](#).

Figure 35. Stereo BTL Mode

Device Functional Modes (continued)

10.4.2 Mono PBTL Mode

When this mode of operation is used, the two stereo outputs of the device are placed in parallel one with another to increase the power sourcing capabilities of the device. The TAS5727 supports parallel BTL (PBTL) mode with OUT_A/OUT_B (and OUT_C/OUT_D) connected before the LC filter. The merging of the two output channels in this device can be done before the inductor portion of the output filter. This is called *Single-Filter PBTL*, and this mono operation is shown in [Figure 36](#). More information about this can be found in [Single-Filter PBTL Mode](#).

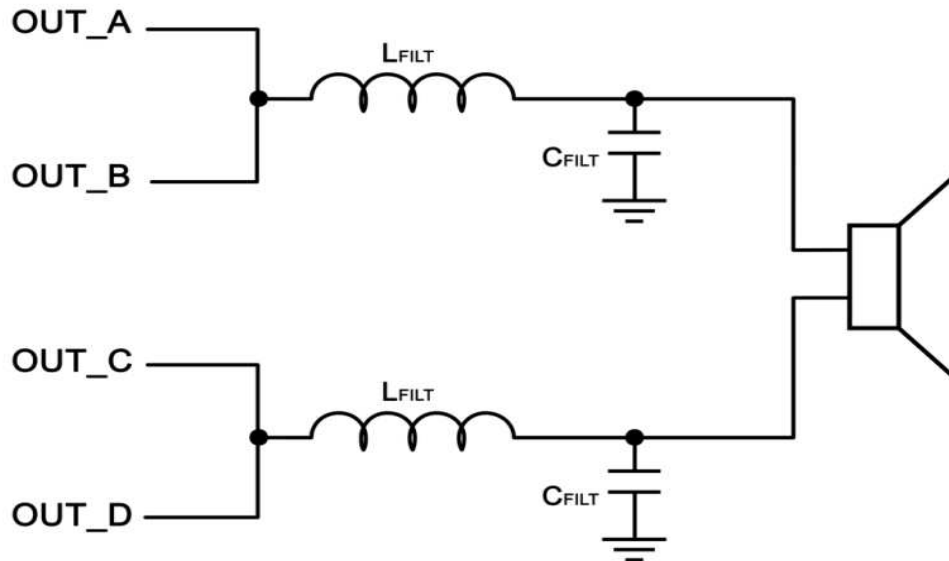

Figure 36. Mono PBTL Mode

10.5 Programming

10.5.1 26-Bit 3.23 Number Format

All mixer gain coefficients are 26-bit coefficients using a 3.23 number format. Numbers formatted as 3.23 numbers means that there are 3 bits to the left of the binary point and 23 bits to the right of the binary point (see [Figure 37](#)).

Programming (continued)

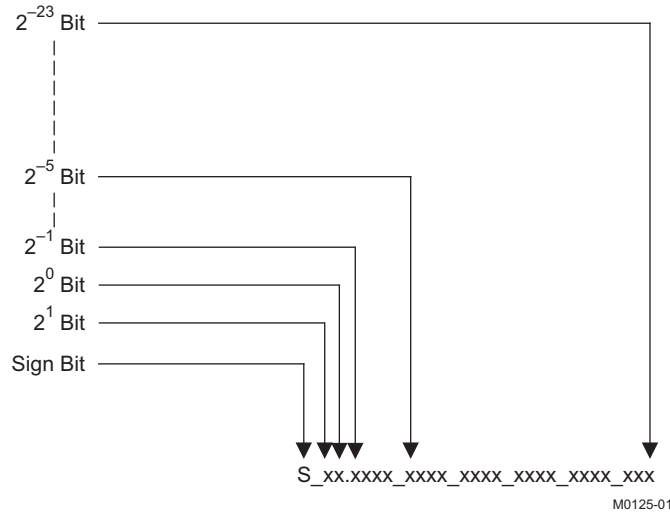

Figure 37. 3.23 Format

The decimal value of a 3.23 format number can be found by following the weighting shown in Figure 37. If the most significant bit is logic 0, the number is a positive number, and the weighting shown yields the correct number. If the most significant bit is a logic 1, then the number is a negative number. In this case every bit must be inverted, a 1 added to the result, and then the weighting shown in Figure 38 applied to obtain the magnitude of the negative number.

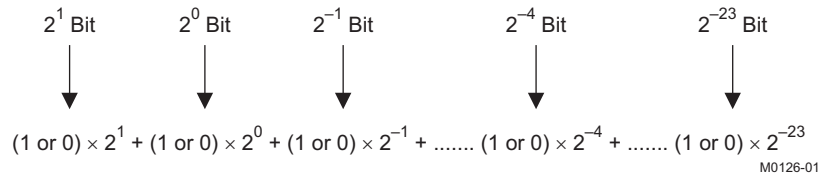

Figure 38. Conversion Weighting Factors—3.23 Format to Floating Point

Gain coefficients, entered through the I²C bus, must be entered as 32-bit binary numbers. Figure 39 shows the format of the 32 bit number (4 byte or 8 digit hexadecimal number).

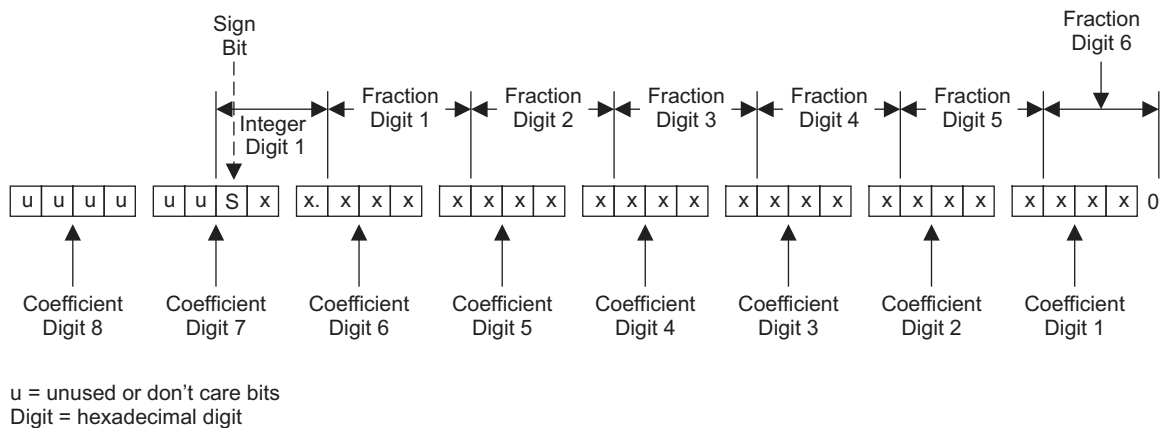

Figure 39. Alignment of 3.23 Coefficient in 32-Bit I²C Word

Table 2. Sample Calculation for 3.23 Format

db	LINEAR	DECIMAL	HEX (3.23 FORMAT)
0	1	8,388,608	80 0000
5	1.77	14,917,288	00E3 9EA8
-5	0.56	4,717,260	0047 FACC
X	$L = 10^{(X/20)}$	$D = 8,388,608 \times L$	$H = \text{dec2hex}(D, 8)$

Table 3. Sample Calculation for 9.17 Format

db	LINEAR	DECIMAL	HEX (9.17 FORMAT)
0	1	131,072	2 0000
5	1.77	231,997	3 8A3D
-5	0.56	73,400	1 1EB8
X	$L = 10^{(X/20)}$	$D = 131,072 \times L$	$H = \text{dec2hex}(D, 8)$

10.6 Register Maps

Table 4. Serial Control Interface Register Summary

SUBADDRESS	REGISTER NAME	NO. OF BYTES	CONTENTS	INITIALIZATION VALUE
			A u indicates unused bits.	
0x00	Clock control register	1	Description shown in subsequent section	0x6C
0x01	Device ID register	1	Description shown in subsequent section	0x43
0x02	Error status register	1	Description shown in subsequent section	0x00
0x03	System control register 1	1	Description shown in subsequent section	0x80
0x04	Serial data interface register	1	Description shown in subsequent section	0x05
0x05	System control register 2	1	Description shown in subsequent section	0x40
0x06	Soft mute register	1	Description shown in subsequent section	0x00
0x07	Master volume	2	Description shown in subsequent section	0xFF (mute)
0x08	Channel 1 vol	2	Description shown in subsequent section	0x30 (0 dB)
0x09	Channel 2 vol	2	Description shown in subsequent section	0x30 (0 dB)
0x0A	Channel 3 vol	2	Description shown in subsequent section	0x30 (0 dB)
0x0B–0x0D		1	Reserved ⁽¹⁾	
0x0E	Volume configuration register	1	Description shown in subsequent section	0x90
0x0F		1	Reserved ⁽¹⁾	
0x10	Modulation limit register	1	Description shown in subsequent section	0x02
0x11	IC delay channel 1	1	Description shown in subsequent section	0xAC
0x12	IC delay channel 2	1	Description shown in subsequent section	0x54
0x13	IC delay channel 3	1	Description shown in subsequent section	0xAC
0x14	IC delay channel 4	1	Description shown in subsequent section	0x54
0x15–0x19		1	Reserved ⁽¹⁾	
0x1A	Start/stop period register	1		0x0F
0x1B	Oscillator trim register	1		0x82
0x1C	BKND_ERR register	1		0x02
0x1D–0x1F		1	Reserved ⁽¹⁾	
0x20	Input MUX register	4	Description shown in subsequent section	0x0001 7772
0x21	Ch 4 source select register	4	Description shown in subsequent section	0x0000 4303
0x22–0x24		4	Reserved ⁽¹⁾	

(1) Reserved registers should not be accessed.

Register Maps (continued)
Table 4. Serial Control Interface Register Summary (continued)

SUBADDRESS	REGISTER NAME	NO. OF BYTES	CONTENTS	INITIALIZATION VALUE
0x25	PWM MUX register	4	Description shown in subsequent section	0x0102 1345
0x26	ch1_bq[0]	20	u[31:26], b0[25:0]	0x0080 0000
			u[31:26], b1[25:0]	0x0000 0000
			u[31:26], b2[25:0]	0x0000 0000
			u[31:26], a1[25:0]	0x0000 0000
0x27	ch1_bq[1]	20	u[31:26], a2[25:0]	0x0000 0000
			u[31:26], b0[25:0]	0x0080 0000
			u[31:26], b1[25:0]	0x0000 0000
			u[31:26], b2[25:0]	0x0000 0000
0x28	ch1_bq[2]	20	u[31:26], a1[25:0]	0x0000 0000
			u[31:26], a2[25:0]	0x0000 0000
			u[31:26], b0[25:0]	0x0080 0000
			u[31:26], b1[25:0]	0x0000 0000
0x29	ch1_bq[3]	20	u[31:26], b2[25:0]	0x0000 0000
			u[31:26], a1[25:0]	0x0000 0000
			u[31:26], a2[25:0]	0x0000 0000
			u[31:26], b0[25:0]	0x0080 0000
0x2A	ch1_bq[4]	20	u[31:26], b1[25:0]	0x0000 0000
			u[31:26], b2[25:0]	0x0000 0000
			u[31:26], a1[25:0]	0x0000 0000
			u[31:26], a2[25:0]	0x0000 0000
0x2B	ch1_bq[5]	20	u[31:26], b0[25:0]	0x0080 0000
			u[31:26], b1[25:0]	0x0000 0000
			u[31:26], b2[25:0]	0x0000 0000
			u[31:26], a1[25:0]	0x0000 0000
0x2C	ch1_bq[6]	20	u[31:26], a2[25:0]	0x0000 0000
			u[31:26], b0[25:0]	0x0080 0000
			u[31:26], b1[25:0]	0x0000 0000
			u[31:26], b2[25:0]	0x0000 0000
0x2D	ch1_bq[7]	20	u[31:26], a1[25:0]	0x0000 0000
			u[31:26], a2[25:0]	0x0000 0000
			u[31:26], b0[25:0]	0x0080 0000
			u[31:26], b1[25:0]	0x0000 0000

Register Maps (continued)
Table 4. Serial Control Interface Register Summary (continued)

SUBADDRESS	REGISTER NAME	NO. OF BYTES	CONTENTS	INITIALIZATION VALUE
0x2E	ch1_bq[8]	20	u[31:26], b0[25:0]	0x0080 0000
			u[31:26], b1[25:0]	0x0000 0000
			u[31:26], b2[25:0]	0x0000 0000
			u[31:26], a1[25:0]	0x0000 0000
			u[31:26], a2[25:0]	0x0000 0000
0x2F	ch1_bq[9]	20	u[31:26], b0[25:0]	0x0080 0000
			u[31:26], b1[25:0]	0x0000 0000
			u[31:26], b2[25:0]	0x0000 0000
			u[31:26], a1[25:0]	0x0000 0000
			u[31:26], a2[25:0]	0x0000 0000
0x30	ch2_bq[0]	20	u[31:26], b0[25:0]	0x0080 0000
			u[31:26], b1[25:0]	0x0000 0000
			u[31:26], b2[25:0]	0x0000 0000
			u[31:26], a1[25:0]	0x0000 0000
			u[31:26], a2[25:0]	0x0000 0000
0x31	ch2_bq[1]	20	u[31:26], b0[25:0]	0x0080 0000
			u[31:26], b1[25:0]	0x0000 0000
			u[31:26], b2[25:0]	0x0000 0000
			u[31:26], a1[25:0]	0x0000 0000
			u[31:26], a2[25:0]	0x0000 0000
0x32	ch2_bq[2]	20	u[31:26], b0[25:0]	0x0080 0000
			u[31:26], b1[25:0]	0x0000 0000
			u[31:26], b2[25:0]	0x0000 0000
			u[31:26], a1[25:0]	0x0000 0000
			u[31:26], a2[25:0]	0x0000 0000
0x33	ch2_bq[3]	20	u[31:26], b0[25:0]	0x0080 0000
			u[31:26], b1[25:0]	0x0000 0000
			u[31:26], b2[25:0]	0x0000 0000
			u[31:26], a1[25:0]	0x0000 0000
			u[31:26], a2[25:0]	0x0000 0000
0x34	ch2_bq[4]	20	u[31:26], b0[25:0]	0x0080 0000
			u[31:26], b1[25:0]	0x0000 0000
			u[31:26], b2[25:0]	0x0000 0000
			u[31:26], a1[25:0]	0x0000 0000
			u[31:26], a2[25:0]	0x0000 0000
0x35	ch2_bq[5]	20	u[31:26], b0[25:0]	0x0080 0000
			u[31:26], b1[25:0]	0x0000 0000
			u[31:26], b2[25:0]	0x0000 0000
			u[31:26], a1[25:0]	0x0000 0000
			u[31:26], a2[25:0]	0x0000 0000
0x36	ch2_bq[6]	20	u[31:26], b0[25:0]	0x0080 0000
			u[31:26], b1[25:0]	0x0000 0000
			u[31:26], b2[25:0]	0x0000 0000
			u[31:26], a1[25:0]	0x0000 0000
			u[31:26], a2[25:0]	0x0000 0000

Register Maps (continued)
Table 4. Serial Control Interface Register Summary (continued)

SUBADDRESS	REGISTER NAME	NO. OF BYTES	CONTENTS	INITIALIZATION VALUE
0x37	ch2_bq[7]	20	u[31:26], b0[25:0]	0x0080 0000
			u[31:26], b1[25:0]	0x0000 0000
			u[31:26], b2[25:0]	0x0000 0000
			u[31:26], a1[25:0]	0x0000 0000
			u[31:26], a2[25:0]	0x0000 0000
0x38	ch2_bq[8]	20	u[31:26], b0[25:0]	0x0080 0000
			u[31:26], b1[25:0]	0x0000 0000
			u[31:26], b2[25:0]	0x0000 0000
			u[31:26], a1[25:0]	0x0000 0000
			u[31:26], a2[25:0]	0x0000 0000
0x39	ch2_bq[9]	20	u[31:26], b0[25:0]	0x0080 0000
			u[31:26], b1[25:0]	0x0000 0000
			u[31:26], b2[25:0]	0x0000 0000
			u[31:26], a1[25:0]	0x0000 0000
			u[31:26], a2[25:0]	0x0000 0000
0x3A		4	Reserved ⁽¹⁾	
0x3B	DRC1 softening filter alpha	8	u[31:26], ae[25:0]	0x0008 0000
	DRC1 softening filter omega		u[31:26], oe[25:0]	0x0078 0000
0x3C	DRC1 attack rate	8		0x0000 0100
	DRC1 release rate			0xFFFF FF00

Register Maps (continued)
Table 4. Serial Control Interface Register Summary (continued)

SUBADDRESS	REGISTER NAME	NO. OF BYTES	CONTENTS	INITIALIZATION VALUE
0x3D		8	Reserved ⁽¹⁾	
0x3E	DRC2 softening filter alpha	8	u[31:26], ae[25:0]	0x0008 0000
	DRC2 softening filter omega		u[31:26], oe[25:0]	0xFFFF 0000
0x3F	DRC2 attack rate	8	u[31:26], at[25:0]	0x0008 0000
	DRC2 release rate		u[31:26], rt[25:0]	0xFFFF 0000
0x40	DRC1 attack threshold	4	T1[31:0] (9.23 format)	0x0800 0000
0x41–0x42		4	Reserved ⁽¹⁾	
0x43	DRC2 attack threshold	4	T2[31:0] (9.23 format)	0x0074 0000
0x44–0x45		4	Reserved ⁽¹⁾	
0x46	DRC control	4	Description shown in subsequent section	0x0000 0000
0x47–0x4E		4	Reserved ⁽¹⁾	
0x4F	PWM switching rate control	4	u[31:4], src[3:0]	0x0000 0006
0x50	Bank switch control	4	Description shown in subsequent section	0x0F70 8000
0x51	Ch 1 output mixer	8	Ch 1 output mix1[1]	0x0080 0000
			Ch 1 output mix1[0]	0x0000 0000
0x52	Ch 2 output mixer	8	Ch 2 output mix2[1]	0x0080 0000
			Ch 2 output mix2[0]	0x0000 0000
0x53		16	Reserved ⁽¹⁾	
0x54		16	Reserved ⁽¹⁾	
0x56	Output post-scale	4	u[31:26], post[25:0]	0x0080 0000
0x57	Output pre-scale	4	u[31:26], pre[25:0] (9.17 format)	0x0002 0000
0x58	ch1_bq[10]	20	u[31:26], b0[25:0]	0x0080 0000
			u[31:26], b1[25:0]	0x0000 0000
			u[31:26], b2[25:0]	0x0000 0000
			u[31:26], a1[25:0]	0x0000 0000
			u[31:26], a2[25:0]	0x0000 0000
0x59	ch1_bq[11]	20	u[31:26], b0[25:0]	0x0080 0000
			u[31:26], b1[25:0]	0x0000 0000
			u[31:26], b2[25:0]	0x0000 0000
			u[31:26], a1[25:0]	0x0000 0000
			u[31:26], a2[25:0]	0x0000 0000
0x5A	ch4_bq[0]	20	u[31:26], b0[25:0]	0x0080 0000
			u[31:26], b1[25:0]	0x0000 0000
			u[31:26], b2[25:0]	0x0000 0000
			u[31:26], a1[25:0]	0x0000 0000
			u[31:26], a2[25:0]	0x0000 0000
0x5B	ch4_bq[1]	20	u[31:26], b0[25:0]	0x0080 0000
			u[31:26], b1[25:0]	0x0000 0000
			u[31:26], b2[25:0]	0x0000 0000
			u[31:26], a1[25:0]	0x0000 0000
			u[31:26], a2[25:0]	0x0000 0000

Register Maps (continued)
Table 4. Serial Control Interface Register Summary (continued)

SUBADDRESS	REGISTER NAME	NO. OF BYTES	CONTENTS	INITIALIZATION VALUE
0x5C	ch2_bq[10]	20	u[31:26], b0[25:0]	0x0080 0000
			u[31:26], b1[25:0]	0x0000 0000
			u[31:26], b2[25:0]	0x0000 0000
			u[31:26], a1[25:0]	0x0000 0000
			u[31:26], a2[25:0]	0x0000 0000
0x5D	ch2_bq[11]	20	u[31:26], b0[25:0]	0x0080 0000
			u[31:26], b1[25:0]	0x0000 0000
			u[31:26], b2[25:0]	0x0000 0000
			u[31:26], a1[25:0]	0x0000 0000
			u[31:26], a2[25:0]	0x0000 0000
0x5E	ch3_bq[0]	20	u[31:26], b0[25:0]	0x0080 0000
			u[31:26], b1[25:0]	0x0000 0000
			u[31:26], b2[25:0]	0x0000 0000
			u[31:26], a1[25:0]	0x0000 0000
			u[31:26], a2[25:0]	0x0000 0000
0x5F	ch3_bq[1]	20	u[31:26], b0[25:0]	0x0080 0000
			u[31:26], b1[25:0]	0x0000 0000
			u[31:26], b2[25:0]	0x0000 0000
			u[31:26], a1[25:0]	0x0000 0000
			u[31:26], a2[25:0]	0x0000 0000
0x60–0x61		4	Reserved ⁽¹⁾	
0x62	IDF post scale	4		0x0000 0080
0x63–0x6A			Reserved ⁽¹⁾	
0x6B	Left channel PWM level meter	4	Data[31:0]	0x0000 0000
0x6C	Right channel PWM level meter	4	Data[31:0]	0x0000 0000
0x6D–0x6F			Reserved ⁽¹⁾	
0x70	ch1 inline mixer	4	u[31:26], in_mix1[25:0]	0x0080 0000
0x71	inline_DRC_en_mixer_ch1	4	u[31:26], in_mixdrc_1[25:0]	0x0000 0000
0x72	ch1 right_channel mixer	4	u[31:26], right_mix1[25:0]	0x0000 0000
0x73	ch1 left_channel_mixer	4	u[31:26], left_mix_1[25:0]	0x0080 0000
0x74	ch2 inline mixer	4	u[31:26], in_mix2[25:0]	0x0080 0000
0x75	inline_DRC_en_mixer_ch2	4	u[31:26], in_mixdrc_2[25:0]	0x0000 0000
0x76	ch2 left_chanel mixer	4	u[31:26], left_mix1[25:0]	0x0000 0000
0x77	ch2 right_channel_mixer	4	u[31:26], right_mix_1[25:0]	0x0080 0000
0x78–0x7F			Reserved ⁽¹⁾	
0xF8	Update dev address key	4	Dev Id Update Key[31:0] (Key = 0xF9A5A5A5)	0x0000 0000
0xF9	Update dev address reg	4	u[31:8], New Dev Id[7:0] (New Dev Id = 0x38 for TAS5727)	0x0000 0036
0xFA–0xFF		4	Reserved ⁽¹⁾	

All DAP coefficients are 3.23 format unless specified otherwise.

Registers 0x3B through 0x46 should be altered only during the initialization phase.

10.6.1 Clock Control Register (0x00)

The clocks and data rates are automatically determined by the TAS5727. The clock control register contains the autodetected clock status. Bits D7–D5 reflect the sample rate. Bits D4–D2 reflect the MCLK frequency.

Table 5. Clock Control Register (0x00)

D7	D6	D5	D4	D3	D2	D1	D0	FUNCTION
0	0	0	–	–	–	–	–	$f_S = 32\text{-kHz}$ sample rate
0	0	1	–	–	–	–	–	Reserved
0	1	0	–	–	–	–	–	Reserved
0	1	1	–	–	–	–	–	$f_S = 44.1/48\text{-kHz}$ sample rate⁽¹⁾
1	0	0	–	–	–	–	–	$f_S = 16\text{-kHz}$ sample rate
1	0	1	–	–	–	–	–	$f_S = 22.05/24\text{-kHz}$ sample rate
1	1	0	–	–	–	–	–	$f_S = 8\text{-kHz}$ sample rate
1	1	1	–	–	–	–	–	$f_S = 11.025/12\text{-kHz}$ sample rate
–	–	–	0	0	0	–	–	MCLK frequency = $64 \times f_S$ ⁽²⁾
–	–	–	0	0	1	–	–	MCLK frequency = $128 \times f_S$ ⁽²⁾
–	–	–	0	1	0	–	–	MCLK frequency = $192 \times f_S$ ⁽³⁾
–	–	–	0	1	1	–	–	MCLK frequency = $256 \times f_S$⁽¹⁾⁽⁴⁾
–	–	–	1	0	0	–	–	MCLK frequency = $384 \times f_S$
–	–	–	1	0	1	–	–	MCLK frequency = $512 \times f_S$
–	–	–	1	1	0	–	–	Reserved
–	–	–	1	1	1	–	–	Reserved
–	–	–	–	–	–	0	–	Reserved⁽¹⁾
–	–	–	–	–	–	–	0	Reserved⁽¹⁾

(1) Default values are in **bold**.

(2) Only available for 44.1-kHz and 48-kHz rates

(3) Rate only available for 32/44.1/48-KHz sample rates

(4) Not available at 8 kHz

10.6.2 Device Id Register (0x01)

The device ID register contains the ID code for the firmware revision.

Table 6. General Status Register (0x01)

D7	D6	D5	D4	D3	D2	D1	D0	FUNCTION
0	0	0	0	0	0	0	0	Identification code⁽¹⁾

(1) Default values are in **bold**.

10.6.3 Error Status Register (0x02)

The error bits are sticky and are not cleared by the hardware. This means that the software must clear the register (write zeroes) and then read them to determine if they are persistent errors.

Error definitions:

- MCLK error: MCLK frequency is changing. The number of MCLKs per LRCLK is changing.
- SCLK error: The number of SCLKs per LRCLK is changing.
- LRCLK error: LRCLK frequency is changing.
- Frame slip: LRCLK phase is drifting with respect to internal frame sync.

Table 7. Error Status Register (0x02)

D7	D6	D5	D4	D3	D2	D1	D0	FUNCTION
1	-	-	-	-	-	-	-	MCLK error
-	1	-	-	-	-	-	-	PLL autolock error
-	-	1	-	-	-	-	-	SCLK error
-	-	-	1	-	-	-	-	LRCLK error
-	-	-	-	1	-	-	-	Frame slip
-	-	-	-	-	1	-	-	Clip indicator
-	-	-	-	-	-	1	-	Overcurrent, overtemperature, overvoltage, or undervoltage error
0	0	0	0	0	0	0	0	Reserved
0	0	0	0	0	0	0	0	No errors ⁽¹⁾

(1) Default values are in **bold**.

10.6.4 System Control Register 1 (0x03)

System control register 1 has several functions:

Bit D7: If 0, the DC-blocking filter for each channel is disabled.

If 1, the DC-blocking filter (-3 dB cutoff <1 Hz) for each channel is enabled.

Bit D5: If 0, use soft unmute on recovery from a clock error. This is a slow recovery. Unmute takes the same time as the volume ramp defined in register 0x0E.

If 1, use hard unmute on recovery from clock error. This is a fast recovery, a single-step volume ramp.

Bits D1–D0: Select de-emphasis

Table 8. System Control Register 1 (0x03)

D7	D6	D5	D4	D3	D2	D1	D0	FUNCTION
0	-	-	-	-	-	-	-	PWM high-pass (dc blocking) disabled
1	-	-	-	-	-	-	-	PWM high-pass (dc blocking) enabled ⁽¹⁾
-	0	-	-	-	-	-	-	Reserved ⁽¹⁾
-	-	0	-	-	-	-	-	Soft unmute on recovery from clock error ⁽¹⁾
-	-	1	-	-	-	-	-	Hard unmute on recovery from clock error
-	-	-	1	-	-	-	-	Reserved ⁽¹⁾
-	-	-	-	0	-	-	-	Reserved ⁽¹⁾
-	-	-	-	-	0	-	-	Reserved ⁽¹⁾
-	-	-	-	-	-	0	0	No de-emphasis ⁽¹⁾
-	-	-	-	-	-	0	1	De-emphasis for $f_S = 32$ kHz
-	-	-	-	-	-	1	0	De-emphasis for $f_S = 44.1$ kHz
-	-	-	-	-	-	1	1	De-emphasis for $f_S = 48$ kHz

(1) Default values are in **bold**.

10.6.5 Serial Data Interface Register (0x04)

As shown in [Table 9](#), the TAS5727 supports nine serial data modes. The default is 24-bit, I²S mode.

Table 9. Serial Data Interface Control Register (0x04) Format

RECEIVE SERIAL DATA INTERFACE FORMAT	WORD LENGTH	D7–D4	D3	D2	D1	D0
Right-justified	16	0000	0	0	0	0
Right-justified	20	0000	0	0	0	1
Right-justified	24	0000	0	0	1	0
I ² S	16	000	0	0	1	1
I ² S	20	0000	0	1	0	0
I²S⁽¹⁾	24	0000	0	1	0	1
Left-justified	16	0000	0	1	1	0
Left-justified	20	0000	0	1	1	1
Left-justified	24	0000	1	0	0	0
Reserved		0000	1	0	0	1
Reserved		0000	1	0	1	0
Reserved		0000	1	0	1	1
Reserved		0000	1	1	0	0
Reserved		0000	1	1	0	1
Reserved		0000	1	1	1	0
Reserved		0000	1	1	1	1

(1) Default values are in **bold**.

10.6.6 System Control Register 2 (0x05)

When bit D6 is set low, the system exits all-channel shutdown and starts playing audio; otherwise, the outputs are shut down (hard mute).

Table 10. System Control Register 2 (0x05)

D7	D6	D5	D4	D3	D2	D1	D0	FUNCTION
0	–	–	–	–	–	–	–	Mid-Z ramp disabled ⁽¹⁾
1	–	–	–	–	–	–	–	Mid-Z ramp enabled
–	0	–	–	–	–	–	–	Exit all-channel shutdown (normal operation)
–	1	–	–	–	–	–	–	Enter all-channel shutdown (hard mute) ⁽¹⁾
–	–	0	0	–	–	–	–	Reserved ⁽¹⁾
–	–	–	–	0	–	–	–	Ternary modulation disabled ⁽¹⁾
–	–	–	–	1	–	–	–	Ternary modulation enabled
–	–	–	–	–	0	–	–	Reserved ⁽¹⁾
–	–	–	–	–	–	0	–	A_SEL_FAULT configured as input
–	–	–	–	–	–	1	–	A_SEL_FAULT configured configured as output to function as A_SEL_FAULT pin.
–	–	–	–	–	–	–	0	Reserved ⁽¹⁾

(1) Default values are in **bold**.

Ternary modulation is disabled by default. To enable ternary modulation, the following writes are required before bringing the system out of shutdown:

1. Set bit D3 of register 0x05 to 1.
2. Write the following ICD settings:
 - (a) 0x11= 80
 - (b) 0x12= 7C
 - (c) 0x13= 80
 - (d) 0x24 =7C
3. Set the input mux register as follows:
 - (a) 0x20 = 00 89 77 72

10.6.7 Soft Mute Register (0x06)

Writing a 1 to any of the following bits sets the output of the respective channel to 50% duty cycle (soft mute).

Table 11. Soft Mute Register (0x06)

D7	D6	D5	D4	D3	D2	D1	D0	FUNCTION
0	0	0	0	0	–	–	–	Reserved ⁽¹⁾
–	–	–	–	–	1	–	–	Soft mute channel 3
–	–	–	–	–	0	–	–	Soft unmute channel 3 ⁽¹⁾
–	–	–	–	–	–	1	–	Soft mute channel 2
–	–	–	–	–	–	0	–	Soft unmute channel 2 ⁽¹⁾
–	–	–	–	–	–	–	1	Soft mute channel 1
–	–	–	–	–	–	–	0	Soft unmute channel 1 ⁽¹⁾

(1) Default values are in **bold**.

10.6.8 Volume Registers (0x07, 0x08, 0x09)

Step size is 0.125 dB and volume registers are 2 bytes.

- Master volume – 0x07 (default is mute)
- Channel-1 volume – 0x08 (default is 0 dB)
- Channel-2 volume – 0x09 (default is 0 dB)

Table 12. Master Volume Table

VALUE	LEVEL	VALUE	LEVEL	VALUE	LEVEL	VALUE	LEVEL	VALUE	LEVEL	VALUE	LEVEL
0x0000	24.000	0x0027	19.250	0x004E	14.250	0x0075	9.375	0x009C	4.500	0x00C3	-0.375
0x0001	23.875	0x0028	19.000	0x004F	14.125	0x0076	9.250	0x009D	4.375	0x00C4	-0.500
0x0002	23.750	0x0029	18.875	0x0050	14.000	0x0077	9.125	0x009E	4.250	0x00C5	-0.625
0x0003	23.625	0x002A	18.750	0x0051	13.875	0x0078	9.000	0x009F	4.125	0x00C6	-0.750
0x0004	23.500	0x002B	18.625	0x0052	13.750	0x0079	8.875	0x00A0	4.000	0x00C7	-0.875
0x0005	23.375	0x002C	18.500	0x0053	13.625	0x007A	8.750	0x00A1	3.875	0x00C8	-1.000
0x0006	23.250	0x002D	18.375	0x0054	13.500	0x007B	8.625	0x00A2	3.750	0x00C9	-1.125
0x0007	23.125	0x002E	18.250	0x0055	13.375	0x007C	8.500	0x00A3	3.625	0x00CA	-1.250
0x0008	23.000	0x002F	18.125	0x0056	13.250	0x007D	8.375	0x00A4	3.500	0x00CB	-1.375
0x0009	22.875	0x0030	18.000	0x0057	13.125	0x007E	8.250	0x00A5	3.375	0x00CC	-1.500
0x000A	22.750	0x0031	17.875	0x0058	13.000	0x007F	8.125	0x00A6	3.250	0x00CD	-1.625
0x000B	22.625	0x0032	17.750	0x0059	12.875	0x0080	8.000	0x00A7	3.125	0x00CE	-1.750
0x000C	22.500	0x0033	17.625	0x005A	12.750	0x0081	7.875	0x00A8	3.000	0x00CF	-1.875
0x000D	22.375	0x0034	17.500	0x005B	12.625	0x0082	7.750	0x00A9	2.875	0x00D0	-2.000
0x000E	22.250	0x0035	17.375	0x005C	12.500	0x0083	7.625	0x00AA	2.750	0x00D1	-2.125
0x000F	22.125	0x0036	17.250	0x005D	12.375	0x0084	7.500	0x00AB	2.625	0x00D2	-2.250
0x0010	22.000	0x0037	17.125	0x005E	12.250	0x0085	7.375	0x00AC	2.500	0x00D3	-2.375
0x0011	21.875	0x0038	17.000	0x005F	12.125	0x0086	7.250	0x00AD	2.375	0x00D4	-2.500
0x0012	21.750	0x0039	16.875	0x0060	12.000	0x0087	7.125	0x00AE	2.250	0x00D5	-2.625
0x0013	21.625	0x003A	16.750	0x0061	11.875	0x0088	7.000	0x00AF	2.125	0x00D6	-2.750
0x0014	21.500	0x003B	16.625	0x0062	11.750	0x0089	6.875	0x00B0	2.000	0x00D7	-2.875
0x0015	21.375	0x003C	16.500	0x0063	11.625	0x008A	6.750	0x00B1	1.875	0x00D8	-3.000
0x0016	21.250	0x003D	16.375	0x0064	11.500	0x008B	6.625	0x00B2	1.750	0x00D9	-3.125
0x0017	21.125	0x003E	16.250	0x0065	11.375	0x008C	6.500	0x00B3	1.625	0x00DA	-3.250
0x0018	21.000	0x003F	16.125	0x0066	11.250	0x008D	6.375	0x00B4	1.500	0x00DB	-3.375
0x0019	20.875	0x0040	16.000	0x0067	11.125	0x008E	6.250	0x00B5	1.375	0x00DC	-3.500
0x001A	20.750	0x0041	15.875	0x0068	11.000	0x008F	6.125	0x00B6	1.250	0x00DD	-3.625
0x001B	20.625	0x0042	15.750	0x0069	10.875	0x0090	6.000	0x00B7	1.125	0x00DE	-3.750
0x001C	20.500	0x0043	15.625	0x006A	10.750	0x0091	5.875	0x00B8	1.000	0x00DF	-3.875
0x001D	20.375	0x0044	15.500	0x006B	10.625	0x0092	5.750	0x00B9	0.875	0x00E0	-4.000
0x001E	20.250	0x0045	15.375	0x006C	10.500	0x0093	5.625	0x00BA	0.750	0x00E1	-4.125
0x001F	20.125	0x0046	15.250	0x006D	10.375	0x0094	5.500	0x00BB	0.625	0x00E2	-4.250
0x0020	20.000	0x0047	15.125	0x006E	10.250	0x0095	5.375	0x00BC	0.500	0x00E3	-4.375
0x0021	19.875	0x0048	15.000	0x006F	10.125	0x0096	5.250	0x00BD	0.375	0x00E4	-4.500
0x0022	19.750	0x0049	14.875	0x0070	10.000	0x0097	5.125	0x00BE	0.250	0x00E5	-4.625
0x0023	19.625	0x004A	14.750	0x0071	9.875	0x0098	5.000	0x00BF	0.125	0x00E6	-4.750
0x0024	19.500	0x004B	14.625	0x0072	9.750	0x0099	4.875	0x00C0	0.000	0x00E7	-4.875
0x0025	19.375	0x004C	14.500	0x0073	9.625	0x009A	4.750	0x00C1	-0.125	0x00E8	-5.000
0x0026	19.125	0x004D	14.375	0x0074	9.500	0x009B	4.625	0x00C2	-0.250	0x00E9	-5.125

Table 12. Master Volume Table (continued)

VALUE	LEVEL	VALUE	LEVEL	VALUE	LEVEL	VALUE	LEVEL	VALUE	LEVEL	VALUE	LEVEL
0x00EA	-5.250	0x0119	-11.125	0x0148	-17.000	0x0177	-22.875	0x01A6	-28.750	0x01D5	-34.625
0x00EB	-5.375	0x011A	-11.250	0x0149	-17.125	0x0178	-23.000	0x01A7	-28.875	0x01D6	-34.750
0x00EC	-5.500	0x011B	-11.375	0x014A	-17.250	0x0179	-23.125	0x01A8	-29.000	0x01D7	-34.875
0x00ED	-5.625	0x011C	-11.500	0x014B	-17.375	0x017A	-23.250	0x01A9	-29.125	0x01D8	-35.000
0x00EE	-5.750	0x011D	-11.625	0x014C	-17.500	0x017B	-23.375	0x01AA	-29.250	0x01D9	-35.125
0x00EF	-5.875	0x011E	-11.750	0x014D	-17.625	0x017C	-23.500	0x01AB	-29.375	0x01DA	-35.250
0x00F0	-6.000	0x011F	-11.875	0x014E	-17.750	0x017D	-23.625	0x01AC	-29.500	0x01DB	-35.375
0x00F1	-6.125	0x0120	-12.000	0x014F	-17.875	0x017E	-23.750	0x01AD	-29.625	0x01DC	-35.500
0x00F2	-6.250	0x0121	-12.125	0x0150	-18.000	0x017F	-23.875	0x01AE	-29.750	0x01DD	-35.625
0x00F3	-6.375	0x0122	-12.250	0x0151	-18.125	0x0180	-24.000	0x01AF	-29.875	0x01DE	-35.750
0x00F4	-6.500	0x0123	-12.375	0x0152	-18.250	0x0181	-24.125	0x01B0	-30.000	0x01DF	-35.875
0x00F5	-6.625	0x0124	-12.500	0x0153	-18.375	0x0182	-24.250	0x01B1	-30.125	0x01E0	-36.000
0x00F6	-6.750	0x0125	-12.625	0x0154	-18.500	0x0183	-24.375	0x01B2	-30.250	0x01E1	-36.125
0x00F7	-6.875	0x0126	-12.750	0x0155	-18.625	0x0184	-24.500	0x01B3	-30.375	0x01E2	-36.250
0x00F8	-7.000	0x0127	-12.875	0x0156	-18.750	0x0185	-24.625	0x01B4	-30.500	0x01E3	-36.375
0x00F9	-7.125	0x0128	-13.000	0x0157	-18.875	0x0186	-24.750	0x01B5	-30.625	0x01E4	-36.500
0x00FA	-7.250	0x0129	-13.125	0x0158	-19.000	0x0187	-24.875	0x01B6	-30.750	0x01E5	-36.625
0x00FB	-7.375	0x012A	-13.250	0x0159	-19.125	0x0188	-25.000	0x01B7	-30.875	0x01E6	-36.750
0x00FC	-7.500	0x012B	-13.375	0x015A	-19.250	0x0189	-25.125	0x01B8	-31.000	0x01E7	-36.875
0x00FD	-7.625	0x012C	-13.500	0x015B	-19.375	0x018A	-25.250	0x01B9	-31.125	0x01E8	-37.000
0x00FE	-7.750	0x012D	-13.625	0x015C	-19.500	0x018B	-25.375	0x01BA	-31.250	0x01E9	-37.125
0x00FF	-7.875	0x012E	-13.750	0x015D	-19.625	0x018C	-25.500	0x01BB	-31.375	0x01EA	-37.250
0x0100	-8.000	0x012F	-13.875	0x015E	-19.750	0x018D	-25.625	0x01BC	-31.500	0x01EB	-37.375
0x0101	-8.125	0x0130	-14.000	0x015F	-20.875	0x018E	-25.750	0x01BD	-31.625	0x01EC	-37.500
0x0102	-8.250	0x0131	-14.125	0x0160	-20.000	0x018F	-25.875	0x01BE	-31.750	0x01ED	-37.625
0x0103	-8.375	0x0132	-14.250	0x0161	-20.125	0x0190	-26.000	0x01BF	-31.875	0x01EE	-37.750
0x0104	-8.500	0x0133	-14.375	0x0162	-20.250	0x0191	-26.125	0x01C0	-32.000	0x01EF	-37.875
0x0105	-8.625	0x0134	-14.500	0x0163	-20.375	0x0192	-26.250	0x01C1	-32.125	0x01F0	-38.000
0x0106	-8.750	0x0135	-14.625	0x0164	-20.500	0x0193	-26.375	0x01C2	-32.250	0x01F1	-38.125
0x0107	-8.875	0x0136	-14.750	0x0165	-20.625	0x0194	-26.500	0x01C3	-32.375	0x01F2	-38.250
0x0108	-9.000	0x0137	-14.875	0x0166	-20.750	0x0195	-26.625	0x01C4	-32.500	0x01F3	-38.375
0x0109	-9.125	0x0138	-15.000	0x0167	-20.875	0x0196	-26.750	0x01C5	-32.625	0x01F4	-38.500
0x010A	-9.250	0x0139	-15.125	0x0168	-21.000	0x0197	-26.875	0x01C6	-32.750	0x01F5	-38.625
0x010B	-9.375	0x013A	-15.250	0x0169	-21.125	0x0198	-27.000	0x01C7	-32.875	0x01F6	-38.750
0x010C	-9.500	0x013B	-15.375	0x016A	-21.250	0x0199	-27.125	0x01C8	-33.000	0x01F7	-38.875
0x010D	-9.625	0x013C	-15.500	0x016B	-21.375	0x019A	-27.250	0x01C9	-33.125	0x01F8	-39.000
0x010E	-9.750	0x013D	-15.625	0x016C	-21.500	0x019B	-27.375	0x01CA	-33.250	0x01F9	-39.125
0x010F	-9.875	0x013E	-15.750	0x016D	-21.625	0x019C	-27.500	0x01CB	-33.375	0x01FA	-39.250
0x0110	-10.000	0x013F	-15.875	0x016E	-21.750	0x019D	-27.625	0x01CC	-33.500	0x01FB	-39.375
0x0111	-10.125	0x0140	-16.000	0x016F	-21.875	0x019E	-27.750	0x01CD	-33.625	0x01FC	-39.500
0x0112	-10.250	0x0141	-16.125	0x0170	-22.000	0x019F	-27.875	0x01CE	-33.750	0x01FD	-39.625
0x0113	-10.375	0x0142	-16.250	0x0171	-22.125	0x01A0	-28.000	0x01CF	-33.875	0x01FE	-39.750
0x0114	-10.500	0x0143	-16.375	0x0172	-22.250	0x01A1	-28.125	0x01D0	-34.000	0x01FF	-39.875
0x0115	-10.625	0x0144	-16.500	0x0173	-22.375	0x01A2	-28.250	0x01D1	-34.125	0x0200	-40.000
0x0116	-10.750	0x0145	-16.625	0x0174	-22.500	0x01A3	-28.375	0x01D2	-34.250	0x0201	-40.125
0x0117	-10.875	0x0146	-16.750	0x0175	-22.625	0x01A4	-28.500	0x01D3	-34.375	0x0202	-40.250
0x0118	-11.000	0x0147	-16.875	0x0176	-22.750	0x01A5	-28.625	0x01D4	-34.500	0x0203	-40.375

Table 12. Master Volume Table (continued)

VALUE	LEVEL	VALUE	LEVEL	VALUE	LEVEL	VALUE	LEVEL	VALUE	LEVEL	VALUE	LEVEL
0x0204	-40.500	0x0233	-46.375	0x0262	-52.250	0x0291	-58.250	0x02C0	-64.000	0x02EF	-69.875
0x0205	-40.625	0x0234	-46.500	0x0263	-52.375	0x0292	-58.125	0x02C1	-64.125	0x02F0	-70.000
0x0206	-40.750	0x0235	-46.625	0x0264	-52.500	0x0293	-58.375	0x02C2	-64.250	0x02F1	-70.125
0x0207	-40.875	0x0236	-46.750	0x0265	-52.625	0x0294	-58.500	0x02C3	-64.375	0x02F2	-70.250
0x0208	-41.000	0x0237	-46.875	0x0266	-52.750	0x0295	-58.625	0x02C4	-64.500	0x02F3	-70.375
0x0209	-41.125	0x0238	-47.000	0x0267	-52.875	0x0296	-58.750	0x02C5	-64.625	0x02F4	-70.500
0x020A	-41.250	0x0239	-47.125	0x0268	-53.000	0x0297	-58.875	0x02C6	-64.750	0x02F5	-70.625
0x020B	-41.375	0x023A	-47.250	0x0269	-53.125	0x0298	-59.000	0x02C7	-64.875	0x02F6	-70.750
0x020C	-41.500	0x023B	-47.375	0x026A	-53.250	0x0299	-59.125	0x02C8	-65.000	0x02F7	-70.875
0x020D	-41.625	0x023C	-47.500	0x026B	-53.375	0x029A	-59.250	0x02C9	-65.125	0x02F8	-71.000
0x020E	-41.750	0x023D	-47.625	0x026C	-53.500	0x029B	-59.375	0x02CA	-65.250	0x02F9	-71.125
0x020F	-41.875	0x023E	-47.750	0x026D	-53.625	0x029C	-59.500	0x02CB	-65.375	0x02FA	-71.250
0x0210	-42.000	0x023F	-47.875	0x026E	-53.750	0x029D	-59.625	0x02CC	-65.500	0x02FB	-71.375
0x0211	-42.125	0x0240	-48.000	0x026F	-53.875	0x029E	-59.750	0x02CD	-65.625	0x02FC	-71.500
0x0212	-42.250	0x0241	-48.125	0x0270	-54.000	0x029F	-59.875	0x02CE	-65.750	0x02FD	-71.625
0x0213	-42.375	0x0242	-48.250	0x0271	-54.125	0x02A0	-60.000	0x02CF	-65.875	0x02FE	-71.750
0x0214	-42.500	0x0243	-48.375	0x0272	-54.250	0x02A1	-60.125	0x02D0	-66.000	0x02FF	-71.875
0x0215	-42.625	0x0244	-48.500	0x0273	-54.375	0x02A2	-60.250	0x02D1	-66.125	0x0300	-72.000
0x0216	-42.750	0x0245	-48.625	0x0274	-54.500	0x02A3	-60.375	0x02D2	-66.250	0x0301	-72.125
0x0217	-42.875	0x0246	-48.750	0x0275	-54.625	0x02A4	-60.500	0x02D3	-66.375	0x0302	-72.250
0x0218	-43.000	0x0247	-48.875	0x0276	-54.750	0x02A5	-60.625	0x02D4	-66.500	0x0303	-72.375
0x0219	-43.125	0x0248	-49.000	0x0277	-54.875	0x02A6	-60.750	0x02D5	-66.625	0x0304	-72.500
0x021A	-43.250	0x0249	-49.125	0x0278	-55.000	0x02A7	-60.875	0x02D6	-66.750	0x0305	-72.625
0x021B	-43.375	0x024A	-49.250	0x0279	-55.125	0x02A8	-61.000	0x02D7	-66.875	0x0306	-72.750
0x021C	-43.500	0x024B	-49.375	0x027A	-55.250	0x02A9	-61.125	0x02D8	-67.000	0x0307	-72.875
0x021D	-43.625	0x024C	-49.500	0x027B	-55.375	0x02AA	-61.250	0x02D9	-67.125	0x0308	-73.000
0x021E	-43.750	0x024D	-49.625	0x027C	-55.500	0x02AB	-61.375	0x02DA	-67.250	0x0309	-73.125
0x021F	-43.875	0x024E	-49.750	0x027D	-55.625	0x02AC	-61.500	0x02DB	-67.375	0x030A	-73.250
0x0220	-44.000	0x024F	-49.875	0x027E	-55.750	0x02AD	-61.625	0x02DC	-67.500	0x030B	-73.375
0x0221	-44.125	0x0250	-50.000	0x027F	-55.875	0x02AE	-61.750	0x02DD	-67.625	0x030C	-73.500
0x0222	-44.250	0x0251	-50.125	0x0280	-56.000	0x02AF	-61.875	0x02DE	-67.750	0x030D	-73.625
0x0223	-44.375	0x0252	-50.250	0x0281	-56.250	0x02B0	-62.000	0x02DF	-67.875	0x030E	-73.750
0x0224	-44.500	0x0253	-50.375	0x0282	-56.125	0x02B1	-62.125	0x02E0	-68.000	0x030F	-73.875
0x0225	-44.625	0x0254	-50.500	0x0283	-56.375	0x02B2	-62.250	0x02E1	-68.125	0x0310	-74.000
0x0226	-44.750	0x0255	-50.625	0x0284	-56.500	0x02B3	-62.375	0x02E2	-68.250	0x0311	-74.250
0x0227	-44.875	0x0256	-50.750	0x0285	-56.625	0x02B4	-62.500	0x02E3	-68.375	0x0312	-74.125
0x0228	-45.000	0x0257	-50.875	0x0286	-56.750	0x02B5	-62.625	0x02E4	-68.500	0x0313	-74.375
0x0229	-45.125	0x0258	-51.000	0x0287	-56.875	0x02B6	-62.750	0x02E5	-68.625	0x0314	-74.500
0x022A	-45.250	0x0259	-51.125	0x0288	-57.000	0x02B7	-62.875	0x02E6	-68.750	0x0315	-74.625
0x022B	-45.375	0x025A	-51.250	0x0289	-57.125	0x02B8	-63.000	0x02E7	-68.875	0x0316	-74.750
0x022C	-45.500	0x025B	-51.375	0x028A	-57.250	0x02B9	-63.125	0x02E8	-69.000	0x0317	-74.875
0x022D	-45.625	0x025C	-51.500	0x028B	-57.375	0x02BA	-63.250	0x02E9	-69.125	0x0318	-75.000
0x022E	-45.750	0x025D	-51.625	0x028C	-57.500	0x02BB	-63.375	0x02EA	-69.250	0x0319	-75.125
0x022F	-45.875	0x025E	-51.750	0x028D	-57.625	0x02BC	-63.500	0x02EB	-69.375	0x031A	-75.250
0x0230	-46.000	0x025F	-51.875	0x028E	-57.750	0x02BD	-63.625	0x02EC	-69.500	0x031B	-75.375
0x0231	-46.125	0x0260	-52.000	0x028F	-57.875	0x02BE	-63.750	0x02ED	-69.625	0x031C	-75.500
0x0232	-46.250	0x0261	-52.125	0x0290	-58.000	0x02BF	-63.875	0x02EE	-69.750	0x031D	-75.625

Table 12. Master Volume Table (continued)

VALUE	LEVEL	VALUE	LEVEL	VALUE	LEVEL	VALUE	LEVEL	VALUE	LEVEL	VALUE	LEVEL
0x031E	-75.750	0x0344	-80.500	0x036A	-85.250	0x0390	-90.000	0x03B6	-94.750	0x03DC	-99.500
0x031F	-75.875	0x0345	-80.625	0x036B	-85.375	0x0391	-90.125	0x03B7	-94.875	0x03DD	-99.625
0x0320	-76.000	0x0346	-80.750	0x036C	-85.500	0x0392	-90.250	0x03B8	-95.000	0x03DE	-99.750
0x0321	-76.125	0x0347	-80.875	0x036D	-85.625	0x0393	-90.375	0x03B9	-95.125	0x03DF	-99.875
0x0322	-76.250	0x0348	-81.000	0x036E	-85.750	0x0394	-90.500	0x03BA	-95.250	0x03E0	-100.000
0x0323	-76.375	0x0349	-81.125	0x036F	-85.875	0x0395	-90.625	0x03BB	-95.375	0x03E1	-100.125
0x0324	-76.500	0x034A	-81.250	0x0370	-86.000	0x0396	-90.750	0x03BC	-95.500	0x03E2	-100.250
0x0325	-76.625	0x034B	-81.375	0x0371	-86.125	0x0397	-90.875	0x03BD	-95.625	0x03E3	-100.375
0x0326	-76.750	0x034C	-81.500	0x0372	-86.250	0x0398	-91.000	0x03BE	-95.750	0x03E4	-100.500
0x0327	-76.875	0x034D	-81.625	0x0373	-86.375	0x0399	-91.125	0x03BF	-95.875	0x03E5	-100.625
0x0328	-77.000	0x034E	-81.750	0x0374	-86.500	0x039A	-91.250	0x03C0	-96.000	0x03E6	-100.750
0x0329	-77.125	0x034F	-81.875	0x0375	-86.625	0x039B	-91.375	0x03C1	-96.125	0x03E7	-100.875
0x032A	-77.250	0x0350	-82.000	0x0376	-86.750	0x039C	-91.500	0x03C2	-96.250	0x03E8	-101.000
0x032B	-77.375	0x0351	-82.125	0x0377	-86.875	0x039D	-91.625	0x03C3	-96.375	0x03E9	-101.125
0x032C	-77.500	0x0352	-82.250	0x0378	-87.000	0x039E	-91.750	0x03C4	-96.500	0x03EA	-101.250
0x032D	-77.625	0x0353	-82.375	0x0379	-87.125	0x039F	-91.875	0x03C5	-96.625	0x03EB	-101.375
0x032E	-77.750	0x0354	-82.500	0x037A	-87.250	0x03A0	-92.000	0x03C6	-96.750	0x03EC	-101.500
0x032F	-77.875	0x0355	-82.625	0x037B	-87.375	0x03A1	-92.125	0x03C7	-96.875	0x03ED	-101.625
0x0330	-78.000	0x0356	-82.750	0x037C	-87.500	0x03A2	-92.250	0x03C8	-97.000	0x03EE	-101.750
0x0331	-78.125	0x0357	-82.875	0x037D	-87.625	0x03A3	-92.375	0x03C9	-97.125	0x03EF	-101.875
0x0332	-78.250	0x0358	-83.000	0x037E	-87.750	0x03A4	-92.500	0x03CA	-97.250	0x03F0	-102.000
0x0333	-78.375	0x0359	-83.125	0x037F	-87.875	0x03A5	-92.625	0x03CB	-97.375	0x03F1	-102.125
0x0334	-78.500	0x035A	-83.250	0x0380	-88.000	0x03A6	-92.750	0x03CC	-97.500	0x03F2	-102.250
0x0335	-78.625	0x035B	-83.375	0x0381	-88.125	0x03A7	-92.875	0x03CD	-97.625	0x03F3	-102.375
0x0336	-78.750	0x035C	-83.500	0x0382	-88.250	0x03A8	-93.000	0x03CE	-97.750	0x03F4	-102.500
0x0337	-78.875	0x035D	-83.625	0x0383	-88.375	0x03A9	-93.125	0x03CF	-97.875	0x03F5	-102.625
0x0338	-79.000	0x035E	-83.750	0x0384	-88.500	0x03AA	-93.250	0x03D0	-98.000	0x03F6	-102.750
0x0339	-79.125	0x035F	-83.875	0x0385	-88.625	0x03AB	-93.375	0x03D1	-98.125	0x03F7	-102.875
0x033A	-79.250	0x0360	-84.000	0x0386	-88.750	0x03AC	-93.500	0x03D2	-98.250	0x03F8	-103.000
0x033B	-79.375	0x0361	-84.125	0x0387	-88.875	0x03AD	-93.625	0x03D3	-98.375	0x03F9	-103.125
0x033C	-79.500	0x0362	-84.250	0x0388	-89.000	0x03AE	-93.750	0x03D4	-98.500	0x03FA	-103.250
0x033D	-79.625	0x0363	-84.375	0x0389	-89.125	0x03AF	-93.875	0x03D5	-98.625	0x03FB	-103.375
0x033E	-79.750	0x0364	-84.500	0x038A	-89.250	0x03B0	-94.000	0x03D6	-98.750	0x03FC	-103.500
0x033F	-79.875	0x0365	-84.625	0x038B	-89.375	0x03B1	-94.125	0x03D7	-98.875	0x03FD	-103.625
0x0340	-80.000	0x0366	-84.750	0x038C	-89.500	0x03B2	-94.250	0x03D8	-99.000	0x03FE	-103.750
0x0341	-80.250	0x0367	-84.875	0x038D	-89.625	0x03B3	-94.375	0x03D9	-99.125	0x03FF	Mute
0x0341	-80.250	0x0368	-85.000	0x038E	-89.750	0x03B4	-94.500	0x03DA	-99.250		
0x0343	-80.375	0x0369	-85.125	0x038F	-89.875	0x03B5	-94.625	0x03DB	-99.375		

10.6.9 Volume Configuration Register (0x0E)

Bits D2–D0: Volume slew rate (used to control volume change and MUTE ramp rates). These bits control the number of steps in a volume ramp. Volume steps occur at a rate that depends on the sample rate of the I²S data as follows:

Sample rate (kHz)	Approximate ramp rate
8/16/32	125 μs/step
11.025/22.05/44.1	90.7 μs/step
12/24/48	83.3 μs/step

In two-band DRC, register 0x0A should be set to 0x30 and register 0x0E bits 6 and 5 should be set to 1.

Table 13. Volume Configuration Register (0x0E)

D7	D6	D5	D4	D3	D2	D1	D0	FUNCTION
1	–	–	–	–	–	–	–	Reserved ⁽¹⁾
–	0	–	–	–	–	–	–	DRC2 volume 1 (ch4) from I ² C register 0x08
–	1	–	–	–	–	–	–	DRC2 volume 1 (ch4) from I²C register 0x0A⁽¹⁾
–	–	0	–	–	–	–	–	DRC2 volume 2 (ch3) from I ² C register 0x09
–	–	1	–	–	–	–	–	DRC2 volume 2 (ch3) from I²C register 0x0A⁽¹⁾
–	–	–	1	0	–	–	–	Reserved ⁽¹⁾
–	–	–	–	–	0	0	0	Volume slew 512 steps (43 ms volume ramp time at 48 kHz)⁽¹⁾
–	–	–	–	–	0	0	1	Volume slew 1024 steps (85-ms volume ramp time at 48 kHz)
–	–	–	–	–	0	1	0	Volume slew 2048 steps (171-ms volume ramp time at 48 kHz)
–	–	–	–	–	0	1	1	Volume slew 256 steps (21-ms volume ramp time at 48 kHz)
–	–	–	–	–	1	X	X	Reserved

(1) Default values are in **bold**.

10.6.10 Modulation Limit Register (0x10)

Table 14. Modulation Limit Register (0x10)

D7	D6	D5	D4	D3	D2	D1	D0	MODULATION LIMIT
0	0	0	0	0	–	–	–	Reserved
–	–	–	–	–	0	0	0	99.2%
–	–	–	–	–	0	0	1	98.4%
–	–	–	–	–	0	1	0	97.7%⁽¹⁾
–	–	–	–	–	0	1	1	96.9%
–	–	–	–	–	1	0	0	96.1%
–	–	–	–	–	1	0	1	95.3%
–	–	–	–	–	1	1	0	94.5%
–	–	–	–	–	1	1	1	93.8%

(1) Default values are in **bold**.

10.6.11 Interchannel Delay Registers (0x11, 0x12, 0x13, and 0x14)

Internal PWM channels 1, 2, $\bar{1}$, and $\bar{2}$ are mapped into registers 0x11, 0x12, 0x13, and 0x14.

Table 15. Channel Interchannel Delay Register Format

BITS DEFINITION	D7	D6	D5	D4	D3	D2	D1	D0	FUNCTION
	0	0	0	0	0	0	–	–	Minimum absolute delay, 0 DCLK cycles
	0	1	1	1	1	1	–	–	Maximum positive delay, 31×4 DCLK cycles
	1	0	0	0	0	0	–	–	Maximum negative delay, -32×4 DCLK cycles
							0	0	Reserved
SUBADDRESS	D7	D6	D5	D4	D3	D2	D1	D0	Delay = (value) \times 4 DCLKs
0x11	1	0	1	0	1	1	–	–	Default value for channel 1⁽¹⁾
0x12	0	1	0	1	0	1	–	–	Default value for channel 2⁽¹⁾
0x13	1	0	1	0	1	1	–	–	Default value for channel 1⁽¹⁾
0x14	0	1	0	1	0	1	–	–	Default value for channel 2⁽¹⁾

(1) Default values are in **bold**.

ICD settings have high impact on audio performance (for example, dynamic range, THD, crosstalk, and so forth). Therefore, appropriate ICD settings must be used. By default, the device has ICD settings for the AD mode. If used in BD mode, then update these registers before coming out of all-channel shutdown.

Table 16. ICD Settings

MODE	AD MODE	BD MODE
0x11	AC	B8
0x12	54	60
0x13	AC	A0
0x14	54	48

10.6.12 PWM Shutdown Group Register (0x19)

Settings of this register determine which PWM channels are active. The value should be 0x30 for BTL mode and 0x3A for PBTTL mode. The default value of this register is 0x30. The functionality of this register is tied to the state of bit D5 in the system control register.

This register defines which channels belong to the shutdown group (SDG). If a 1 is set in the shutdown group register, that particular channel is **not** started following an exit *out of all-channel shutdown* command (if bit D5 is set to 0 in system control register 2, 0x05).

Table 17. PWM Shutdown Group Register (0x19)

D7	D6	D5	D4	D3	D2	D1	D0	FUNCTION
0	–	–	–	–	–	–	–	Reserved ⁽¹⁾
–	0	–	–	–	–	–	–	Reserved ⁽¹⁾
–	–	1	–	–	–	–	–	Reserved ⁽¹⁾
–	–	–	1	–	–	–	–	Reserved ⁽¹⁾
–	–	–	–	0	–	–	–	PWM channel 4 does not belong to shutdown group. ⁽¹⁾
–	–	–	–	1	–	–	–	PWM channel 4 belongs to shutdown group.
–	–	–	–	–	0	–	–	PWM channel 3 does not belong to shutdown group. ⁽¹⁾
–	–	–	–	–	1	–	–	PWM channel 3 belongs to shutdown group.
–	–	–	–	–	–	0	–	PWM channel 2 does not belong to shutdown group. ⁽¹⁾
–	–	–	–	–	–	1	–	PWM channel 2 belongs to shutdown group.
–	–	–	–	–	–	–	0	PWM channel 1 does not belong to shutdown group. ⁽¹⁾
–	–	–	–	–	–	–	1	PWM channel 1 belongs to shutdown group.

(1) Default values are in **bold**.

10.6.13 Start/Stop Period Register (0x1A)

This register is used to control the soft-start and soft-stop period following an enter or exit all-channel shutdown command or change in the PDN state. This helps reduce pops and clicks at start-up and shutdown. The times are only approximate and vary depending on device activity level and I²S clock stability.

Table 18. Start/Stop Period Register (0x1A)

D7	D6	D5	D4	D3	D2	D1	D0	FUNCTION
0	–	–	–	–	–	–	–	SSTIMER enabled ⁽¹⁾
1	–	–	–	–	–	–	–	SSTIMER disabled
–	0	0	–	–	–	–	–	Reserved ⁽²⁾
–	–	–	0	0	–	–	–	No 50% duty cycle start/stop period
–	–	–	0	1	0	0	0	16.5-ms 50% duty cycle start/stop period
–	–	–	0	1	0	0	1	23.9-ms 50% duty cycle start/stop period
–	–	–	0	1	0	1	0	31.4-ms 50% duty cycle start/stop period
–	–	–	0	1	0	1	1	40.4-ms 50% duty cycle start/stop period
–	–	–	0	1	1	0	0	53.9-ms 50% duty cycle start/stop period
–	–	–	0	1	1	0	1	70.3-ms 50% duty cycle start/stop period
–	–	–	0	1	1	1	0	94.2-ms 50% duty cycle start/stop period
–	–	–	0	1	1	1	1	125.7-ms 50% duty cycle start/stop period ⁽²⁾
–	–	–	1	0	0	0	0	164.6-ms 50% duty cycle start/stop period
–	–	–	1	0	0	0	1	239.4-ms 50% duty cycle start/stop period
–	–	–	1	0	0	1	0	314.2-ms 50% duty cycle start/stop period
–	–	–	1	0	0	1	1	403.9-ms 50% duty cycle start/stop period
–	–	–	1	0	1	0	0	538.6-ms 50% duty cycle start/stop period
–	–	–	1	0	1	0	1	703.1-ms 50% duty cycle start/stop period
–	–	–	1	0	1	1	0	942.5-ms 50% duty cycle start/stop period
–	–	–	1	0	1	1	1	1256.6-ms 50% duty cycle start/stop period
–	–	–	1	1	0	0	0	1728.1-ms 50% duty cycle start/stop period
–	–	–	1	1	0	0	1	2513.6-ms 50% duty cycle start/stop period
–	–	–	1	1	0	1	0	3299.1-ms 50% duty cycle start/stop period
–	–	–	1	1	0	1	1	4241.7-ms 50% duty cycle start/stop period
–	–	–	1	1	1	0	0	5655.6-ms 50% duty cycle start/stop period
–	–	–	1	1	1	0	1	7383.7-ms 50% duty cycle start/stop period
–	–	–	1	1	1	1	0	9897.3-ms 50% duty cycle start/stop period
–	–	–	1	1	1	1	1	13,196.4-ms 50% duty cycle start/stop period

(1) Default values are in **bold**.

(2) Default values are in **bold**.

10.6.14 Oscillator Trim Register (0x1B)

The TAS5727 PWM processor contains an internal oscillator to support autodetect of I²S clock rates. This reduces system cost because an external reference is not required. Currently, TI recommends a reference resistor value of 18.2 kΩ (1%). This should be connected between OSC_RES and DVSSO.

Writing 0x00 to register 0x1B enables the trim that was programmed at the factory.

Note that trim must always be run following reset of the device.

Table 19. Oscillator Trim Register (0x1B)

D7	D6	D5	D4	D3	D2	D1	D0	FUNCTION
1	–	–	–	–	–	–	–	Reserved ⁽¹⁾
–	0	–	–	–	–	–	–	Oscillator trim not done (read-only) ⁽¹⁾
–	1	–	–	–	–	–	–	Oscillator trim done (read only)
–	–	0	0	0	0	–	–	Reserved ⁽¹⁾
–	–	–	–	–	–	0	–	Select factory trim (Write a 0 to select factory trim; default is 1.)
–	–	–	–	–	–	1	–	Factory trim disabled ⁽¹⁾
–	–	–	–	–	–	–	0	Reserved ⁽¹⁾

(1) Default values are in **bold**.

10.6.15 BKND_ERR Register (0x1C)

When a back-end error signal is received from the internal power stage, the power stage is reset, stopping all PWM activity. Subsequently, the modulator waits approximately for the time listed in [Table 20](#) before attempting to re-start the power stage.

Table 20. BKND_ERR Register (0x1C)⁽¹⁾

D7	D6	D5	D4	D3	D2	D1	D0	FUNCTION
0	0	0	0	0	0	0	X	Reserved
–	–	–	–	0	0	1	0	Set back-end reset period to 299 ms ⁽²⁾
–	–	–	–	0	0	1	1	Set back-end reset period to 449 ms
–	–	–	–	0	1	0	0	Set back-end reset period to 598 ms
–	–	–	–	0	1	0	1	Set back-end reset period to 748 ms
–	–	–	–	0	1	1	0	Set back-end reset period to 898 ms
–	–	–	–	0	1	1	1	Set back-end reset period to 1047 ms
–	–	–	–	1	0	0	0	Set back-end reset period to 1197 ms
–	–	–	–	1	0	0	1	Set back-end reset period to 1346 ms
–	–	–	–	1	0	1	X	Set back-end reset period to 1496 ms
–	–	–	–	1	1	X	X	Set back-end reset period to 1496 ms

(1) This register can be written only with a non-reserved value. Also this register can be written once after the reset.

(2) Default values are in **bold**.

10.6.16 Input Multiplexer Register (0x20)

This register controls the modulation scheme (AD or BD mode) as well as the routing of I²S audio to the internal channels.

Table 21. Input Multiplexer Register (0x20)

D31	D30	D29	D28	D27	D26	D25	D24	FUNCTION
0	0	0	0	0	0	0	0	Reserved ⁽¹⁾
D23	D22	D21	D20	D19	D18	D17	D16	FUNCTION
0	–	–	–	–	–	–	–	Channel-1 AD mode ⁽¹⁾
1	–	–	–	–	–	–	–	Channel-1 BD mode
–	0	0	0	–	–	–	–	SDIN-L to channel 1 ⁽¹⁾
–	0	0	1	–	–	–	–	SDIN-R to channel 1
–	0	1	0	–	–	–	–	Reserved
–	0	1	1	–	–	–	–	Reserved
–	1	0	0	–	–	–	–	Reserved
–	1	0	1	–	–	–	–	Reserved
–	1	1	0	–	–	–	–	Ground (0) to channel 1
–	1	1	1	–	–	–	–	Reserved
–	–	–	–	0	–	–	–	Channel 2 AD mode ⁽¹⁾
–	–	–	–	1	–	–	–	Channel 2 BD mode
–	–	–	–	–	0	0	0	SDIN-L to channel 2
–	–	–	–	–	0	0	1	SDIN-R to channel 2 ⁽¹⁾
–	–	–	–	–	0	1	0	Reserved
–	–	–	–	–	0	1	1	Reserved
–	–	–	–	–	1	0	0	Reserved
–	–	–	–	–	1	0	1	Reserved
–	–	–	–	–	1	1	0	Ground (0) to channel 2
–	–	–	–	–	1	1	1	Reserved
D15	D14	D13	D12	D11	D10	D9	D8	FUNCTION
0	1	1	1	0	1	1	1	Reserved ⁽¹⁾
D7	D6	D5	D4	D3	D2	D1	D0	FUNCTION
0	1	1	1	0	0	1	0	Reserved ⁽¹⁾

(1) Default values are in **bold**.

10.6.17 Channel 4 Source Select Register (0x21)

This register selects the channel 4 source.

Table 22. Subchannel Control Register (0x21)

D31	D30	D29	D28	D27	D26	D25	D24	FUNCTION
0	0	0	0	0	0	0	0	Reserved ⁽¹⁾
D23	D22	D21	D20	D19	D18	D17	D16	FUNCTION
0	0	0	0	0	0	0	0	Reserved ⁽¹⁾
D15	D14	D13	D12	D11	D10	D9	D8	FUNCTION
0	1	0	0	0	0	1	–	Reserved ⁽¹⁾
–	–	–	–	–	–	–	0	(L + R)/2
–	–	–	–	–	–	–	1	Left-channel post-BQ ⁽¹⁾
D7	D6	D5	D4	D3	D2	D1	D0	FUNCTION
0	0	0	0	0	0	1	1	Reserved ⁽¹⁾

(1) Default values are in **bold**.

10.6.18 PWM Output MUX Register (0x25)

This DAP output mux selects which internal PWM channel is output to the external pins. Any channel can be output to any external output pin.

Bits D21–D20: Selects which PWM channel is output to OUT_A

Bits D17–D16: Selects which PWM channel is output to OUT_B

Bits D13–D12: Selects which PWM channel is output to OUT_C

Bits D09–D08: Selects which PWM channel is output to OUT_D

Note that channels are encoded so that channel 1 = 0x00, channel 2 = 0x01, ..., channel 4 = 0x03.

Table 23. PWM Output Mux Register (0x25)

D31	D30	D29	D28	D27	D26	D25	D24	FUNCTION
0	0	0	0	0	0	0	1	Reserved ⁽¹⁾
D23	D22	D21	D20	D19	D18	D17	D16	FUNCTION
0	0	–	–	–	–	–	–	Reserved ⁽¹⁾
–	–	0	0	–	–	–	–	Multiplex channel 1 to OUT_A ⁽¹⁾
–	–	0	1	–	–	–	–	Multiplex channel 2 to OUT_A
–	–	1	0	–	–	–	–	Multiplex channel 1 to OUT_A
–	–	1	1	–	–	–	–	Multiplex channel 2 to OUT_A
–	–	–	–	0	0	–	–	Reserved ⁽¹⁾
–	–	–	–	–	–	0	0	Multiplex channel 1 to OUT_B
–	–	–	–	–	–	0	1	Multiplex channel 2 to OUT_B
–	–	–	–	–	–	1	0	Multiplex channel 1 to OUT_B ⁽¹⁾
–	–	–	–	–	–	1	1	Multiplex channel 2 to OUT_B

(1) Default values are in **bold**.

Table 23. PWM Output Mux Register (0x25) (continued)

D15	D14	D13	D12	D11	D10	D9	D8	FUNCTION
0	0	–	–	–	–	–	–	Reserved ⁽¹⁾
–	–	0	0	–	–	–	–	Multiplex channel 1 to OUT_C
–	–	0	1	–	–	–	–	Multiplex channel 2 to OUT_C⁽¹⁾
–	–	1	0	–	–	–	–	Multiplex channel 1 to OUT_C
–	–	1	1	–	–	–	–	Multiplex channel 2 to OUT_C
–	–	–	–	0	0	–	–	Reserved ⁽¹⁾
–	–	–	–	–	–	0	0	Multiplex channel 1 to OUT_D
–	–	–	–	–	–	0	1	Multiplex channel 2 to OUT_D
–	–	–	–	–	–	1	0	Multiplex channel 1 to OUT_D
–	–	–	–	–	–	1	1	Multiplex channel 2 to OUT_D⁽¹⁾
D7	D6	D5	D4	D3	D2	D1	D0	FUNCTION
0	1	0	0	0	1	0	1	Reserved ⁽¹⁾

10.6.19 DRC Control Register (0x46)
Table 24. DRC Control Register (0x46)

D31	D30	D29	D28	D27	D26	D25	D24	FUNCTION
0	0	0	0	0	0	0	0	Reserved ⁽¹⁾
D23	D22	D21	D20	D19	D18	D17	D16	FUNCTION
0	0	0	0	0	0	0	0	Reserved ⁽¹⁾
D15	D14	D13	D12	D11	D10	D9	D8	FUNCTION
0	0	0	0	0	0	0	0	Reserved ⁽¹⁾
D7	D6	D5	D4	D3	D2	D1	D0	FUNCTION
0	0	–	–	–	–	–	–	Reserved ⁽¹⁾
–	–	0	–	–	–	–	–	Reserved
–	–	1	–	–	–	–	–	Reserved
–	–	–	0	–	–	–	–	Reserved ⁽¹⁾
–	–	–	–	0	–	–	–	Reserved ⁽¹⁾
–	–	–	–	–	0	–	–	Reserved ⁽¹⁾
–	–	–	–	–	–	0	–	DRC2 turned OFF⁽¹⁾
–	–	–	–	–	–	–	1	DRC2 turned ON
–	–	–	–	–	–	–	0	DRC1 turned OFF⁽¹⁾
–	–	–	–	–	–	–	1	DRC1 turned ON

 (1) Default values are in **bold**.

10.6.20 PWM Switching Rate Control Register (0x4F)

PWM switching rate should be selected through the register 0x4F before coming out of all-channel shutdown.

Table 25. PWM Switching Rate Control Register (0x4F)

D31	D30	D29	D28	D27	D26	D25	D24	FUNCTION
0	0	0	0	0	0	0	0	Reserved ⁽¹⁾
D23	D22	D21	D20	D19	D18	D17	D16	FUNCTION
0	0	0	0	0	0	0	0	Reserved ⁽¹⁾
D15	D14	D13	D12	D11	D10	D9	D8	FUNCTION
0	0	0	0	0	0	0	0	Reserved ⁽¹⁾
D7	D6	D5	D4	D3	D2	D1	D0	FUNCTION
–	–	0	0	–	–	–	–	Reserved ⁽¹⁾
–	–	–	–	0	1	1	0	SRC = 6 ⁽¹⁾
–	–	–	–	0	1	1	1	SRC = 7
–	–	–	–	1	0	0	0	SRC = 8
–	–	–	–	1	0	0	1	SRC = 9
–	–	–	–	1	0	1	0	Reserved
–	–	–	–	1	1	–	–	Reserved

(1) Default values are in **bold**.

10.6.21 Bank Switch and EQ Control (0x50)

Table 26. Bank Switching Command (0x50)

D31	D30	D29	D28	D27	D26	D25	D24	FUNCTION
0	0	0	0	0	0	0	0	Reserved ⁽¹⁾
D23	D22	D21	D20	D19	D18	D17	D16	FUNCTION
0	0	0	0	0	0	0	0	Reserved ⁽¹⁾
D15	D14	D13	D12	D11	D10	D9	D8	FUNCTION
0	0	0	0	0	0	0	0	Reserved ⁽¹⁾
D7	D6	D5	D4	D3	D2	D1	D0	FUNCTION
0								EQ ON ⁽¹⁾
1	–	–	–	–	–	–	–	EQ OFF (bypass BQ 0–7 of channels 1 and 2)
–	0	–	–	–	–	–	–	Reserved ⁽¹⁾
–	–	0	–	–	–	–	–	Ignore bank-mapping in bits D31–D8. Use default mapping. ⁽¹⁾
–	–	1	–	–	–	–	–	Use bank-mapping in bits D31–D8.
–	–	–	0	–	–	–	–	L and R can be written independently. ⁽¹⁾
–	–	–	1	–	–	–	–	L and R are ganged for EQ biquads; a write to the left-channel biquad is also written to the right-channel biquad. (0x29–0x2F is ganged to 0x30–0x36. Also, 0x58–0x5B is ganged to 0x5C–0x5F.
–	–	–	–	0	–	–	–	Reserved ⁽¹⁾
–	–	–	–	–	0	0	0	No bank switching. All updates to DAP ⁽¹⁾
–	–	–	–	–	0	0	1	Configure bank 1 (32 kHz by default)
–	–	–	–	–	0	1	X	Reserved
–	–	–	–	–	1	X	X	Reserved

(1) Default values are in **bold**.

11 Application and Implementation

NOTE

Information in the following applications sections is not part of the TI component specification, and TI does not warrant its accuracy or completeness. TI's customers are responsible for determining suitability of components for their purposes. Customers should validate and test their design implementation to confirm system functionality.

11.1 Application Information

The typical connection diagram highlights the required external components and system level connections for proper operation of the device in several popular system examples.

Each of these configurations can be realized using the Evaluation Module (EVM) for the device. These flexible modules allow full evaluation of the device in the most common modes of operation. Any design variation can be supported by TI through schematic and layout reviews. Visit <http://e2e.ti.com> for design assistance and join the audio amplifier discussion forum for additional information.

11.2 Typical Applications

11.2.1 Stereo Stereo Bridge Tied Load Application

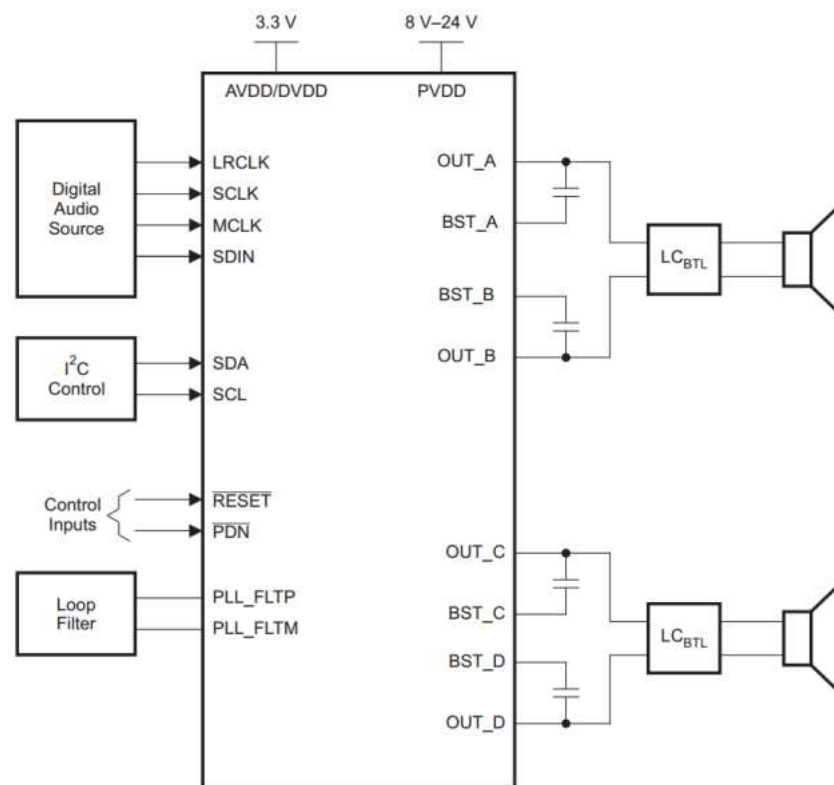

Copyright © 2016 Texas Instruments Incorporated

Figure 40. TAS5727 Stereo Application

11.2.1.1 Design Requirements

Table 27 lists the design parameters for this example.

Table 27. Design Parameters

PARAMETER	EXAMPLE
Low Power Supply	3.3 V
High Power Supply	8 V to 26 V
Host Processor	I ² S Compliant Master
	I ² C Compliant Master
	GPIO Control
Output Filters	Inductor-Capacitor Low-Pass Filter ⁽¹⁾
Speaker	4-Ω minimum

(1) Refer to SLOA119 for a detailed description of the filter design.

11.2.1.2 Detailed Design Procedure

11.2.1.2.1 Component Selection and Hardware Connections

The typical connections required for proper operation of the device can be found on the TAS5727 User’s Guide (SLOU346). The device was tested this list of components, deviation from this typical application components unless recommended by this document may produce unwanted results, which could range from degradation of audio performance to destructive failure of the device. The application report Class-D LC Filter Design (SLOA119) offers a detailed description on proper component selection and design of the output filter based upon the modulation used, desired load, and response.

11.2.1.2.2 I²C Pullup Resistors

Customary pullup resistors are required on the SCL and SDA signal lines. These pullups are not shown in the typical application circuits, because they are shared by all of the devices on the I²C bus, and are considered to be part of the associated passive components for the System Processor. These resistor values should be chosen per the guidance provided in the I²C Specification.

11.2.1.2.3 Digital I/O Connectivity

The digital I/O lines of the TAS5727 are described in previous sections. As discussed, whenever a static digital pin (that is a pin that is hardwired to be HIGH or LOW) is required to be pulled HIGH, it should be connected to DVDD through a pullup resistor to control the slew rate of the voltage presented to the digital I/O pins. It is not, however, necessary to have a separate pullup resistor for each static digital I/O line. Instead, a single resistor can be used to tie all static I/O lines HIGH to reduce BOM count.

11.2.1.2.4 Recommended Start-Up and Shutdown Procedures

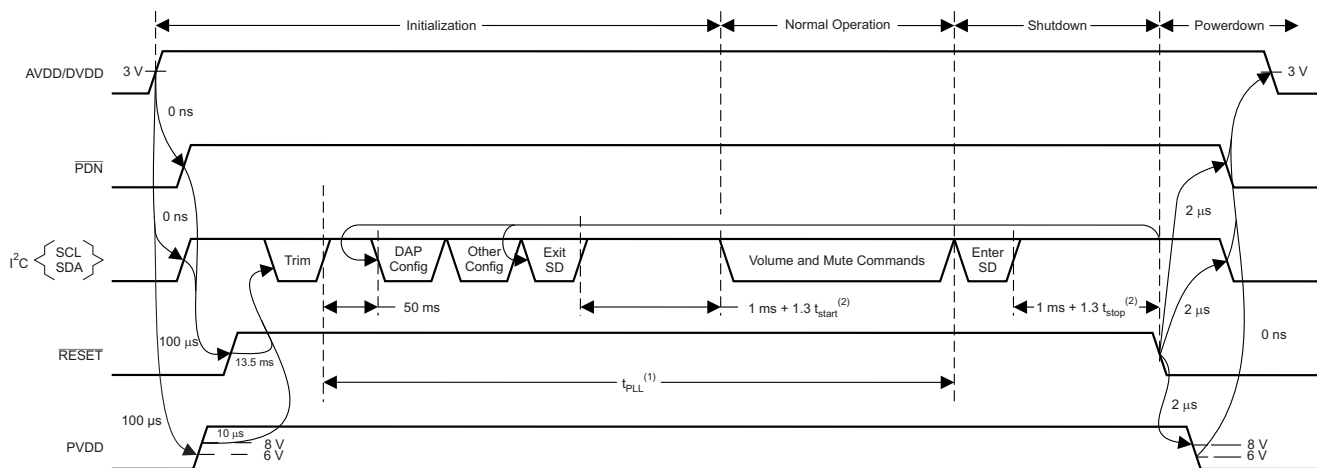

(1) t_{PLL} has to be greater than 240 ms + 1.3 t_{start}. This constraint only applies to the first trim command following AVDD/DVDD power-up. It does not apply to trim commands following subsequent resets.
 (2) t_{start}/t_{stop} = PWM start/stop time as defined in register 0X1A

T0419-06

Figure 41. Recommended Command Sequence

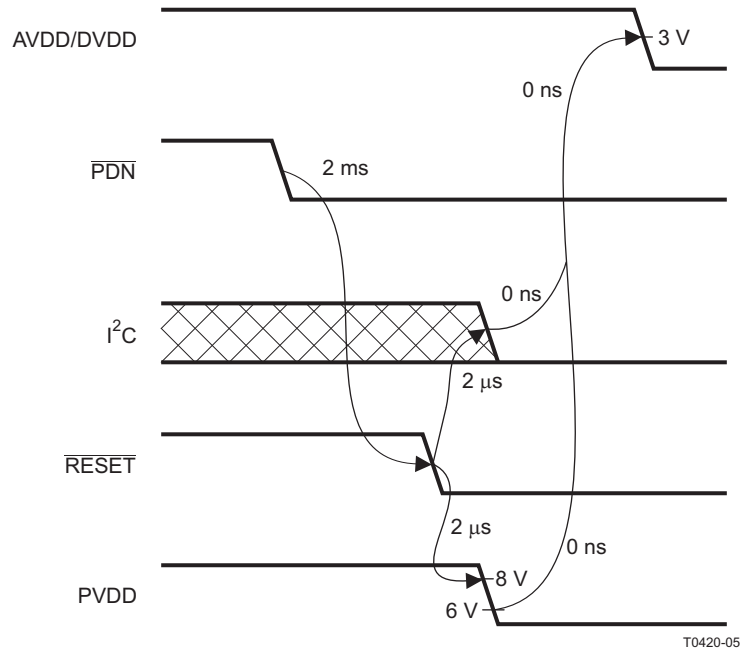
Figure 42. Power-Loss Sequence

11.2.1.2.4.1 Initialization Sequence

Use the following sequence to power up and initialize the device:

1. Hold all digital inputs low and ramp up AVDD/DVDD to at least 3 V.
2. Initialize digital inputs and PVDD supply as follows:
 - Drive $\overline{\text{RESET}} = 0$, $\overline{\text{PDN}} = 1$, and other digital inputs to their desired state while ensuring that all are never more than 2.5 V above AVDD/DVDD. Wait at least 100 μs, drive $\overline{\text{RESET}} = 1$, and wait at least another 13.5 ms.
 - Ramp up PVDD to at least 8 V while ensuring that it remains below 6 V for at least 100 μs after AVDD/DVDD reaches 3 V. Then wait at least another 10 μs.
3. Trim oscillator (write 0x00 to register 0x1B) and wait at least 50 ms.
4. Configure the DAP through I²C (see User's Guide for typical values).
5. Configure remaining registers.
6. Exit shutdown (sequence defined below).

11.2.1.2.4.2 Normal Operation

The following are the only events supported during normal operation:

1. Writes to master/channel volume registers
2. Writes to soft-mute register
3. Enter and exit shutdown (sequence defined below)

NOTE

Event 3 is not supported for $240 \text{ ms} + 1.3 \times t_{\text{start}}$ after trim following AVDD/DVDD power-up ramp (where t_{start} is specified by register 0x1A).

11.2.1.2.4.3 Shutdown Sequence

Enter:

1. Write 0x40 to register 0x05.
2. Wait at least $1 \text{ ms} + 1.3 \times t_{\text{stop}}$ (where t_{stop} is specified by register 0x1A).

3. If desired, reconfigure by returning to step 4 of initialization sequence.

Exit:

1. Write 0x00 to register 0x05 (exit shutdown command may not be serviced for as much as 240 ms after trim following AVDD/DVDD power-up ramp).
2. Wait at least 1 ms + 1.3 × t_{start} (where t_{start} is specified by register 0x1A).
3. Proceed with normal operation.

11.2.1.2.4.4 Power-Down Sequence

Use the following sequence to power down the device and its supplies:

1. If time permits, enter shutdown (sequence defined above); else, in case of sudden power loss, assert $\overline{\text{PDN}} = 0$ and wait at least 2 ms.
2. Assert $\overline{\text{RESET}} = 0$.
3. Drive digital inputs low and ramp down PVDD supply as follows:
 - Drive all digital inputs low after $\overline{\text{RESET}}$ has been low for at least 2 μs .
 - Ramp down PVDD while ensuring that it remains above 8 V until $\overline{\text{RESET}}$ has been low for at least 2 μs .
4. Ramp down AVDD/DVDD while ensuring that it remains above 3 V until PVDD is below 6 V and that it is never more than 2.5 V below the digital inputs.

11.2.1.3 Application Curves

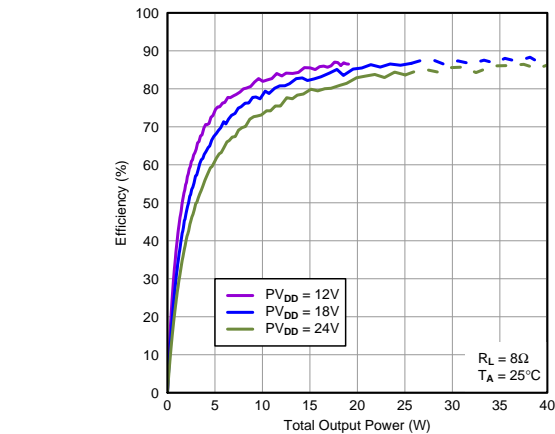
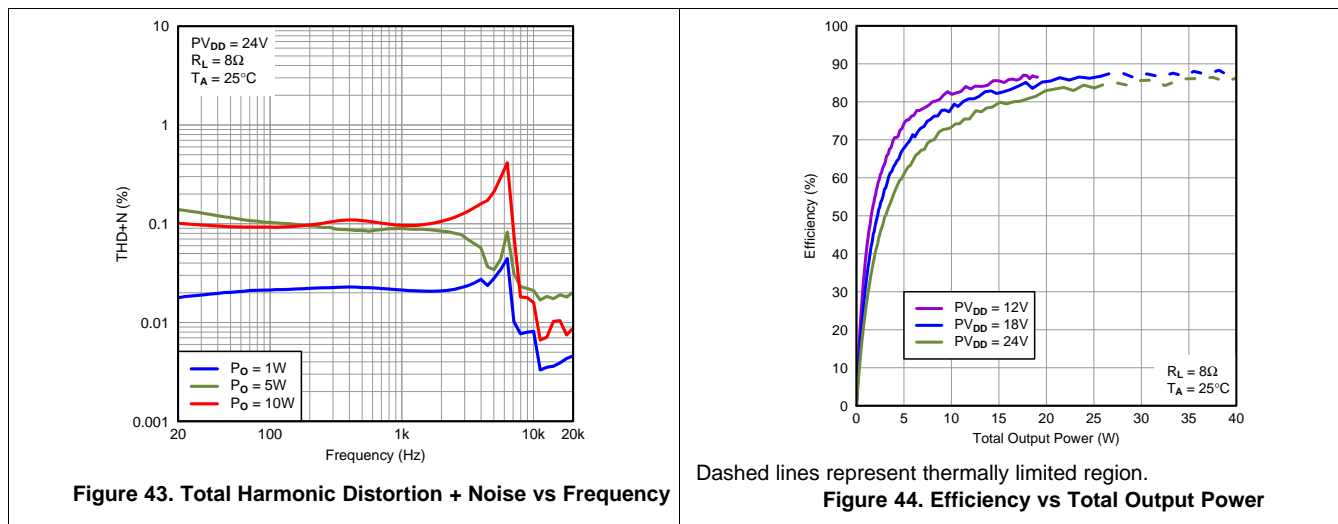

Dashed lines represent thermally limited region.

11.2.2 Mono Parallel Bridge Tied Load Application

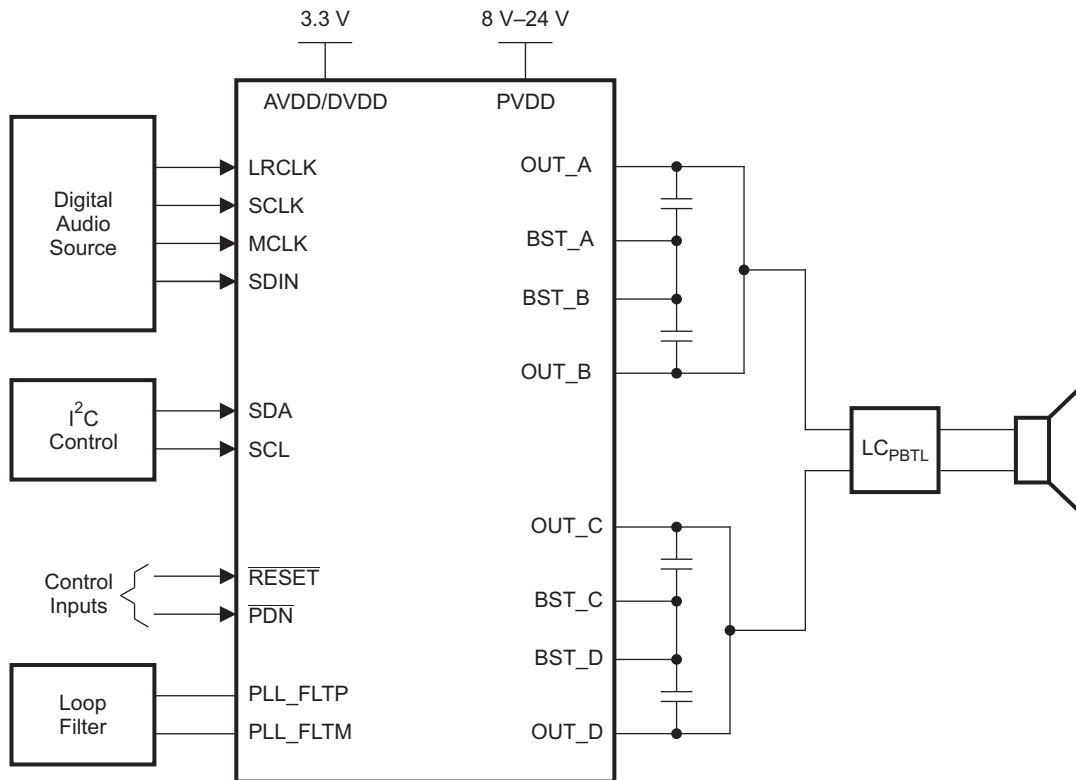

B0264-26

Copyright © 2016 Texas Instruments Incorporated

Figure 45. TAS5727 Mono Application

11.2.2.1 Design Requirements

Table 28 lists the design parameters for this example.

Table 28. Design Parameters

PARAMETER	EXAMPLE
Low Power Supply	3.3 V
High Power Supply	8 V to 26 V
Host Processor	I ² S Compliant Master
	I ² C Compliant Master
	GPIO Control
Output Filters	Inductor-Capacitor Low-Pass Filter ⁽¹⁾
Speaker	2-Ω minimum

(1) Refer to SLOA119 for a detailed description of the filter design.

11.2.2.2 Detailed Design Procedure

Refer to [Detailed Design Procedure](#).

11.2.2.3 Application Curves

Refer to [Application Curves](#).

12 Power Supply Recommendations

The TAS5727 requires two power supplies: a low voltage, 3.3 V nominal for the pins DVDD, AVDD, and DRVDD, and a high power supply of 8 V to 24 V for the pin PVDD. There is no requirement for power-up sequencing of low and high power supplies; however, TI recommends putting the PDN pin to low before removing the low voltage power supplies to protect the outputs.

12.1 DVDD and AVDD Supplies

The AVDD Supply is used to power the analog internal circuit of the device, and needs a well-regulated and filtered 3.3-V supply voltage. The DVDD Supply is used to power the digital circuitry. DVDD needs a well-regulated and filtered 3.3-V supply voltage.

12.2 PVDD Power Supply

The TAS5727 class-D audio amplifier requires adequate power supply decoupling to ensure the output total harmonic distortion (THD) and noise is as low as possible. A good low equivalent-series-resistance (ESR) ceramic capacitor, typically 1 μF , placed as close as possible to the device PVDD leads works best. For filtering lower-frequency noise signals, TI recommends placing a 10 μF or greater capacitor near the audio power amplifier.

13 Layout

13.1 Layout Guidelines

Class-D switching edges are fast and switched currents are high, so it is necessary to take care when planning the layout of the printed-circuit board. The following suggestions help meet audio, thermal, and EMC requirements.

- TAS5727 uses the PCB for heat sinking; therefore, the PowerPAD™ needs to be soldered to the PCB and adequate copper area and copper vias connecting the top, bottom and internal layers should be used.
- Decoupling capacitors: the high-frequency decoupling capacitors should be placed as close to the supply pins as possible; on the TAS5727, a 1- μF high-quality ceramic capacitor is used. Large (10- μF or greater) bulk power supply decoupling capacitors should be placed near the TAS5727 on the PVDD supplies.
- Keep the current loop from each of the outputs through the output inductor and the small filter capacitor and back to GND as small and tight as possible. The size of this current loop determines its effectiveness as an antenna.
- Grounding: TI recommends a big common GND plane. The PVDD decoupling capacitors should connect to GND. The TAS5727 PowerPAD should be connected to GND.
- Output filter: remember to select inductors that can handle the high short-circuit current of the device. The LC filter should be placed close to the outputs.

The [EVM product folder](#) and User's Guide available on www.ti.com shows schematic, bill of material, gerber files, and more detailed layout plots.

13.2 Layout Example

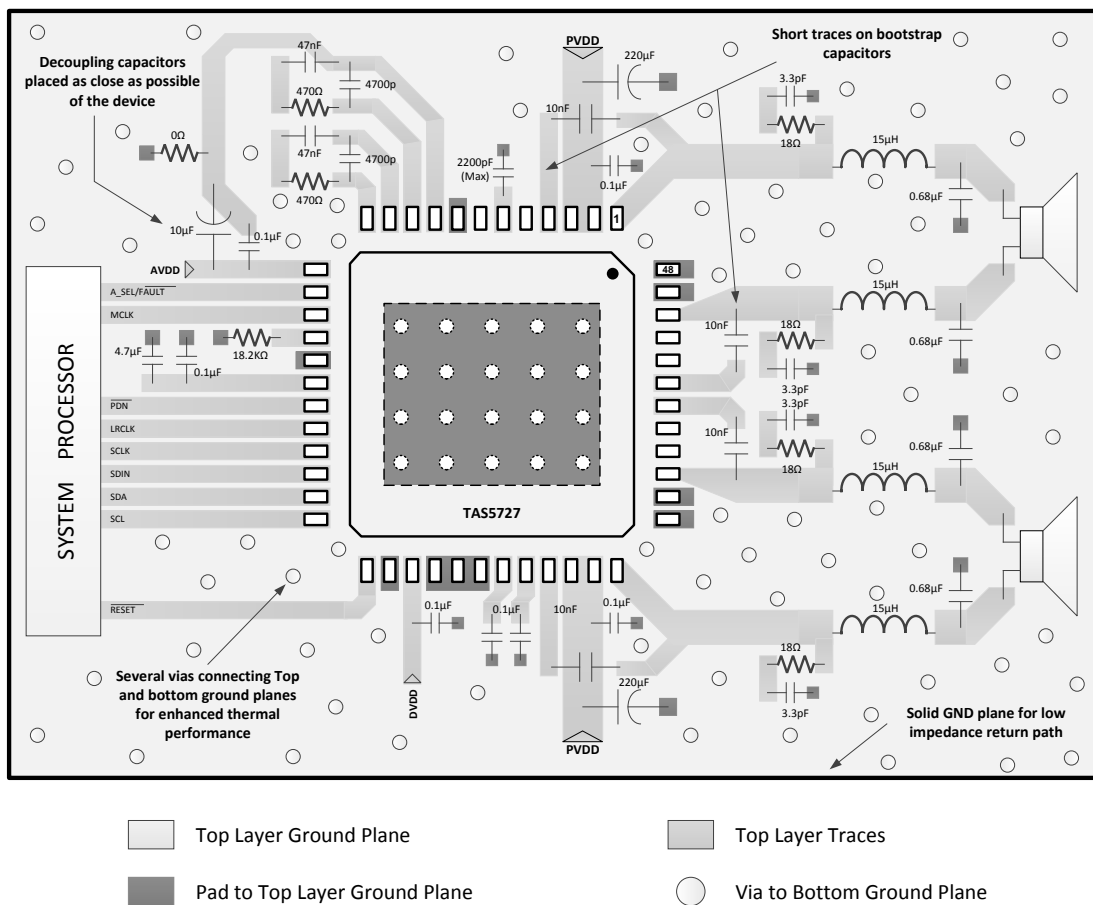

Figure 46. Layout Example

14 Device and Documentation Support

14.1 Device Support

14.1.1 Development Support

For development support, see the following:

[TAS57xx GDE](#)

14.2 Documentation Support

14.2.1 Related Documentation

For related documentation, see the following:

- *TAS5727 25-W Digital Input Amplifier With EQ and 2-Band DRC*, [SLOU299](#)
- *TAS5721-TAS5723EVM User's Guide*, [SLOU346](#)
- *Class-D LC Filter Design*, [SLOA119](#)

14.3 Receiving Notification of Documentation Updates

To receive notification of documentation updates, navigate to the device product folder on ti.com. In the upper right corner, click on *Alert me* to register and receive a weekly digest of any product information that has changed. For change details, review the revision history included in any revised document.

14.4 Community Resources

The following links connect to TI community resources. Linked contents are provided "AS IS" by the respective contributors. They do not constitute TI specifications and do not necessarily reflect TI's views; see TI's [Terms of Use](#).

TI E2E™ Online Community *TI's Engineer-to-Engineer (E2E) Community*. Created to foster collaboration among engineers. At e2e.ti.com, you can ask questions, share knowledge, explore ideas and help solve problems with fellow engineers.

Design Support *TI's Design Support* Quickly find helpful E2E forums along with design support tools and contact information for technical support.

14.5 Trademarks

PowerPAD, E2E are trademarks of Texas Instruments.
All other trademarks are the property of their respective owners.

14.6 Electrostatic Discharge Caution



This integrated circuit can be damaged by ESD. Texas Instruments recommends that all integrated circuits be handled with appropriate precautions. Failure to observe proper handling and installation procedures can cause damage.

ESD damage can range from subtle performance degradation to complete device failure. Precision integrated circuits may be more susceptible to damage because very small parametric changes could cause the device not to meet its published specifications.

14.7 Glossary

[SLYZ022](#) — *TI Glossary*.

This glossary lists and explains terms, acronyms, and definitions.

15 Mechanical, Packaging, and Orderable Information

The following pages include mechanical, packaging, and orderable information. This information is the most current data available for the designated devices. This data is subject to change without notice and revision of this document. For browser-based versions of this data sheet, refer to the left-hand navigation.

PACKAGING INFORMATION

Orderable Device	Status (1)	Package Type	Package Drawing	Pins	Package Qty	Eco Plan (2)	Lead finish/ Ball material (6)	MSL Peak Temp (3)	Op Temp (°C)	Device Marking (4/5)	Samples
TAS5727PHP	ACTIVE	HTQFP	PHP	48	250	RoHS & Green	NIPDAU	Level-3-260C-168 HR	0 to 85	TAS5727	Samples
TAS5727PHPR	ACTIVE	HTQFP	PHP	48	1000	RoHS & Green	NIPDAU	Level-3-260C-168 HR	0 to 85	TAS5727	Samples

(1) The marketing status values are defined as follows:

ACTIVE: Product device recommended for new designs.

LIFEBUY: TI has announced that the device will be discontinued, and a lifetime-buy period is in effect.

NRND: Not recommended for new designs. Device is in production to support existing customers, but TI does not recommend using this part in a new design.

PREVIEW: Device has been announced but is not in production. Samples may or may not be available.

OBSOLETE: TI has discontinued the production of the device.

(2) **RoHS:** TI defines "RoHS" to mean semiconductor products that are compliant with the current EU RoHS requirements for all 10 RoHS substances, including the requirement that RoHS substance do not exceed 0.1% by weight in homogeneous materials. Where designed to be soldered at high temperatures, "RoHS" products are suitable for use in specified lead-free processes. TI may reference these types of products as "Pb-Free".

RoHS Exempt: TI defines "RoHS Exempt" to mean products that contain lead but are compliant with EU RoHS pursuant to a specific EU RoHS exemption.

Green: TI defines "Green" to mean the content of Chlorine (Cl) and Bromine (Br) based flame retardants meet JS709B low halogen requirements of <=1000ppm threshold. Antimony trioxide based flame retardants must also meet the <=1000ppm threshold requirement.

(3) MSL, Peak Temp. - The Moisture Sensitivity Level rating according to the JEDEC industry standard classifications, and peak solder temperature.

(4) There may be additional marking, which relates to the logo, the lot trace code information, or the environmental category on the device.

(5) Multiple Device Markings will be inside parentheses. Only one Device Marking contained in parentheses and separated by a "~" will appear on a device. If a line is indented then it is a continuation of the previous line and the two combined represent the entire Device Marking for that device.

(6) Lead finish/Ball material - Orderable Devices may have multiple material finish options. Finish options are separated by a vertical ruled line. Lead finish/Ball material values may wrap to two lines if the finish value exceeds the maximum column width.

Important Information and Disclaimer:The information provided on this page represents TI's knowledge and belief as of the date that it is provided. TI bases its knowledge and belief on information provided by third parties, and makes no representation or warranty as to the accuracy of such information. Efforts are underway to better integrate information from third parties. TI has taken and continues to take reasonable steps to provide representative and accurate information but may not have conducted destructive testing or chemical analysis on incoming materials and chemicals. TI and TI suppliers consider certain information to be proprietary, and thus CAS numbers and other limited information may not be available for release.

In no event shall TI's liability arising out of such information exceed the total purchase price of the TI part(s) at issue in this document sold by TI to Customer on an annual basis.

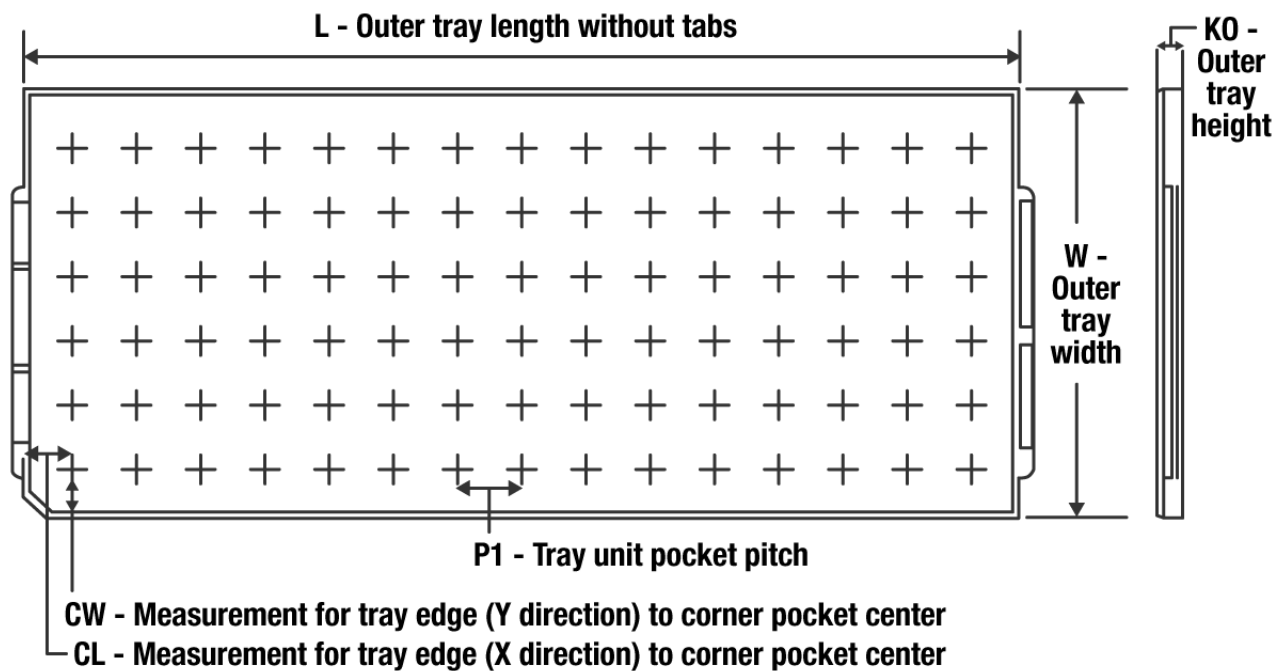
TRAY

Chamfer on Tray corner indicates Pin 1 orientation of packed units.

*All dimensions are nominal

Device	Package Name	Package Type	Pins	SPQ	Unit array matrix	Max temperature (°C)	L (mm)	W (mm)	K0 (µm)	P1 (mm)	CL (mm)	CW (mm)
TAS5727PHP	PHP	HTQFP	48	250	10 x 25	150	315	135.9	7620	12.2	11.1	11.25

GENERIC PACKAGE VIEW

PHP 48

TQFP - 1.2 mm max height

7 x 7, 0.5 mm pitch

QUAD FLATPACK

This image is a representation of the package family, actual package may vary.
Refer to the product data sheet for package details.



4226443/A

PHP (S-PQFP-G48)

PowerPAD™ PLASTIC QUAD FLATPACK

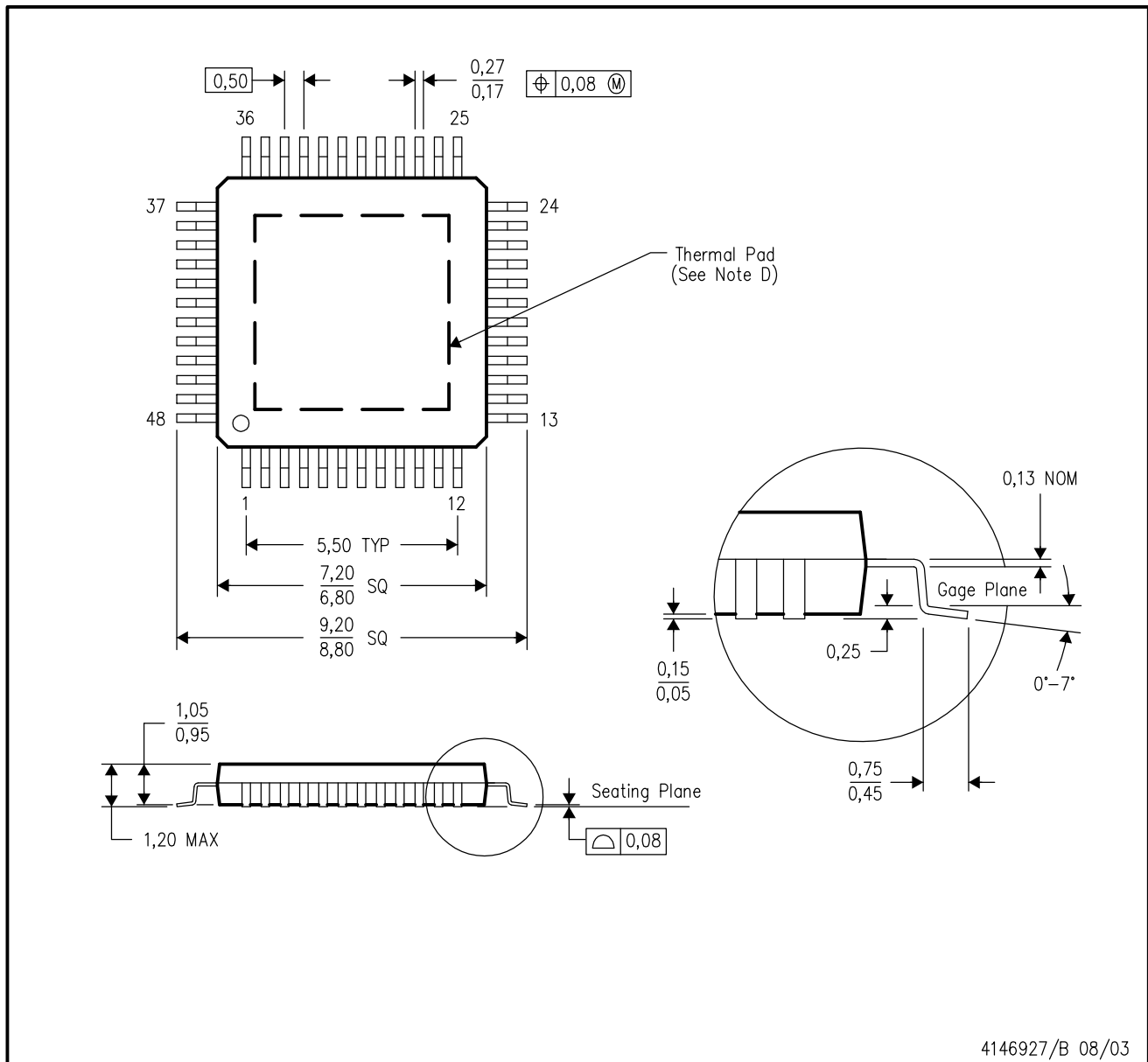

- NOTES:
- A. All linear dimensions are in millimeters.
 - B. This drawing is subject to change without notice.
 - C. Body dimensions do not include mold flash or protrusion
 - D. This package is designed to be soldered to a thermal pad on the board. Refer to Technical Brief, PowerPad Thermally Enhanced Package, Texas Instruments Literature No. SLMA002 for information regarding recommended board layout. This document is available at www.ti.com <<http://www.ti.com>>.
 - E. Falls within JEDEC MS-026

PowerPAD is a trademark of Texas Instruments.

THERMAL PAD MECHANICAL DATA

PHP (S-PQFP-G48)

PowerPAD™ PLASTIC QUAD FLATPACK

THERMAL INFORMATION

This PowerPAD™ package incorporates an exposed thermal pad that is designed to be attached to a printed circuit board (PCB). The thermal pad must be soldered directly to the PCB. After soldering, the PCB can be used as a heatsink. In addition, through the use of thermal vias, the thermal pad can be attached directly to the appropriate copper plane shown in the electrical schematic for the device, or alternatively, can be attached to a special heatsink structure designed into the PCB. This design optimizes the heat transfer from the integrated circuit (IC).

For additional information on the PowerPAD package and how to take advantage of its heat dissipating abilities, refer to Technical Brief, PowerPAD Thermally Enhanced Package, Texas Instruments Literature No. SLMA002 and Application Brief, PowerPAD Made Easy, Texas Instruments Literature No. SLMA004. Both documents are available at www.ti.com.

The exposed thermal pad dimensions for this package are shown in the following illustration.

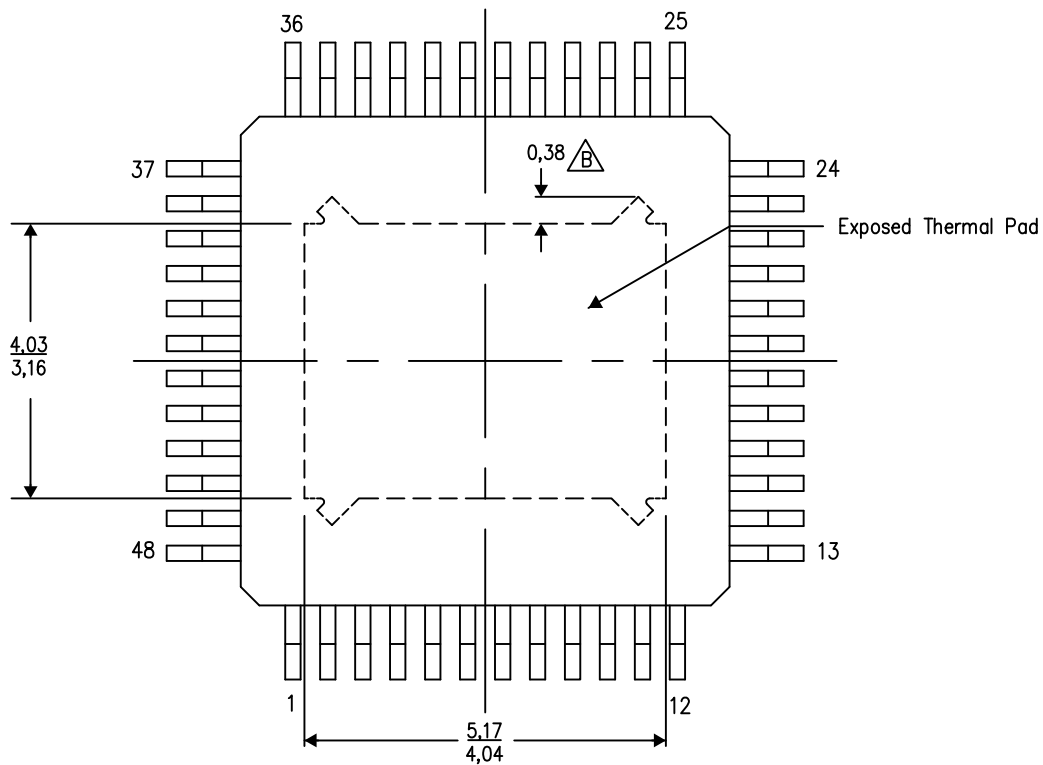

Exposed Thermal Pad Dimensions

4206329-18/P 03/15

NOTE: A. All linear dimensions are in millimeters

 Tie strap features may not be present.

PowerPAD is a trademark of Texas Instruments

PHP (S-PQFP-G48)

PowerPAD™ PLASTIC QUAD FLATPACK



- NOTES:
- All linear dimensions are in millimeters.
 - This drawing is subject to change without notice.
 - Body dimensions do not include mold flash or protrusion.
 - This package is designed to be soldered to a thermal pad on the board. Refer to Technical Brief, PowerPad Thermally Enhanced Package, Texas Instruments Literature No. SLMA002 for information regarding recommended board layout. This document is available at www.ti.com <<http://www.ti.com>>.
 - Falls within JEDEC MS-026

PowerPAD is a trademark of Texas Instruments.

THERMAL PAD MECHANICAL DATA

PHP (S-PQFP-G48)

PowerPAD™ PLASTIC QUAD FLATPACK

THERMAL INFORMATION

This PowerPAD™ package incorporates an exposed thermal pad that is designed to be attached to a printed circuit board (PCB). The thermal pad must be soldered directly to the PCB. After soldering, the PCB can be used as a heatsink. In addition, through the use of thermal vias, the thermal pad can be attached directly to the appropriate copper plane shown in the electrical schematic for the device, or alternatively, can be attached to a special heatsink structure designed into the PCB. This design optimizes the heat transfer from the integrated circuit (IC).

For additional information on the PowerPAD package and how to take advantage of its heat dissipating abilities, refer to Technical Brief, PowerPAD Thermally Enhanced Package, Texas Instruments Literature No. SLMA002 and Application Brief, PowerPAD Made Easy, Texas Instruments Literature No. SLMA004. Both documents are available at www.ti.com.

The exposed thermal pad dimensions for this package are shown in the following illustration.

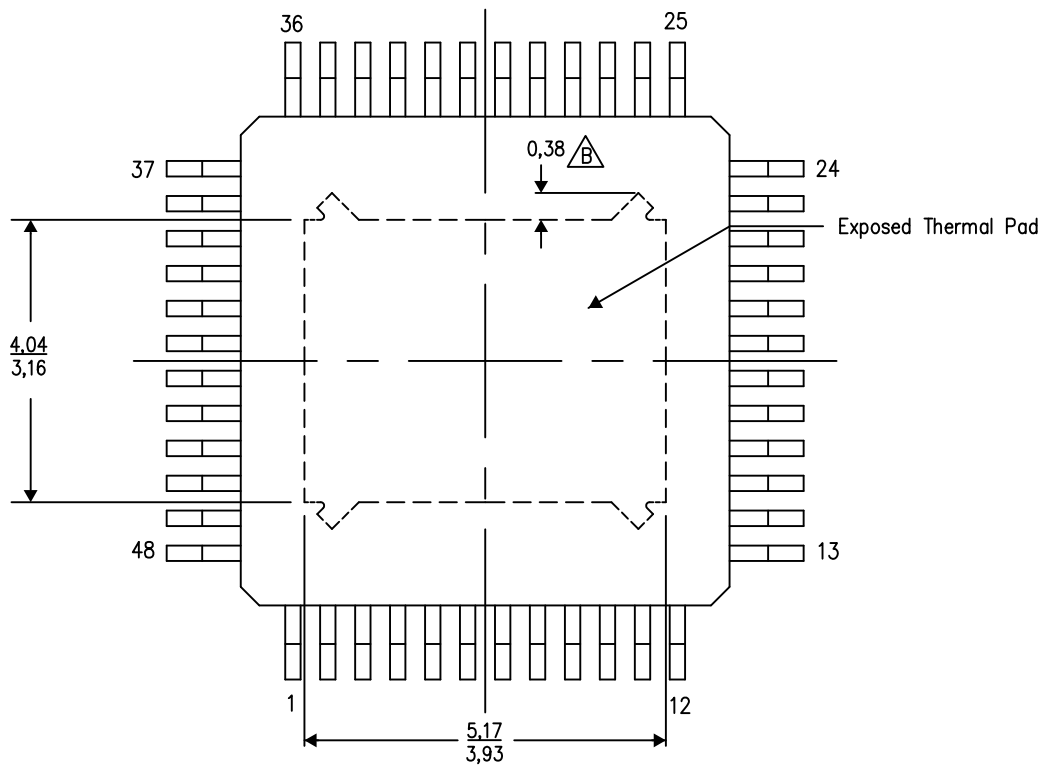

Top View

Exposed Thermal Pad Dimensions

4206329-9/P 03/15

NOTE: A. All linear dimensions are in millimeters

 Tie strap features may not be present.

PowerPAD is a trademark of Texas Instruments

PHP (S-PQFP-G48)

PowerPAD™ PLASTIC QUAD FLATPACK

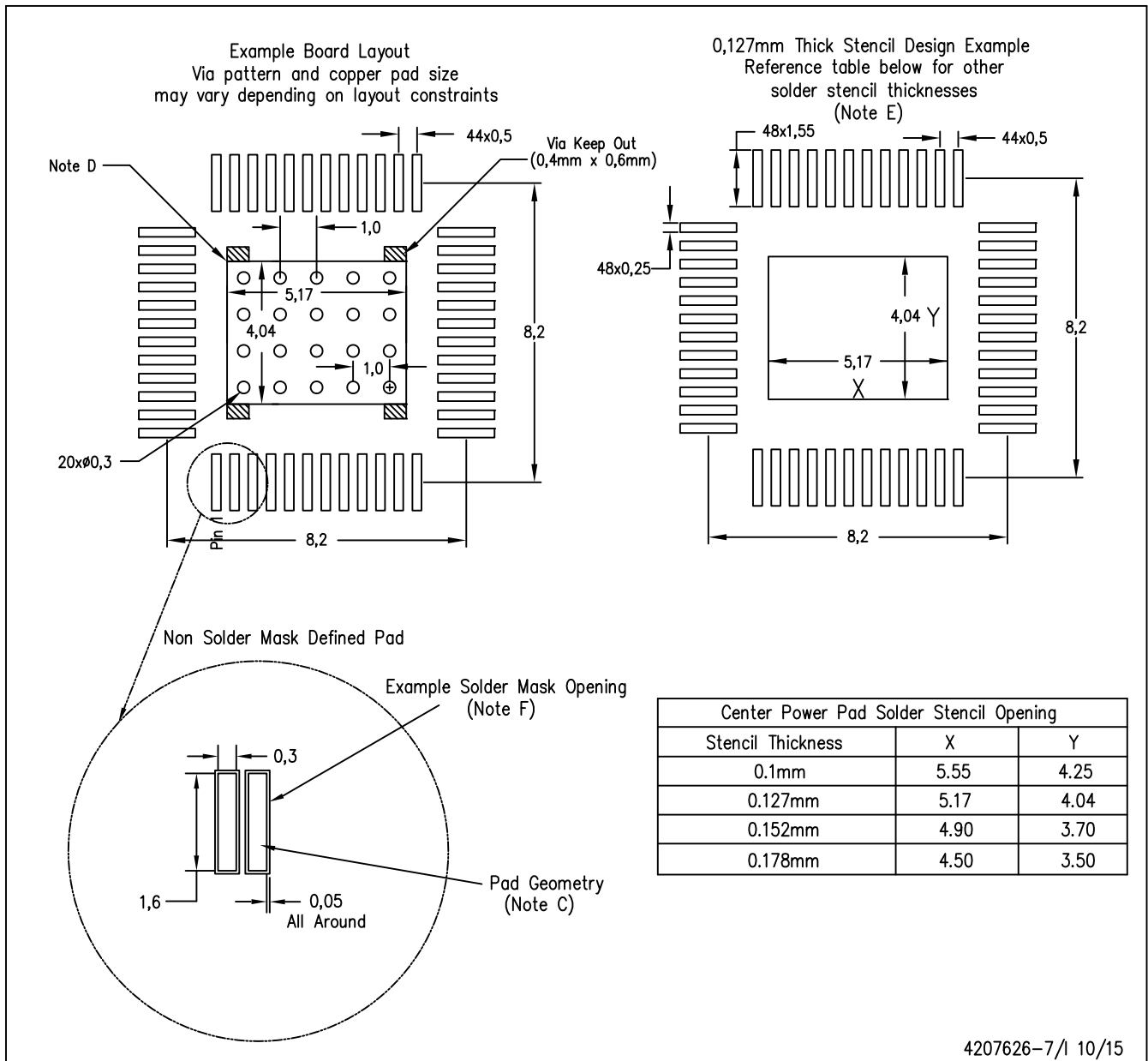

4207626-7/1 10/15

- NOTES:
- A. All linear dimensions are in millimeters.
 - B. This drawing is subject to change without notice.
 - C. Publication IPC-7351 is recommended for alternate designs.
 - D. This package is designed to be soldered to a thermal pad on the board. Refer to Technical Brief, PowerPAD Thermally Enhanced Package, Texas Instruments Literature No. SLMA002, SLMA004, and also the Product Data Sheets for specific thermal information, via requirements, and recommended board layout. These documents are available at www.ti.com <<http://www.ti.com>>.
 - E. Laser cutting apertures with trapezoidal walls and also rounding corners will offer better paste release. Customers should contact their board assembly site for stencil design recommendations. Refer to IPC 7525 for stencil design considerations.
 - F. Customers should contact their board fabrication site for recommended solder mask tolerances and via tenting options for vias placed in the thermal pad.

PowerPAD is a trademark of Texas Instruments

IMPORTANT NOTICE AND DISCLAIMER

TI PROVIDES TECHNICAL AND RELIABILITY DATA (INCLUDING DATA SHEETS), DESIGN RESOURCES (INCLUDING REFERENCE DESIGNS), APPLICATION OR OTHER DESIGN ADVICE, WEB TOOLS, SAFETY INFORMATION, AND OTHER RESOURCES "AS IS" AND WITH ALL FAULTS, AND DISCLAIMS ALL WARRANTIES, EXPRESS AND IMPLIED, INCLUDING WITHOUT LIMITATION ANY IMPLIED WARRANTIES OF MERCHANTABILITY, FITNESS FOR A PARTICULAR PURPOSE OR NON-INFRINGEMENT OF THIRD PARTY INTELLECTUAL PROPERTY RIGHTS.

These resources are intended for skilled developers designing with TI products. You are solely responsible for (1) selecting the appropriate TI products for your application, (2) designing, validating and testing your application, and (3) ensuring your application meets applicable standards, and any other safety, security, regulatory or other requirements.

These resources are subject to change without notice. TI grants you permission to use these resources only for development of an application that uses the TI products described in the resource. Other reproduction and display of these resources is prohibited. No license is granted to any other TI intellectual property right or to any third party intellectual property right. TI disclaims responsibility for, and you will fully indemnify TI and its representatives against, any claims, damages, costs, losses, and liabilities arising out of your use of these resources.

TI's products are provided subject to [TI's Terms of Sale](#) or other applicable terms available either on ti.com or provided in conjunction with such TI products. TI's provision of these resources does not expand or otherwise alter TI's applicable warranties or warranty disclaimers for TI products.

TI objects to and rejects any additional or different terms you may have proposed.

Mailing Address: Texas Instruments, Post Office Box 655303, Dallas, Texas 75265
Copyright © 2022, Texas Instruments Incorporated