

## InstaSPIN™ BLDC Lab

---

### 1 Introduction

For this lab we are using the Three Phase BLDC Motor Kit with DRV8312 and Piccolo™ MCU ([DRV8312-C2-KIT](#)) (the [DRV8302-HC-C2-KIT](#) or [DRV8301-HC-C2-KIT](#) can also be used) with a Piccolo F28035 controlCARD™ subsystem to run the sensorless [InstaSPIN™ BLDC technique](#). These are the tasks that must be done to spin motors:

1. Make sure all physical connections and jumper settings on the kit are correct.
2. Flash the InstaSPIN BLDC object file (.out) onto the controlCARD
3. Launch the GUI
4. Start spinning motors

### 2 Using the InstaSPIN™ BLDC Solution

#### 2.1 DRV8312 Setup

Jumpers and switches must be set up properly, or the kit does not function correctly.

1. Three position toggle switches **RSTA**, **RSTB**, and **RSTC** must be in the **center/middle** position.
2. Jumper **JP1** must be in the **VR1** position.
3. Jumper **M1** must be in the **H** position.
4. Switch **SW3** on the Control Card must be in the **On** position see [Figure 2](#).
5. Connect the three motor phase wires into **MOA**, **MOB**, and **MOC** of the kit.

**Question:** What do you think will happen if you connect the motor wires in a different order?

- (a) The brushes in the motor will overheat and could cause a fire.
- (b) The current in the wires will reverse the polarity of the anti-protons in the magnetic field, causing an antimatter explosion.
- (c) Nothing will happen except the motor may spin in the opposite direction.
- (d) You could potentially damage the DRV8312, resulting in your immediate termination from TI.
- (e) This is a trick question because the connector is keyed, prohibiting the motor wires from being connected in any other way than what is shown.

The correct answer is given at the end of this document.

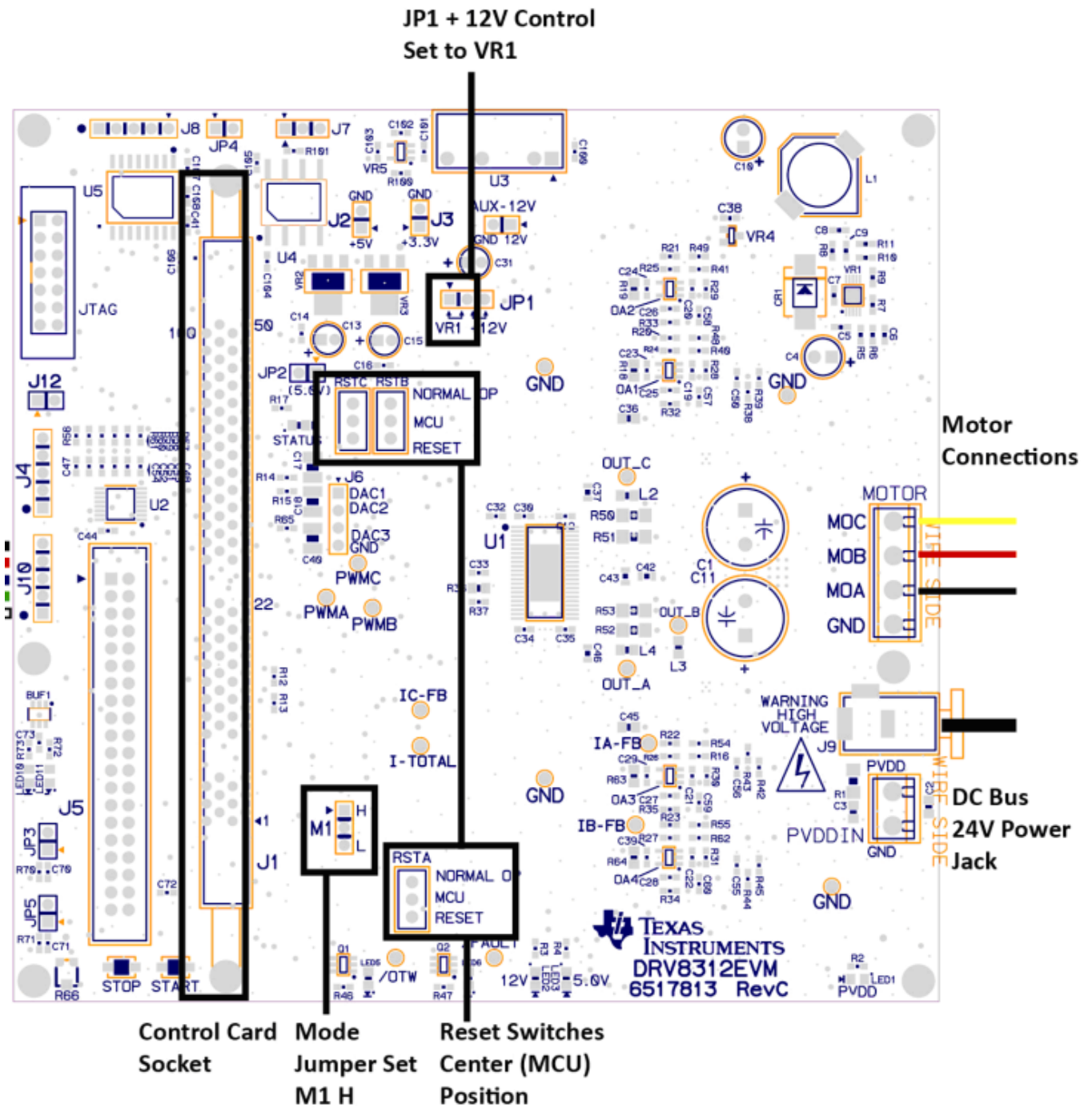

## 2.2 controlCARD™ Setup and Programming

The included controlCARD comes with the switch (SW3) set to hold the XDS100v1 emulator in JTAG reset (switch is up (OFF)) for use with USB-UART GUI communication. To reprogram the Flash using CCS, allow JTAG access by **setting SW3 down (ON)**.

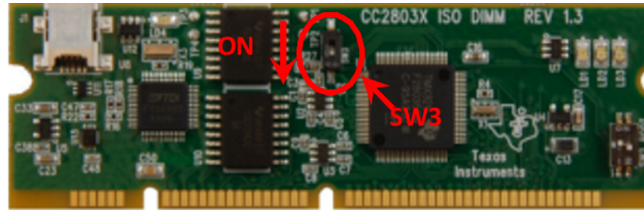

Figure 2. controlCARD Setup

1. Insert controlCARD into DRV8312 baseboard.
2. Plug the 24-V power supply into J9 of the DRV8312 kit.
3. Connect the USB cable from your PC to the controlCARD.
4. Open Code Composer Studio version 4 (CCS).
5. Click Target → New Target Configuration (see Figure 3).

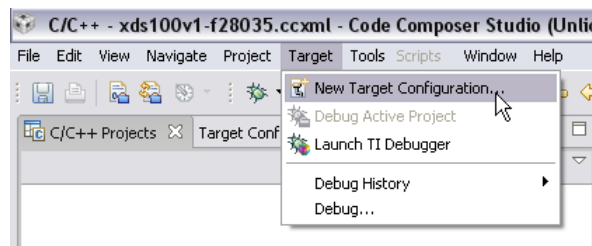

Figure 3. CCS New Target Configuration

6. Name what you like (for example, xds100v1-f28035.ccxml).
7. Connection: Texas Instruments XDS100v1 USB Emulator.
8. Device: TMS320F28035 and click Save (see Figure 4).

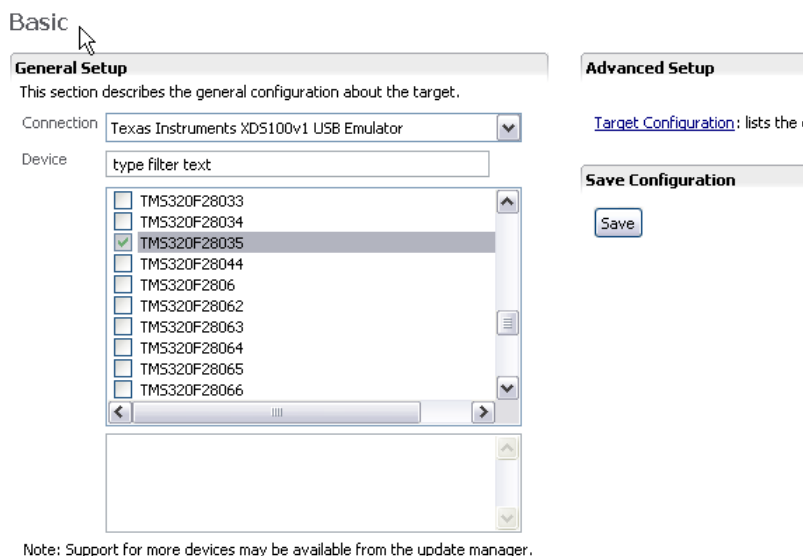
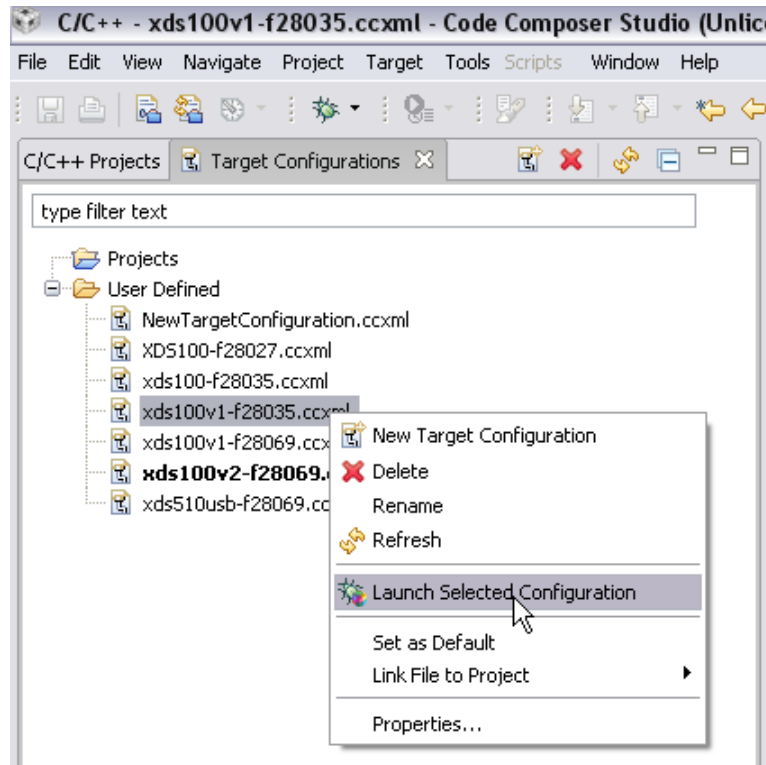

Figure 4. CCS General Setup

- On the Target Configurations Tab, right click on your new Target and click "Launch Selected Configuration" in the context menu (see Figure 5).



**Figure 5. CCS Launch Selected Configuration**

- Click "Target -> Connect Target" (see Figure 6).

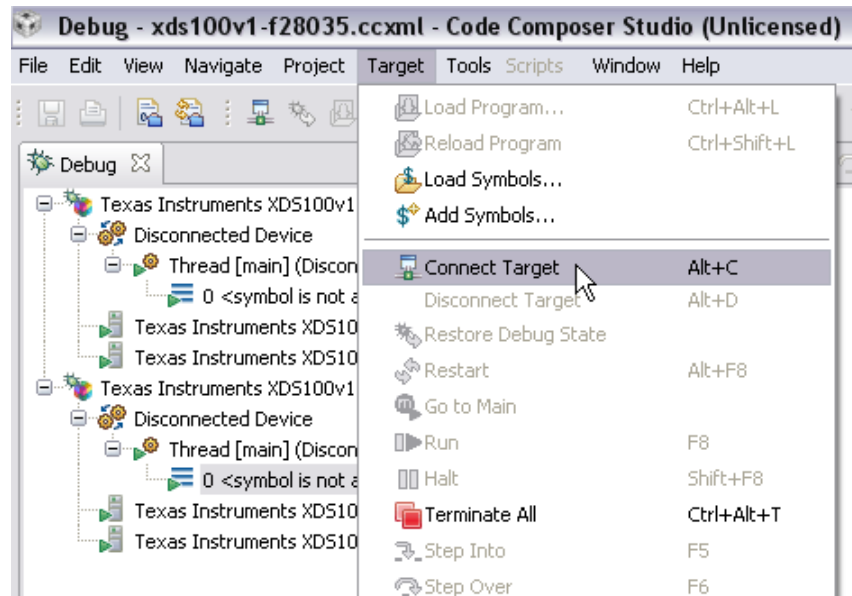

**Figure 6. CCS Connect Target**

- To choose the object file to flash onto the device, click the menu item "Target -> Load Program...".
- Click the "Browse" button and find the file "InstaSPIN BLDC\_GUI\_DRV8312\_v100.out" from USB Stick or C:\ti\controlSUITE\development\_kits\DRV8312-C2-KIT\_v1XX\~GUI.
- Click "Open" and then "OK". The flash is reprogrammed.

- Click "Terminate All" (see [Figure 7](#)) and close CCStudio.

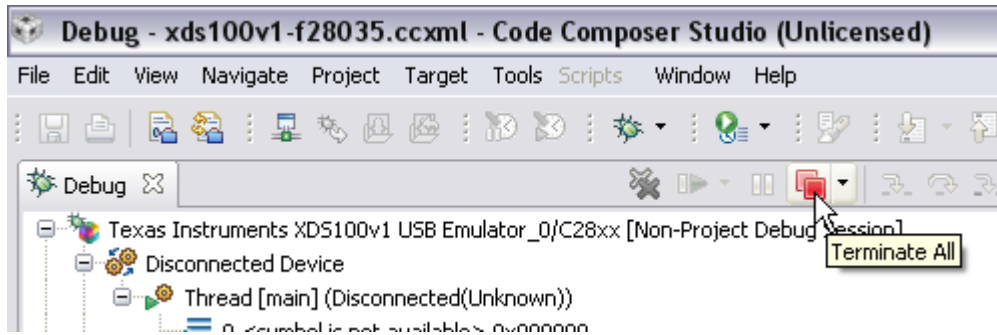

Figure 7. CCS Terminate All

### 2.3 Cycle Power and Run

- Remove 24-V power from the DRV8312 kit.
  - Remove the USB plug from the controlCARD.
  - Plug the 24-V power supply into the DRV8312 kit.
  - Connect the USB cable between the computer and controlCARD.
  - Run InstaSPIN BLDC\_GUI\_DRV83xx\_v100.exe from USB Stick or C:\ti\controlSUITE\development\_kits\DRV8312-C2-KIT\_v1XX\~GUI.
- If you see the message shown in [Figure 8](#), click "Yes".

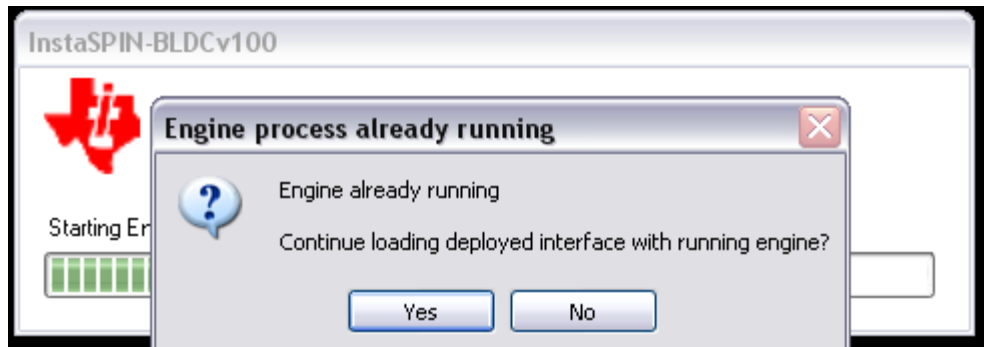

Figure 8. Engine Process Already Running

- The GUI should automatically connect. Verify by viewing "Connected" in the lower left hand corner (see [Figure 9](#)). Also verify that the Fault Status, DC Bus, and Over-temperature Warning lights are green.

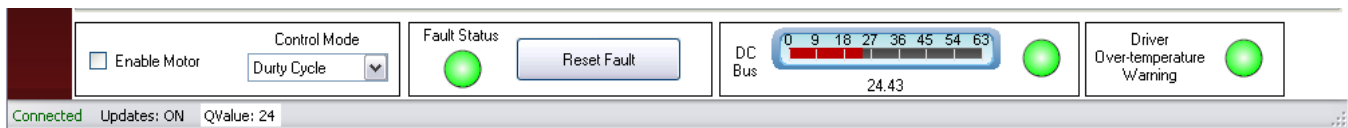

Figure 9. Verify Connection

A full quick start guide for the InstaSPIN BLDC GUI can be found in C:\ti\controlSUITE\development\_kits\DRV8312-C2-KIT\_v1XX\~GUI.

## 2.4 Spinning the Motor

1. On the Main tab, click "Enable Motor" (see Figure 10).

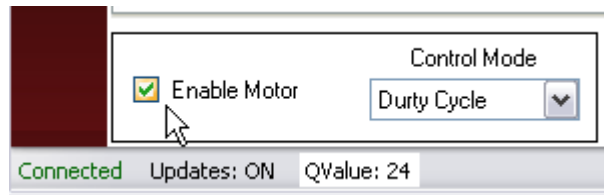

Figure 10. Enable Motor

2. The motor starts to spin with default settings:  
Duty Cycle = 0.3  
PU = 2129 RPM
3. Congratulations! You just did InstaSPIN!

## 2.5 Tuning the Motor Commutation

All motors tune differently, but InstaSPIN BLDC and the GUI allow easier tuning information to be gathered for the motor in question. The following steps are used to tune the motor that comes with the DRV8312 kit.

1. Set duty cycle setting to 0.1.
2. Turn on "Start Continuous Read" on the upper graphs (see Figure 11).

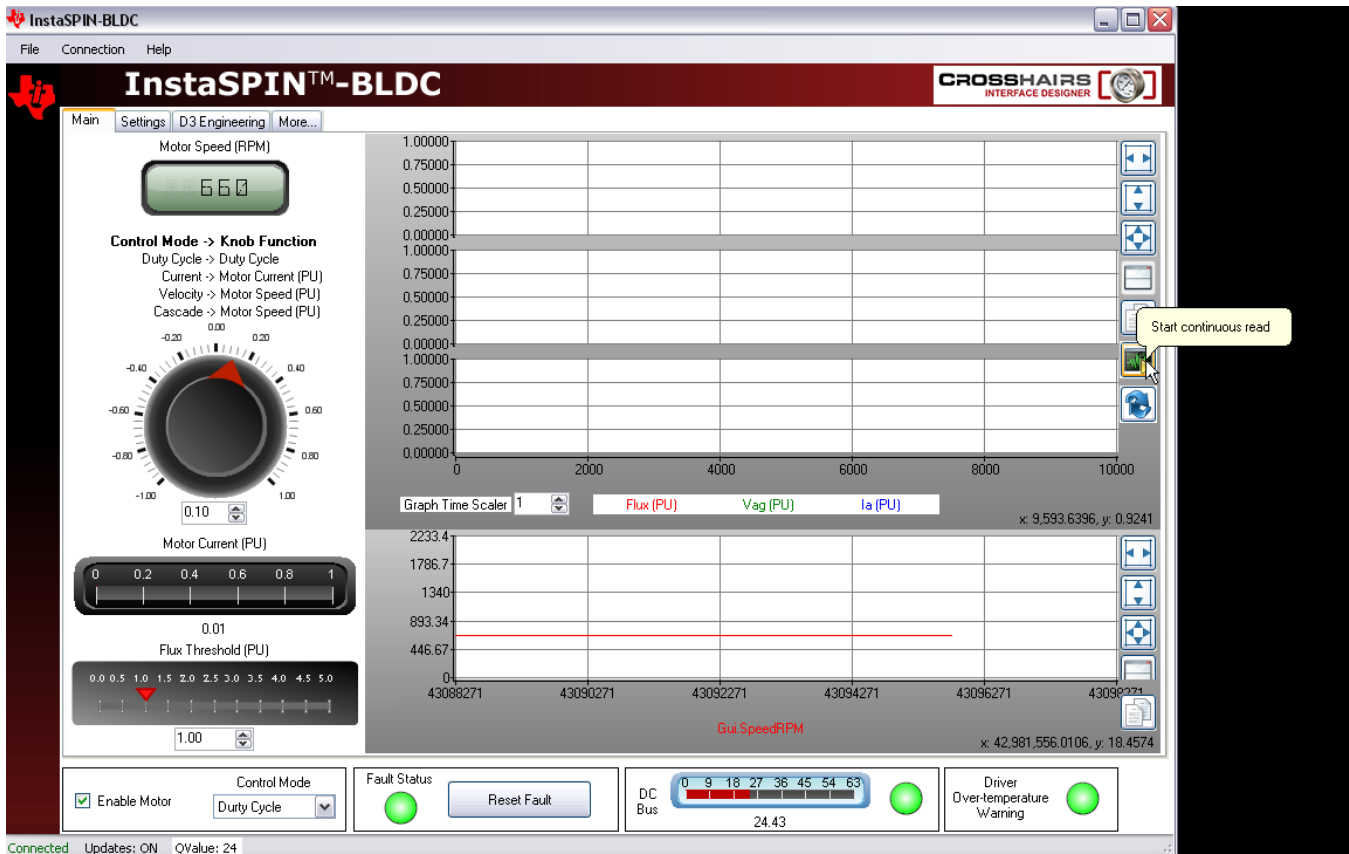

Figure 11. Start Continuous Read

- Adjust Graph Time Scale to 5 (see Figure 12):  
 Top Graph: Displays the per-unit (PU) integrated motor flux.  
 Second Graph: Displays the per-unit (PU) Phase A BEMF waveform.  
 Third Graph: Displays the per-unit (PU) Phase A current waveform.

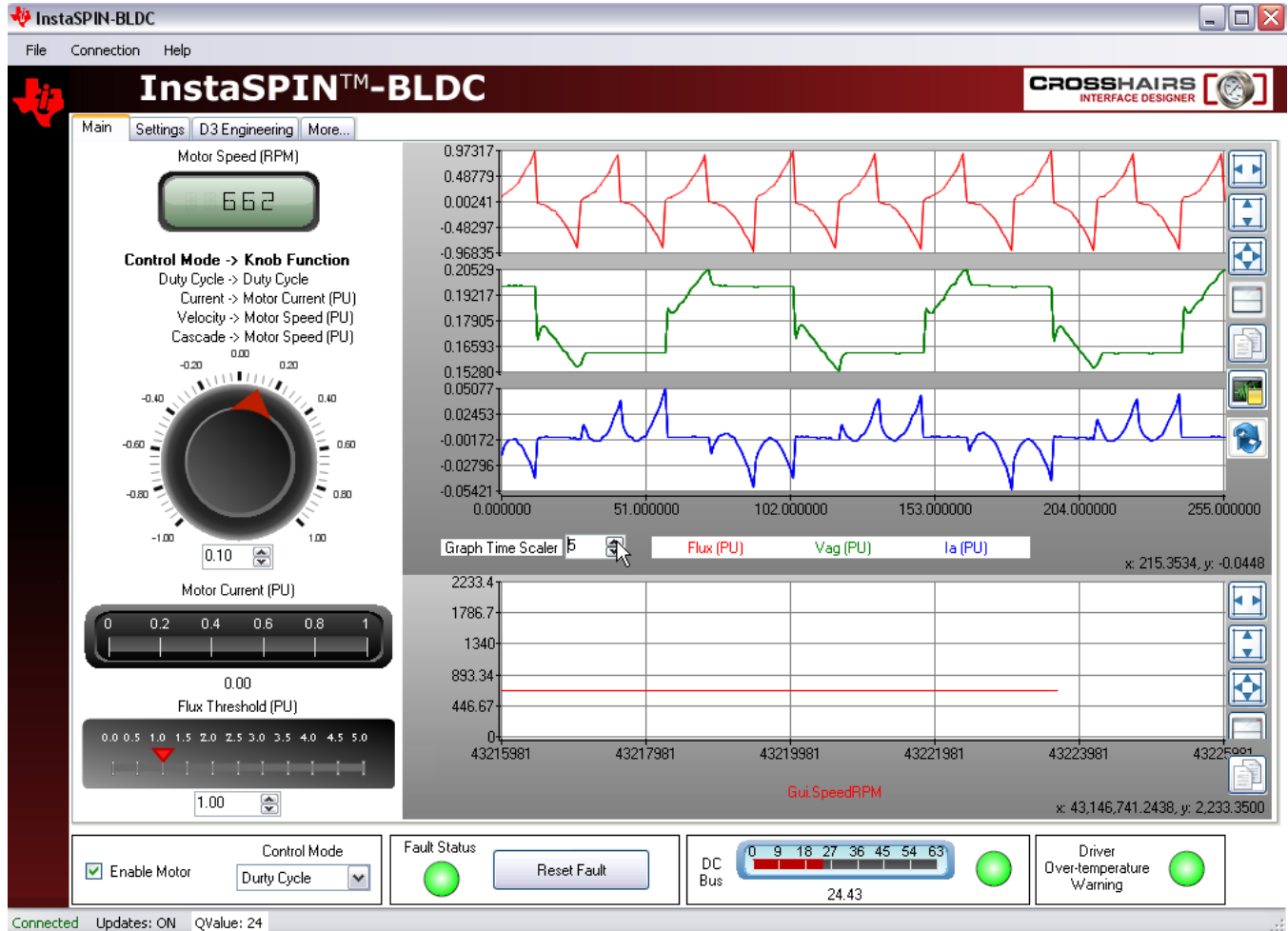

Figure 12. Adjust Graph Time Scale

- Looking at the green voltage signal  $V_{ag}$ , the commutation is happening too late as can be seen by the overshoot where the red arrow is pointing in Figure 13.



Figure 13. Voltage Overshoot

- Adjust the "Flux Threshold" to a smaller value (approximately 0.4) until the commutation happens at the inflection point of the voltage waveform (see Figure 14).

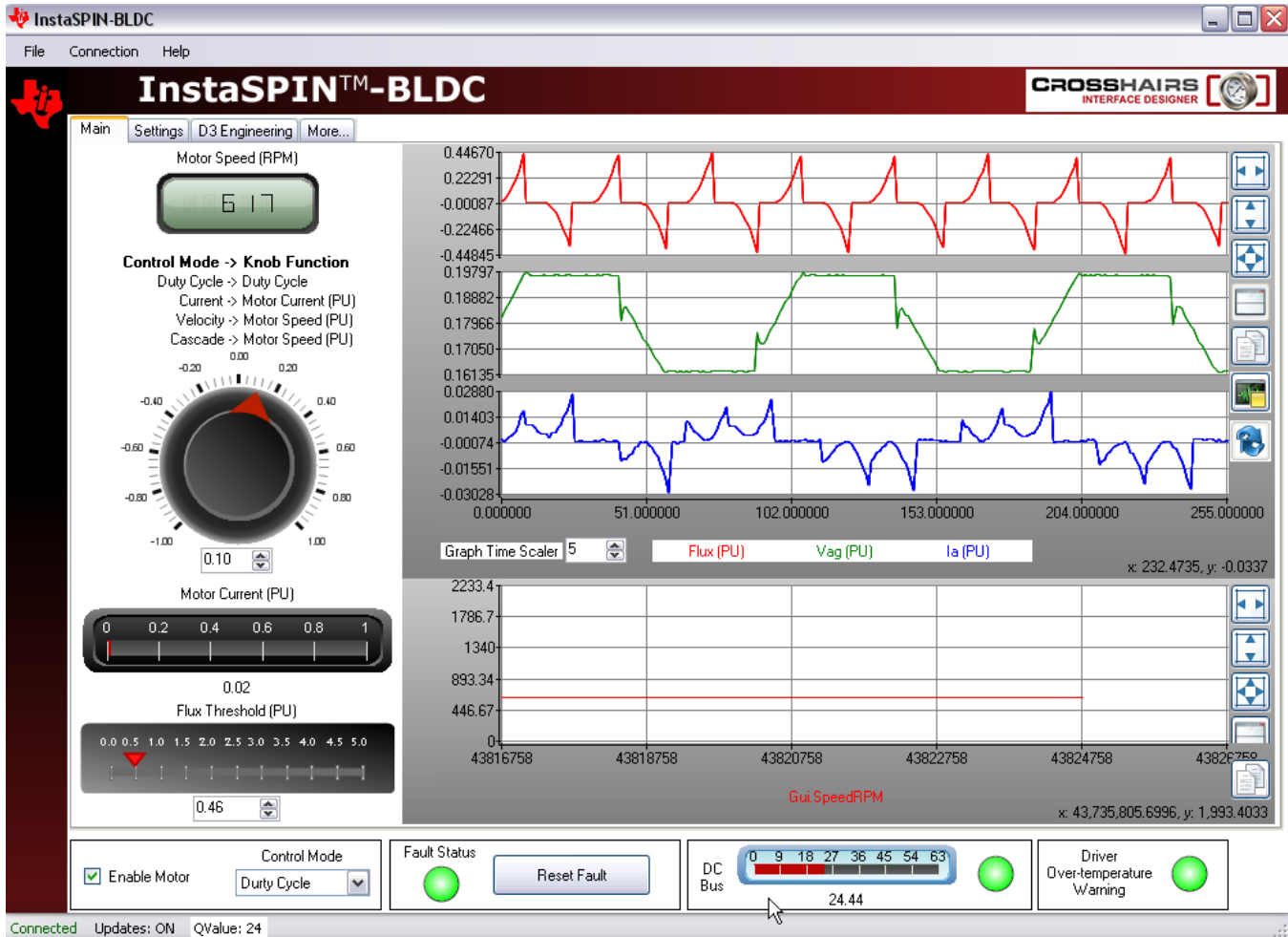

**Figure 14. Adjust Flux Threshold**

The motor is now tuned for the InstaSPIN BLDC technique.

The best way to get a feeling for tuning is to take different types of motors and try to get them to spin properly across the whole duty cycle range by adjusting the Flux Threshold. At lower speeds, most motors run quieter at lower flux threshold values but deliver more torque at higher flux thresholds. At higher speeds, torque response also improves by lowering the flux threshold (can you guess why?) ...It turns out that a BLDC motor works very much like a combustion engine. At higher speeds, you want to advance the spark timing because it takes a finite amount of time to ignite the fuel vapor in the cylinder. If the engine is running at high RPM, by the time the fuel has ignited and the force of the explosion is felt on the piston, the piston has already moved past the optimal point where that force can do the most good. The same is true for a BLDC motor. It takes a finite amount of time to commutate a BLDC motor (get the current extinguished in one coil and built up in another. If the motor is running at high RPM, by the time the commutation takes place, the rotor has already moved past the optimal point where the magnetic force can do the most good. Advancing the commutation timing is just like advancing the spark timing in a combustion engine.



## 2.6 Extra Credit: Cascade Speed Control With InstaSPIN BLDC

With the Control Mode still set to "Duty Cycle", enable the motor and load the motor down with your fingers. What happens to the speed of the motor when you do this? Because there is no control loop regulating the speed, the motor slows down more and more as you increase the load on the shaft. To obtain better speed regulation, enable either "Velocity" mode or "Cascade" mode.

Disable the motor and change the Control Mode to "Cascade" on the "Settings" tab. Leave all other settings at their default values. The panel should then look like Figure 15.

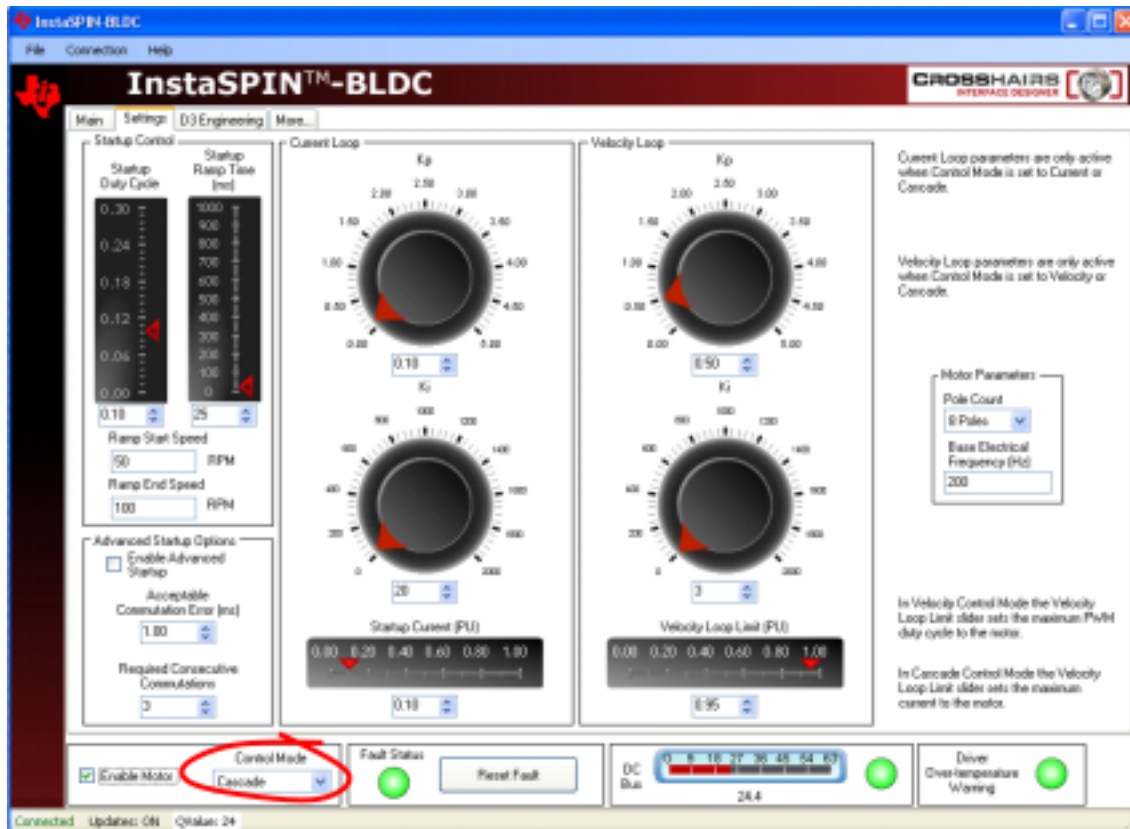

Figure 15. Cascade Control Mode

Switch to the "Main" tab again and verify that the Control knob is set to its default value of 0.3 PU. Enable the motor and verify that it starts up smoothly and ramps to a velocity value of approximately 900 RPM. This can be seen by observing the speed in the Motor Speed RPM window (see Figure 16).



Figure 16. Motor Speed RPM

Now load the motor shaft with your fingers and observe the speed regulation performance of the system. What are your initial impressions? Notice that for constant steady torque loading, the motor eventually

returns to its commanded value of approximately 900 RPM. This is because of the integrators that have been enabled in the control loop. An integrator in a negative feedback control system cannot tolerate any steady state error and will drive it to zero (that is, the commanded value and the controlled value will be equal). However, the response of the system is rather spongy, isn't it? In other words, this is not a "stiff" control system. To stiffen up the response, we must increase the gains of the system.

Disable the motor again and return to the "Settings" tab. Make sure that all of the values on the settings page are set to the values listed below. Values in red are non-default values.

- Startup Duty Cycle: 0.10
- Startup Ramp Time: 1 ms
- Ramp Start Speed: 50 RPM
- Ramp End Speed: 500 RPM
- Kp (current): 0.50
- Ki (current): 20
- Startup Current (PU): 0.10
- Kp (velocity): 1.00
- Ki (velocity): 60
- Velocity Loop Limit (PU): 0.95
- Pole Count: 8 poles
- Base Electrical Frequency (Hz): 200
- Control Mode: Cascade

If set correctly, the Settings page should look like Figure 17.

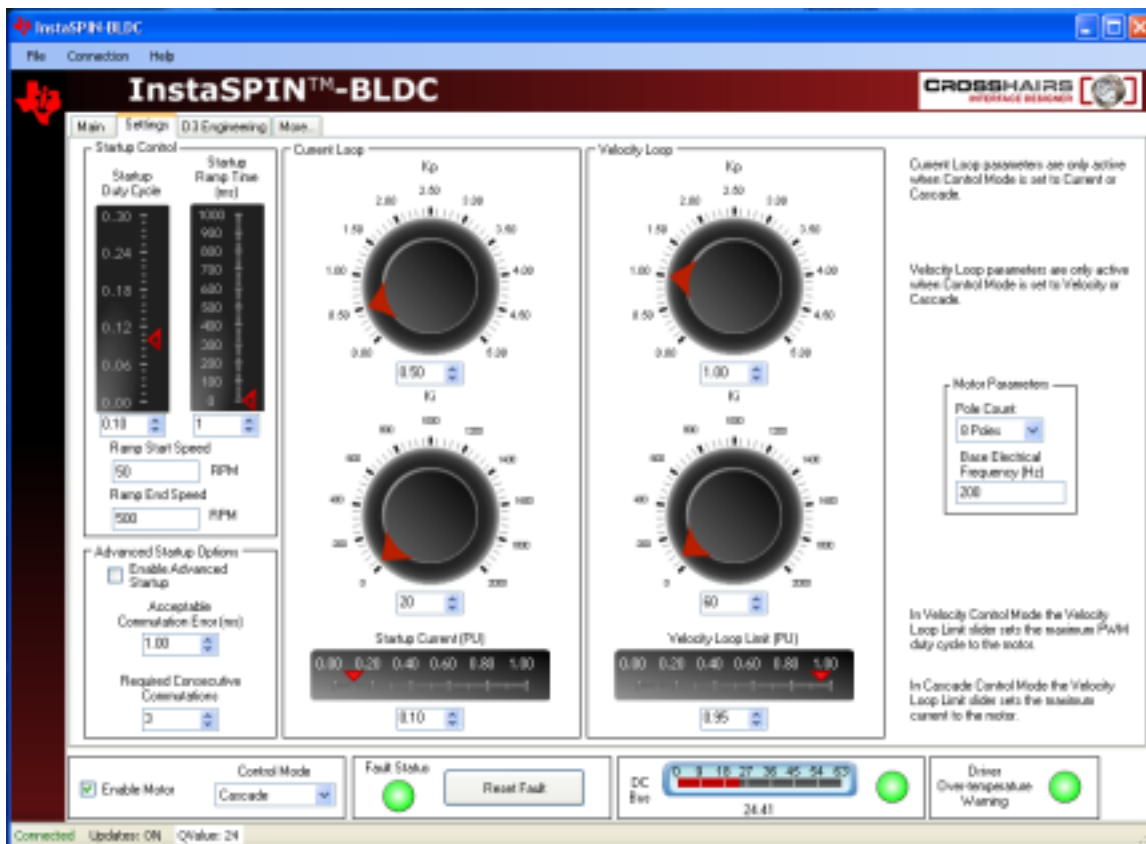

Figure 17. Cascade Control Mode Settings Tab

Assuming you haven't changed the Control knob on the "Main" tab, it should still be set to a PU value of 0.3. If not, change it back to that value now. Once again, enable the motor, and verify that it starts up smoothly and achieves a steady state velocity of approximately 900 RPM.

Again, load the motor shaft with your fingers and observe the speed regulation performance of the system now. What are your initial impressions? Notice that the system is much stiffer in terms of maintaining the commanded speed, irrespective of motor loading.

So if the higher gain settings result in much better tracking performance, then why didn't we specify them as the default values to begin with? To answer this question, let's slowly reduce the speed and see what happens. Using the up-down arrows on the right of the control knob value field, slowly decrement the commanded speed one number at a time. When the value gets close to 19 or so, the system should go unstable.

**QUESTION:** So why would the system be stable at higher speeds, but unstable at lower speeds? (This is a tricky one). Think about it for a moment...

**Hint:** It has something to do with how the velocity feedback signal is synthesized.

**ANSWER:** In order to measure velocity in a sensorless system, the software must measure the duration of each commutation interval. When the motor is spinning at high speed, there are many commutation intervals per second, which means that the velocity feedback value is updated many times per second. However, when the motor is spinning at low speed, the commutation rate is low, which means the update rate for the velocity value is also low. Therefore, the velocity feedback value becomes "stale" when it is not updated for a long period of time. To be more precise, there is a phase lag between the true velocity and the measured velocity when the velocity value is updated so infrequently. This phase lag eats into the phase margin of your system, and when it is all gone, the system goes unstable.

In most sensorless BLDC applications (for example, fans, blowers, and compressors), this is not a problem, because it doesn't make sense to run these loads at ultra-low speeds anyway. But for other applications (for example, washer drum agitation), low speed operation is a requirement, which suggests that a different control scheme is required.

## 2.7 Shutting Down

Uncheck "Enable Motor", close the GUI, and remove power from the DRV8312 board.

### 3 Overview of the GUI Controls

Let's review each of the panels in the GUI interface and explore the functionality of each control.

#### 3.1 Main Tab Overview

Enable Motor Check Box: The Enable Motor check box is used to start or stop the motor

Control Mode drop down box allows the selection of four different control modes:

- Duty Cycle: The motor is commutated using the sensorless algorithm but is driven in an open-loop duty cycle mode.
- Current: The motor is commutated using the sensorless algorithm while the current (torque) is regulated using a PI controller. Note that an unloaded motor rapidly accelerates to a high speed in this mode.
- Velocity: The motor is commutated using the sensorless algorithm while the motor speed is regulated using a PI controller. The output of the speed controller is a PWM duty cycle.
- Cascade: The motor is commutated using the sensorless algorithm while the motor speed is regulated using a PI controller. The output of the speed controller is a motor current command that is regulated by a lower level current PI controller.

The Flux Threshold slider is used to adjust the motor's commutation point.

The Setpoint Knob takes on a separate function for each control mode:

- Duty Cycle: The knob adjusts the PWM duty cycle to the motor.
- Current: The knob adjusts the per-unit (PU) commanded current through the motor.
- Velocity: The knob adjusts the per-unit (PU) motor commanded speed.
- Cascade: The knob adjusts the per-unit (PU) motor commanded speed.

Graphs

- Top Graph: Displays the per-unit (PU) integrated motor flux.
- Second Graph: Displays the per-unit (PU) Phase A BEMF waveform.
- Third Graph: Displays the per-unit (PU) Phase A current waveform.
- Fourth Graph: Displays the motor speed in RPM.

The time scale of the top three graphs can be adjusted by incrementing/decrementing the Graph Time Scalar; the Motor Speed graph is not affected.

### 3.2 Settings Tab Overview

The Settings tab contains parameters affecting motor startup and control loop tuning (see Figure 18).

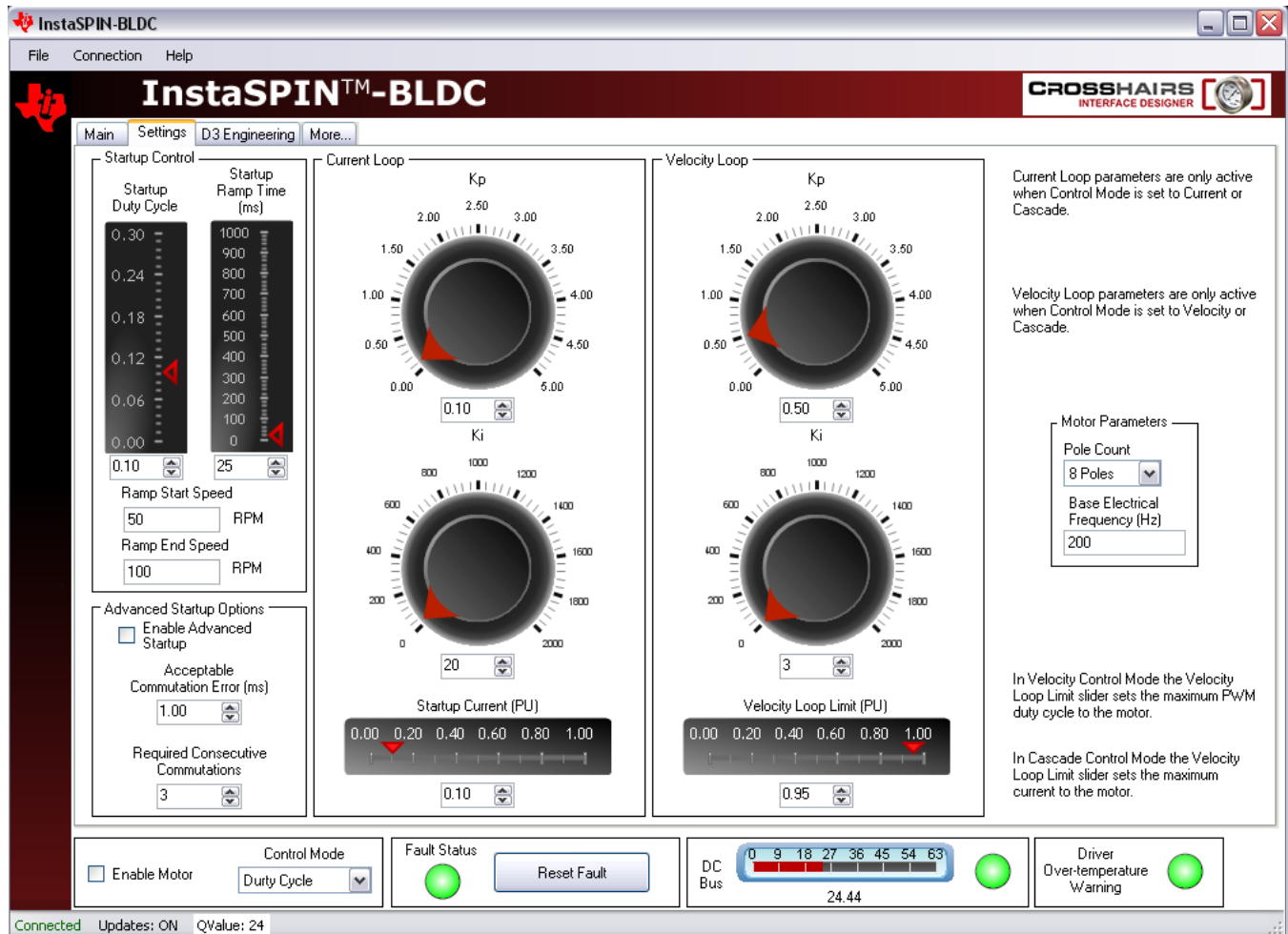

Figure 18. Settings Tab

#### 3.2.1 Startup Control

These parameters control how the motor initially ramps up under forced commutation. It is necessary to get the motor spinning and generating some BEMF for the sensorless algorithm to latch on and take over commutation.

##### Startup Duty Cycle

Sets the constant PWM duty cycle given to the motor during the forced commutation ramp up phase.

##### Startup Ramp Time

Sets the time taken to complete the forced commutation ramp up phase.

##### Ramp Start Speed

Sets the initial speed for the forced commutation ramp up phase.

##### Ramp End Speed

Sets the final speed for the forced commutation ramp up phase.

### 3.2.2 Advanced Startup Options

The controller matches InstaSPIN BLDC detected commutation events to forced commutation events. Once the set number of commutation matches have been met commutation switches to InstaSPIN BLDC.

Enable Advanced Startup

Enable/Disable the Advanced Startup feature.

Acceptable Commutation Error

Allowable error, in ms, between forced commutation events and InstaSPIN BLDC detected commutation events. Commutation events within the error window are considered "good."

Required Consecutive Commutations

Number of required consecutive "good" commutation matches before control switches from forced commutation to InstaSPIN BLDC.

### 3.2.3 Motor Parameters

Pole Count (P)

Input the number of rotor magnet poles for the motor under test.

Base Electrical Frequency (N)

Input the maximum frequency (in cycles per second) of the waveforms to be applied to the motor.

The equation that governs motor speed based on the above parameters is shown in [Equation 1](#).

$$\frac{N \text{ cycles}}{\text{second}} * \frac{60 \text{ seconds}}{\text{minute}} * \frac{2 \text{ revolutions}}{P \text{ cycles}} * (PU) = \frac{N * 60 * 2 * (PU)}{P} \frac{\text{revolutions}}{\text{minute}} \quad (1)$$

Where PU is the Per Unit knob value (0 to 1) for the knob located on the "Main" tab.

The default settings of 200 cycles/second and 8 rotor poles results in a motor speed of 3000 RPM when the knob is set to its maximum value of 1.

### 3.2.4 Current Loop

Contains parameters associated with the current control loop. These parameters are only active when Control Mode is set to Current or Cascade. Those are the only modes that make use of the current loop.

Kp

Sets the proportional gain for the current controller.

Ki

Sets the integral gain for the current controller.

Startup Current

When current control is active the motor is driven with constant current rather than a constant duty cycle during the forced commutation ramp up phase. This slider sets the current for this phase.

### 3.2.5 Velocity Loop

Contains parameters associated with the velocity control loop. These parameters are only active when Control Mode is set to Velocity or Cascade. Those are the only modes that make use of the velocity loop.

---

**NOTE:** The velocity controller may need to be retuned when switching between Velocity and Cascade Control Modes.

---

Kp

Sets the proportional gain for the velocity controller.

Ki

Sets the integral gain for the velocity controller.

Velocity Loop Limit

In Velocity Control Mode the Velocity Loop Limit Slider sets the maximum PWM duty cycle to the motor.

In Cascade Control Mode the Velocity Loop Limit Slider sets the maximum current to the motor.

*The correct answer to the motor wire connection question in [Section 2.1](#) is (c) Nothing will happen except the motor may spin in the opposite direction.*

## IMPORTANT NOTICE

Texas Instruments Incorporated and its subsidiaries (TI) reserve the right to make corrections, modifications, enhancements, improvements, and other changes to its products and services at any time and to discontinue any product or service without notice. Customers should obtain the latest relevant information before placing orders and should verify that such information is current and complete. All products are sold subject to TI's terms and conditions of sale supplied at the time of order acknowledgment.

TI warrants performance of its hardware products to the specifications applicable at the time of sale in accordance with TI's standard warranty. Testing and other quality control techniques are used to the extent TI deems necessary to support this warranty. Except where mandated by government requirements, testing of all parameters of each product is not necessarily performed.

TI assumes no liability for applications assistance or customer product design. Customers are responsible for their products and applications using TI components. To minimize the risks associated with customer products and applications, customers should provide adequate design and operating safeguards.

TI does not warrant or represent that any license, either express or implied, is granted under any TI patent right, copyright, mask work right, or other TI intellectual property right relating to any combination, machine, or process in which TI products or services are used. Information published by TI regarding third-party products or services does not constitute a license from TI to use such products or services or a warranty or endorsement thereof. Use of such information may require a license from a third party under the patents or other intellectual property of the third party, or a license from TI under the patents or other intellectual property of TI.

Reproduction of TI information in TI data books or data sheets is permissible only if reproduction is without alteration and is accompanied by all associated warranties, conditions, limitations, and notices. Reproduction of this information with alteration is an unfair and deceptive business practice. TI is not responsible or liable for such altered documentation. Information of third parties may be subject to additional restrictions.

Resale of TI products or services with statements different from or beyond the parameters stated by TI for that product or service voids all express and any implied warranties for the associated TI product or service and is an unfair and deceptive business practice. TI is not responsible or liable for any such statements.

TI products are not authorized for use in safety-critical applications (such as life support) where a failure of the TI product would reasonably be expected to cause severe personal injury or death, unless officers of the parties have executed an agreement specifically governing such use. Buyers represent that they have all necessary expertise in the safety and regulatory ramifications of their applications, and acknowledge and agree that they are solely responsible for all legal, regulatory and safety-related requirements concerning their products and any use of TI products in such safety-critical applications, notwithstanding any applications-related information or support that may be provided by TI. Further, Buyers must fully indemnify TI and its representatives against any damages arising out of the use of TI products in such safety-critical applications.

TI products are neither designed nor intended for use in military/aerospace applications or environments unless the TI products are specifically designated by TI as military-grade or "enhanced plastic." Only products designated by TI as military-grade meet military specifications. Buyers acknowledge and agree that any such use of TI products which TI has not designated as military-grade is solely at the Buyer's risk, and that they are solely responsible for compliance with all legal and regulatory requirements in connection with such use.

TI products are neither designed nor intended for use in automotive applications or environments unless the specific TI products are designated by TI as compliant with ISO/TS 16949 requirements. Buyers acknowledge and agree that, if they use any non-designated products in automotive applications, TI will not be responsible for any failure to meet such requirements.

Following are URLs where you can obtain information on other Texas Instruments products and application solutions:

### Products

Audio	<a href="http://www.ti.com/audio">www.ti.com/audio</a>
Amplifiers	<a href="http://amplifier.ti.com">amplifier.ti.com</a>
Data Converters	<a href="http://dataconverter.ti.com">dataconverter.ti.com</a>
DLP® Products	<a href="http://www.dlp.com">www.dlp.com</a>
DSP	<a href="http://dsp.ti.com">dsp.ti.com</a>
Clocks and Timers	<a href="http://www.ti.com/clocks">www.ti.com/clocks</a>
Interface	<a href="http://interface.ti.com">interface.ti.com</a>
Logic	<a href="http://logic.ti.com">logic.ti.com</a>
Power Mgmt	<a href="http://power.ti.com">power.ti.com</a>
Microcontrollers	<a href="http://microcontroller.ti.com">microcontroller.ti.com</a>
RFID	<a href="http://www.ti-rfid.com">www.ti-rfid.com</a>
OMAP Mobile Processors	<a href="http://www.ti.com/omap">www.ti.com/omap</a>
Wireless Connectivity	<a href="http://www.ti.com/wirelessconnectivity">www.ti.com/wirelessconnectivity</a>

### Applications

Communications and Telecom	<a href="http://www.ti.com/communications">www.ti.com/communications</a>
Computers and Peripherals	<a href="http://www.ti.com/computers">www.ti.com/computers</a>
Consumer Electronics	<a href="http://www.ti.com/consumer-apps">www.ti.com/consumer-apps</a>
Energy and Lighting	<a href="http://www.ti.com/energy">www.ti.com/energy</a>
Industrial	<a href="http://www.ti.com/industrial">www.ti.com/industrial</a>
Medical	<a href="http://www.ti.com/medical">www.ti.com/medical</a>
Security	<a href="http://www.ti.com/security">www.ti.com/security</a>
Space, Avionics and Defense	<a href="http://www.ti.com/space-avionics-defense">www.ti.com/space-avionics-defense</a>
Transportation and Automotive	<a href="http://www.ti.com/automotive">www.ti.com/automotive</a>
Video and Imaging	<a href="http://www.ti.com/video">www.ti.com/video</a>

TI E2E Community Home Page

[e2e.ti.com](http://e2e.ti.com)

Mailing Address: Texas Instruments, Post Office Box 655303, Dallas, Texas 75265  
Copyright © 2011, Texas Instruments Incorporated