

800VA Pure Sine Wave Inverter’s Reference Design

Sanjay Dixit, Ambreesh Tripathi, Vikas Chola, and Ankur Verma

ABSTRACT

This application note describes the design principles and the circuit operation of the 800VA pure Sine Wave Inverter.

The pure Sine Wave inverter has various applications because of its key advantages such as operation with very low harmonic distortion and clean power like utility-supplied electricity, reduction in audible and electrical noise in fans, fluorescent lights and so on, along with faster, quieter and cooler running of Inductive loads like microwaves and motors.

Contents

1	Introduction	2
2	Pure Sine Wave Inverter's Design.....	3
2.1	Building Block	3
2.2	Switching Waveform Details.....	5
2.3	Schematic of the Design	8
2.4	Sections of the Design:	11
2.5	Required Steps While Debugging/Working on the Hardware	17
2.6	Waveforms and Test Results of 800VA Sine Wave Inverter’s Reference Design:	19
3	Comparison of Low-Frequency vs. High-Frequency Inverter	28

List of Figures

1	Types of Inverter Outputs.....	2
2	Block Diagram of 600VA to 3 KVA Residential Pure Sine Wave Inverters	3
3	Inverter Mode Gate Drives	4
4	H Bridge Configuration of MOSFETs	5
5	Modulation of Sine Wave With Higher Frequency PWM Signals	6
6	Waveform Generation in Inverter Mode	6
7	Trilevel PWM Signal During the Inverter Mode for Pure Sine Wave Generation	7
8	Charging Mode PWM Switching Explanation	8
9	Main Board's Schematic	9
10	Microcontroller's Daughter Card	11
11	DC-DC Converter's Design	12
12	Gate Driver and Current Sensing	13
13	ODC and OCC Protection.....	14
14	AC Mains Sensing Through Isolated Amplifier	14
15	Relay Operation	15
16	Output Sense, DC Fan, and Buzzer Operations	15
17	Daughter Card's Schematic.....	17
18	TITLE??	18
19	TITLE?	19
20	Waveforms at the Gates of the MOSFETs in Inverter Mode (High-Side A MOSFETs and Low-Side B MOSFETs are Conducting).	19

21	FIG 17: Waveforms at the Gates of the MOSFETs in Inverter Mode (High-Side B MOSFETs and Low-Side A MOSFETs are Conducting).	20
22	Trilevel Switching Across the High-Side A MOSFETs Source (HSA) and High-Side B MOSFETs Source (HSB).	20
23	Trilevel Switching Across the High-Side A MOSFETs Source (HSA) and High-Side B MOSFETs Source (HSB).	21
24	Inverted Waveform (HOA-LOA and HOB-LOB) at the Gates of MOSFETs.	22
25	Dead Band between Complementary HOB and LOB Pair	23
26	Maximum Duty Cycle of the PWM Switching at No Load (at the Inverter's Output) is 88 Percent.	24
27	Maximum Duty Cycle of the PWM Switching at 400 W (at the Inverter's Output) is Increased to 98 Percent to Maintain Voltage regulation at the Inverter's Output by Sensing the Auxiliary Winding. This Results in Slight clipping of Sinusoidal Waveform at the Output.	25
28	Inverter's Output at No Load With 12-V Battery Input.	26
29	Inverter's Output at 400-W Load With 12-V Battery Input	27
30	Waveform During the Charging Mode. The High-Side FET is Switched Off and Both Lower-Side FETs to Ground in the H Bridge are Switched at the Same Time With the Duty Cycle Proportional to the Battery Charge Current	28
31	Bidirectional Low Frequency Inverter	29
32	Bidirectional High-Frequency Inverter	30

List of Tables

Trademarks

All trademarks are the property of their respective owners.

1 Introduction

Power inverter is a device that converts electrical power from DC form to AC form using electronic circuits. Its typical application is to convert battery voltage into conventional household AC voltage allowing you to use electronic devices when an AC power is not available. There are basically three kinds of Inverter out of which, the first set of inverters made, which are now obsolete, produced a Square Wave signal at the output.

The Modified Square Wave also known as the Modified Sine Wave Inverter produces square waves with some dead spots between positive and negative half-cycles at the output. The cleanest utility supply like power source is provided by Pure Sine Wave inverters. The present Inverter market is going through a shift from traditional Modified Sine Wave Inverter to Pure Sine Wave inverters because of the benefits that these inverters offer.

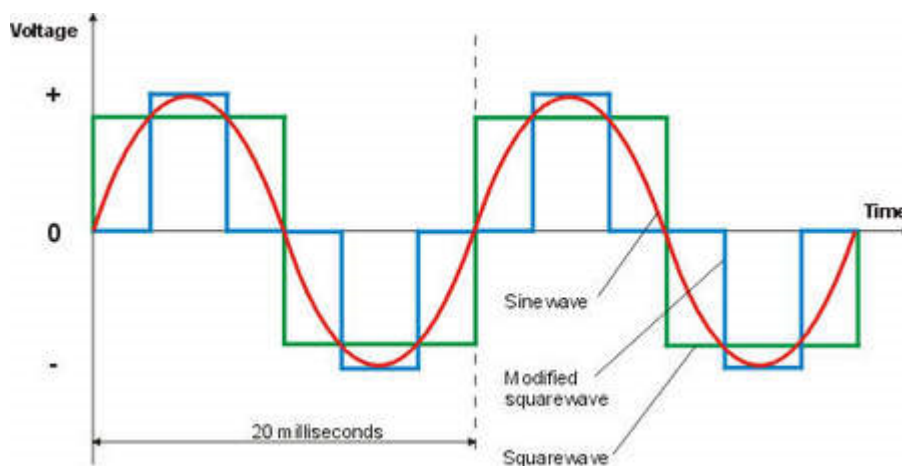

Figure 1. Types of Inverter Outputs

2 Pure Sine Wave Inverter's Design

2.1 Building Block

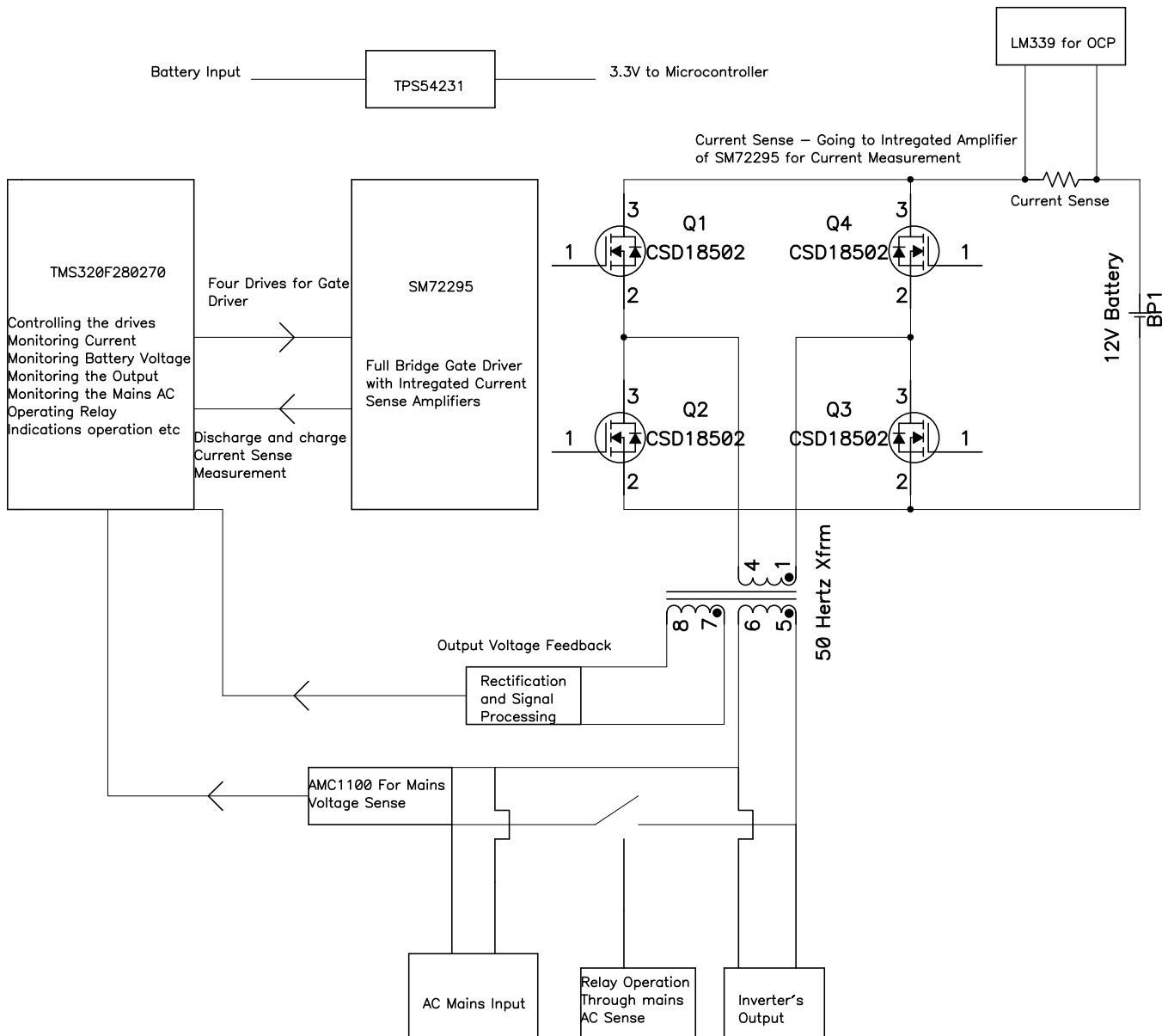

Figure 2. Block Diagram of 600VA to 3 KVA Residential Pure Sine Wave Inverters

There is a dual mode of operation in a residential Inverter, that is, Mains mode and Inverter modes shown in [Figure 2](#).

An Inverter not only converts the DC Voltage of battery to 220-V/120-V AC Signals but also charge the Battery when the AC mains is present. The block diagram shown above is a simple depiction of the way an Inverter Works.

2.1.1 Inverter Mode:

The method, in which the low voltage DC power is inverted, is completed in two steps. The first step is the conversion of the low voltage DC power to a high voltage DC source, and the second step is the conversion of the high DC source to an AC waveform using pulse width modulation. Another method to complete the desired outcome would be to first convert the low voltage DC power to AC, and then use a transformer to boost the voltage to 120/220 volts. The widely used method in the current residential inverter is the second one and hence this reference design is based on this method.

The AC input is sensed through isolated amplifier (AMC1100) and the isolated replica of the AC input is given to the TI's Picolo Lite Microcontroller ADC. When the AC input is not present in Valid range (Inverter mode) or AC fails, the relay between Mains AC Input and the Inverter Output remain open, the microcontroller generates PWMs and send four drives output to Gate Driver (SM72295). Now the Gate Driver accepts low-power inputs from the controller and produces the appropriate high-current gate drive for the power MOSFETs placed in Full Bridge Topology.

Here H-bridge circuit converts battery DC voltage into AC using high frequency PWM (6 kHz to 20 KHz) thus feeding the 50-Hz transformer which Boost it to 120V/220V AC. The output of transformer contains a capacitor which filters it to make clean 50-Hz AC.

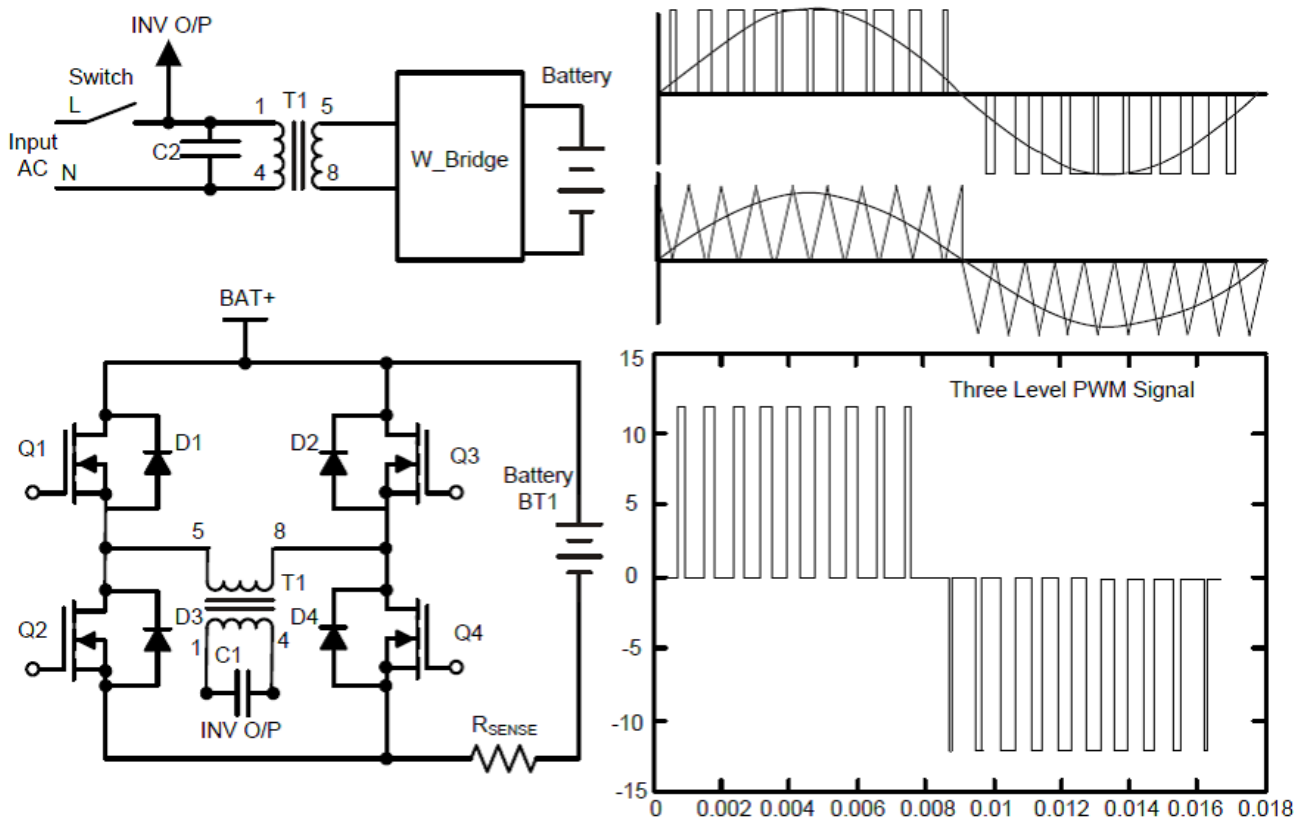

Figure 3. Inverter Mode Gate Drives

As seen from the Block Diagram (Figure 3), the Output Voltage is Sensed through the Auxiliary Secondary Winding and feeds to the Controller. The Controller takes this feedback and then Work on the PWM to generate the regulated AC output.

Furthermore the current that is flowing through the battery in Inverter mode and the Charging current during the Mains mode is measured using Integrated Amplifiers of SM72295 and given to the ADCs of the Microcontroller.

Also this reference design has additional protection for Over current Discharge (OCD) and Over Current Charge (OCC) using LM339 Comparators where the amplified Voltage output across Current sense is compared with a pre determined Value and the PWM is immediately shut down by the controller if either the OCD or OCC limit is crossed .

2.1.2 Main Mode:

In the mains mode, when the input AC is present and is within valid range, the relay between Input AC and the inverter output is closed and the input AC directly goes to the output load. The same AC is fed to transformer, and the H-bridge consisting of MOSFETs or IGBTs are driven through microcontroller to charge the battery. A bridge less rectification principle is used to charge the battery where basically both the high-side FET is switched off and both lower side FETs to ground in the H Bridge are switched at the same time with the duty Cycle proportional to the Battery Charge current.

Whenever the lower FETs are turned ON at the same time, that is, there is a generation of boosted voltage across the leakage inductance of the primary inductance connected to H Bridge by the Ldi/dt effect and this energy stored in the Leakage Inductance flow through the body diode of the high-side MOSFETs (Each high-side MOSFETs body diode conducts on AC half cycle) and charge the Battery. Hence the charging current is proportional to the duty cycle of the PWM switching on lower side FETs.

2.2 Switching Waveform Details

To understand the functioning of an Inverter, the user must understand the switching requirement of the four drives of the MOSFETs in H Bridge both in Inverter as well as Mains mode.

1. Inverter Mode

The Switching Wave Form in an Inverter is very simple to understand and generate.

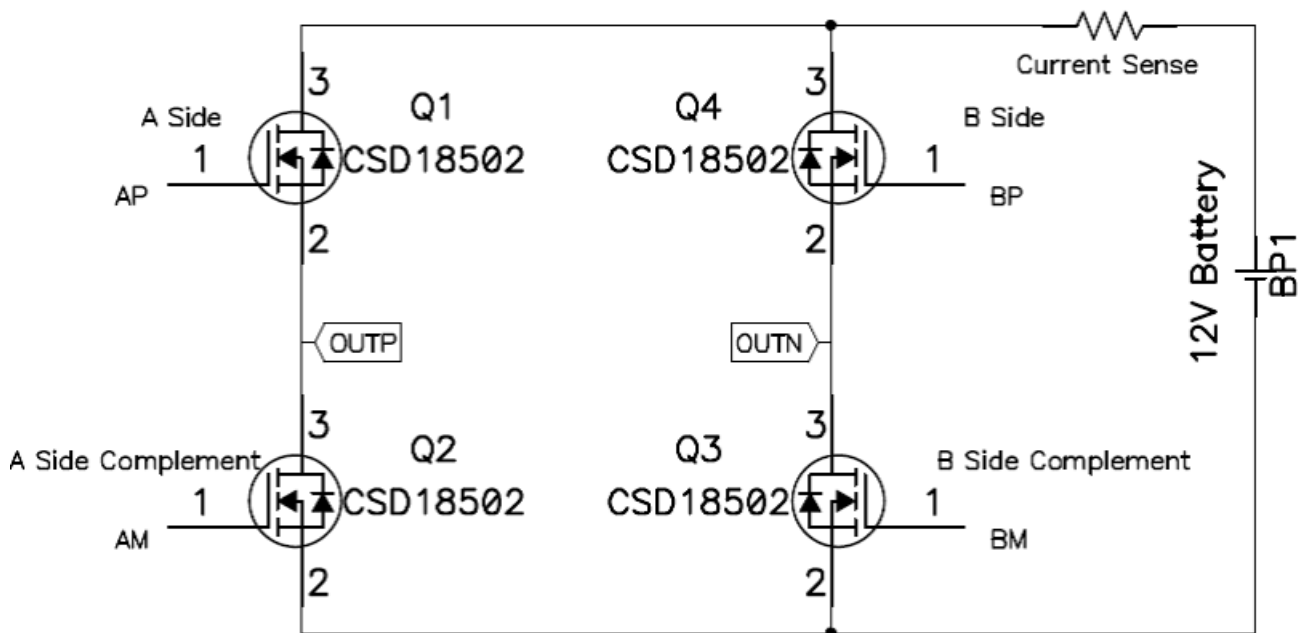

Figure 4. H Bridge Configuration of MOSFETs

On the A Side MOSFET of the H Bridge, the PWM is generated by modulating the Sine Wave with high frequency (6 KHz to 20 KHz) Square wave in such a way that the positive peak of the Sine Wave is represented by maximum duty cycle and the negative peak by the minimum duty Cycle as shown in [Figure 5](#).

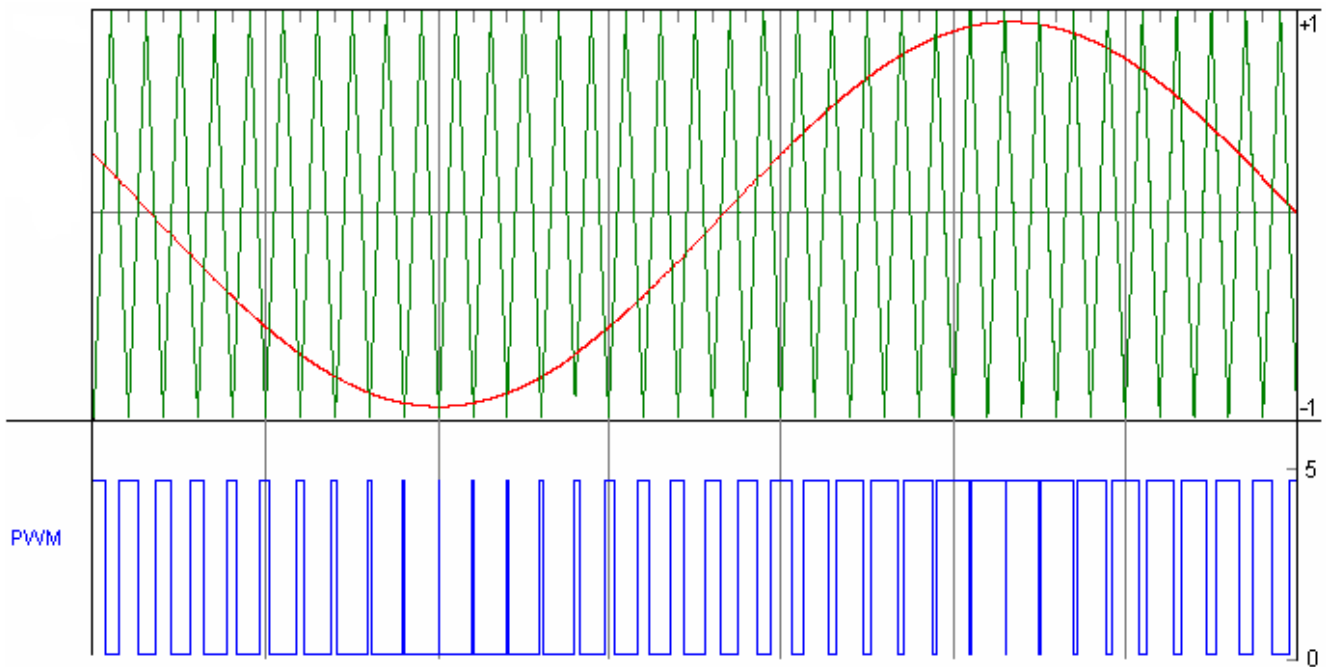

Figure 5. Modulation of Sine Wave With Higher Frequency PWM Signals

Now on the B Side, just phase shift this Sine Wave by 180 degree and generate the PWM in a similar Way as mentioned above. The following simple hardware implementation of the PWM generation will make the design more clear.

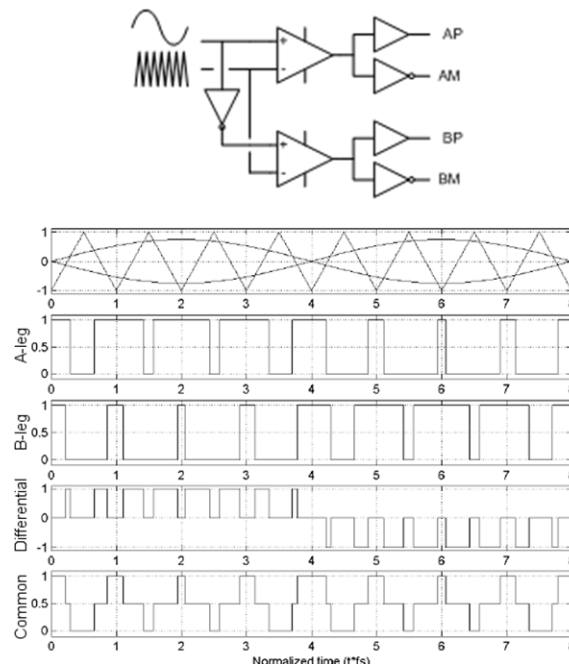

Figure 6. Waveform Generation in Inverter Mode

A side complementary or the AM signal is obtained by just inverting the A side or AP waveform and the same goes for B Side complementary or BM waveform.

The differential signal seen across the OUTP and OUTN will be a Trilevel PWM Signal as mentioned in Figure 7:

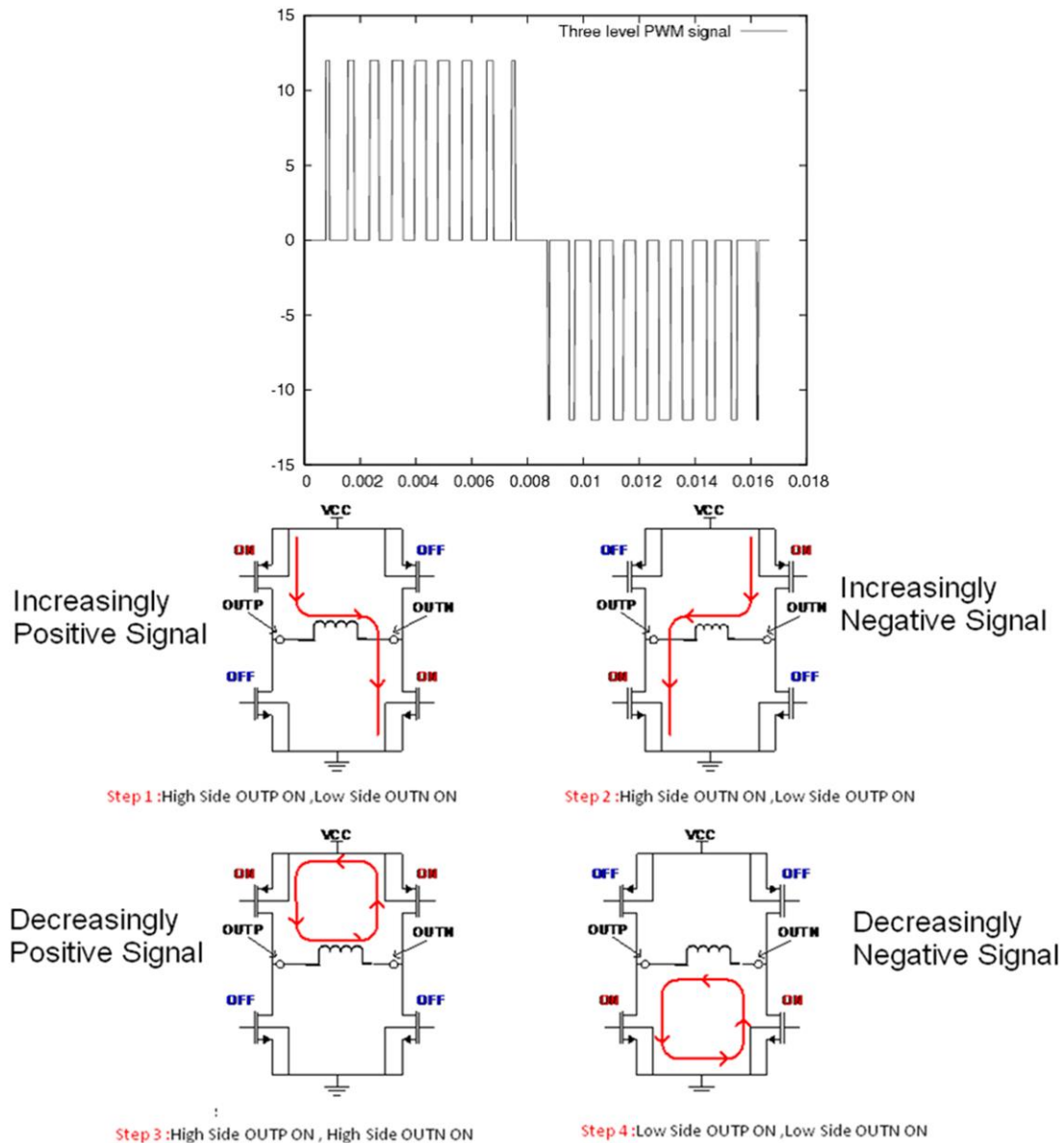

Figure 7. Trilevel PWM Signal During the Inverter Mode for Pure Sine Wave Generation

2) Mains Mode:

In the mains mode, both the high-side MOSFETs ie A side as well B side is switched off and both the low-side MOSFETs are switched with the similar PWM waveform where the duty cycle of lower side PWM signals determine the charging current.

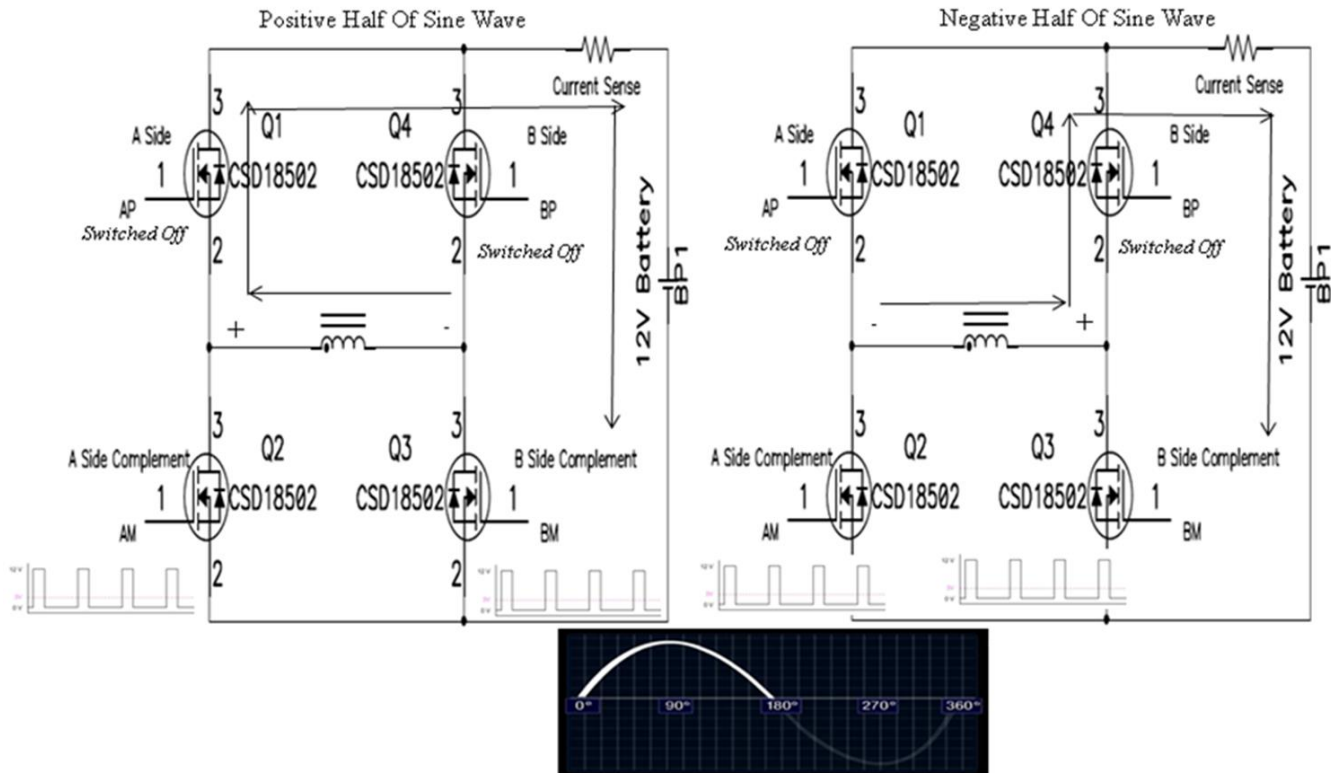

Figure 8. Charging Mode PWM Switching Explanation

When the lower switches are turned on at the same time, there is a boosted voltage, that appear across the primary leakage inductance of transformer connected to the H-Bridge, by the $L di/dt$ effect and this energy is use to charge the battery through the body diodes of the high-side MOSFETs. Also each of the high-side MOSFET's body diode will conduct in the each half of the Sine Wave.

When the mains mode is sensed, firstly all the MOSFETs are switched off and the Relay between the Ac input and the Inverter output is connected. After this, the Lower FETs are tuned on with PWM of small duty Cycle (5 to 10 percent) and the high-side MOSFETs are switched off. Now the voltage across the current sense is measured by controller and if the corresponding current is less or more than required by charging algorithm than the duty cycle is altered correspondingly ie duty cycle is increased if more charging current is required and decreased if the charging current reduction is desired.

2.3 Schematic of the Design

The schematic is divided into two boards:

- 1) Main Power's Board
- 2) Microcontroller's Daughter Card

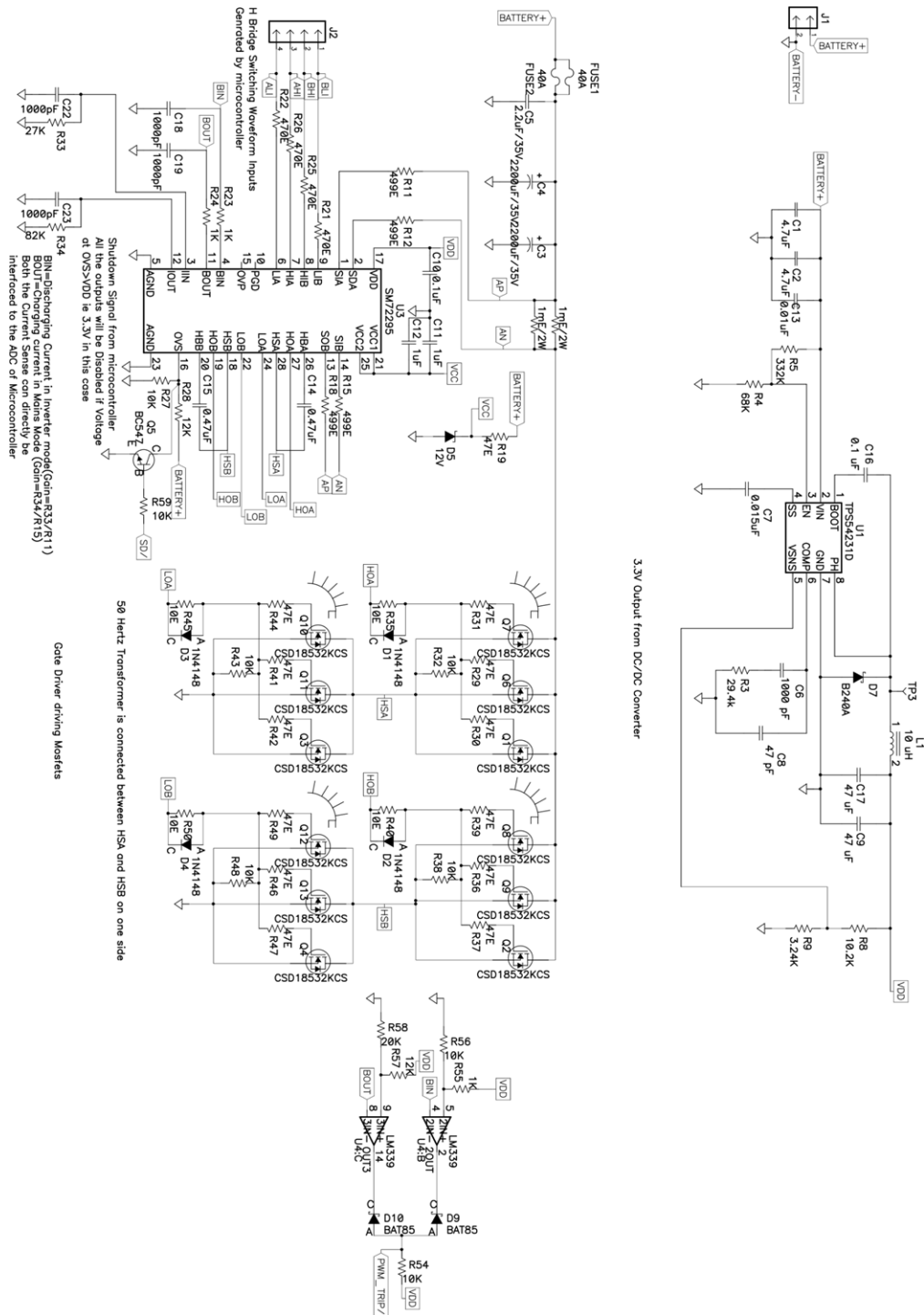

Figure 9. Main Board's Schematic

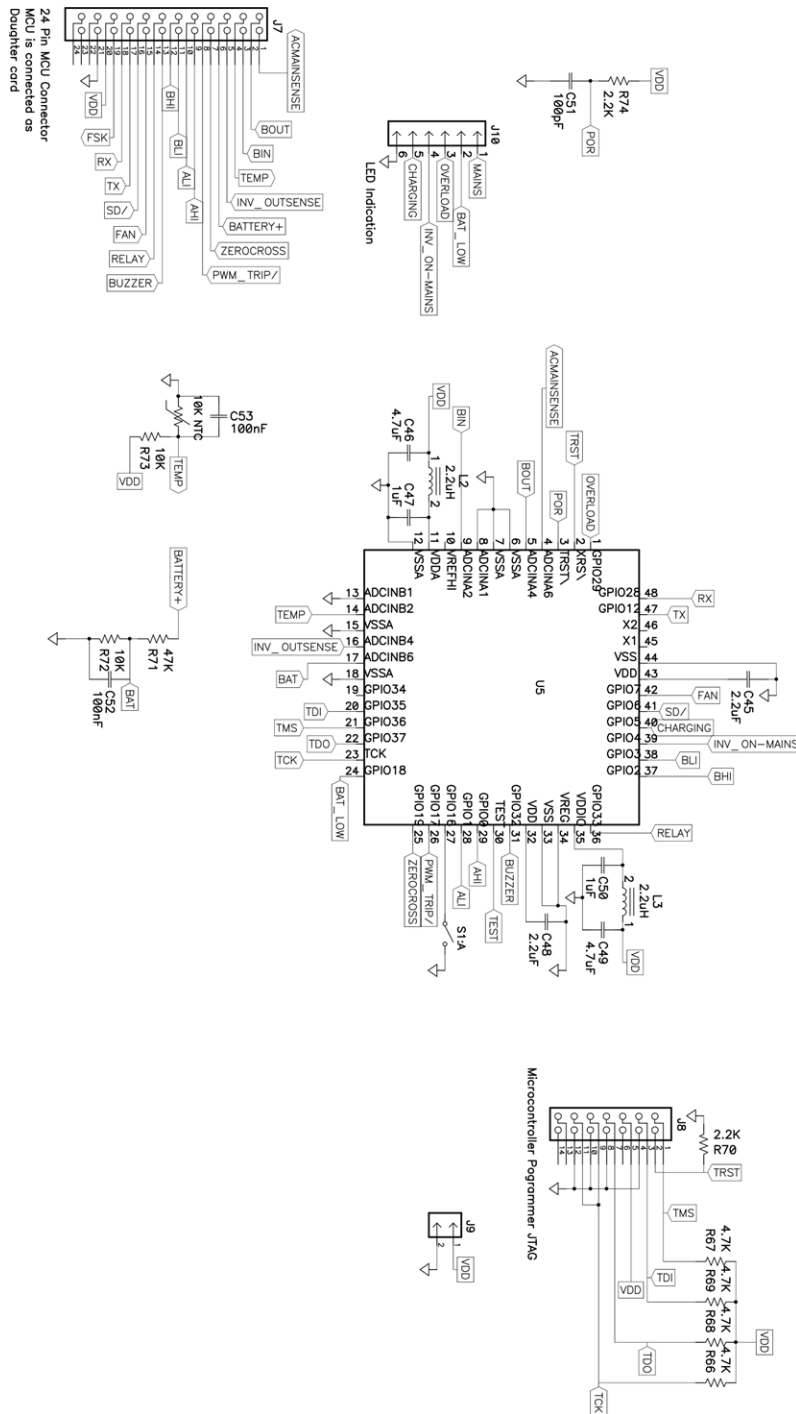

Figure 10. Microcontroller's Daughter Card

2.4 Sections of the Design:

1) 12-V Battery Input to 3.3-V Conversion:

TPS54231 buck converter is used to convert battery voltage (nominal 12 V) to 3.3-V output which in turn is mainly used to power the Controller daughter card and AMC1100 Isolated amplifier secondary side.

The TPS54231 DC-DC converter is designed to provide up to a 2 A (our requirement is a maximum 200 mA) output from an input voltage source of 3.5 V to 28 V, and this integrates a low-RD_{SON}, high-side MOSFET. Further details to the IC can be found from the below links:

[TPS54231: 3.5- to 28-V Input, 2-A, 570-kHz Step-Down Converter With Eco-Mode™](#). Click [here](#) to download the data sheet. Below is the design of DC/DC Section:

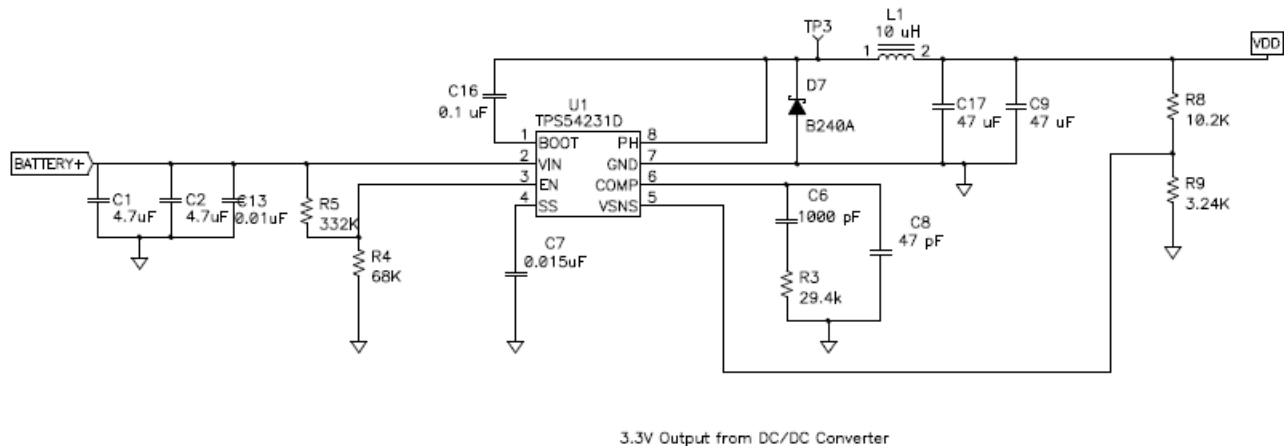

3.3V Output from DC/DC Converter

Figure 11. DC-DC Converter's Design

2) Highly Integrated Gate Driver Design :

Gate Driver is a power amplifier that accepts a low-power input from a controller IC and produces the appropriate high-current gate drive for a power MOSFET. The gate driver must source and sink current to establish required V_{gs}.

Here the SM72295 is used as a full bridge MOSFET driver which has 3-A (higher number of FETs in parallel for high power) peak current drive capability and has the following advantages:

1. Integrated ultra-fast, 100-V boot strap diodes (can easily support up to 5KVA rated inverters)
2. Two high side current sense amplifiers with externally programmable gain and buffered outputs which can be used for measuring the battery charge and discharge current – Additional current sense amplifiers and buffers are not required
3. Programmable overvoltage protection – which can be used for charge complete detection or for driver shutdown feature in case of a fault condition
4. Can be directly interfaced with a microcontroller

The complete design principles and circuit details of SM72295 in the Inverter application can be found in the referenced application note (the also includes the current sensing sections of the design):

[AN-2296 SM72295: Highly Integrated Gate Driver for 800VA to 3KVA Inverter](#) (SNVA678).

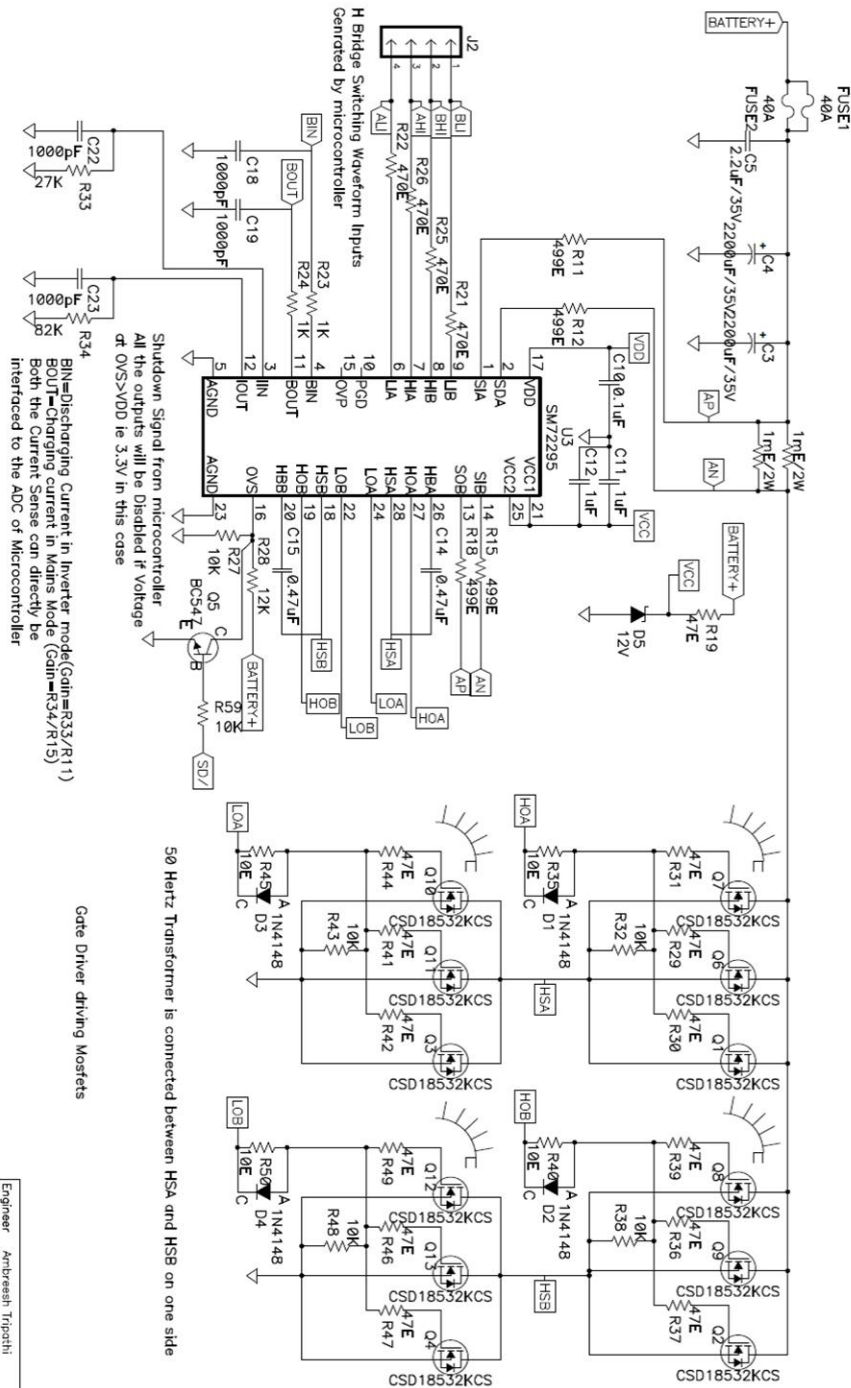

Figure 12. Gate Driver and Current Sensing

3) Over Discharge Current and Over Charge Current Protection Implementation:

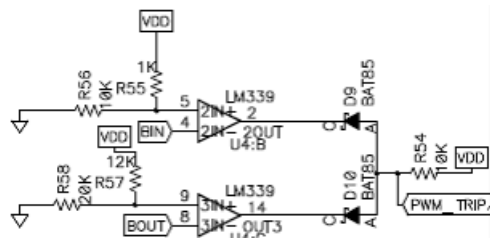

Figure 13. ODC and OCC Protection

Here BIN is the voltage across the current sense resistance during the inverter mode and BOUT is the voltage across the current sense during the Mains mode. Now both of these are compared to the different reference voltages, and the PWM is tripped once either BIN or BOUT exceed their given reference voltage.

Setting the reference point during the charging and discharging mode is very simple.

Now with the integrated amplifiers on the SM72295, the gain on the voltage across the current sense during the discharging mode is 27K/499E (ratio of resistance on IIN and SIA pin of SM72295) and during the charging mode is 82K/499E.

To put the over discharge current protection (ODC) at current = 110 A. The drop across the current sense will be current sense resistance \times ODC = 0.055 V. Now the gain of 27K/499 is given and the BIN = 3 V approximate. The reference of 3 V is given as ODC protection reference and similarly over charge current protection reference (of 25 A) has been put as 2 V.

4) Input AC Mains Sensing Using Isolated Amplifier:

In the traditional design of Commercial 600 VA - 5 KVA inverters, the AC mains voltage is sensed by stepping down through a bulky 50-Hz transformer by the microcontroller, which is powered up by battery through linear regulators. To ensure the operator safety (personal handling battery, and so on) and signal integrity, galvanic isolation is required in the design.

The input AC Voltage Sensing is required in inverters for changing to Mains mode through relay operation when A/C mains fall in the designated voltage level. Further comparators are also used in addition with transformer for location of zero crossing point of sinusoidal A/C signal.

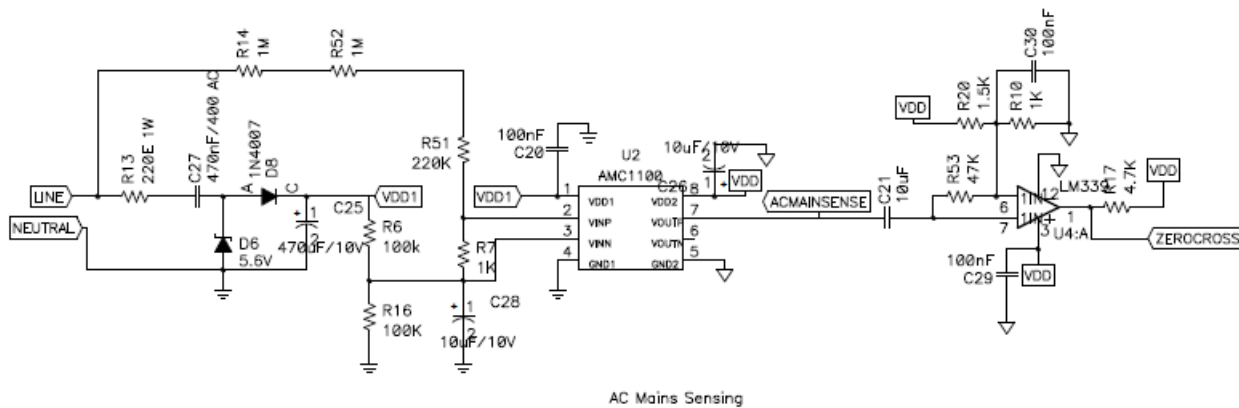

Figure 14. AC Mains Sensing Through Isolated Amplifier

The complete design principles and circuit details of isolated amplifier AMC1100 in the inverter application can be found in the referenced application note:

[AMC1100: Replacement of Input Main Sensing Transformer in Inverters with Isolated Amplifier \(SLAA552\)](#)

5) Relay Operation:

In the mains mode, when the input AC is present and is within valid range, the relay between input AC and the inverter output is closed and the input AC directly goes to the output load. Basically one terminal of the Output (OUTL in this design) is shorted to the line input of the mains and when the relay is turned on neutral get connected to the OUTN and hence the AC input becomes the inverter's output.

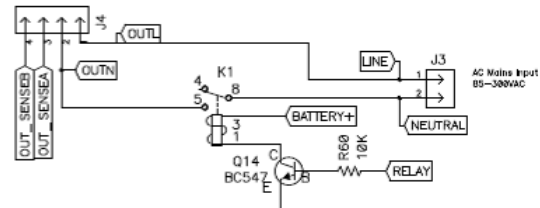
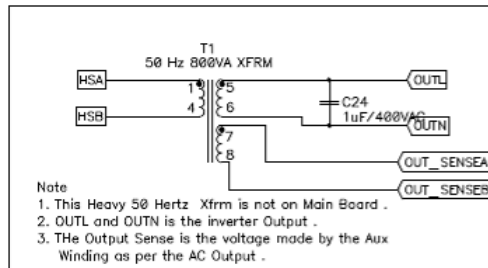

As indicated in the Schematic, Output of Inverter OUTL and OUTN is placed at the pin 1 and Pin2 of Header J4. When Valid AC is present, Relay is switched and Output of the Inverter is equal to Mains Input.

Figure 15. Relay Operation

6) Inverter's Output Voltage Sense in Inverter Mode, DC FAN Operation for Cooling MOSFETs and Error Buzzer Operation:

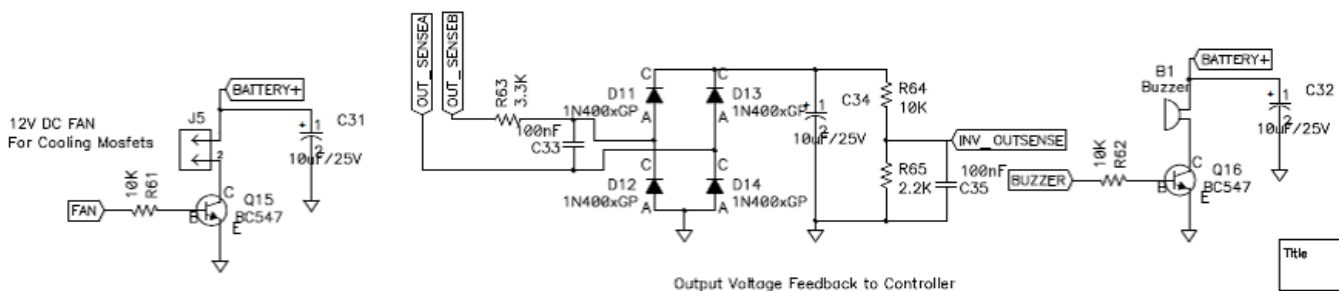

Figure 16. Output Sense, DC Fan, and Buzzer Operations

The Output Voltage in Inverter mode is sensed through the Auxiliary winding, which is filtered and rectified and given to the ADC of the microcontroller. When fall in the output voltage is sensed with the increase in the output load, the duty cycle of the H Bridge drive (from microcontroller) is multiplied by a constant greater than 1 so that the final inverter's output voltage is closer to the no load output voltage (120V/220 VAC) and vice versa on moving from higher load to the lower load.

For example, in this reference design, at no load condition, the duty cycle of the PWM drives given to the H Bridge are varied from 10 percent to 88 percent and when the load is constantly increased at the Inverter's output, the duty cycle of the PWM is multiplied by a factor greater than 1 so that we can regulate the output voltage within allowable range. While decreasing the load, vice versa followed.

If the duty cycle is increased beyond a point, the output voltage will start clipping, and hence results in higher distortion. Therefore, take care while regulating the output voltage through a feedback.

7) Microcontroller's Daughter Card:

This card has TMS320F280270 MCU, JTAG connector for programming and connector for interfacing all signals with main board. This is a digital power application and most of the MCUs available in the market that finds use in digital power are 16-bit MCUs. TI offers C2000 - 32 bit MCU which can offer good performance which is most wanted in such applications. TMS320F280270PT is C2000 piccolo family MCU series which has unique peripherals like 3 ePWM channels with 6 outputs, 8 channels of the 12-bit, high-speed SAR ADC, 22 digital GPIO shared with digital peripherals with a high performance 50MHz CPU for this application. In this design, all analog and digital pins are being used; however, they can be mapped in different way according to application change if required.

ePWM has Counter compare, action qualifier, dead band, trip zone sub modules with internal connections of channel. Using these central aligned complementary PWM outputs is generated through ePWM output pins with phase shifting of 180 between ePWM1 and ePWM2 channel outputs. TI provides a very efficient IQ match library using which sine wave is generated very easily within fast loop of 50 μ S.

This MCU has 12-bit SAR ADC, which can be configured from 7 cycle to 64 cycles long sampling. Using same, one can get very fast feedback signal for adjusting output voltage during inverter mode and charging current in charging mode. ADC is being triggered by 20-KHz PWM, so for every 50 μ S, all samples are ready for feedback correction. ADC ISR is being used as control loop function and due to IQ math total time taken for Sine Wave generation, Output correction/charging current correction is around 7 μ S.

TMS320F2802x0 I/Os are supported by programmable digital filter for each one of them, making the MCU glitch protected and application development easy with ruggedness.

The Daughter Card is connected to the main board through the 24-pin connector. The controller card performs following main functions:

1. The AC Mains voltage is sensed, and based on this, the relay is operated. (ACMAINSENSE and RELAY)
2. Than the four drives are generated by controller and given to the Gate Driver Inputs. (ALI,BLI,BHI and AHI)
3. The charging current (BOUT) in the mains mode and the discharging current (BIN) in the Inverter mode is continuously tracked and in the error state, PWMs are tripped.
4. Also in the inverter mode, the output voltage of the Inverter is sensed (INV_OUTSENSE) and the duty cycle of the switching PWMs are modified to achieve the regulation in the output voltage.
5. Battery voltage and the temperature of the heat sink is also continuously monitored.
6. Based on the load in the inverter mode or temperature rise of the heat sink, the DC fan is operated.
7. Various LEDs indications are given for user interface.
8. Buzzer is operated if there is any detection of error state in the main board.

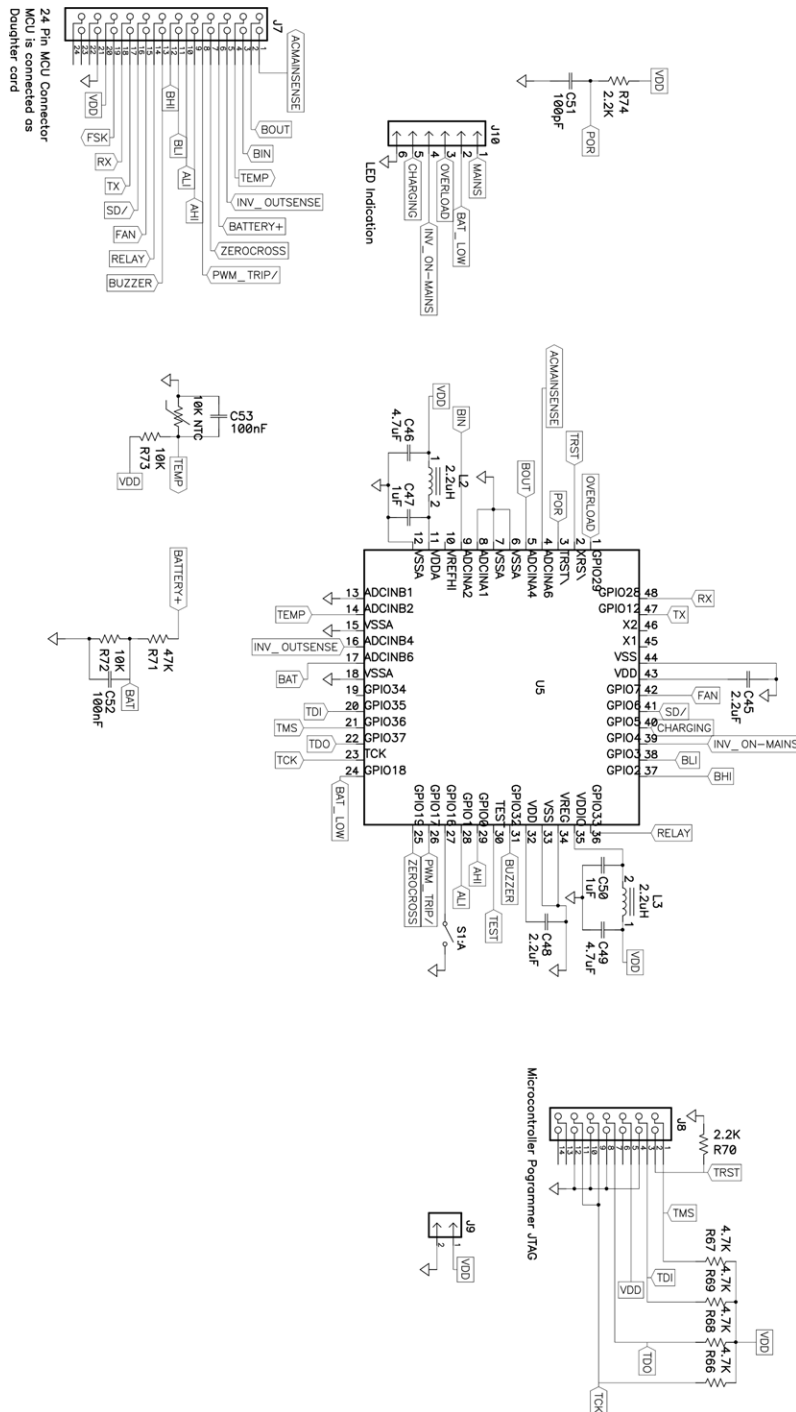

Figure 17. Daughter Card's Schematic

2.5 Required Steps While Debugging/Working on the Hardware

1. The main power board must be checked first, and therefore, the daughter card must not be placed initially. Also, all the initial testing should be done on current limited Lab Power Supply
2. The DC-DC output on the main board is checked for 3.3-V output. Then both (the logic voltage VDD and VCC) the power supply of the SM72295 is checked. The voltage at VCC1 and VCC2 of SM72295 should be 10.5 V with the 12-V input battery.

3. The daughter card should be programmed with the basic inversion software to generate required 4 drives to operate the H – Bridge. Before inserting the Daughter card, the fuse F1 should be removed so that the PWM switching can be seen at the gates of each of the MOSFETs.
4. Now the input drives to the microcontroller be compared with the gates waveform and it is needed to be insured that A side waveform is complementary to the A side complementary waveform and similar for the B side waveform.
5. Now the fuse should be placed on the main board so the H – Bridge gets connected to the power supply. Again all the gates of the MOSFETs has to be monitored. The low-side FETs will be switching at 12-V rail while the high-side FETs will switched at higher rail (gate voltage must be 6 to 12 V higher than the source voltage (12 V), which is achieved through boot strap circuits of the gate driver).
6. The differential signal seen across the high-side MOSFETs sources (OUTP and OUTN) will be a Trilevel PWM signal as mentioned below:

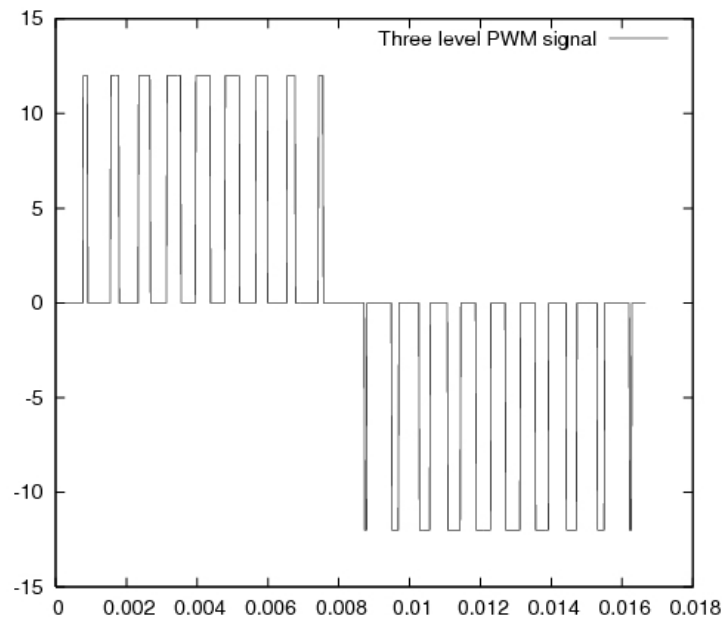
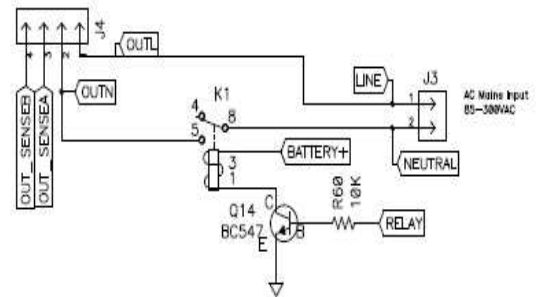
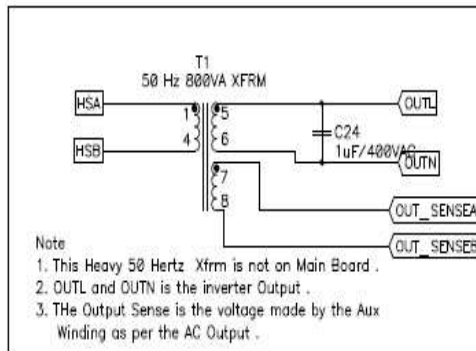

Figure 18. TITLE??

7. Now the 50-Hz boost transformer is placed across OUTP and OUTN and the output is filtered through 1- μ F/400-VAC capacitors at the inverter output. The inverter output should give 220-V AC signal. Auxillary winding output at INV_OUTSENSE be noted and used to program the feedback loop to have regulated output.
8. The current sense amplification is checked in the inverter mode and the over discharge current protection is tested by increasing load at the output. (Until the no load condition at the output is met??, the lab power supply can be used, and when increasing the load, the 12-V/150-AH battery can be used)
9. All the above stated steps are for the basic inverter testing of the design. The steps below are required for the main mode testing.
10. Initially, the output of the inverter is not connected to Pin 1 and 2 of Connector J4. The priority is to first check the relay operation. Now when AC input is given to connector J3, it is sensed through the AMC1100, the output of which is connected to the ADC of the microcontroller. Once it is in valid range, firstly all the inverter mode PWM switching is stopped and the relay is switched.



As indicated in the Schematic , Output of Inverter OUTL and OUTN is placed at the pin 1 and Pin2 of Header J4 .
When Valid AC is present , Relay is switched and Output of the Inverter is equal to Mains Input .

Figure 19. TITLE?

11. The output of the Inverter (that is, OUTL and OUTN) is connected to Pin 1 and Pin 2 of the Connector J4, hence why the mains Input becomes the inverter output through the switched relay.
12. After this, the lower FETs are tuned on with a small duty (5 to 10 percent) and the high-side MOSFETS are switched off. Now the voltage across the current sense is measured by controller and if the corresponding current is less or more required by charging algorithm than the duty cycle is altered correspondingly that is, duty cycle is increased if more charging current is required and decreases if the charging current reduction is desired.
13. Finally, the switching between the Inverter mode and mains mode is checked by inserting or removing the Input AC mains signals.

2.6 Waveforms and Test Results of 800VA Sine Wave Inverter's Reference Design:

1. Inverter Mode Waveform :

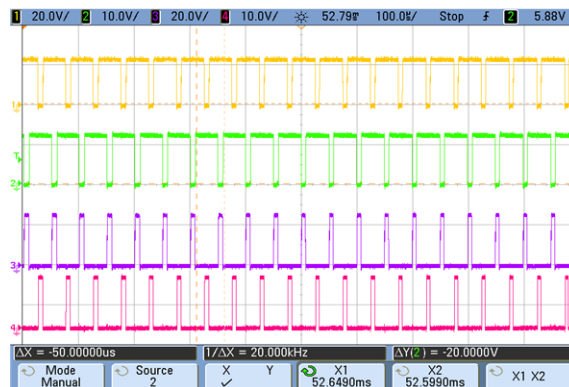
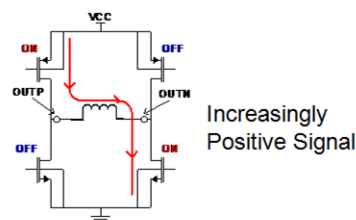

Figure 20. Waveforms at the Gates of the MOSFETs in Inverter Mode (High-Side A MOSFETs and Low-Side B MOSFETs are Conducting).

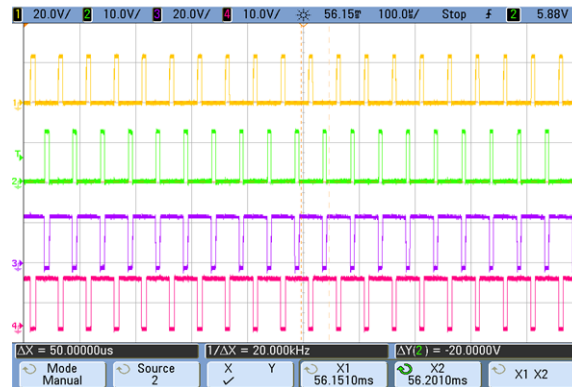
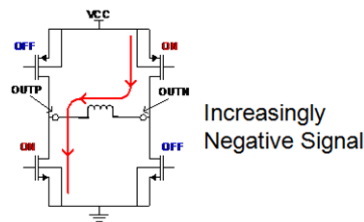

Figure 21. FIG 17: Waveforms at the Gates of the MOSFETs in Inverter Mode (High-Side B MOSFETs and Low-Side A MOSFETs are Conducting).

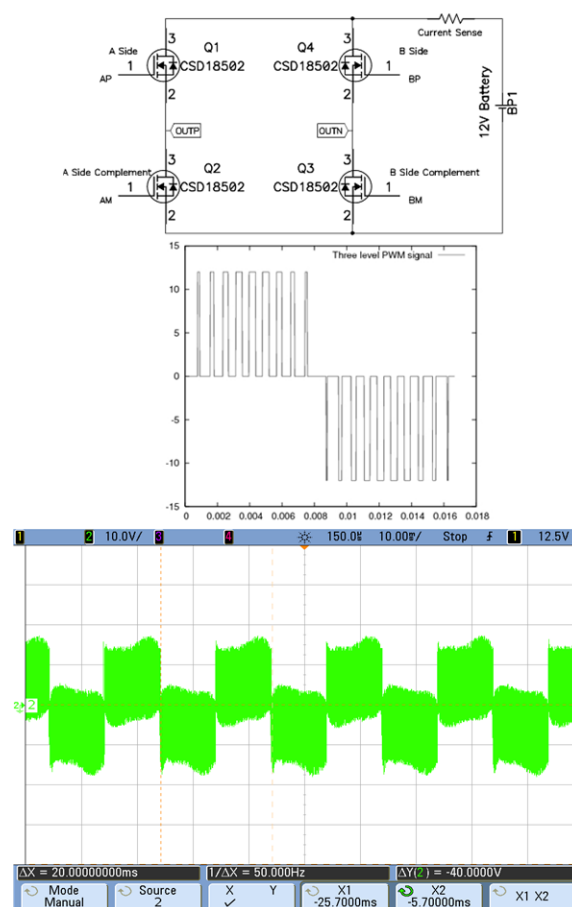

Figure 22. Trilevel Switching Across the High-Side A MOSFETS Source (HSA) and High-Side B MOSFETS Source (HSB).

Trilevel Switching Zoomed in:

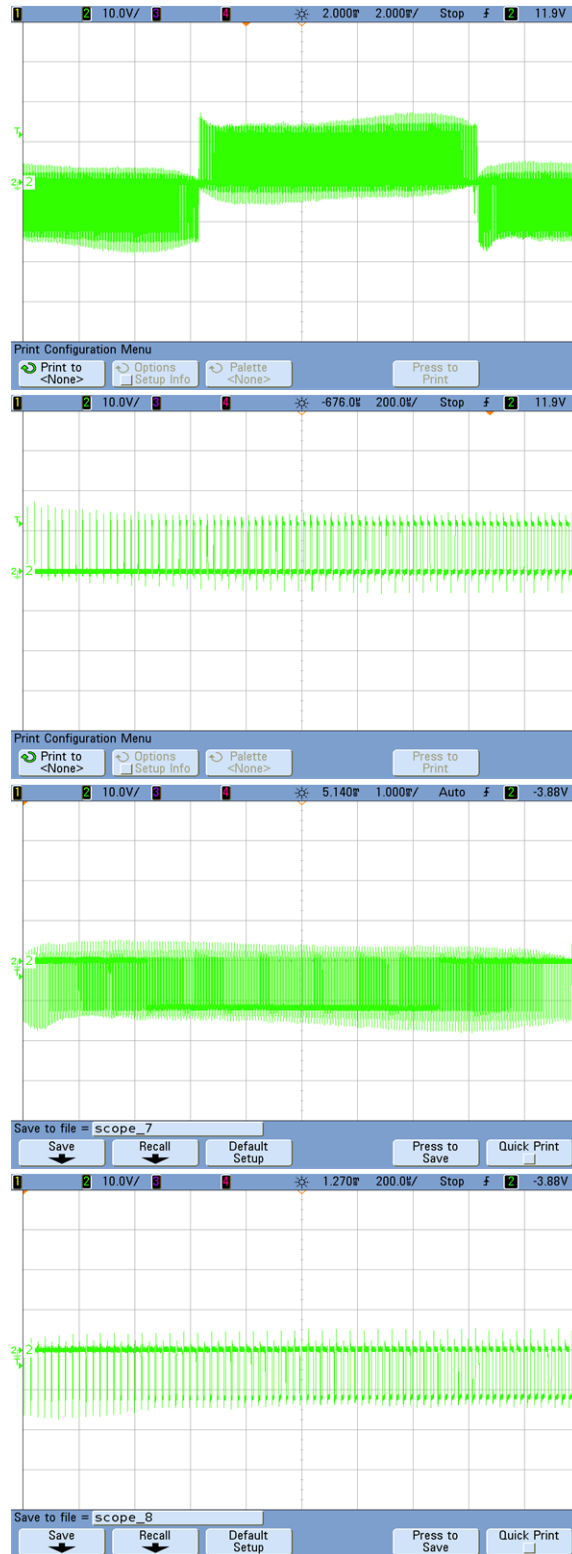

Figure 23. Trilevel Switching Across the High-Side A MOSFETS Source (HSA) and High-Side B MOSFETS Source (HSB).

Insuring the dead band between complementary waveform to avoid the short-circuit condition:

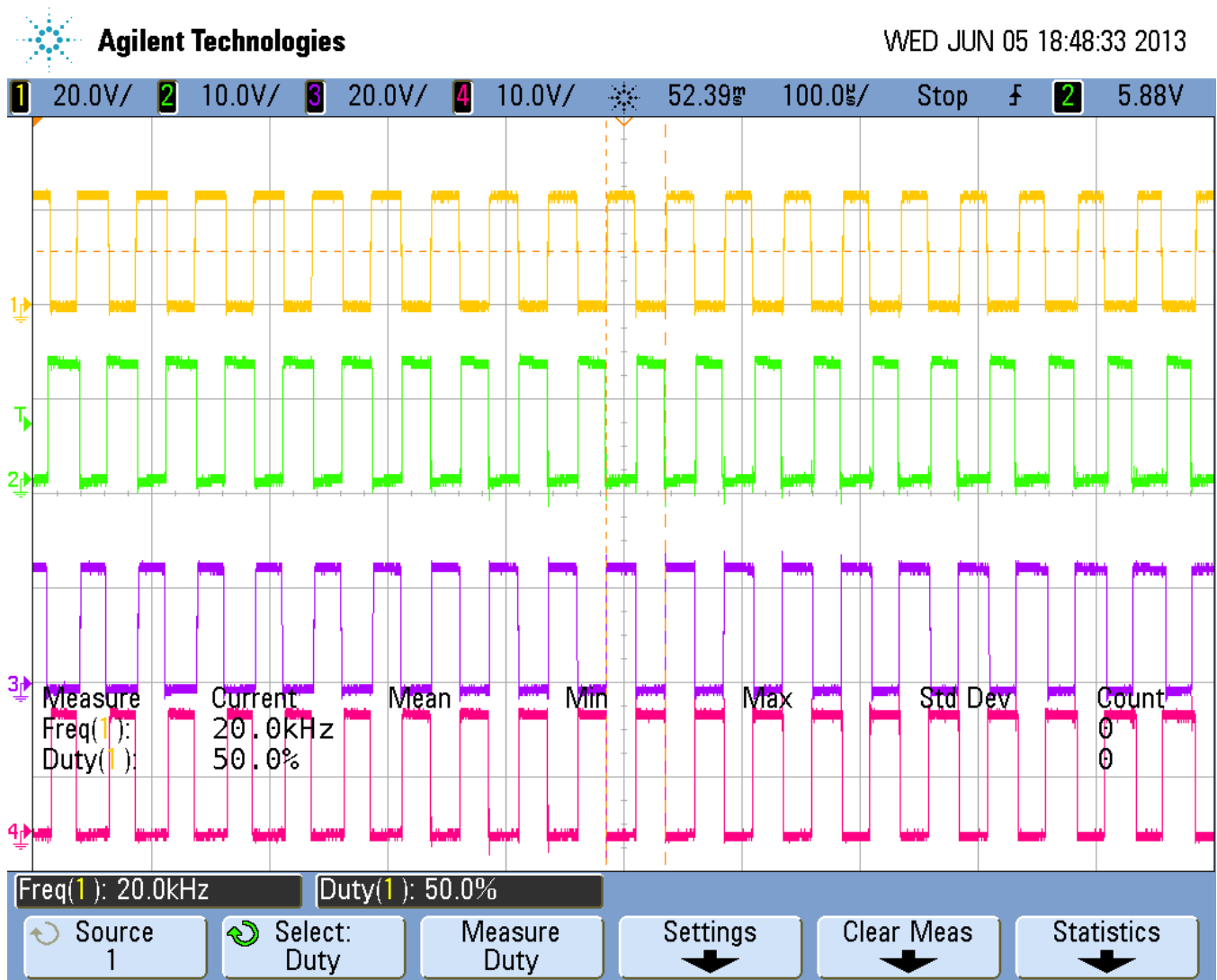

Figure 24. Inverted Waveform (HOA-LOA and HOB-LOB) at the Gates of MOSFETS.

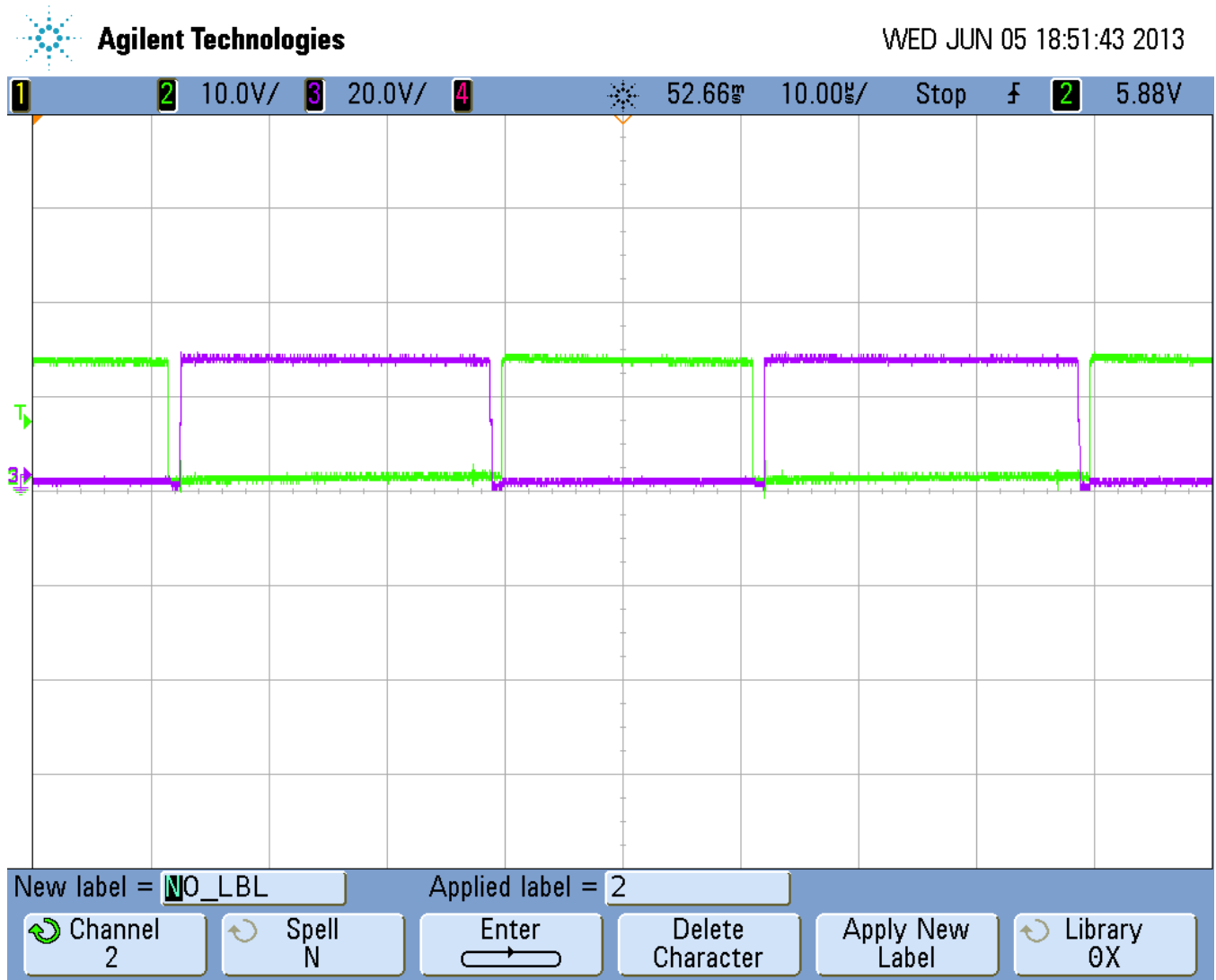

Figure 25. Dead Band between Complementary HOB and LOB Pair

PWM switching at the gates of the MOSFETs at no load (inverter mode) with 12-V battery input:

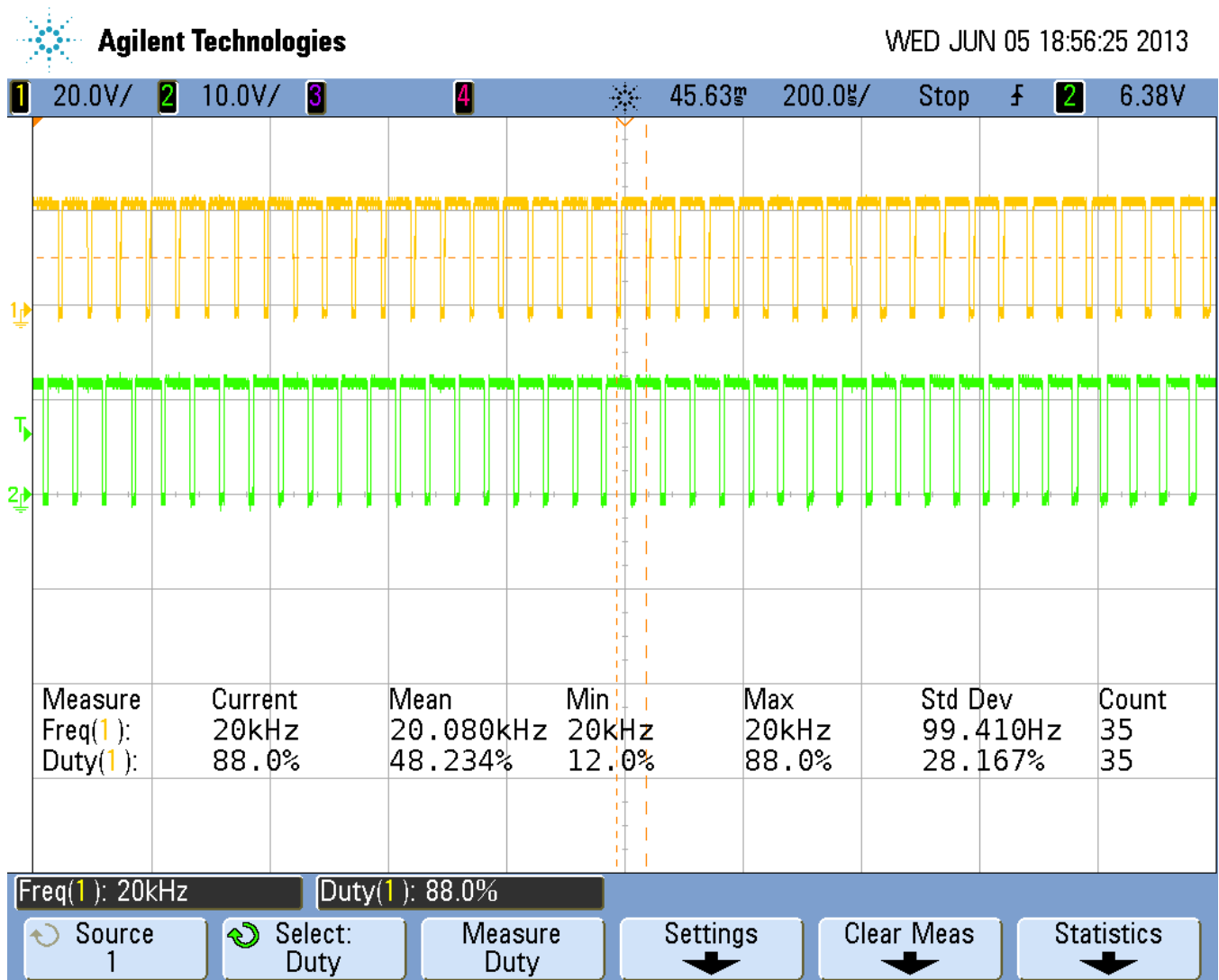

Figure 26. Maximum Duty Cycle of the PWM Switching at No Load (at the Inverter's Output) is 88 Percent

PWM switching at the gates of the MOSFETs at 400 W (inverter mode) with 12-V battery input:

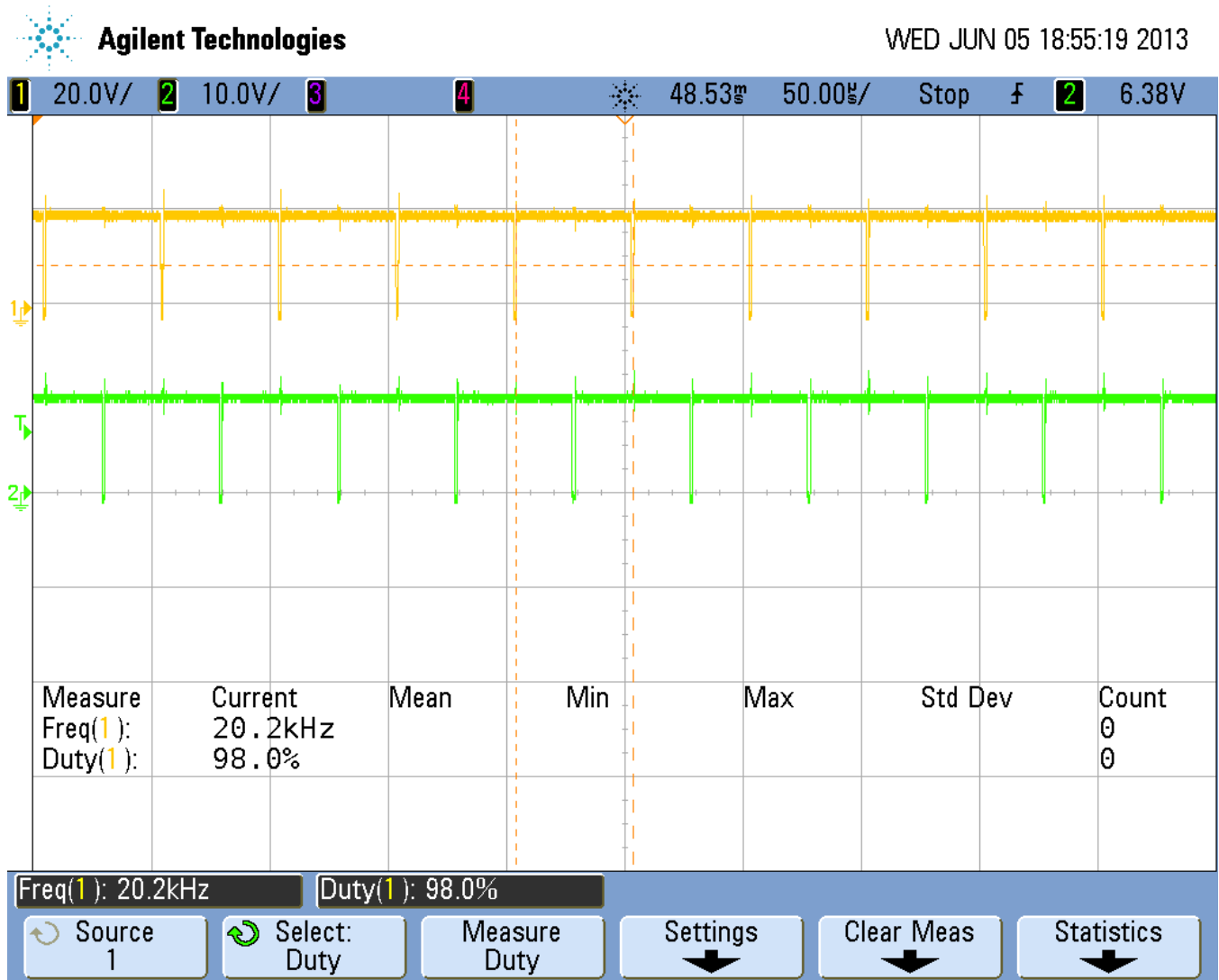

Figure 27. Maximum Duty Cycle of the PWM Switching at 400 W (at the Inverter's Output) is Increased to 98 Percent to Maintain Voltage regulation at the Inverter's Output by Sensing the Auxiliary Winding. This Results in Slight clipping of Sinusoidal Waveform at the Output.



WED JUN 05 17:01:27 2013

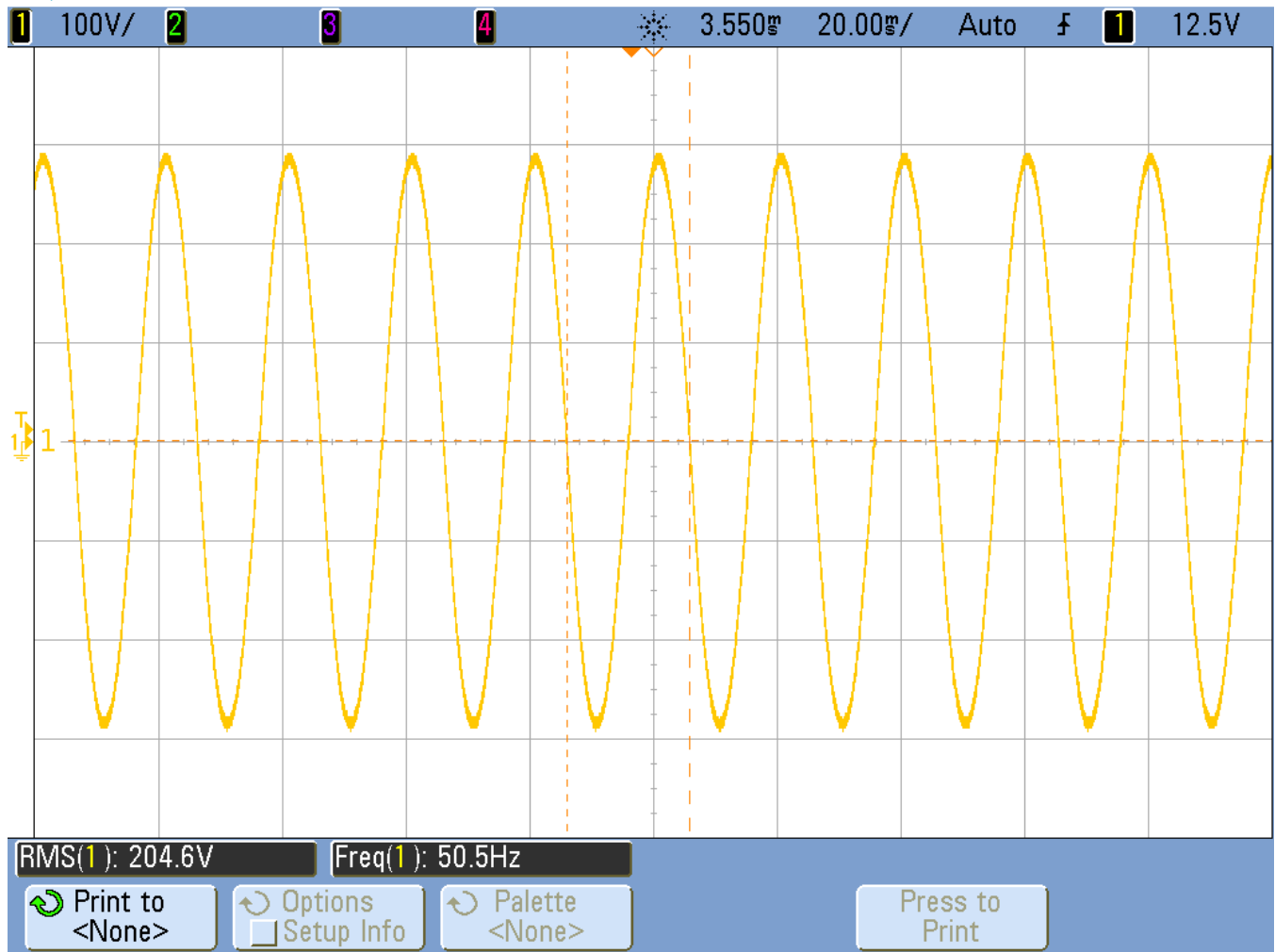

Figure 28. Inverter's Output at No Load With 12-V Battery Input



WED JUN 05 17:02:34 2013

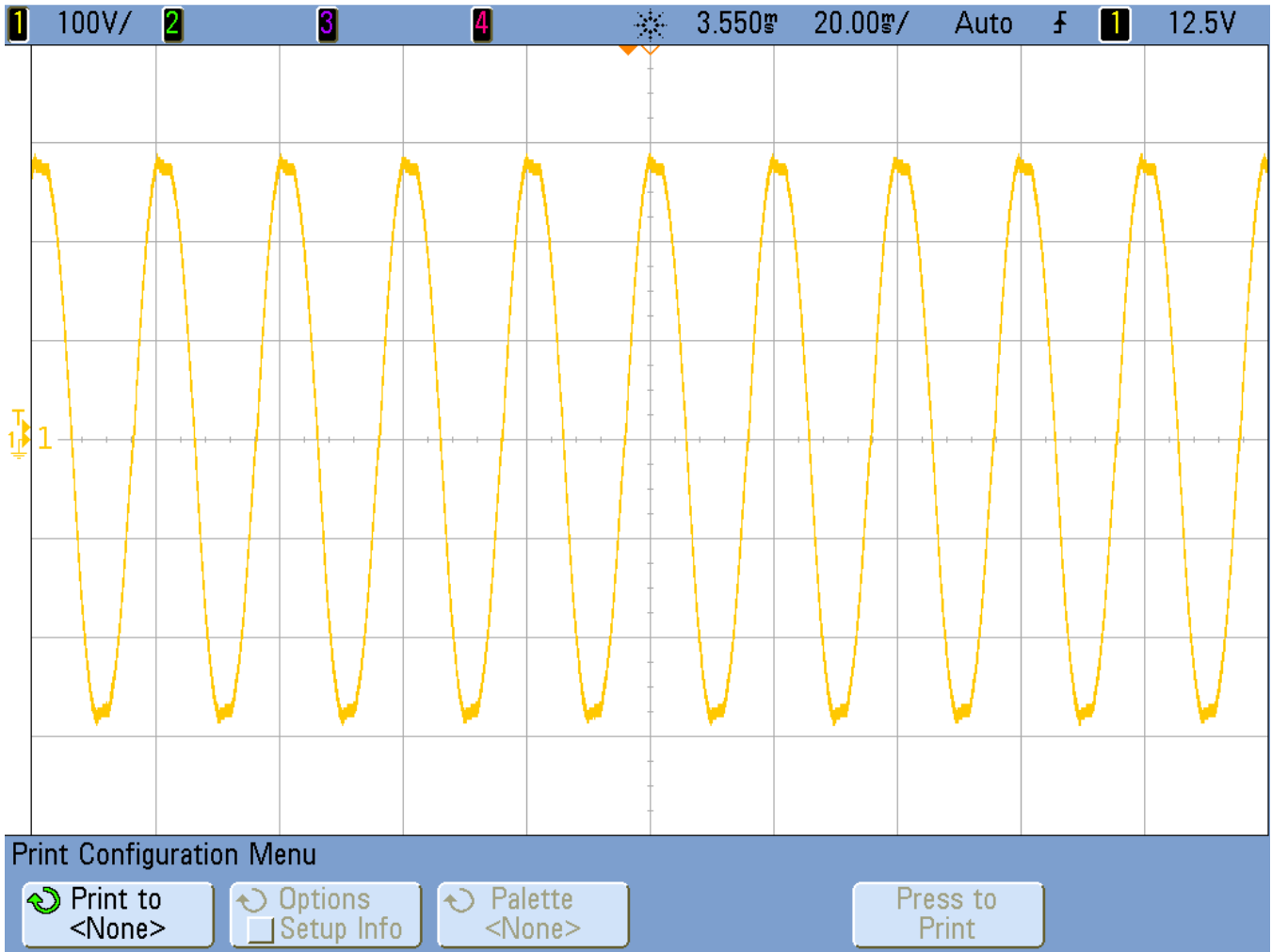

Figure 29. Inverter's Output at 400-W Load With 12-V Battery Input

Mains/charging mode waveform:

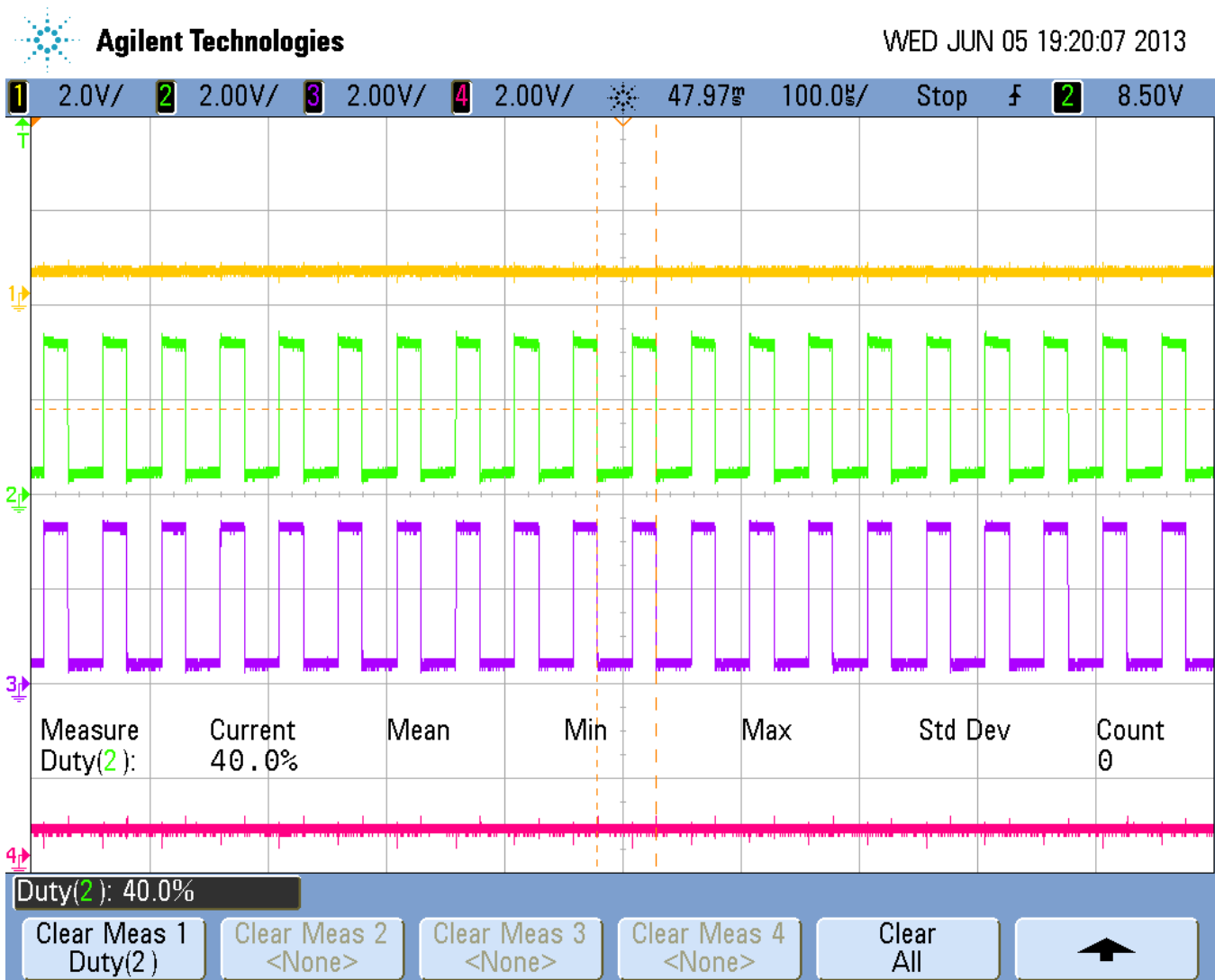

Figure 30. Waveform During the Charging Mode. The High-Side FET is Switched Off and Both Lower-Side FETs to Ground in the H Bridge are Switched at the Same Time With the Duty Cycle Proportional to the Battery Charge Current

3 Comparison of Low-Frequency vs. High-Frequency Inverter

There are two simple ways to accomplish the inversion from the energy stored inside the battery or taken from the Solar Panel to the AC power supply capable of running common loads. The prevalent topology has been referred to as the Sine Wave topology by leading manufacturers or *technically* low-frequency inverter (LF Inverter). The inversion happens as shown below:

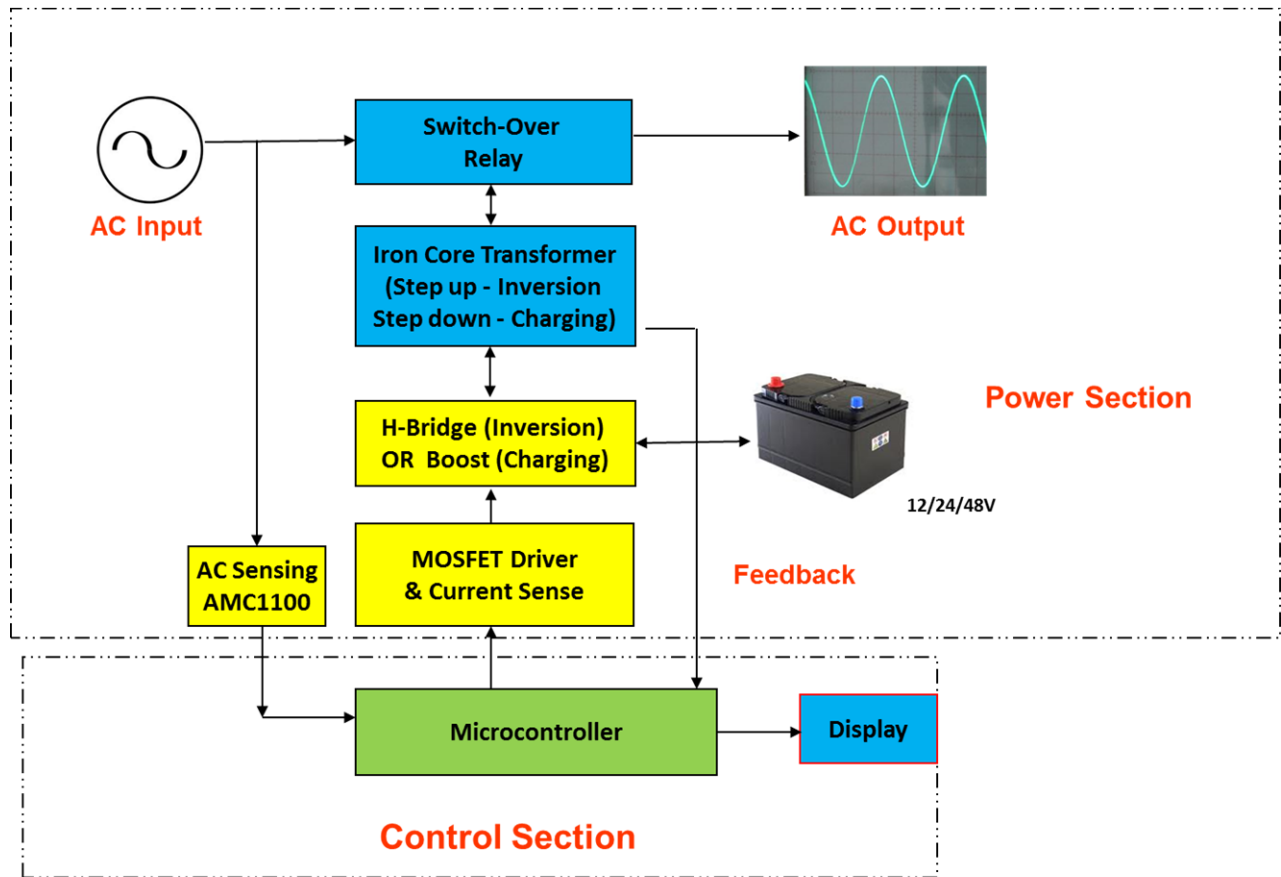
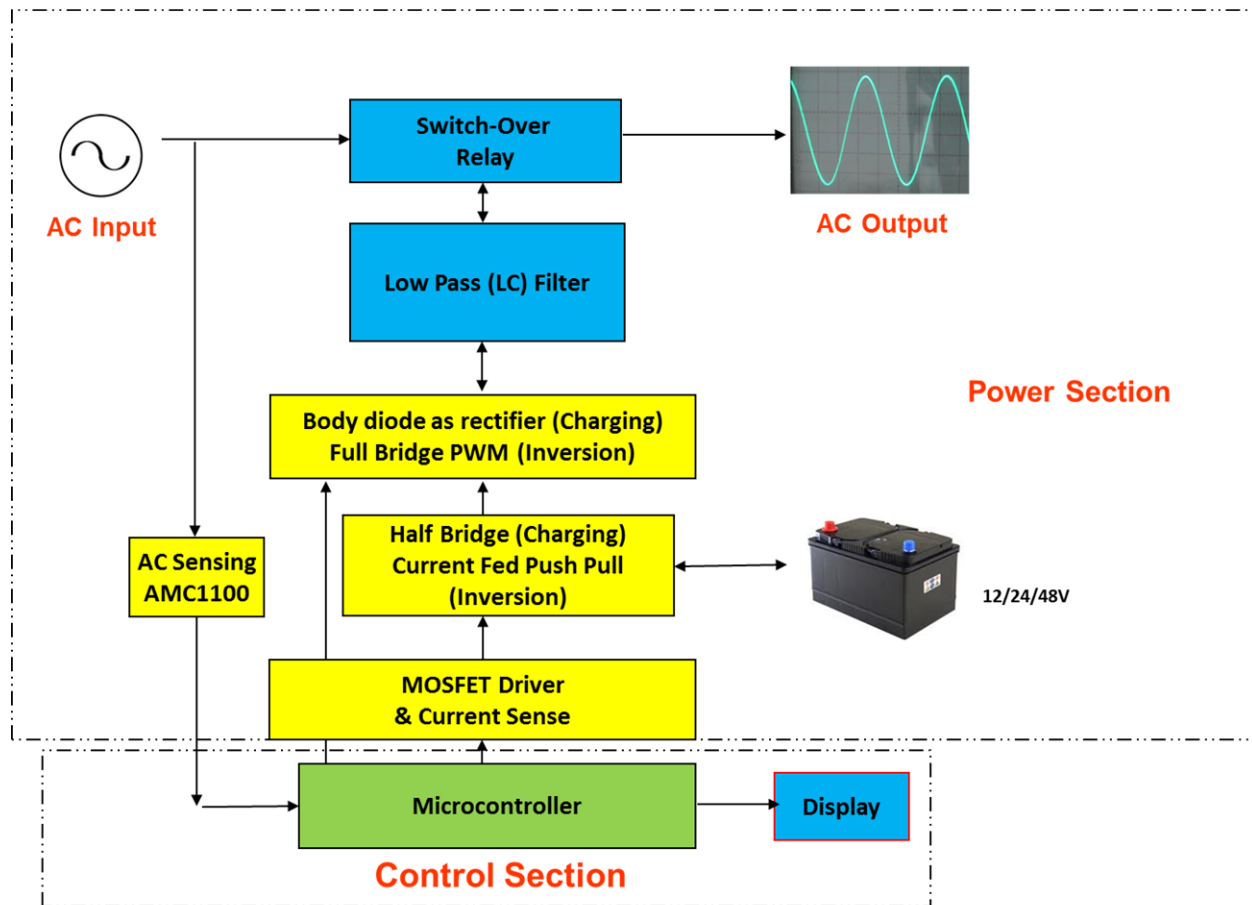

Figure 31. Bidirectional Low Frequency Inverter

In the LF inverter, the battery voltage is first chopped with the full bridge (using high-frequency PWM, generally 3 kHz to 20 kHz) to an AC waveform. The iron core transformer then boosts the 12-V chopped waveform to 220-V RMS output waveform at 50 Hz. At the output of the transformer, a capacitor helps filter the waveform to make a clean 50-Hz AC Sine Wave. Although this inversion method is widespread today, the iron core transformer is quite bulky and increases the cost of the overall solution. The LF inverters use SM72295 – a highly integrated gate driver with two high-side, current-sensing amplifiers – AMC1100 for AC mains current sensing, along with the LM5017 or TPS54231 for the power supply section.

Figure 32. Bidirectional High-Frequency Inverter

The next advancement in inversion technology is the use of high frequency inverters, or *HF* inverters. This technology involves more processing complexity but can significantly increase overall system efficiency and eliminate the use of the bulky iron core transformer. In a high-frequency inverter, the battery voltage is converted to an intermediate high DC voltage before it's converted to an AC waveform using Pulse Width modulation. Here, we demonstrate an example implementation using current fed push-pull topology. During the inverter stage (when the AC mains is not present), the push-pull stage converts the battery voltage to a high voltage in the range of 350 V, which is then chopped with the help of full bridge PWM driven by a microcontroller to form 220-V AC. During the charging stage, the AC main is rectified using the body diodes in the full bridge stage and the second stage acts as half bridge. Thus, bidirectional control is achieved without the need of any additional components.

Although the HF inverter is much higher efficiency than LF inverter, this technology is not very popular for two reasons. First, the use of push-pull stage presents some challenges in the form of voltage overshoots on the MOSFETs, making practice implementation difficult. The possible techniques to solve these issues are passive and active clamping. The passive clamping solves the problem however they lead to higher power dissipation. We employ active clamping in our designs with the help of which we can achieve zero voltage switching (ZVS).

The second challenge is more towards the adoption of this new technology. We see a need of consumer awareness on newer technologies. The implementation of standards, for example STAR rating, in inverters as in other appliances will help. The HF inverter is significantly lighter in weight than its counterpart – LF inverter. The unique challenge most sellers face is that people don't think they are getting full bang for their buck when they pay for the lighter much-improved design.

Revision History

NOTE: Page numbers for previous revisions may differ from page numbers in the current version.

Changes from Original (June 2013) to A Revision	Page
• Added <i>Comparison of Low-Frequency vs. High-Frequency Inverter</i> section	28

IMPORTANT NOTICE FOR TI DESIGN INFORMATION AND RESOURCES

Texas Instruments Incorporated ("TI") technical, application or other design advice, services or information, including, but not limited to, reference designs and materials relating to evaluation modules, (collectively, "TI Resources") are intended to assist designers who are developing applications that incorporate TI products; by downloading, accessing or using any particular TI Resource in any way, you (individually or, if you are acting on behalf of a company, your company) agree to use it solely for this purpose and subject to the terms of this Notice.

TI's provision of TI Resources does not expand or otherwise alter TI's applicable published warranties or warranty disclaimers for TI products, and no additional obligations or liabilities arise from TI providing such TI Resources. TI reserves the right to make corrections, enhancements, improvements and other changes to its TI Resources.

You understand and agree that you remain responsible for using your independent analysis, evaluation and judgment in designing your applications and that you have full and exclusive responsibility to assure the safety of your applications and compliance of your applications (and of all TI products used in or for your applications) with all applicable regulations, laws and other applicable requirements. You represent that, with respect to your applications, you have all the necessary expertise to create and implement safeguards that (1) anticipate dangerous consequences of failures, (2) monitor failures and their consequences, and (3) lessen the likelihood of failures that might cause harm and take appropriate actions. You agree that prior to using or distributing any applications that include TI products, you will thoroughly test such applications and the functionality of such TI products as used in such applications. TI has not conducted any testing other than that specifically described in the published documentation for a particular TI Resource.

You are authorized to use, copy and modify any individual TI Resource only in connection with the development of applications that include the TI product(s) identified in such TI Resource. NO OTHER LICENSE, EXPRESS OR IMPLIED, BY ESTOPPEL OR OTHERWISE TO ANY OTHER TI INTELLECTUAL PROPERTY RIGHT, AND NO LICENSE TO ANY TECHNOLOGY OR INTELLECTUAL PROPERTY RIGHT OF TI OR ANY THIRD PARTY IS GRANTED HEREIN, including but not limited to any patent right, copyright, mask work right, or other intellectual property right relating to any combination, machine, or process in which TI products or services are used. Information regarding or referencing third-party products or services does not constitute a license to use such products or services, or a warranty or endorsement thereof. Use of TI Resources may require a license from a third party under the patents or other intellectual property of the third party, or a license from TI under the patents or other intellectual property of TI.

TI RESOURCES ARE PROVIDED "AS IS" AND WITH ALL FAULTS. TI DISCLAIMS ALL OTHER WARRANTIES OR REPRESENTATIONS, EXPRESS OR IMPLIED, REGARDING TI RESOURCES OR USE THEREOF, INCLUDING BUT NOT LIMITED TO ACCURACY OR COMPLETENESS, TITLE, ANY EPIDEMIC FAILURE WARRANTY AND ANY IMPLIED WARRANTIES OF MERCHANTABILITY, FITNESS FOR A PARTICULAR PURPOSE, AND NON-INFRINGEMENT OF ANY THIRD PARTY INTELLECTUAL PROPERTY RIGHTS.

TI SHALL NOT BE LIABLE FOR AND SHALL NOT DEFEND OR INDEMNIFY YOU AGAINST ANY CLAIM, INCLUDING BUT NOT LIMITED TO ANY INFRINGEMENT CLAIM THAT RELATES TO OR IS BASED ON ANY COMBINATION OF PRODUCTS EVEN IF DESCRIBED IN TI RESOURCES OR OTHERWISE. IN NO EVENT SHALL TI BE LIABLE FOR ANY ACTUAL, DIRECT, SPECIAL, COLLATERAL, INDIRECT, PUNITIVE, INCIDENTAL, CONSEQUENTIAL OR EXEMPLARY DAMAGES IN CONNECTION WITH OR ARISING OUT OF TI RESOURCES OR USE THEREOF, AND REGARDLESS OF WHETHER TI HAS BEEN ADVISED OF THE POSSIBILITY OF SUCH DAMAGES.

You agree to fully indemnify TI and its representatives against any damages, costs, losses, and/or liabilities arising out of your non-compliance with the terms and provisions of this Notice.

This Notice applies to TI Resources. Additional terms apply to the use and purchase of certain types of materials, TI products and services. These include; without limitation, TI's standard terms for semiconductor products (<http://www.ti.com/sc/docs/stdterms.htm>), [evaluation modules](#), and [samples](http://www.ti.com/sc/docs/sampterm.htm) (<http://www.ti.com/sc/docs/sampterm.htm>).

Mailing Address: Texas Instruments, Post Office Box 655303, Dallas, Texas 75265
Copyright © 2018, Texas Instruments Incorporated