

# TPS1HC30-Q1, 30-m $\Omega$ , 5-A, Single-Channel Automotive Smart High Side Switch

## 1 Features

- Single-channel, smart automotive, high side power switch with full diagnostics
  - Open-drain status output
  - Current sense analog output
- Wide operating voltage 3 V to 28 V
- Low standby current, 2.5  $\mu$ A at 85°C
- Operating junction temperature, –40 to 150°C
- 1.8-V, 3.3-V and 5-V logic compatible
- Fault sense voltage scaling for ADC protection
- Programmable current limit and accuracy  $\pm$ 15% at 3.5 A
- High-accuracy current sense,  $\pm$ 6% at 1 A
- Protection
  - Overload and short-circuit protection
  - Inductive load negative voltage clamp
  - Undervoltage Lockout (UVLO) protection
  - Thermal shutdown and swing with self recovery
  - Loss of GND, loss of supply protection
  - Reverse battery protection
- Diagnostic
  - On- and Off-state output open-load and short-to-battery detection
  - Overload and short to ground detection
  - Thermal shutdown and swing detection
- Qualifications
  - AEC-Q100 automotive qualified for automotive applications
    - Temperature grade 1: –40°C to +125°C,  $T_A$
  - Tested according to AECQ100-12 Grade A, 1 million times short to GND test
  - Electrical transient disturbance immunity certification of ISO7637-2 and ISO16750-2
- 14-pin, thermally-enhanced PWP package

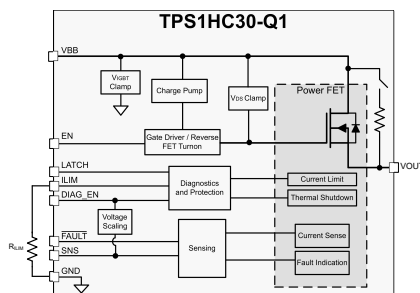

**Functional Block Diagram**

## 2 Applications

- [Automotive display module](#)
- [ADAS modules](#)
- [Seat comfort module](#)
- [HVAC control module](#)
- [Body control module](#)

## 3 Description

The TPS1HC30-Q1 device is a fully protected, high-side power switch with integrated NMOS power FET and charge pump, targeted for the intelligent control of the variable kinds of loads. Accurate current sense and programmable current limit features differentiate the device from the market.

Low-logic, high-threshold,  $V_{IH}$ , of 1.5 V on the input pins allow use of MCUs down to 1.8 V. High-accuracy current sensing allows a better real-time monitoring effect and more accurate diagnostics without further calibration. The external high-accuracy current limit allows setting the current limit value by application. The device highly improves the reliability of the system by clamping the inrush current effectively under start-up or short-circuit conditions. The TPS1HC30-Q1 device can be used as a high-side power switch for a wide variety of resistive, inductive, and capacitive loads, including the low-wattage bulbs, LEDs, relays, solenoids, and heaters.

### Package Information<sup>(1)</sup>

PART NUMBER	PACKAGE	BODY SIZE (NOM)
TPS1HC30-Q1	PWP (HTSSOP, 14)	4.40 mm × 5.00 mm

- (1) For all available packages, see the orderable addendum at the end of the data sheet.

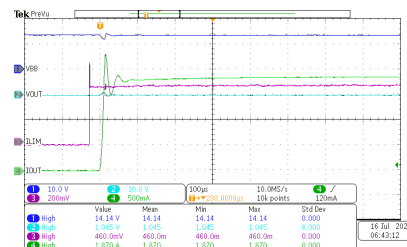

**Current Limit Application**



## Table of Contents

<b>1 Features</b> .....	1	8.2 Functional Block Diagram.....	14
<b>2 Applications</b> .....	1	8.3 Feature Description.....	14
<b>3 Description</b> .....	1	8.4 Device Functional Modes.....	31
<b>4 Revision History</b> .....	2	<b>9 Application and Implementation</b> .....	33
<b>5 Pin Configuration and Functions</b> .....	3	9.1 Application Information.....	33
5.1 Recommended Connections for Unused Pins.....	4	9.2 Typical Application.....	33
<b>6 Specifications</b> .....	5	9.3 Power Supply Recommendations.....	37
6.1 Absolute Maximum Ratings.....	5	9.4 Layout.....	38
6.2 ESD Ratings.....	5	<b>10 Device and Documentation Support</b> .....	40
6.3 Recommended Operating Conditions.....	5	10.1 Documentation Support.....	40
6.4 Thermal Information.....	6	10.2 Receiving Notification of Documentation Updates.....	40
6.5 Electrical Characteristics.....	6	10.3 Support Resources.....	40
6.6 SNS Timing Characteristics.....	9	10.4 Trademarks.....	40
6.7 Switching Characteristics.....	9	10.5 Electrostatic Discharge Caution.....	40
<b>7 Parameter Measurement Information</b> .....	11	10.6 Glossary.....	40
<b>8 Detailed Description</b> .....	13	<b>11 Mechanical, Packaging, and Orderable Information</b> .....	40
8.1 Overview.....	13		

## 4 Revision History

NOTE: Page numbers for previous revisions may differ from page numbers in the current version.

DATE	REVISION	NOTES
July 2022	*	Initial Release

## 5 Pin Configuration and Functions

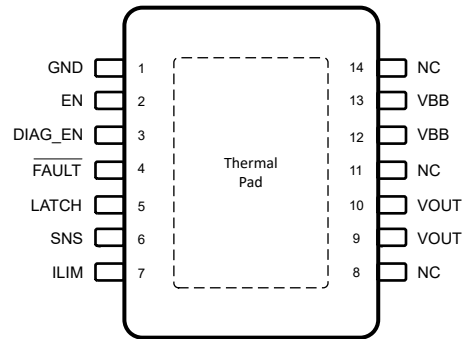

**Figure 5-1. PWP Package 14-Pin HTSSOP Top View**

**Table 5-1. Pin Functions**

over operating free-air temperature range (unless otherwise noted)

PIN		TYPE	DESCRIPTION
NO.	NAME		
1	GND	Power	Ground of device. Connect to resistor-diode ground network to have reverse battery protection.
2	EN	I	Input control for channel activation
3	DIAG_EN	I	Enable-disable pin for diagnostics, internal pulldown
4	FAULT	O	Open-drain global fault output. Referred to FAULT, FLT, or fault pin.
5	LATCH	I	Thermal shutdown behavior, latch-off or auto-retry, internal pulldown
6	SNS	O	Output corresponding sense value based on sense ratio
7	ILIM	O	Adjustable current limit. Short to ground or leave floating if external current limit is not used.
8, 11, 14	NC	N/A	No internal connection
9, 10	VOUT	Power	Output of high-side switch, connected to load
12, 13	VBB	Power	Power supply
Thermal Pad	Pad	—	Thermal Pad, internally shorted to ground

## 5.1 Recommended Connections for Unused Pins

The TPS1HC30-Q1 is designed to provide an enhanced set of diagnostic and protection features. However, if the system design only allows for a limited number of I/O connections, some pins can be considered as optional.

**Table 5-2. Connections For Optional Pins**

PIN NAME	CONNECTION IF NOT USED	IMPACT IF NOT USED
SNS	Ground through 1-kΩ resistor	Analog sense is not available.
LATCH	Float or ground through R <sub>PROT</sub> resistor	With LATCH unused, the device auto-retries after a fault. If latched behavior is desired, but the system describes limited I/O, it is possible to use one microcontroller output to control the latch function of several high side channels.
ILIM	Float	If the ILIM pin is left floating, the device is set to the default internal current-limit threshold. This impact is considered a fault state for the device.
DIA_EN	Float or ground through R <sub>PROT</sub> resistor	With DIA_EN unused, the analog sense, open-load, and short-to-battery diagnostics are not available.

## 6 Specifications

### 6.1 Absolute Maximum Ratings

Over operating free-air temperature range (unless otherwise noted)<sup>(1)</sup>

		MIN	MAX	UNIT
Maximum continuous supply voltage, $V_{BB}$			28	V
Load dump voltage, $V_{LD}$	ISO16750-2:2010(E)		35	V
Reverse Polarity Voltage	Maximum duration of 3 minutes and with the application circuit	-18		V
Enable pin current, $I_{EN}$	Enable pin current, $I_{EN}$	-1	20	mA
Enable pin voltage, $V_{EN}$		-1	7	V
Diagnostic Enable pin current, $I_{DIA\_EN}$		-1	20	mA
Diagnostic Enable pin voltage, $V_{DIA\_EN}$		-1	7	V
Sense pin current, $I_{SNS}$		-100	10	mA
Sense pin voltage, $V_{SNS}$		-1	5.5	V
Latch pin current, $I_{LATCH}$		-1	10	mA
Latch pin voltage, $V_{LATCH}$		-1	7	V
FLT pin current, $I_{FLT}$		-30	10	mA
FLT pin voltage, $V_{FLT}$		-0.3	7	V
Reverse ground current, $I_{GND}$	$V_{BB} < 0$ V		-50	mA
Storage temperature, $T_{stg}$		-65	150	°C

- (1) Operation outside the Absolute Maximum Ratings may cause permanent device damage. Absolute Maximum Ratings do not imply functional operation of the device at these or any other conditions beyond those listed under Recommended Operating Conditions. If used outside the Recommended Operating Conditions but within the Absolute Maximum Ratings, the device may not be fully functional, and this may affect device reliability, functionality, performance, and shorten the device lifetime.

### 6.2 ESD Ratings

			VALUE	UNIT
$V_{(ESD)}$	Electrostatic discharge <sup>(1)</sup>	Human-body model (HBM), per AEC Q100-002 Classification Level 2 <sup>(2)</sup>	All pins except VS and VOUT	±2000
			VS and VOUT	±4000
		Charged-device model (CDM), per AEC Q100-011 Classification Level C5	All pins	±750

- (1) All ESD strikes are with reference from the pin mentioned to GND  
(2) AEC-Q100-002 indicates that HBM stressing shall be in accordance with the ANSI/ESDA/JEDEC JS-001 specifications.

### 6.3 Recommended Operating Conditions

over operating free-air temperature range (unless otherwise noted)<sup>(1)</sup>

		MIN	MAX	UNIT
$V_{VBB\_NOM}$	Nominal supply voltage <sup>(1)</sup>	3.5	18	V
$V_{VBB\_EXT}$	Extended supply voltage <sup>(2)</sup>	2.6	28	V
$V_{VBB\_SC}$	Short circuit supply voltage capability		28	V
$V_{EN}$	Enable voltage	-1	5.5	V
$V_{DIA\_EN}$	Diagnostic Enable voltage	-1	5.5	V
$V_{LATCH}$	Latch voltage	-1	5.5	V
$V_{SNS}$	Sense voltage	-1	7	V
$T_A$	Operating free-air temperature	-40	125	°C

- (1) All operating voltage conditions are measured with respect to device GND  
(2) Device will function within extended operating range, however some parametric values might not apply.

## 6.4 Thermal Information

THERMAL METRIC <sup>(1) (2)</sup>		TPS1HC30-Q1	UNIT
		PWP (HTSSOP)	
		14 PINS	
$R_{\theta JA}$	Junction-to-ambient thermal resistance	44.2	°C/W
$R_{\theta JC(top)}$	Junction-to-case (top) thermal resistance	33.8	°C/W
$R_{\theta JB}$	Junction-to-board thermal resistance	19.2	°C/W
$\Psi_{JT}$	Junction-to-top characterization parameter	1.4	°C/W
$\Psi_{JB}$	Junction-to-board characterization parameter	19.2	°C/W
$R_{\theta JC(bot)}$	Junction-to-case (bottom) thermal resistance	5.0	°C/W

- (1) For more information about traditional and new thermal metrics, see the [SPRA953](#) application report.  
 (2) The thermal parameters are based on a 4-layer PCB according to the JESD51-5 and JESD51-7 standards.

## 6.5 Electrical Characteristics

$V_{BB} = 6\text{ V to }18\text{ V}$ ,  $T_A = -40^\circ\text{C to }125^\circ\text{C}$  (unless otherwise noted); Typical application is 13.5V, 10 $\Omega$ , RILIM=Open (unless otherwise specified)

PARAMETER		TEST CONDITIONS		MIN	TYP	MAX	UNIT
<b>INPUT VOLTAGE AND CURRENT</b>							
$V_{Clamp}$	VDS clamp voltage	$T_J = 25^\circ\text{C}$		35		43	V
		$T_J = -40^\circ\text{C to }150^\circ\text{C}$		33		45	V
$V_{UVLOR}$	$V_{BB}$ undervoltage lockout rising	Measured with respect to the GND pin of the device		3.0	3.5	4.0	V
$V_{UVLOF}$	$V_{BB}$ undervoltage lockout falling			2.4	2.6	3.0	V
$I_{SB}$	Standby current (total device leakage including MOSFET channel)	$V_{BB} \leq 18\text{ V}$ , $V_{EN} = V_{DIA\_EN} = 0\text{ V}$ , $V_{OUT} = 0\text{ V}$	$T_J = 25^\circ\text{C}$			0.3	$\mu\text{A}$
			$T_J = 85^\circ\text{C}$			2.5	$\mu\text{A}$
$I_{L\_NOM}$	Continuous load current	Channel enabled, $T_{AMB} = 85^\circ\text{C}$			4.5		A
$I_{OUT(standby)}$	Output leakage current	$V_{BB} \leq 18\text{ V}$ , $T_J = 25^\circ\text{C}$ $V_{EN} = V_{DIA\_EN} = 0\text{ V}$ , $V_{OUT} = 0\text{ V}$			0.01	0.3	$\mu\text{A}$
		$V_{BB} \leq 18\text{ V}$ , $T_J = 85^\circ\text{C}$ $V_{EN} = V_{DIA\_EN} = 0\text{ V}$ , $V_{OUT} = 0\text{ V}$				2.5	$\mu\text{A}$
$I_{DIA}$	Current consumption in diagnostic mode	$V_{BB} \leq 18\text{ V}$ , $I_{SNS} = 0\text{ mA}$ $V_{EN} = 0\text{ V}$ , $V_{DIA\_EN} = 5\text{ V}$ , $V_{OUT} = 0\text{ V}$			1.3	3	mA
$I_Q$	Quiescent current channel enabled	$V_{BB} \leq 28\text{ V}$ $V_{EN} = V_{DIA\_EN} = 5\text{ V}$ , $I_{OUTx} = 0\text{ A}$			1.6	3	mA
$t_{STBY}$	Standby mode delay time	$V_{ENx} = V_{DIA\_EN} = 0\text{ V}$ to standby			20		ms
<b>RON CHARACTERISTICS</b>							
$R_{ON}$	On-resistance (Includes MOSFET channel and metallization on die)	$6\text{ V} \leq V_{BB} \leq 28\text{ V}$ , $I_{OUT} = 1\text{ A}$	$T_J = 25^\circ\text{C}$		30		m $\Omega$
			$T_J = 150^\circ\text{C}$			57	m $\Omega$
		$3\text{ V} \leq V_{BB} \leq 6\text{ V}$ , $I_{OUT} = 1\text{ A}$	$T_J = 25^\circ\text{C}$			57	m $\Omega$
			$T_J = 150^\circ\text{C}$			75	m $\Omega$
$R_{ON(REV)}$	On-resistance during reverse polarity	$-18\text{ V} \leq V_{BB} \leq -6\text{ V}$		$T_J = 25^\circ\text{C}$		30	m $\Omega$
				$T_J = 105^\circ\text{C}$			48
<b>CURRENT SENSE CHARACTERISTICS</b>							
$K_{SNS}$	Current sense ratio $I_{OUT} / I_{SNS}$	$I_{OUT} = 1.5\text{ A}$			1814		

## 6.5 Electrical Characteristics (continued)

$V_{BB} = 6\text{ V to }18\text{ V}$ ,  $T_A = -40^\circ\text{C to }125^\circ\text{C}$  (unless otherwise noted); Typical application is 13.5V, 10Ω, RILIM=Open (unless otherwise specified)

PARAMETER		TEST CONDITIONS		MIN	TYP	MAX	UNIT	
$I_{SNSI}$	Current sense current and accuracy	$V_{EN} = V_{DIA\_EN} = 5\text{ V}$	$I_{OUT} = 6\text{ A}$		3.8		mA	
					-3		3	%
			$I_{OUT} = 3\text{ A}$		1.92		4	mA
					-4		4	%
			$I_{OUT} = 1.5\text{ A}$		0.96		4	mA
					-4		4	%
			$I_{OUT} = 750\text{ mA}$		0.48		6	mA
					-6		6	%
			$I_{OUT} = 300\text{ mA}$		0.192		10	mA
					-10		10	%
$I_{OUT} = 150\text{ mA}$		0.096		15	mA			
		-15		15	%			
$I_{OUT} = 75\text{ mA}$		0.0481		25	mA			
		-25		25	%			
$I_{OUT} = 30\text{ mA}$		0.0192		40	mA			
		-40		40	%			
$I_{OUT} = 15\text{ mA}$		0.0096		60	mA			
		-60		60	%			
$I_{OUT} = 7.5\text{ mA}$		0.0048		75	mA			
		-75		75	%			
<b>SNS CHARACTERISTICS</b>								
$V_{SNSFH}$	$V_{SNS}$ fault high-level	$V_{DIA\_EN} = 5\text{ V}$		4.2	5	5.77	V	
		$V_{DIA\_EN} = V_{IH}$ to 3.3 V		3.0	3.3	3.82	V	
$I_{SNSFH}$	$I_{SNS}$ fault high-level	$V_{DIA\_EN} > V_{IH,DIAG\_EN}$			6.6		mA	
$V_{BB\_ISNS}$	$V_{BB}$ headroom needed for full current sense and fault functionality	$V_{DIAG\_EN} = 3.3\text{ V}$		5.3			V	
$V_{BB\_ISNS}$	$V_{BB}$ headroom needed for full current sense and fault functionality	$V_{DIAG\_EN} = 5\text{ V}$		6.5			V	
<b>CURRENT LIMIT CHARACTERISTICS</b>								
$I_{CL\_LINPK}$	Linear Mode peak	$T_J = -40^\circ\text{C to }150^\circ\text{C}$ dI/dt < 0.01 A/ms	$I_{LIM} = 0.7\text{ A to }7\text{ A}$	$0.95 \times I_{CL}$		$1.2 \times I_{CL}$	A	
$I_{CL\_ENPS}$	Peak current enabling into permanent short	$T_J = -40^\circ\text{C to }150^\circ\text{C}$	$R_{LIM} = 7.15\text{ k}\Omega$ to 71.5 kΩ			$2 \times I_{CL}$	A	
$I_{OVCR}$	OVCR Peak current threshold when short is applied while switch enabled	$T_J = -40^\circ\text{C to }150^\circ\text{C}$	$R_{LIM} \geq 35\text{ k}\Omega$			15	A	
			$15\text{ k}\Omega \leq R_{LIM} < 35\text{ k}\Omega$			23	A	
			$R_{LIM} < 15\text{ k}\Omega$			33	A	
$I_{CL}$	$I_{CL}$ Current Limit Threshold	$T_J = -40^\circ\text{C to }150^\circ\text{C}$	$R_{LIM} = \text{GND}$	9.1	13	16.9	A	
			$R_{LIM} = \text{open, or out of range}$	3.85	5.5	7.15	A	

## 6.5 Electrical Characteristics (continued)

$V_{BB} = 6\text{ V to }18\text{ V}$ ,  $T_A = -40^\circ\text{C to }125^\circ\text{C}$  (unless otherwise noted); Typical application is 13.5V, 10 $\Omega$ , RILIM=Open (unless otherwise specified)

PARAMETER		TEST CONDITIONS		MIN	TYP	MAX	UNIT
K <sub>CL</sub>	Current Limit Ratio	T <sub>J</sub> = -40°C to 150°C	R <sub>ILIM</sub> = 7.15 k $\Omega$	-20%	87.5	+20%	A * k $\Omega$
			R <sub>ILIM</sub> = 25 k $\Omega$	-10%	90	+10%	A * k $\Omega$
			R <sub>ILIM</sub> = 71.5 k $\Omega$	-20%	91.8	+20%	A * k $\Omega$
<b>FAULT CHARACTERISTICS</b>							
R <sub>VOL</sub>	Open-load (OL) detection internal pull-up resistor	V <sub>EN</sub> = 0 V, V <sub>DIA_EN</sub> = 5 V			150		k $\Omega$
t <sub>OL</sub>	Open-load (OL) detection deglitch time	V <sub>EN</sub> = 0 V, V <sub>DIA_EN</sub> = 5 V, When V <sub>BB</sub> - V <sub>OUT</sub> < V <sub>OL</sub> , duration longer than t <sub>OL</sub> . Openload detected.			400	1000	$\mu$ s
V <sub>OL</sub>	Open-load (OL) detection voltage	V <sub>EN</sub> = 0 V, V <sub>DIA_EN</sub> = 5 V		1.5	2	2.5	V
V <sub>FLT</sub>	FLT low output voltage	I <sub>FLT</sub> = 2.5 mA				0.5	V
t <sub>OL1</sub>	OL and STB indication-time from EN falling	V <sub>EN</sub> = 5 V to 0 V, V <sub>DIA_EN</sub> = 5 V I <sub>OUT</sub> = 0 mA, V <sub>OUT</sub> = V <sub>BB</sub> - V <sub>OL</sub>			500	1000	$\mu$ s
t <sub>OL2</sub>	OL and STB indication-time from DIA_EN rising	V <sub>EN</sub> = 0 V, V <sub>DIA_EN</sub> = 0 V to 5 V I <sub>OUT</sub> = 0 mA, V <sub>OUT</sub> = V <sub>BB</sub> - V <sub>OL</sub>				1000	$\mu$ s
T <sub>ABS</sub>	Thermal shutdown				165		°C
T <sub>REL</sub>	Relative thermal shutdown				85		°C
T <sub>HYS</sub>	Thermal shutdown hysteresis				25		°C
t <sub>FAULT_FLT</sub>	Fault indication-time	V <sub>DIA_EN</sub> = 5 V Time between fault and $\overline{\text{FLT}}$ asserting				60	$\mu$ s
t <sub>FAULT_SNS</sub>	Fault indication-time	V <sub>DIA_EN</sub> = 5 V Time between fault and I <sub>SNS</sub> settling at V <sub>SNSFH</sub>				60	$\mu$ s
t <sub>RETRY</sub>	Retry time	Time from fault shutdown until switch re-enable (thermal shutdown).		1	2	3	ms
<b>EN PIN CHARACTERISTICS</b>							
V <sub>IL_EN</sub>	Input voltage low-level	No GND Network				0.8	V
V <sub>IH_EN</sub>	Input voltage high-level	No GND Network		1.5			V
V <sub>IHYS_EN</sub>	Input voltage hysteresis				280		mV
R <sub>EN</sub>	Internal pulldown resistor			200	350	500	k $\Omega$
I <sub>IL_EN</sub>	Input current low-level	V <sub>EN</sub> = 0.8 V			2.2		$\mu$ A
I <sub>IH_EN</sub>	Input current high-level	V <sub>EN</sub> = 5 V			14		$\mu$ A
<b>DIA_EN PIN CHARACTERISTICS</b>							
V <sub>IL_DIA_EN</sub>	Input voltage low-level	No GND Network				0.8	V
V <sub>IH_DIA_EN</sub>	Input voltage high-level	No GND Network		1.5			V
V <sub>IHYS_DIA_EN</sub>	Input voltage hysteresis				280		mV
R <sub>DIA_EN</sub>	Internal pulldown resistor			100	250	500	k $\Omega$
I <sub>IL_DIA_EN</sub>	Input current low-level	V <sub>DIA_EN</sub> = 0.8 V			2.2		$\mu$ A
I <sub>IH_DIA_EN</sub>	Input current high-level	V <sub>DIA_EN</sub> = 5 V			14		$\mu$ A
<b>LATCH PIN Characteristics</b>							
V <sub>IL_LATCH</sub>	Input voltage low-level	No GND Network				0.8	V
V <sub>IH_LATCH</sub>	Input voltage high-level	No GND Network		1.5			V



## 6.5 Electrical Characteristics (continued)

$V_{BB} = 6\text{ V to }18\text{ V}$ ,  $T_A = -40^\circ\text{C to }125^\circ\text{C}$  (unless otherwise noted); Typical application is 13.5V, 10 $\Omega$ , RILIM=Open (unless otherwise specified)

PARAMETER		TEST CONDITIONS	MIN	TYP	MAX	UNIT
$V_{IHYS, LATCH}$	Input voltage hysteresis			280		mV
$R_{LATCH}$	Internal pulldown resistor		0.7	1	1.3	M $\Omega$
$I_{IL, LATCH}$	Input current low-level	$V_{DIA\_EN} = 0.8\text{ V}$		2.2		$\mu\text{A}$
$I_{IH, LATCH}$	Input current high-level	$V_{DIA\_EN} = 5\text{ V}$		14		$\mu\text{A}$

## 6.6 SNS Timing Characteristics

$V_{BB} = 6\text{ V to }18\text{ V}$ ,  $T_J = -40^\circ\text{C to }+150^\circ\text{C}$  (unless otherwise noted)

PARAMETER		TEST CONDITIONS	MIN	TYP	MAX	UNIT
<b>SNS TIMING - CURRENT SENSE</b>						
$t_{SNSION1}$	Settling time from rising edge of DIA_EN 50% of $V_{DIA\_EN}$ to 90% of settled ISNS	$V_{ENx} = 5\text{ V}$ , $V_{DIA\_EN} = 0\text{ V to }5\text{ V}$ $R_{SNS} = 1\text{ k}\Omega$ , $I_L = 1\text{ A}$			30	$\mu\text{s}$
$t_{SNSION1}$	Settling time from rising edge of DIA_EN 50% of $V_{DIA\_EN}$ to 90% of settled ISNS	$V_{EN} = 5\text{ V}$ , $V_{DIA\_EN} = 0\text{ V to }5\text{ V}$ $R_{SNS} = 1\text{ k}\Omega$ , $I_L = 30\text{ mA}$			30	$\mu\text{s}$
$t_{SNSION2}$	Settling time from rising edge of EN and DIA_EN 50% of $V_{DIA\_EN}$ $V_{EN}$ to 90% of settled ISNS	$V_{EN} = V_{DIA\_EN} = 0\text{ V to }5\text{ V}$ $V_{BB} = 13.5\text{ V}$ $R_{SNS} = 1\text{ k}\Omega$ , $R_{LOAD} = 10\Omega$			150	$\mu\text{s}$
$t_{SNSION3}$	Settling time from rising edge of EN with DIA_EN HI; 50% of $V_{DIA\_EN}$ $V_{EN}$ to 90% of settled ISNS	$V_{EN} = 0\text{ V to }5\text{ V}$ , $V_{DIA\_EN} = 5\text{ V}$ $V_{BB} = 13.5\text{ V}$ $R_{SNS} = 1\text{ k}\Omega$ , $R_{LOAD} = 10\Omega$			150	$\mu\text{s}$
$t_{SNSIOFF}$	Settling time from falling edge of DIA_EN	$V_{EN} = 5\text{ V}$ , $V_{DIA\_EN} = 5\text{ V to }0\text{ V}$ $V_{BB} = 13.5\text{ V}$ $R_{SNS} = 1\text{ k}\Omega$ , $R_L = 10\Omega$			20	$\mu\text{s}$
$t_{SETTLEH}$	Settling time from rising edge of load step	$V_{EN} = 5\text{ V}$ , $V_{DIA\_EN} = 5\text{ V}$ $R_{SNS} = 1\text{ k}\Omega$ , $I_{OUT} = 0.5\text{ A to }3\text{ A}$			20	$\mu\text{s}$
$t_{SETTLEL}$	Settling time from falling edge of load step	$V_{EN} = 5\text{ V}$ , $V_{DIA\_EN} = 5\text{ V}$ $R_{SNS} = 1\text{ k}\Omega$ , $I_{OUT} = 3\text{ A to }0.5\text{ A}$			20	$\mu\text{s}$

## 6.7 Switching Characteristics

$V_{BB} = 13.5\text{ V}$ ,  $T_J = -40^\circ\text{C to }+150^\circ\text{C}$  (unless otherwise noted)

PARAMETER		TEST CONDITIONS	MIN	TYP	MAX	UNIT
$t_{DR}$	Channel Turn-on delay time (from Standby)	$V_{BB} = 13.5\text{ V}$ , $R_L = 10\Omega$ 50% of EN to 10% of $V_{OUT}$	20	40	55	$\mu\text{s}$
$t_{DR}$	Channel Turn-on delay time (from Active)	$V_{BB} = 13.5\text{ V}$ , $R_L = 10\Omega$ 50% of EN to 10% of $V_{OUT}$	20	35	45	$\mu\text{s}$
$t_{DF}$	Channel Turn-off delay time	$V_{BB} = 13.5\text{ V}$ , $R_L = 10\Omega$ 50% of EN to 90% of $V_{OUT}$	20	30	45	$\mu\text{s}$
$SR_R$	$V_{OUT}$ rising slew rate	$V_{BB} = 13.5\text{ V}$ , 20% to 80% of $V_{OUT}$ , $R_L = 10\Omega$	0.1	0.25	0.5	V/ $\mu\text{s}$
$SR_F$	$V_{OUT}$ falling slew rate	$V_{BB} = 13.5\text{ V}$ , 80% to 20% of $V_{OUT}$ , $R_L = 10\Omega$	0.1	0.25	0.5	V/ $\mu\text{s}$
$f_{max}$	Maximum PWM frequency			0.4	2	kHz
$t_{ON}$	Channel Turn-on time	$V_{BB} = 13.5\text{ V}$ , $R_L = 10\Omega$ 50% of EN to 80% of $V_{OUT}$	30	70	145	$\mu\text{s}$
$t_{OFF}$	Channel Turn-off time	$V_{BB} = 13.5\text{ V}$ , $R_L = 10\Omega$ 50% of EN to 20% of $V_{OUT}$	39	70	145	$\mu\text{s}$

## 6.7 Switching Characteristics (continued)

$V_{BB} = 13.5\text{ V}$ ,  $T_J = -40^\circ\text{C}$  to  $+150^\circ\text{C}$  (unless otherwise noted)

PARAMETER		TEST CONDITIONS	MIN	TYP	MAX	UNIT
$t_{ON} - t_{OFF}$	Turn-on and off matching	1ms enable pulse $V_{BB} = 13.5\text{ V}$ , $R_L = 10\ \Omega$	-40		40	$\mu\text{s}$
		200- $\mu\text{s}$ enable pulse, $V_{BB} = 13.5\text{ V}$ , $R_L = 10\ \Omega$ ,	-40		40	$\mu\text{s}$
$\Delta_{PWM}$	PWM accuracy - average load current	200- $\mu\text{s}$ enable pulse (1ms period), $V_{BB} = 13.5\text{ V}$ , $R_L = 10\ \Omega$	-25		25	%
		$\leq 500\text{Hz}$ , 50% Duty cycle $V_{BB} = 13.5\text{ V}$ , $R_L = 10\ \Omega$	-12		12	%
$E_{ON}$	Switching energy losses during turn-on	$V_{BB} = 13.5\text{ V}$ , $R_L = 10\ \Omega$		0.5		mJ
$E_{OFF}$	Switching energy losses during turn-off	$V_{BB} = 13.5\text{ V}$ , $R_L = 10\ \Omega$		0.5		mJ

ADVANCE INFORMATION

## 7 Parameter Measurement Information

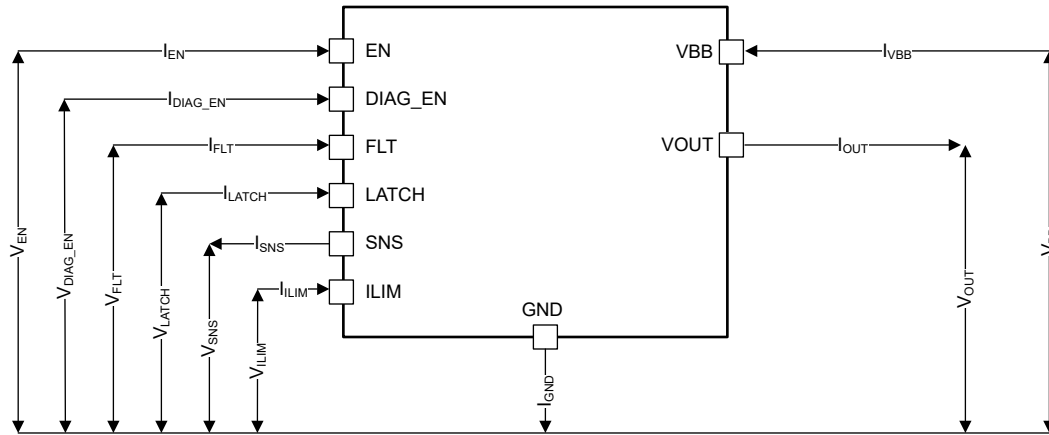

Figure 7-1. Parameter Definitions

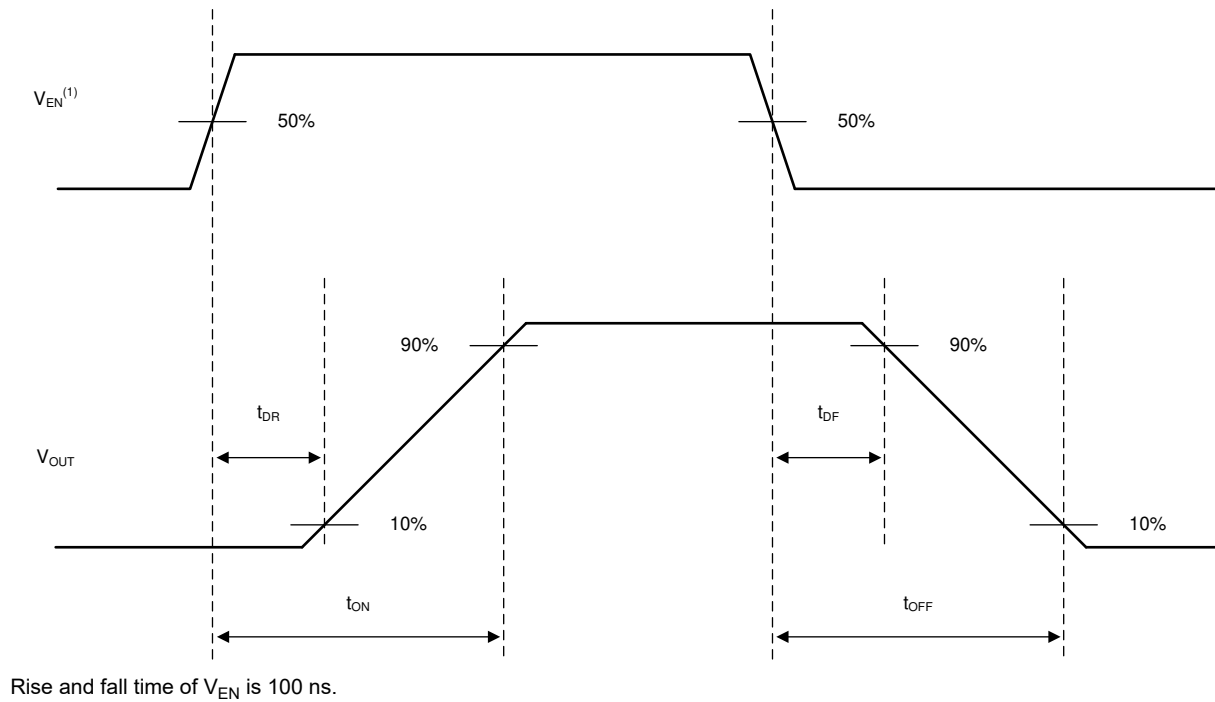
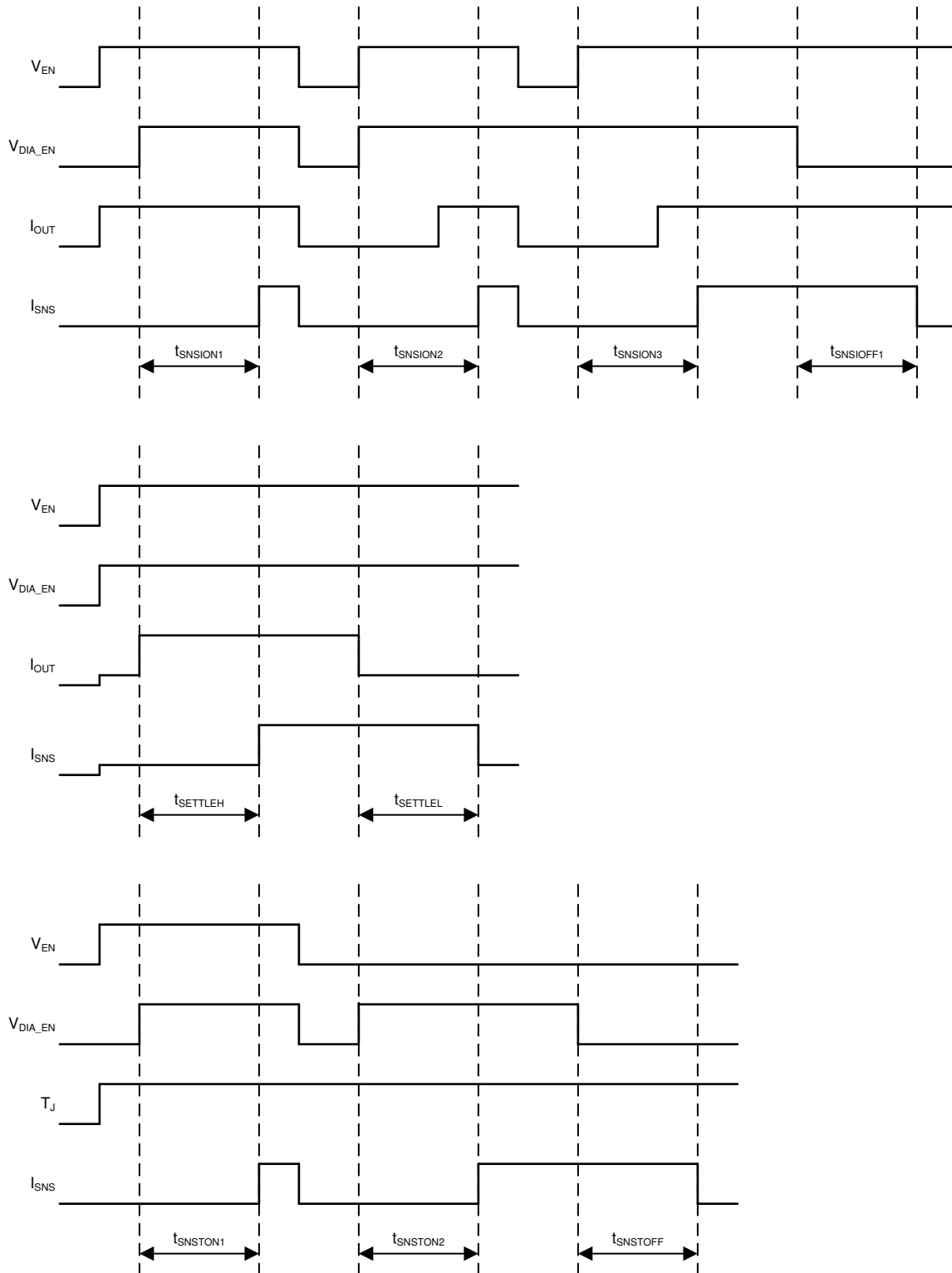

Figure 7-2. Switching Characteristics Definitions



Rise and fall times of control signals are 100 ns. Control signals include: EN, DIA\_EN.

**Figure 7-3. SNS Timing Characteristics Definitions**

## 8 Detailed Description

### 8.1 Overview

The TPS1HC30-Q1 is a single-channel, fully-protected, high side power switch with an integrated NMOS power FET and charge pump. Full diagnostics and high-accuracy current-sense features enable intelligent control of the load. Low logic high threshold,  $V_{IH}$ , of 1.5 V on the input pins allow use of MCUs down to 1.8 V. A programmable current-limit function greatly improves the reliability of the whole system. The device diagnostic reporting has two pins to support both digital status and analog current-sense output, both of which can be set to the high-impedance state when diagnostics are disabled, for multiplexing the MCU analog or digital interface among devices.

The digital status report is implemented with an open-drain structure on the fault pin. When a fault condition occurs, the pin is pulled down to GND. An external pullup is required to match the microcontroller supply level. High-accuracy current sensing allows a better real-time monitoring effect and more-accurate diagnostics without further calibration. A current mirror is used to source  $1 / K_{SNS}$  of the load current, which is reflected as voltage on the SNS pin.  $K_{SNS}$  is a constant value across the temperature and supply voltage. The current-sensing function operates normally within a wide linear region from 0 V to 4 V. The SNS pin can also report a fault by forcing a voltage of  $V_{SNSFH}$  that scales with the diagnostic enable voltage so that the maximum voltage seen by the system ADC is within an acceptable value. This action removes the need for an external Zener diode or resistor divider on the SNS pin.

The external high-accuracy current limit allows setting the current limit value by application. The current limit highly improves the reliability of the system by clamping the inrush current effectively under start-up or short-circuit conditions. Also, the current limit can save system costs by reducing PCB trace, connector size, and the preceding power-stage capacity. An internal current limit is also implemented in this device. The lower value of the external or internal current-limit value is applied.

An active drain and source voltage clamp is built in to address switching off the energy of inductive loads, such as relays, solenoids, pumps, motors, and so forth. During the inductive switching-off cycle, both the energy of the power supply ( $E_{BAT}$ ) and the load ( $E_{LOAD}$ ) are dissipated on the high side power switch itself. With the benefits of process technology and excellent IC layout, the TPS1HC30-Q1 device can achieve excellent power dissipation capacity, which can help save the external free-wheeling circuitry in most cases. For more details, see [Inductive-Load Switching-Off Clamp](#).

Short-circuit reliability is critical for smart high side power-switch devices. The standard of AEC-Q100-012 is to determine the reliability of the devices when operating in a continuous short-circuit condition. Different grade levels are specified according to the pass cycles. This device is qualified with the highest level, Grade A, 1 million times short-to-GND certification.

The TPS1HC30-Q1 device can be used as a high side power switch for a wide variety of resistive, inductive, and capacitive loads, including the low-wattage bulbs, LEDs, relays, solenoids, and heaters.

## 8.2 Functional Block Diagram

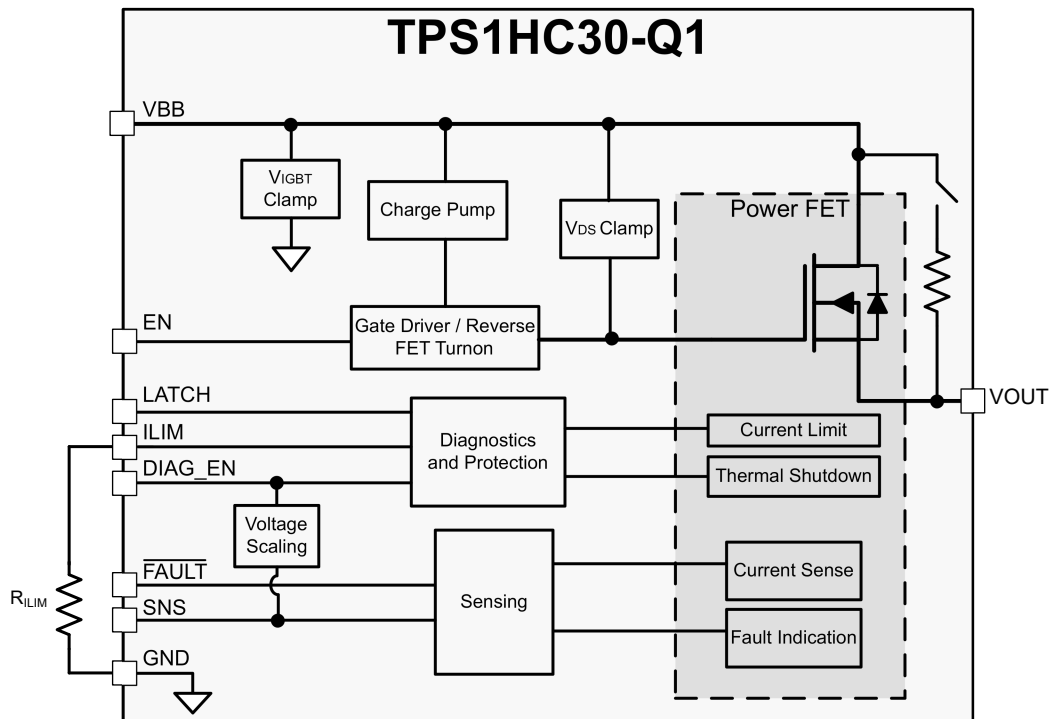

## 8.3 Feature Description

### 8.3.1 Accurate Current Sense

The high-accuracy current-sense function is internally implemented, which allows a better real-time monitoring effect and more-accurate diagnostics without further calibration. A current mirror is used to source  $1 / K_{SNS}$  of the load current, flowing out to the external resistor between the SNS pin and GND, and reflected as voltage on the SNS pin.

$K_{SNS}$  is the ratio of the output current and the sense current. The accuracy values of  $K_{SNS}$  quoted in the electrical characteristics do take into consideration temperature and supply voltage. Each device was internally calibrated while in production, so post-calibration by users is not required in most cases.

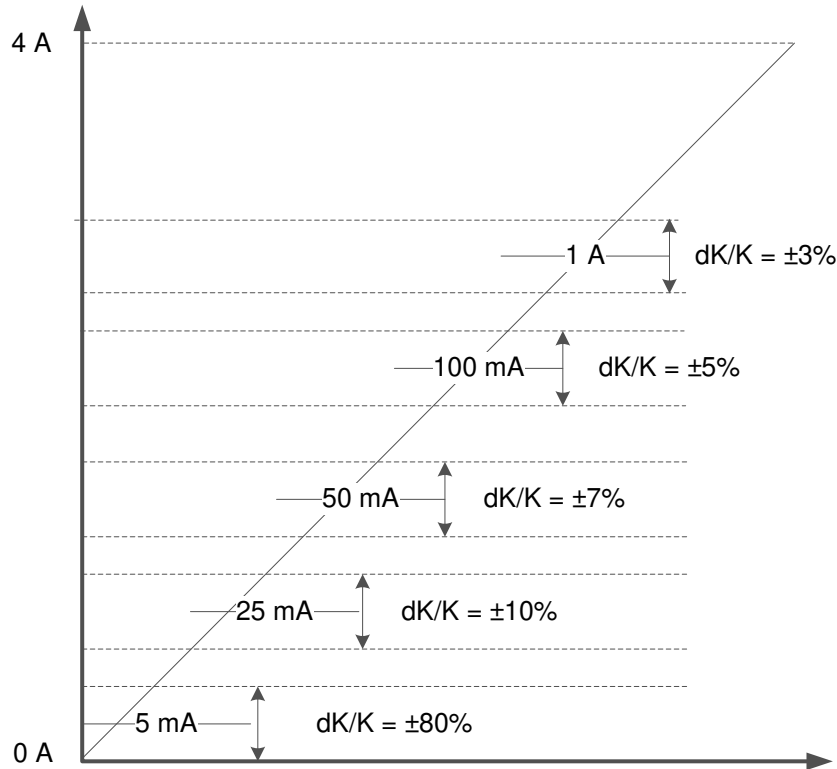
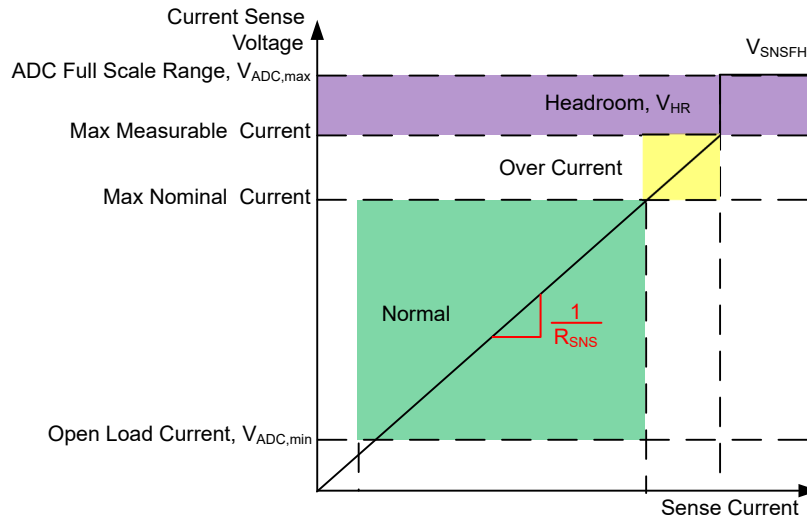

Figure 8-1. Current-Sense Accuracy

The maximum voltage out on the SNS pin is clamped to  $V_{SNSFH}$ , which is the fault voltage level. To make sure that this voltage is not higher than the system can tolerate, TI has correlated the voltage coming in on the DIAG\_EN pin with the maximum voltage out on the SNS pin. If DIAG\_EN is between  $V_{IH}$  and 3.3 V, the maximum output on the SNS pin is approximately 3.3 V. However, if the voltage at DIAG\_EN is above 3.3 V, then the fault SNS voltage,  $V_{SNSFH}$ , tracks that voltage up to 5 V. Tracking is done because the GPIO voltage output that is powering the diagnostics through DIAG\_EN is close to the maximum acceptable ADC voltage within the same microcontroller. Therefore, the sense resistor value,  $R_{SNS}$ , can be chosen to maximize the range of currents needed to be measured by the system. The  $R_{SNS}$  value must be chosen based on application need. The maximum usable  $R_{SNS}$  value is bounded by the ADC minimum acceptable voltage,  $V_{ADC,min}$ , for the smallest load current needed to be measured by the system,  $I_{LOAD,min}$ . The minimum acceptable  $R_{SNS}$  value has to ensure the  $V_{SNS}$  voltage is below the  $V_{SNSFH}$  value so that the system can determine faults. This difference between the maximum readable current through the SNS pin,  $I_{LOAD,max} \times R_{SNS}$ , and the  $V_{SNSFH}$  is called the headroom voltage,  $V_{HR}$ . The headroom voltage is determined by the system but is important so that there is a difference between the maximum readable current and a fault condition. Therefore, the minimum  $R_{SNS}$  value has to be the  $V_{SNSFH}$  minus the  $V_{HR}$  times the sense current ratio,  $K_{SNS}$  divided by the maximum load current the system must measure,  $I_{LOAD,max}$ . Use the following equation to see the boundary equation.

$$(V_{SNSFH} - V_{HR}) \times K_{SNS} / I_{LOAD,max} \leq R_{SNS} \leq V_{ADC,min} \times K_{SNS} / I_{LOAD,min} \quad (1)$$



**Figure 8-2. Voltage Indication on the Current-Sense Pin**

The maximum current the system wants to read,  $I_{LOAD,max}$ , must be below the current-limit threshold because after the current-limit threshold is tripped the  $V_{SNS}$  value goes to  $V_{SNSFH}$ . Additionally, currents being measured must be below 6 A to ensure that the current sense output is not saturated.

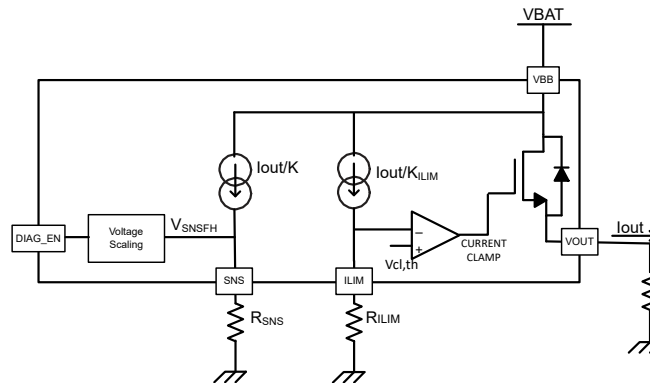

**Figure 8-3. Current-Sense and Current-Limit Block Diagram**

Because this scheme adapts based on the voltage coming in from the MCU, there is no need to have a Zener diode on the SNS pin to protect from high voltages.

### 8.3.2 Programmable Current Limit

A high-accuracy current limit allows higher reliability, which protects the power supply during short circuit or power up. Also, a current limit can save system costs by reducing PCB traces, connector size, and the capacity of the preceding power stage.

Current limit offers protection from over-stressing to the load and integrated power FET. Current limit holds the current at the set value, and pulls up the SNS pin to  $V_{SNSFH}$  and asserts the FLT pin as diagnostic reports. The three current-limit thresholds are:

- External programmable current limit – An external resistor,  $R_{ILIM}$ , is used to set the channel current limit. When the current through the device exceeds  $I_{CL}$  (current limit threshold), a closed loop steps in immediately.  $V_{GS}$  voltage regulates accordingly, leading to the  $V_{DS}$  voltage regulation. When the closed loop is set up, the current is clamped at the set value. The external programmable current limit provides the capability to set the current-limit value by application.

Additionally, this value can be dynamically changed by changing the resistance on the ILIM pin. This information can be seen in the [Applications](#) section.



- Internal current limit:  $I_{LIM}$  pin shorted to ground — If the external current limit is out of range on the lower end or the  $I_{LIM}$  pin is shorted to ground, the internal current limit is fixed and typically 12 A. To use the internal current limit for large-current applications, tie the  $I_{LIM}$  pin directly to the device GND.
- Internal current limit:  $I_{LIM}$  pin open — If the external resistor is out of range on the higher end or the  $I_{LIM}$  pin is open, the current limit reverts to 6 A or half the current limit range. This level is still above the nominal operation for the device to operate in DC STEADY state, but is low enough that if a pin fault occurs and the  $R_{ILIM}$  opens up, the current does not default to the highest rating and put additional stress on the power supply.

Both the internal current limit ( $I_{lim,nom}$ ) and external programmable current limit are always active when  $V_{BB}$  is powered and EN is high. The lower value one (of  $I_{LIM}$  and the external programmable current limit) is applied as the actual current limit. The typical deglitch time for the current limit to assert is 2.5  $\mu$ s.

Note that if a GND network is used (which leads to the level shift between the device GND and board GND), the  $I_{LIM}$  pin must be connected with device GND. Use Equation 2 to calculate  $R_{ILIM}$ .

$$R_{ILIM} = K_{CL} / I_{LIM} \quad (2)$$

For better protection from a "hot short" condition (when  $V_{BB}$  is high, channel is on, and a short to GND happens suddenly), an overcurrent protection, OVCR, circuit is triggered that makes sure to limit the maximum current the device allows to go through. With this OVCR, the device is protected during "hot short" events.

For more information about the current limiting feature, see the [Short-Circuit and Overload Protection](#) section.

### 8.3.2.1 Capacitive Charging

The following figure shows the typical setup for a capacitive load application and the internal blocks that function when the device is used. Note that all capacitive loads have an associated "load" in parallel with the capacitor that is described as a resistive load but in reality it can be inductive or resistive.

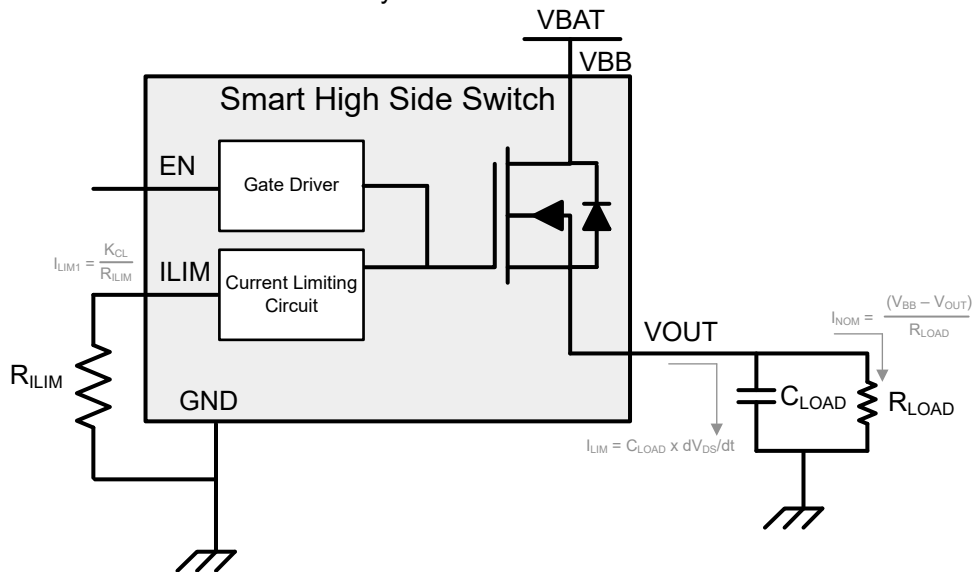

Figure 8-4. Capacitive Charging Circuit

The first thing to check is that the nominal DC current,  $I_{NOM}$ , is acceptable for the TPS1HC30-Q1 device. This check can easily be done by taking the  $R_{\theta JA}$  from the [Thermal Information](#) section and multiplying the  $R_{ON}$  of the TPS1HC30-Q1 and the  $I_{NOM}$  with it, add the ambient temperature and if that value is below the thermal shutdown value the device can operate with that load current. For an example of this calculation see the [Applications](#) section.

The second key care about for this application is to make sure that the capacitive load can be charged up completely without the device hitting thermal shutdown. The reason is because if the device hits thermal

shutdown during the charging, the resistive nature of the load in parallel with the capacitor starts to discharge the capacitor over the duration the TPS1HC30-Q1 is off. Note that there are some application with high enough load impedance that the TPS1HC30-Q1 hitting thermal shutdown and trying again is acceptable; however, for the majority of applications, the system must be designed so that the TPS1HC30-Q1 does not hit thermal shutdown while charging the capacitor.

With the current clamping feature of the TPS1HC30-Q1, capacitors can be charged up at a lower inrush current than other high current limit switches. This lower inrush current means that the capacitor takes a little longer to charge all the way up. The time that it takes to charge up follows the equation below.

$$I_{LIM} = C \times d(V_{BB} - V_{DS}) / dt \quad (3)$$

However, because the  $V_{DS}$  for a typical 3.3-A application is much less than the  $V_{BB}$  voltage ( $V_{DS} \cong 3.3A \times 0.03 \Omega = 100 \text{ mV}$ ,  $V_{BB} \cong 13.5 \text{ V}$ ), the equation can be rewritten and approximated as

$$dt = C \times dV_{BB} / I_{LIM} \quad (4)$$

The following figure pictures charge timing.

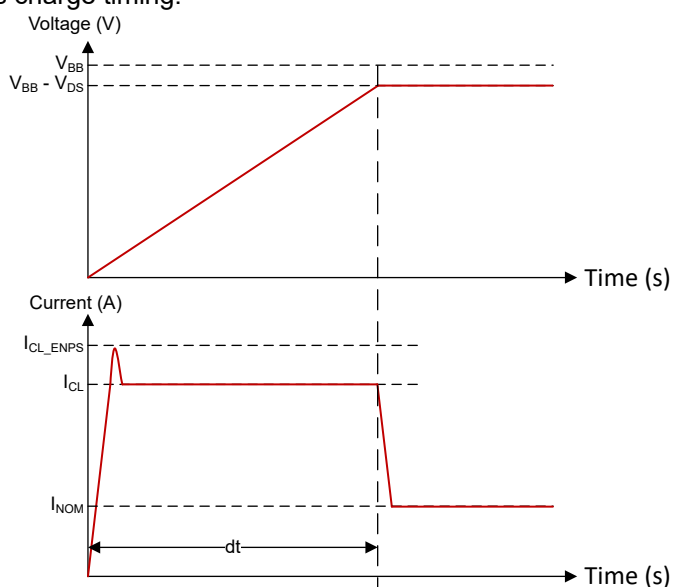

**Figure 8-5. Capacitive Charging Timing**

Using this  $dt$  calculated based on the current limit, and finding the transient thermal impedance value at half the  $dt$  value, the junction temperature rise can be approximated by the [Equation 5](#).

$$\Delta T_J \cong 2/3 \times V_{BB} \times I_{LIM} \times R_{\theta JA}(dt/2) \quad (5)$$

For more information about capacitive charging with high-side switches, see the [How to Drive Resistive, Inductive, Capacitive, and Lighting Loads application note](#). This application note has information about the thermal modeling available along with quick ways to estimate if a high-side switch can charge a capacitor to a given voltage.

### 8.3.3 Inductive-Load Switching-Off Clamp

When an inductive load is switching off, the output voltage is pulled down to negative, due to the inductance characteristics. The power FET can break down if the voltage is not clamped during the current-decay period. To protect the power FET in this situation, internally clamp the drain-to-source voltage, namely  $V_{DS,clamp}$ , the clamp diode between the drain and gate.

$$V_{DS,clamp} = V_{BAT} - V_{OUT} \quad (6)$$

During the current-decay period ( $T_{\text{DECAY}}$ ), the power FET is turned on for inductance-energy dissipation. Both the energy of the power supply ( $E_{\text{BAT}}$ ) and the load ( $E_{\text{LOAD}}$ ) are dissipated on the high side power switch itself, which is called  $E_{\text{HSD}}$ . If resistance is in series with inductance, some of the load energy is dissipated in the resistance.

$$E_{\text{HSD}} = E_{\text{BAT}} + E_{\text{LOAD}} = E_{\text{BAT}} + E_L - E_R \quad (7)$$

From the high side power switch view,  $E_{\text{HSD}}$  equals the integration value during the current-decay period.

$$E_{\text{HSD}} = \int_0^{T_{\text{DECAY}}} V_{\text{DS,clamp}} \times I_{\text{OUT}}(t) dt \quad (8)$$

$$T_{\text{DECAY}} = \frac{L}{R} \times \ln\left(\frac{R \times I_{\text{OUT(MAX)}} + |V_{\text{OUT}}|}{|V_{\text{OUT}}|}\right) \quad (9)$$

$$E_{\text{HSD}} = L \times \frac{V_{\text{BAT}} + |V_{\text{OUT}}|}{R^2} \times \left[ R \times I_{\text{OUT(MAX)}} - |V_{\text{OUT}}| \ln\left(\frac{R \times I_{\text{OUT(MAX)}} + |V_{\text{OUT}}|}{|V_{\text{OUT}}|}\right) \right] \quad (10)$$

When  $R$  approximately equals 0,  $E_{\text{HSD}}$  can be given simply as:

$$E_{\text{HSD}} = \frac{1}{2} \times L \times I_{\text{OUT(MAX)}}^2 \times \frac{V_{\text{BAT}} + |V_{\text{OUT}}|}{R^2} \quad (11)$$

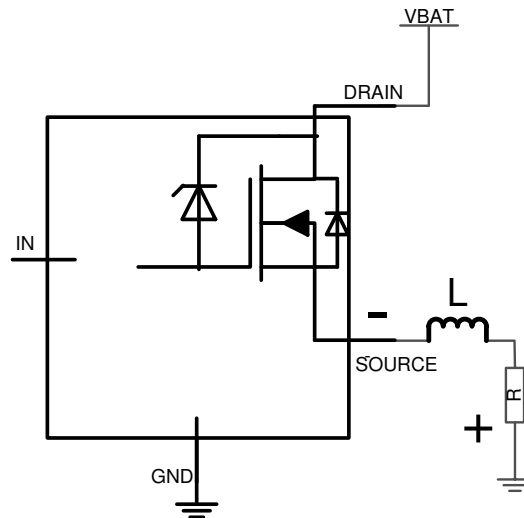

**Figure 8-6. Driving Inductive Load**

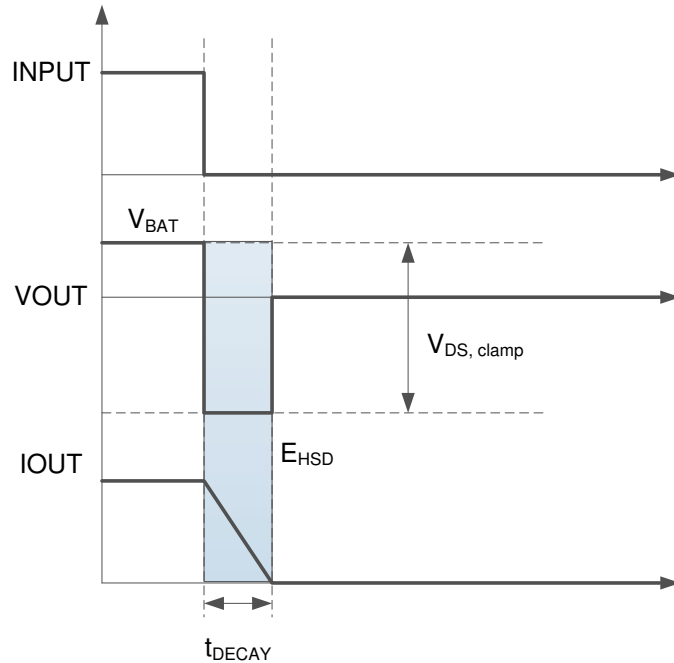

Figure 8-7. Inductive-Load Switching-Off Diagram

As discussed previously, when switching off, battery energy and load energy are dissipated on the high side power switch, which leads to the large thermal variation. For each high side power switch, the upper limit of the maximum safe power dissipation depends on the device intrinsic capacity, ambient temperature, and board dissipation condition. TI provides the upper limit of single-pulse energy that devices can tolerate under the test condition:  $V_{VS} = 13.5\text{ V}$ , inductance from 0.1 mH to 400 mH,  $R = 0\ \Omega$ , FR4 2s2p board, 2-  $\times$  70- $\mu\text{m}$  copper, 2-  $\times$  35- $\mu\text{m}$  copper, thermal pad copper area 600  $\text{mm}^2$ .

### 8.3.4 Full Protections and Diagnostics

Table 8-1 is when DIAG\_EN is enabled. When DIAG\_EN is low, current sense and FLT are disabled. The output is in high-impedance mode. For details, refer to the following table.

Table 8-1. Diagnostic Enable Logic Table

DIAG_EN	IN Condition	Protections and Diagnostics
HIGH	ON	See <a href="#">Fault Table</a>
	OFF	
LOW	ON	Diagnostics disabled, protection normal SNS and $\overline{\text{FLT}}$ are high impedance
	OFF	

Table 8-2. Fault Table

Conditions	EN	VOUT	Latch	FLT	SNS	Behavior	Recovery
Normal	L	L	x	Hi-Z	0	Normal	
	H	$I_{\text{LOAD}} \times R_{\text{ON}}$	x	Hi-Z	$I_{\text{Load}} / K_{\text{sns}}$	Normal	
Overcurrent	H	$V_{\text{BB}} - I_{\text{LIM}} \times R_{\text{LOAD}}$	x	L	$V_{\text{SNSFH}}$	Holds the current at the current limit until thermal shutdown or when the overcurrent event is removed	

Table 8-2. Fault Table (continued)

Conditions	EN	VOUT	Latch	FLT	SNS	Behavior	Recovery
STG, Relative Thermal Shutdown, Absolute Thermal Shutdown	H	H/L	L	L	$V_{SNSFH}$	Shuts down when devices hits relative or absolute thermal shutdown	Auto retries when $T_{HYS}$ is met and it has been longer than $t_{RETRY}$ amount of time
	H	H/L	H	L	$V_{SNSFH}$	Shuts down when devices hits relative or absolute thermal shutdown	Stays off until latch or enable is toggled
Open load, STB	H	H	x	Hi-Z	$I_{Load} / K_{SNS} = \sim 0$	Normal behavior, user can judge through the SNS pin output if it is an open load or not	
	L	H	x	L	$V_{SNSFH}$	Internal pullup resistor is active. If $V_{BB} - V_{OUT} < V_{OL}$ then fault active.	Clears when fault goes away
Reverse Polarity	x	x	x	x	x	Channel turns on to lower power dissipation. Current into ground pin is limited by external ground network.	

Table 8-3. Deglitch Time for Each Fault Condition

Fault Condition	Deglitch Time
ILIM	2.5 $\mu$ s
$T_{REL}$	2.5 $\mu$ s
$T_{ABS}$	20 $\mu$ s
Open Load	500 $\mu$ s

### 8.3.4.1 Short-Circuit and Overload Protection

TPS1HC30-Q1 provides output short-circuit protection to ensure that the device prevents current flow in the event of a low impedance path to GND, removing the risk of damage or significant supply droop. The device is assured to protect against short-circuit events regardless of the state of the ILIM pins and with up to 28-V supply at 125°C.

The following figure shows the behavior of the TPS1HC30-Q1 when the device is enabled into a short circuit.

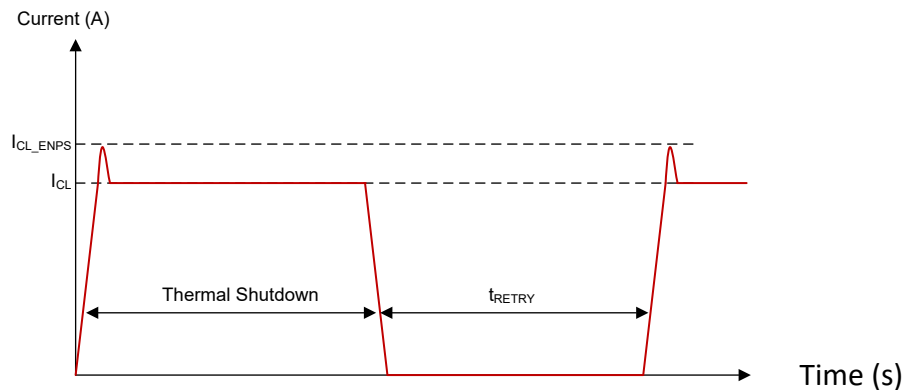

Figure 8-8. Enable into Short-Circuit Behavior (LATCH=0)

Due to the low impedance path, the output current rapidly increases until it hits the current limit threshold. Due to the response time of the current limiting circuit, the measured maximum current can temporarily exceed the  $I_{CL}$  value defined as  $I_{CL\_ENPS}$ , however, it settles to the current limit regulation value.

In this state, high power is dissipated in the FET, so eventually the internal thermal protection temperature for the FET is reached and the device safely shuts down. Then, if LATCH pin is low, the part waits  $t_{RETRY}$  amount of time and turns back on.

Figure 8-9 shows the behavior of the TPS1HC30-Q1 when a short circuit occurs when the device is in the on-state and already outputting current. When the internal pass FET is fully enabled, the current clamping settling time is slower so to ensure overshoot is limited the device implements a fast-trip level at a level  $I_{OVCR}$ . When this fast-trip threshold is hit, the device immediately shuts off for a short period of time before quickly re-enabling and clamping the current to  $I_{CL}$  level after a brief transient overshoot to the higher peak current ( $I_{CL\_ENPS}$ ) level. The device then keeps the current clamped at the regulation current limit until the thermal shutdown temperature is hit and the device safely shuts off.

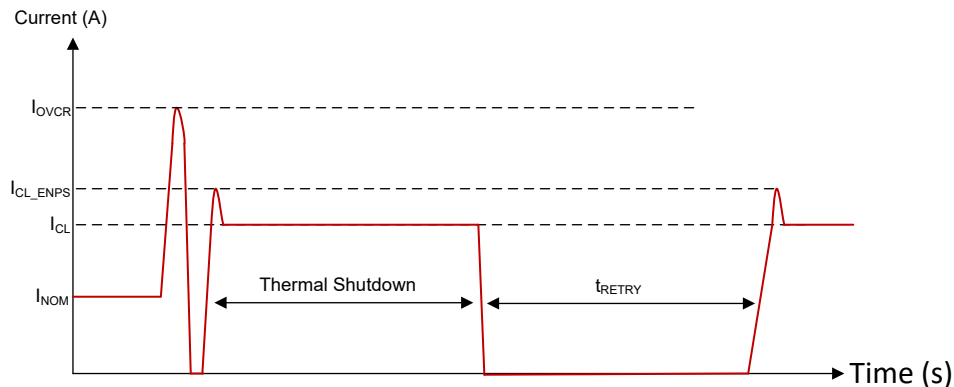

Figure 8-9. On-State Short-Circuit Behavior

Overload Behavior shows the behavior of the TPS1HC30-Q1 when there is a small change in impedance that sends the load current above the  $I_{CL}$  threshold. The current rises to  $I_{CL\_LINPK}$  above the regulation level. Then the current limit regulation loop kicks in and the current drops to the  $I_{CL}$  value.

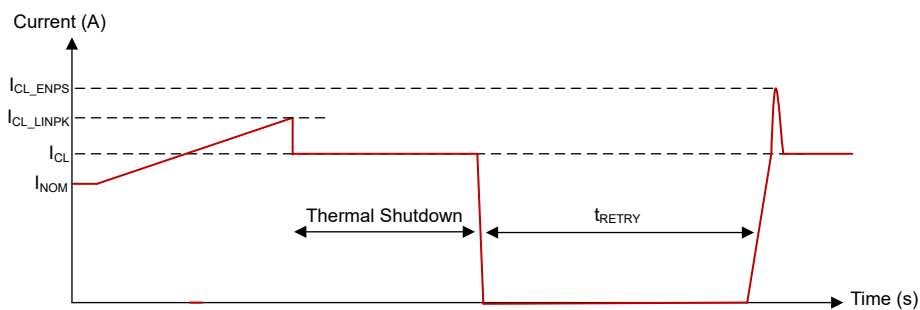

Figure 8-10. Overload Behavior

In all of these cases, the internal thermal shutdown is safe to hit repetitively. There is no device risk or lifetime reliability concerns from repeatedly hitting this thermal shutdown level.

#### 8.3.4.2 Open-Load and Short-to-Battery Detection

When the main channel is enabled, faults are diagnosed by reading the voltage on the SNS or  $\overline{FLT}$  pin and judged by the user. A benefit of high-accuracy current sense is that this device can achieve a very low open-load detection threshold, which correspondingly expands the normal operation region. TI suggests 15 mA as the upper limit for the open-load detection threshold and 30 mA as the lower limit for the normal operation current. In Figure 8-11, the recommended open-load detection region is shown as the dark-shaded region and the light-shaded region is for normal operation. As a guideline, do not overlap these two regions.

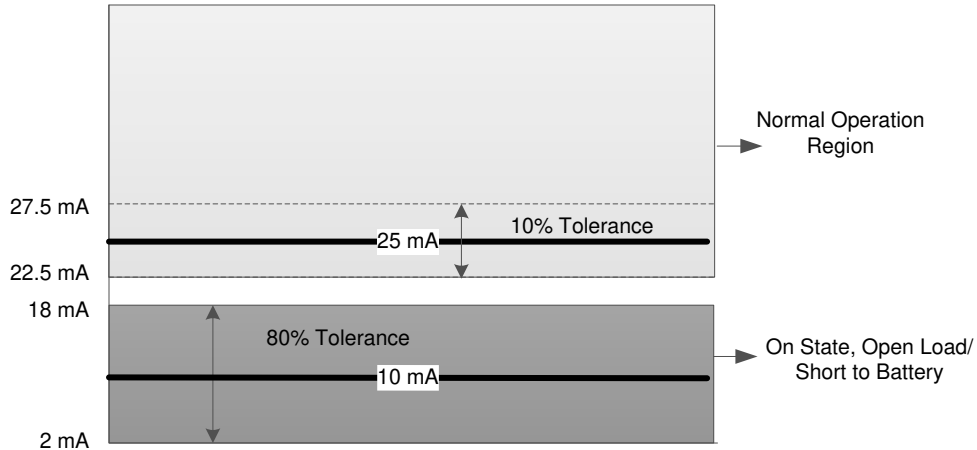

Figure 8-11. On-State Open-Load Detection and Normal-Operation Diagram

In the off state, if a load is connected, the output voltage is pulled to 0 V. In the case of an open load, the output voltage is close to the supply voltage,  $V_{BB} - V_{OUT} < V_{ol,off}$ . The FLT pin goes low to indicate the fault to the MCU, and the SNS pin is pulled up to  $V_{SNSFH}$ . There is always a leakage current  $I_{ol,off}$  present on the output, due to the internal logic control path or external humidity, corrosion, and so forth. Thus, TI implemented an internal pullup resistor to offset the leakage current. This pullup current must be less than the output load current to avoid false detection in the normal operation mode. To reduce the standby current, TI implemented a switch in series with the pullup resistor controlled by the DIAG\_EN pin. The pullup resistor value is  $R_{pu} \leq 15 \text{ k}\Omega$ .

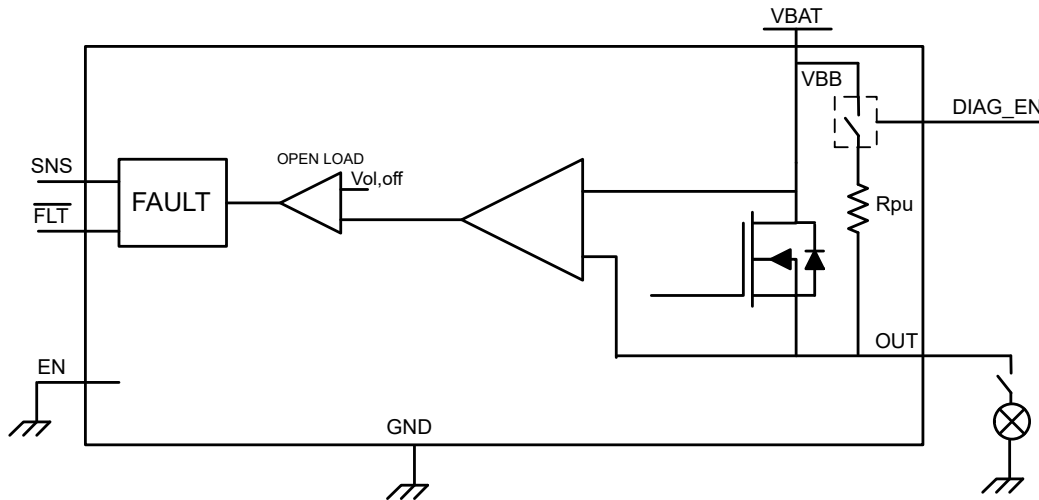

Figure 8-12. Open-Load Detection Circuit

### 8.3.4.3 Short-to-Battery Detection

Short-to-battery detection has the same detection mechanism and behavior as open-load detection, both in the on-state and off-state. There is no way to differentiate between open load and short-to-battery in this device, but the system detects the fault and protects accordingly. See [Table 8-2](#) for more details.

### 8.3.4.4 Reverse-Polarity and Battery Protection

Reverse-polarity, commonly referred to as reverse battery, occurs when the ground of the device goes to the battery potential,  $V_{GND} = V_{BAT}$ , and the supply pin goes to ground,  $V_{BB} = 0 \text{ V}$ . In this case, if the EN pin has a path to the "ground" plane, then the FE turn son to lower the power dissipation through the main channel and prevent current flow through the body diode. Note that the resistor, diode ground network (if there is not a central blocking diode on the supply) must be present for the device to protect itself during a reverse battery event.

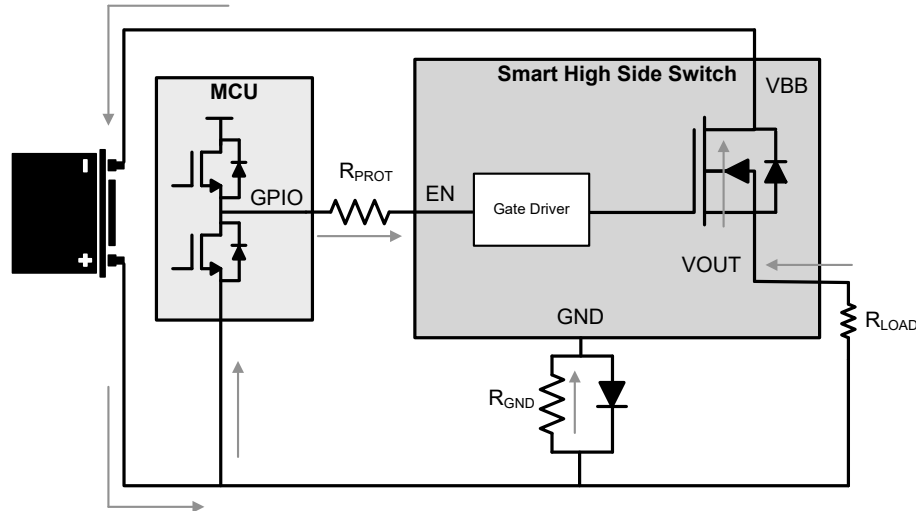

Figure 8-13. Reverse Battery Circuit

For more external protection circuitry information, see [Reverse Current Protection](#). See the fault truth table for more details.

#### 8.3.4.5 Latch-Off Mode

The TPS1HC30-Q1 comes with a latch functionality that decides after the channel is shut down due to a fault, whether or not to automatically try and turn back on, or stay off until other action is taken. This functionality is done by holding the LATCH pin high for latch-off functionality or holding LATCH low for auto-retry functionality.

The order the events occur is:

1. The device shuts down due to fault (thermal shutdown)
2. Wait  $t_{RETRY}$
3. If LATCH = 0
  - a. Turn back on the channel
4. If LATCH = 1
  - a. Keep off until LATCH = 0 || EN = 0
    - i. Then if LATCH = 0 and EN = 1
      1. Turn on channel into auto-retry mode
    - ii. If LATCH = 1 and EN = 1
      1. Turn on channel into latch mode where if another fault occurs then output is latched off again

For more information, see [Thermal Protection Behavior](#).

#### 8.3.4.6 Thermal Protection Behavior

The thermal protection behavior can be split up into three categories of events that can happen. [Figure 8-14](#) shows each of these categories.

1. **Relative thermal shutdown:** The device is enabled into an overcurrent event. The DIAG\_EN pin is high so that diagnostics can be monitored on SNS and FLT (however, DIAG\_EN being high is not necessary for all protection features to function). The output current rises up to the  $I_{LIM}$  level and the FLT goes low while the SNS goes to  $V_{SNSFH}$ . With this large amount of current going through, the junction temperature of the FET increases rapidly with respect to the controller temperature. When the power FET temperature rises  $T_{REL}$  amount above the controller junction temperature  $\Delta T = T_{FET} - T_{CON} > T_{REL}$ , the device shuts down. The faults are continually shown on SNS and FLT and the part waits for the  $t_{RETRY}$  timer to expire. When  $t_{RETRY}$  timer expires, because the LATCH pin is low and EN is still high, the device comes back on into this  $I_{LIM}$  condition.
2. **Absolute thermal shutdown:** The device is still enabled in an overcurrent event with DIAG\_EN high and LATCH still low. However, in this case the junction temperature rises up and hits an absolute reference



temperature,  $T_{ABS}$ , and then shuts down. The device does not recover until both  $T_J < T_{ABS} - T_{hys}$  and the  $t_{RETRY}$  timer has expired.

3. **Latch-off mode:** The device is enabled into an overcurrent event. The DIAG\_EN pin is high so that diagnostics can be monitored on SNS and FLT. The output current rises up to the  $I_{LIM}$  level and the FLT goes low while the SNS goes to  $V_{SNSFH}$ . If the part shuts down due to a thermal fault, either relative thermal shutdown or absolute thermal shutdown, the device does not enable the channel until either the LATCH pin OR the EN pin is toggled.

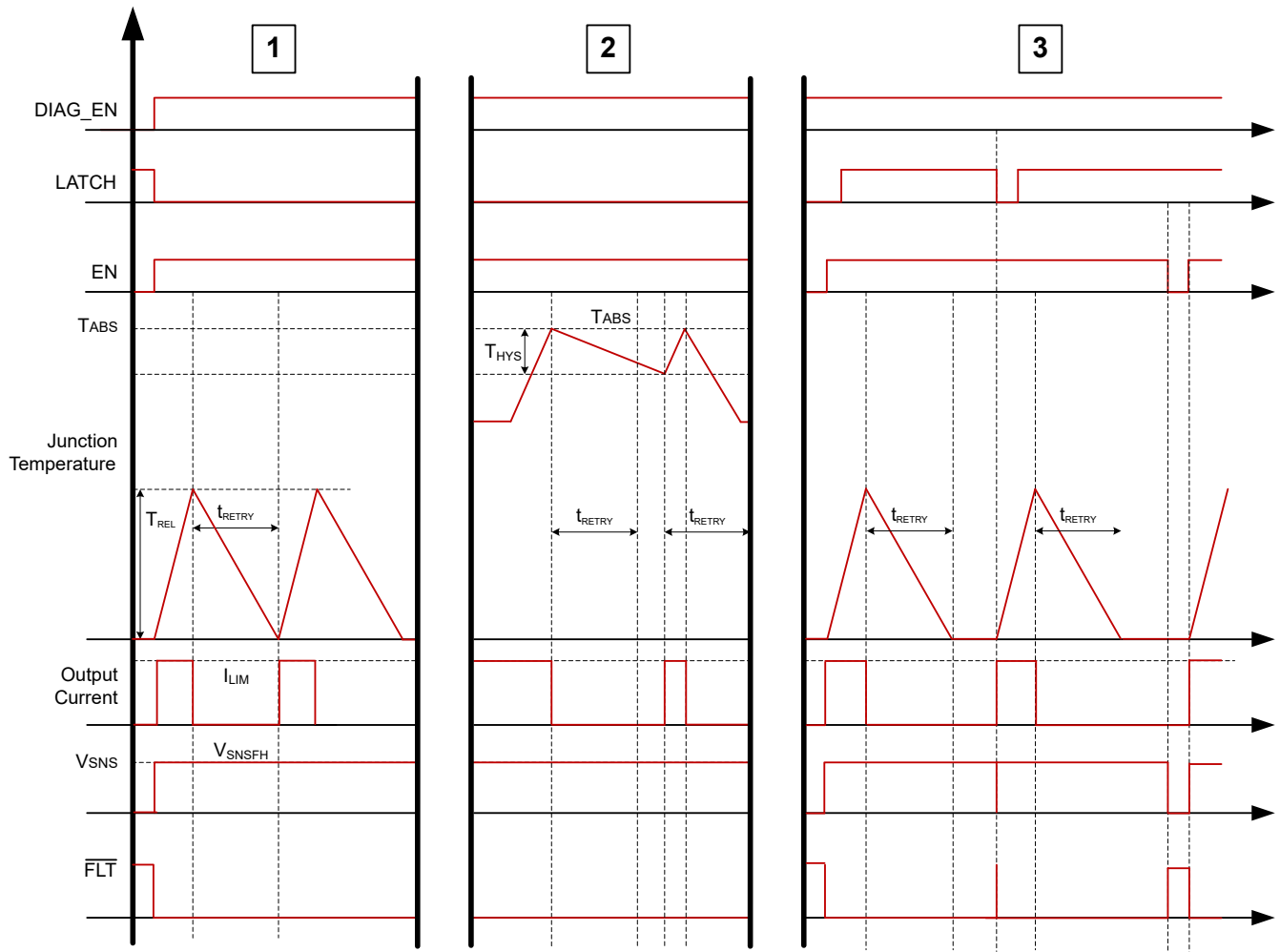

Figure 8-14. Thermal Behavior

#### 8.3.4.7 UVLO Protection

The device monitors the supply voltage  $V_{BB}$  to prevent unpredicted behaviors in the event that the supply voltage is too low. When the supply voltage falls down to  $V_{UVLOF}$ , the output stage is shut down automatically. When the supply rises up to  $V_{UVLOR}$ , the device turns on. If an overcurrent event trips the UVLO threshold, the device shuts off and comes back on into a current limit safely.

### 8.3.4.8 Loss of GND Protection

When loss of GND occurs, output is turned off regardless of whether the input signal is high or low.

**Case 1 (Loss of Device GND):** Loss of GND protection is active when the thermal pad (Tab),  $I_{C\_GND}$ , and current limit ground are one trace connected to the system ground, as shown in the following figure.

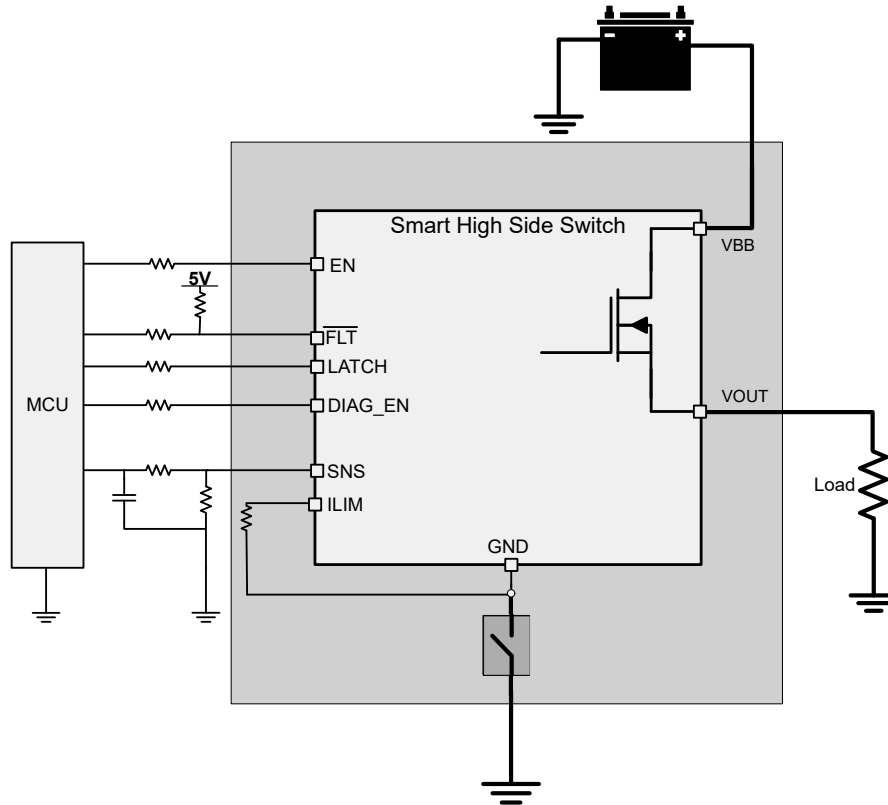
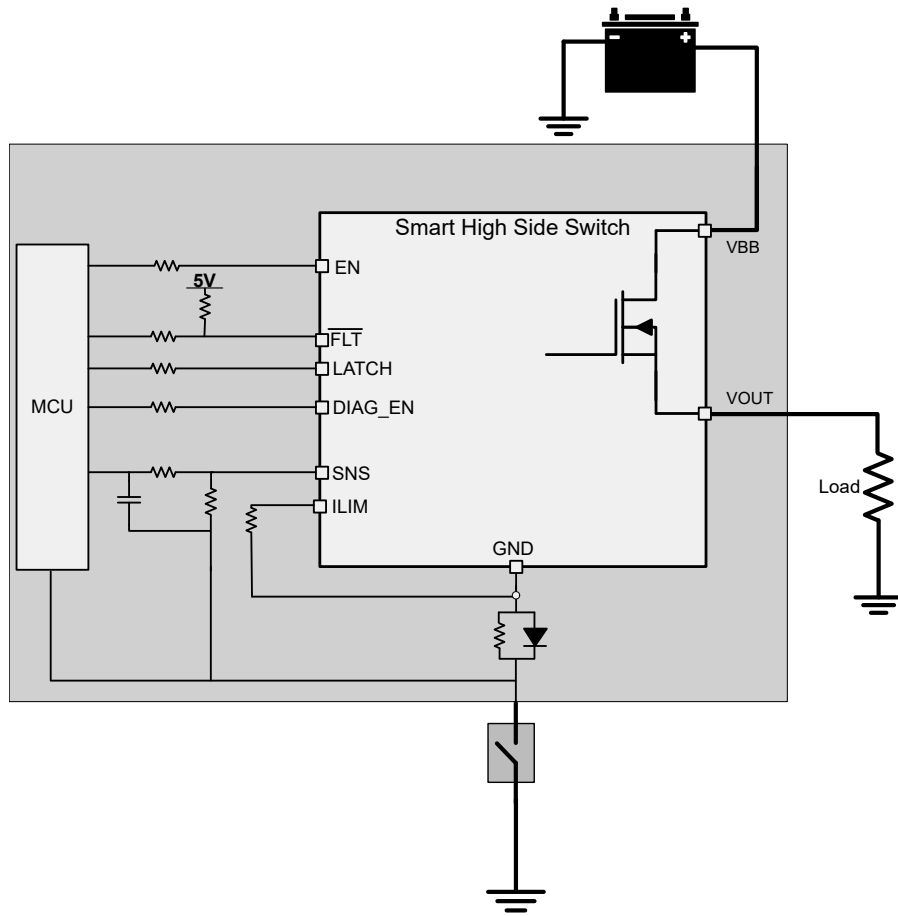

Figure 8-15. Loss of Device GND

**Case 2 (Loss of Module GND):** When the whole ECU module GND is lost, protections are also active. At this condition, the load GND remains connected.



**Figure 8-16. Loss of Module GND**

**ADVANCE INFORMATION**

### 8.3.4.9 Loss of Power Supply Protection

When loss of supply occurs, output is turned off regardless of whether the input is high or low. For a resistive or capacitive load, loss of supply protection is easy to achieve due to no more power. The worst case is a charged inductive load. In this case, the current is driven from all of the IOs to maintain the inductance output loop. TI recommends either the MCU serial resistor plus the GND network (diode and resistor in parallel) or external free-wheeling circuitry.

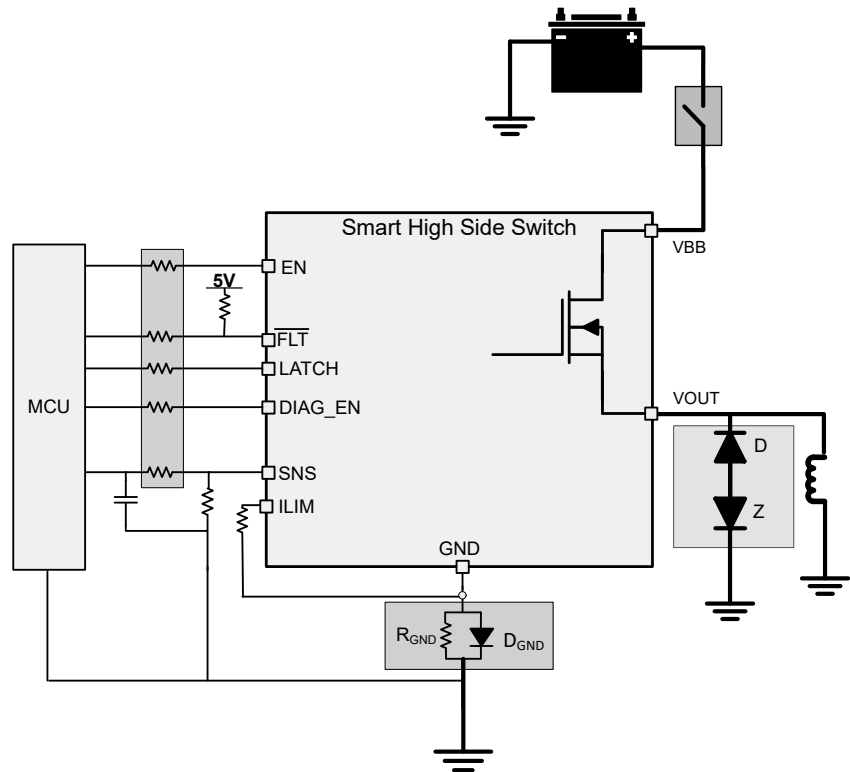
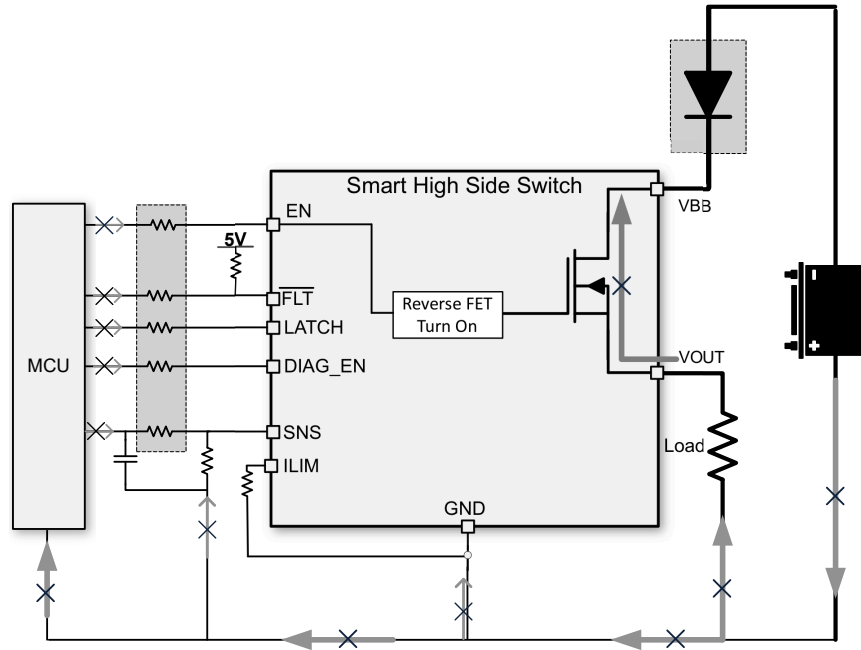

Figure 8-17. Loss of Battery

### 8.3.4.10 Reverse Current Protection

**Method 1:** Blocking diode connected with  $V_{BB}$ . Both the device and load are protected when in reverse polarity. The blocking diode does not allow any of the current to flow during reverse battery condition.



**Figure 8-18. Reverse Protection with Blocking Diode**

**Method 2 (GND Network Protection):** Only the high side device is protected under this connection. The load reverse current is limited by the impedance of the load itself. Note when reverse polarity happens, the continuous reverse current through the power FET must not make the heat build up be greater than the absolute maximum junction temperature. This can be calculated using the  $R_{ON(REV)}$  value and the  $R_{\theta JA}$  specification. No matter what types of connection are between the device GND and the board GND, if a GND voltage shift happens, ensure the following proper connections for the normal operation:

- Connect the current limit programmable resistor to the device GND.

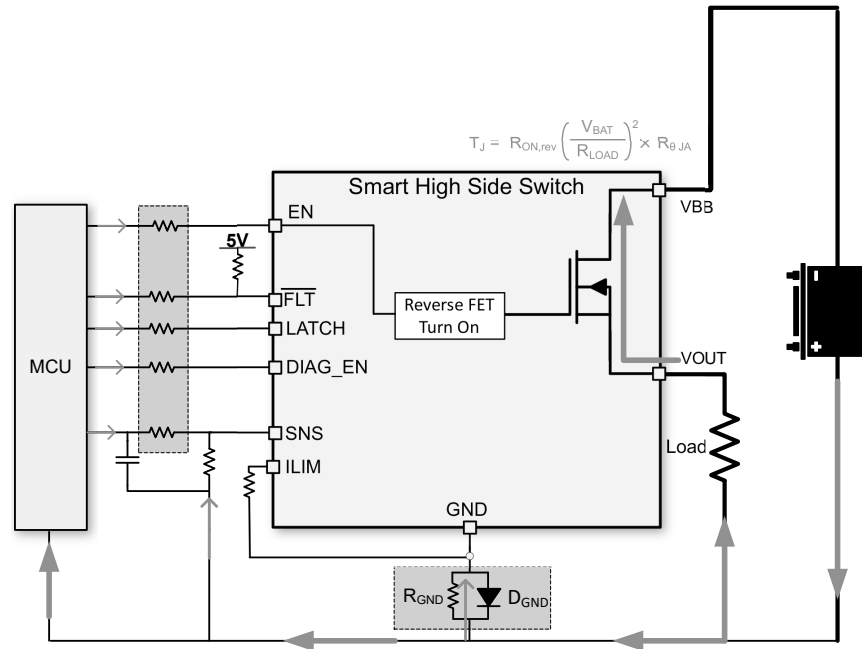

Figure 8-19. Reverse Protection with GND Network

- **Recommendation - Resistor and Diode in Parallel:** A peak negative spike can occur when the inductive load is switching off, which can damage the HSD or the diode. So, TI recommends a resistor in parallel with the diode when driving an inductive load. The recommended selections are a 1-k $\Omega$  resistor in parallel with an  $I_F > 100$ -mA diode. If multiple high side switches are used, the resistor and diode can be shared among devices.

If multiple high side power switches are used, the resistor can be shared among devices.

- **Ground Resistor:** The higher resistor value contributes to a better current limit effect when the reverse battery or negative ISO pulses.

$$R_{GND} \geq \frac{(-V_{CC})}{(-I_{GND})} \quad (12)$$

where

- $-V_{CC}$  is the maximum reverse battery voltage (typically  $-16$  V).
- $-I_{GND}$  is the maximum reverse current the ground pin can withstand, which is available in the [Absolute Maximum Ratings](#).
- **Ground Diode:** A diode is needed to block the reverse voltage, which also brings a ground shift based on the forward voltage of the diode. The ground diode must be  $\leq 400$  mV to have full current limit capability. If the forward voltage becomes higher, the current limit can also increase from what the  $R_{ILIM}$  resistor is set to. Additionally, the diode must be approximately 200-V reverse voltage for the ISO 7637 pulse 1 testing so that it does not get biased.

### 8.3.4.11 Protection for MCU I/Os

In many conditions, such as the negative ISO pulse, or the loss of battery with an inductive load, a negative potential on the device GND pin can damage the MCU I/O pins (more likely, the internal circuitry connected to the pins). Therefore, the serial resistors between MCU and HSS are required.

Also, for proper protection against loss of GND, TI recommends 5-k $\Omega$  resistance for the R<sub>PROT</sub> resistors.

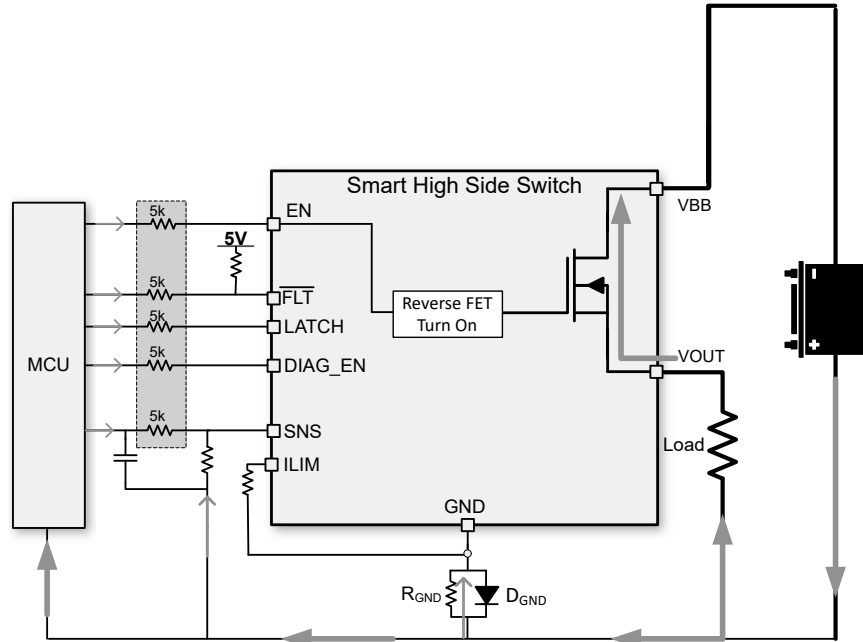

Figure 8-20. MCU I/O Protections

### 8.3.5 Diagnostic Enable Function

The diagnostic enable pin, DIAG\_EN, offers multiplexing of the microcontroller diagnostic input for current sense or digital status, by sharing the same sense resistor and ADC line or I/O port among multiple devices.

In addition, during the output-off period, the diagnostic disable function lowers the current consumption for the standby condition. The three working modes in the device are normal mode ( $I_Q$ ), standby mode ( $I_{STBY}$ ), and standby mode with diagnostic ( $I_{DIA}$ ). If off-state power saving is required in the system, the standby current is < 500 nA with DIAG\_EN low. If the off-state diagnostic is required in the system, the typical standby current is around 1 mA with DIAG\_EN high.

## 8.4 Device Functional Modes

### 8.4.1 Working Mode

The three working modes in the device are normal mode, standby mode, and standby mode with diagnostic. If an off-state power saving is required in the system, the standby current is less than 500 nA with EN and DIAG\_EN low. If an off-state diagnostic is required in the system, the typical standby current is around 1.2 mA with DIAG\_EN high. Note that entering standby mode requires IN low and  $t > t_{STBY}$ .  $t_{STBY}$  is the standby mode deglitch time, which is used to avoid false triggering or interfere with PWM switching. The following figure shows a work mode state-machine state diagram.

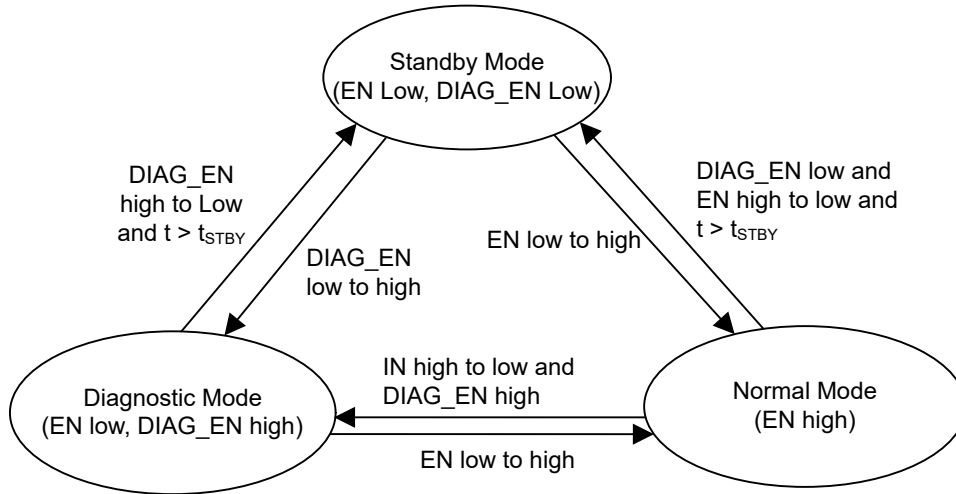

Figure 8-21. Work Mode State Machine



## 9 Application and Implementation

### Note

Information in the following applications sections is not part of the TI component specification, and TI does not warrant its accuracy or completeness. TI's customers are responsible for determining suitability of components for their purposes, as well as validating and testing their design implementation to confirm system functionality.

### 9.1 Application Information

The following discussion notes how to implement the device to distinguish the different fault modes and implement a transient-pulse immunity test.

In some applications, open load, short-to-battery, and short to GND must be distinguished from each other. This action requires two steps.

### 9.2 Typical Application

Figure 9-1 shows an example of how to design the external circuitry parameters.

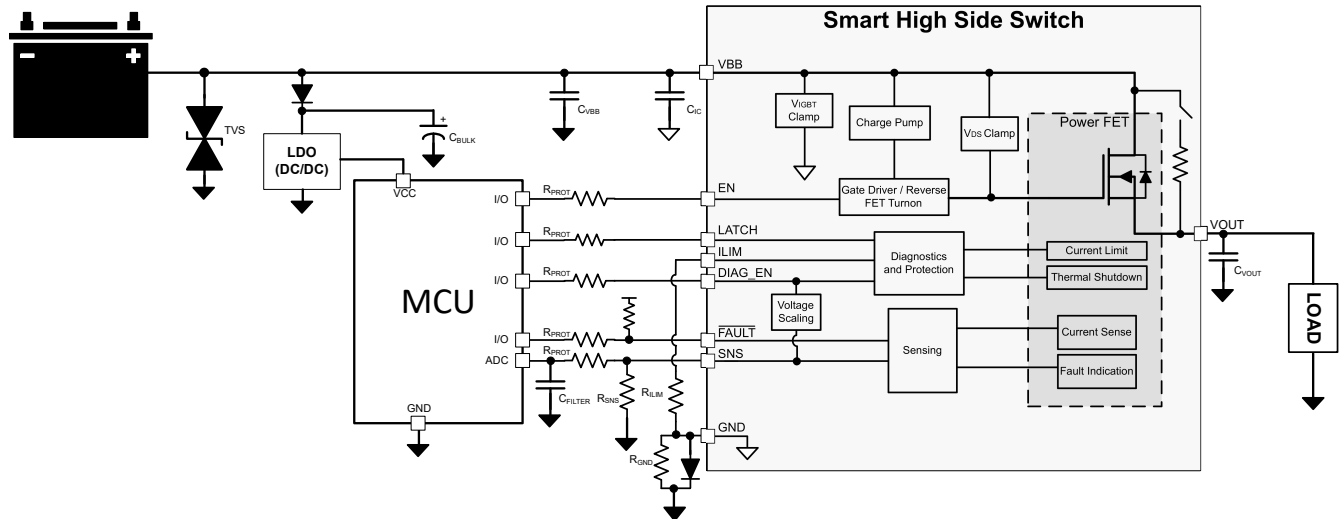

Figure 9-1. Typical Application Circuitry

### 9.2.1 Design Requirements

Component	Description	Purpose
TVS	SMBJ36CA (optional)	Filter voltage transients coming from battery (ISO7637-2)
CVBB	220 nF (optional)	Better EMI performance
CIC	100 nF	Minimal amount of capacitance on input for EMI mitigation
CBULK	2-10 uF (optional)	There to hold the rail for the LDO; however, helps to filter voltage transients on supply rail. Not a requirement but can be useful for ISO7637-2 transients.
RPROT	5 k	Protection resistor for microcontroller and device I/O pins
RILIM	7 k – 70 k	Set current limit threshold
RSNS	1 k	Translate the sense current into sense voltage.
CFILTER	100 nF	Coupled with RPROT on the SNS line creates a low pass filter to filter out noise going into the ADC of the MCU
CVOUT	22 nF	Improves EMI performance, filtering of voltage transients
RGND	1 kΩ	Stabilize GND potential during turn-off of inductive load
DGND	BAS21 Diode	Keeps GND close to system ground during normal operation

### 9.2.2 Detailed Design Procedure

To keep maximum voltage on the SNS pin at an acceptable range for the system, use the following equation to calculate the  $R_{SNS}$ . To achieve better current sense accuracy. A 1% accuracy or better resistor is preferred.

$$(V_{SNSFH} - V_{HR}) \times K_{SNS} / I_{LOAD,max} \leq R_{SNS} \leq V_{ADC,min} \times K_{SNS} / I_{LOAD,min} \quad (13)$$

**Table 9-1. Typical Application**

Parameter	Value
$V_{DIAG\_EN}$	5 V
$I_{LOAD,max}$	6 A
$I_{LOAD,min}$	20 mA
$V_{ADC,min}$	5 mV
$V_{HR}$	1 V

For this application, an  $R_{SNS}$  value of approximately 1 kΩ can be chosen to satisfy the equation requirements.

$$(5 V - 1 V) \times 1814 / 6 A \leq \approx 1 k\Omega \leq 5 mV \times 11814 / 20 mA \quad (14)$$

In other applications, more emphasis can be put on the lower end measurable values which increases  $R_{SNS}$ . Likewise, if the higher currents are of more interest the  $R_{SNS}$  can be decreased. Note that the maximum current that can be measured without saturation is 12 A.

Having the maximum SNS voltage scale with the  $DIAG\_EN$  voltage removes the need for a Zener diode on the SNS pin going to the ADC.

To set the programmable current limit value at 7 A, use the following equation to calculate the  $R_{LIM}$ .

$$R_{LIM} = K_{CL} / I_{LIM} = 90 / 7 = 12.8 k\Omega \quad (15)$$

TI recommends  $R_{PROT} = 5 k\Omega$  to ensure the current going into the digital pins (EN,  $DIAG\_EN$ , LATCH) is limited.

TI recommends a 1-kΩ resistor and 200-V, 0.2-A diode (BAS21 for example) for the GND network.

### 9.2.2.1 Dynamically Changing Current Limit

The current limit threshold can be changed dynamically by altering the resistance going from the current limit pin to the ground of the device on the fly. This alteration allows the system to have a different current limit for start-up, when there can be significant inrush current, and during normal operation. The way this is commonly done is by putting two resistors in parallel on the ILIM pin and having a switch to enable or disable one of the resistors. This set-up can be seen in the figure below. Alternatively, a digital potentiometer can be used to adjust the impedance on the ILIM pin on the fly. Care must be taken so that the capacitance on the ILIM pin is below approximately 100 pF because it can cause the current regulation loop to become unstable. The most common application where this feature is useful is capacitive loads.

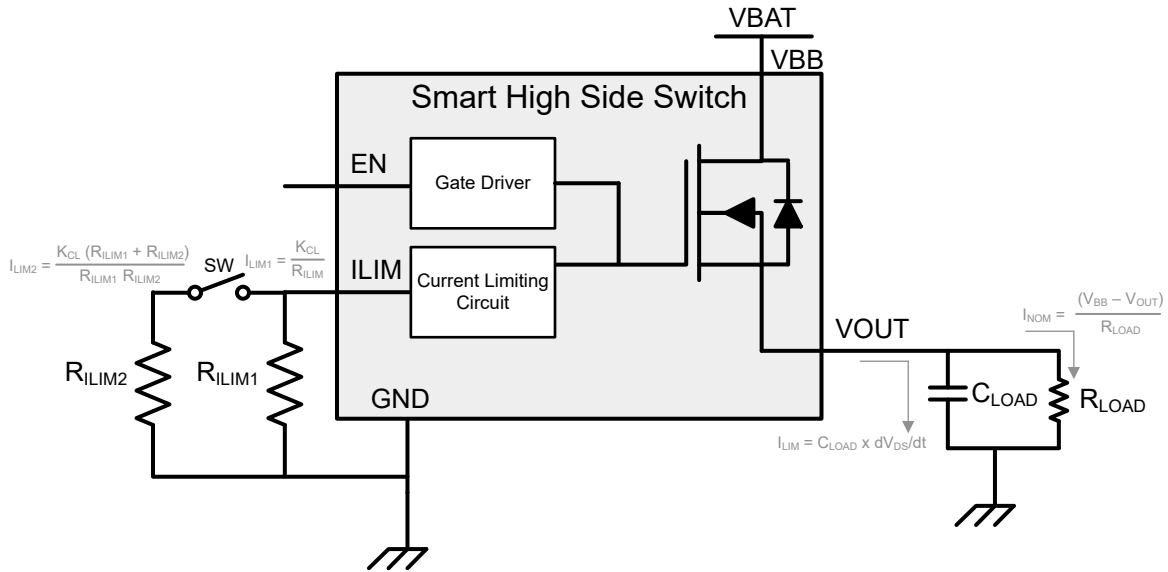
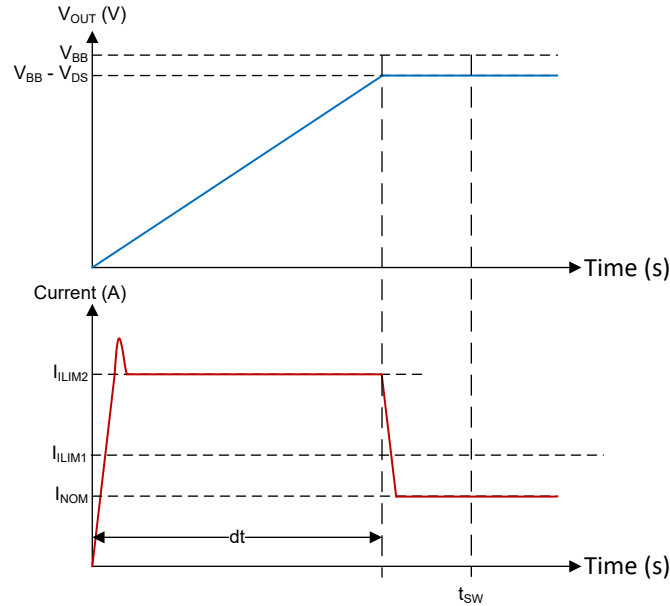

Figure 9-2. Dynamic Changing Current Limit Setup

In a capacitive charging case, the initial current to charge the capacitor is the inrush current. Depending on the system requirements, dynamically changing the current limit can help either charge up a capacitor faster or charge up a larger capacitor. To allow a higher inrush level of current through in the beginning, the switch can be closed making the current limit be according to the equation below.

$$I_{LIM2} = K_{CL}(R_{ILIM1} + R_{ILIM2}) / (R_{ILIM1} \times R_{ILIM2}) \quad (16)$$

When the inrush event is over and the output voltage is charged up, the switch opens and the current limit is just the  $R_{ILIM1}$  equivalent level. This timing can be seen in the figure below.



**Figure 9-3. Capacitive Charging Changing Current Limit**

Alternatively, if the switch is open, the current limit starts out at a lower value and then the switch can be closed when the capacitance gets charged up. This lower current limit level allows higher value capacitance to be charged up. The timing diagram can be seen below.

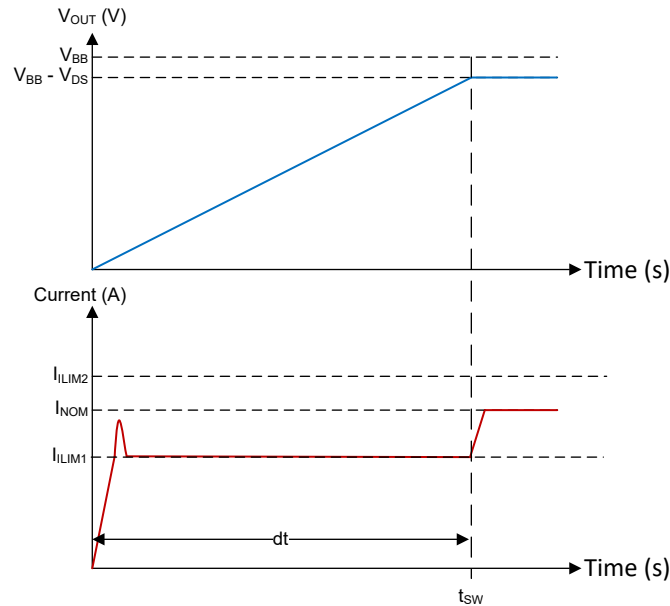

**Figure 9-4. Large Capacitive Charging Changing Current Limit**

### 9.2.2.2 EMC Transient Disturbances Test

Due to the severe electrical conditions in the automotive environment, immunity capacity against electrical transient disturbances is required, especially for a high side power switch, which is connected directly to the battery. Detailed test requirements are in accordance with the ISO 7637-2:2011 and ISO 16750-2:2010 standards. The TPS1HC30-Q1 device is tested and certificated by a third-party organization.

**Table 9-2. ISO 7637-2:2011(E) in 12-V System<sup>(1) (2) (3)</sup>**

Test Item	Test Pulse Severity Level and vs Accordingly		Pulse Duration ( $t_d$ )	Minimum Number of Pulses or Test Time	Burst-Cycle Pulse-Repetition Time		Input Resistance ( $\Omega$ )	Function Performance Status Classification
	Level	Vs/V			MIN	MAX		
1	III	-112	2 ms	500 pulses	0.5 s	e s	10	Status II
2a	III	55	50 $\mu$ s	500 pulses	0.2 s	5 s	2	Status II
2b	IV	10	0.2 to 2 s	10 pulses	0.5 s	5 s	0 to 0.05	Status II
3a	IV	-220	0.1 $\mu$ s	1h	90 ms	100 ms	50	Status II
3b	IV	150	0.1 $\mu$ s	1h	90 ms	100 ms	50	Status II

- (1) Tested both under input low condition and high condition.
- (2) The pulse 2-A voltage is 54-V maximum from VBB with respect to ground. A voltage suppressing mechanism must be used to pass Level III. This test was run with an SMAJ36CA from VBB to ground.
- (3) Status II: The function does not perform as designed during the test, but returns automatically to normal operation after the test.

**Table 9-3. ISO 16750-2:2010(E) Load Dump Test B in 12-V System<sup>(1) (2) (3) (4) (5)</sup>**

Test Item	Test Pulse Severity Level and vs Accordingly		Pulse Duration ( $t_d$ )	Minimum Number of Pulses or Test Time	Burst Cycle, Pulse Repetition Time		Input Resistance ( $\Omega$ )	Function Performance Status Classification
	Level	Vs/V			MIN (s)	MAX (s)		
Test B		35	40 to 400 ms	5 pulses	60	e	0.5 to 4	Status II

- (1) Tested both under input low condition and high condition (DIAG\_EN, EN, and VBB are all classified as inputs).
- (2) Considering the worst test condition, the device is tested without any filter capacitors on VBB and VOUT.
- (3) The GND pin network is a 1-k $\Omega$  resistor in parallel with a diode BAS21-7-F.
- (4) Status II: The function does not perform as designed during the test, but returns automatically to normal operation after the test.
- (5) Select a 39-V external suppressor.

### 9.3 Power Supply Recommendations

The device is qualified for both automotive and industrial applications. The normal power supply connection is a 12-V automotive system. The supply voltage must be within the range specified in the [Recommended Operating Conditions](#).

**Table 9-4. Voltage Operating Ranges**

VBB Voltage Range	Note
3 V to 6 V	Extended lower 12-V automotive battery operation such as cold crank and start-stop. Device is fully functional and protected but some parametrics such as $R_{ON}$ , current sense accuracy, current limit accuracy and timing parameters can deviate from specifications. Check the individual specifications in the Electrical Characteristics to confirm the voltage range it is applicable for.
6 V to 18 V	Nominal 12-V automotive battery voltage range. All parametric specifications apply and the device is fully functional and protected.
18 V to 24 V	Extended upper 12-V automotive battery operation such as double battery. Device is fully functional and protected but some parametrics such as $R_{ON}$ , current sense accuracy, current limit accuracy, and timing parameters can deviate from specifications. Check the individual specifications in the Electrical Characteristics to confirm the voltage range it is applicable for.
35 V	Load dump voltage. Device is operational and lets the pulse pass through without being damaged but does not protect against short circuits.

## 9.4 Layout

### 9.4.1 Layout Guidelines

To prevent thermal shutdown,  $T_J$  must be less than  $150^{\circ}\text{C}$ . If the output current is very high, the power dissipation can be large. The HTSSOP package has good thermal impedance. However, the PCB layout is very important. Good PCB design can optimize heat transfer, which is absolutely essential for the long-term reliability of the device.

- Maximize the copper coverage on the PCB to increase the thermal conductivity of the board. The major heat-flow path from the package to the ambient is through the copper on the PCB. Maximum copper is extremely important when there are not any heat sinks attached to the PCB on the other side of the board opposite the package.
- Add as many thermal vias as possible directly under the package ground pad to optimize the thermal conductivity of the board.
- Plate shut or plug and cap all thermal vias on both sides of the board to prevent solder voids. To ensure reliability and performance, the solder coverage must be at least 85%.

### 9.4.2 Layout Example

#### 9.4.2.1 Without a GND Network

Without a GND network, tie the thermal pad directly to the board GND copper for better thermal performance.

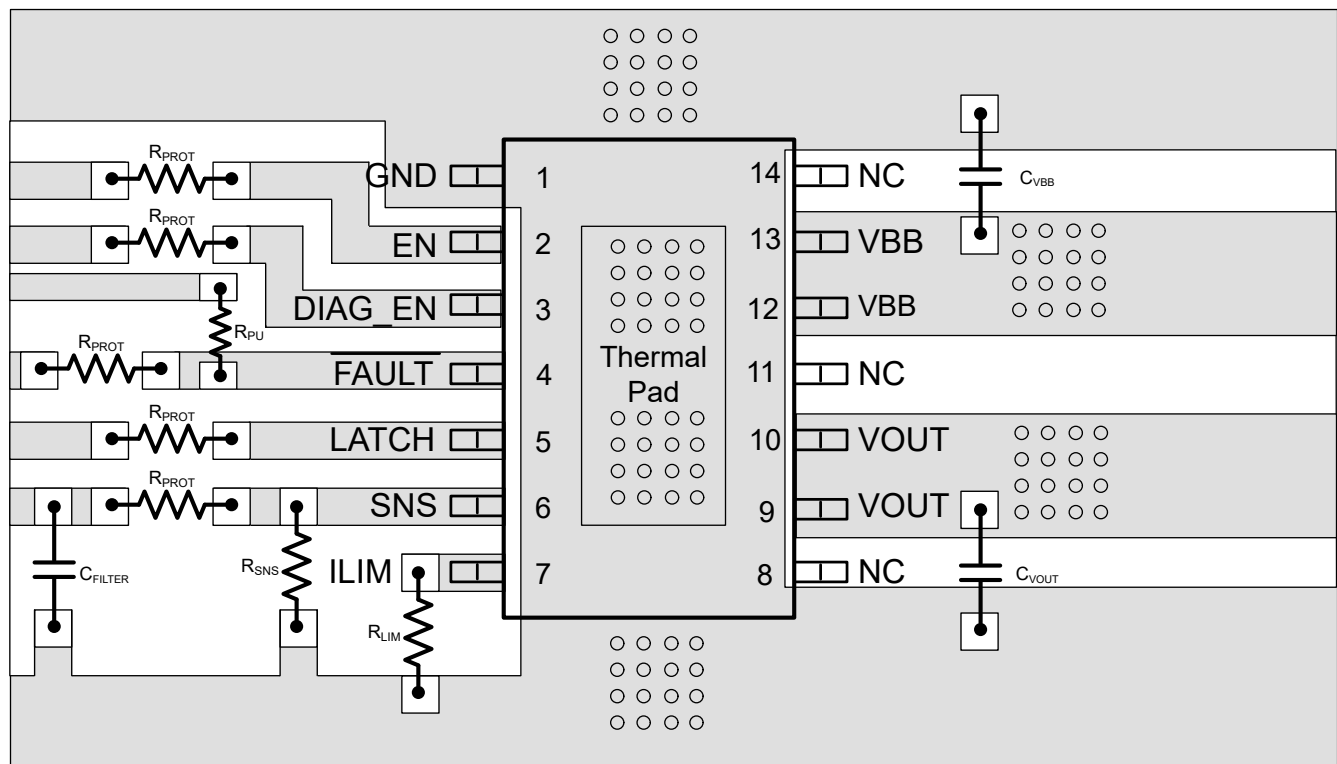

Figure 9-5. Layout without a GND Network

### 9.4.2.2 With a GND Network

With a GND network, tie the thermal pad with one trace through the GND network to the board GND copper.

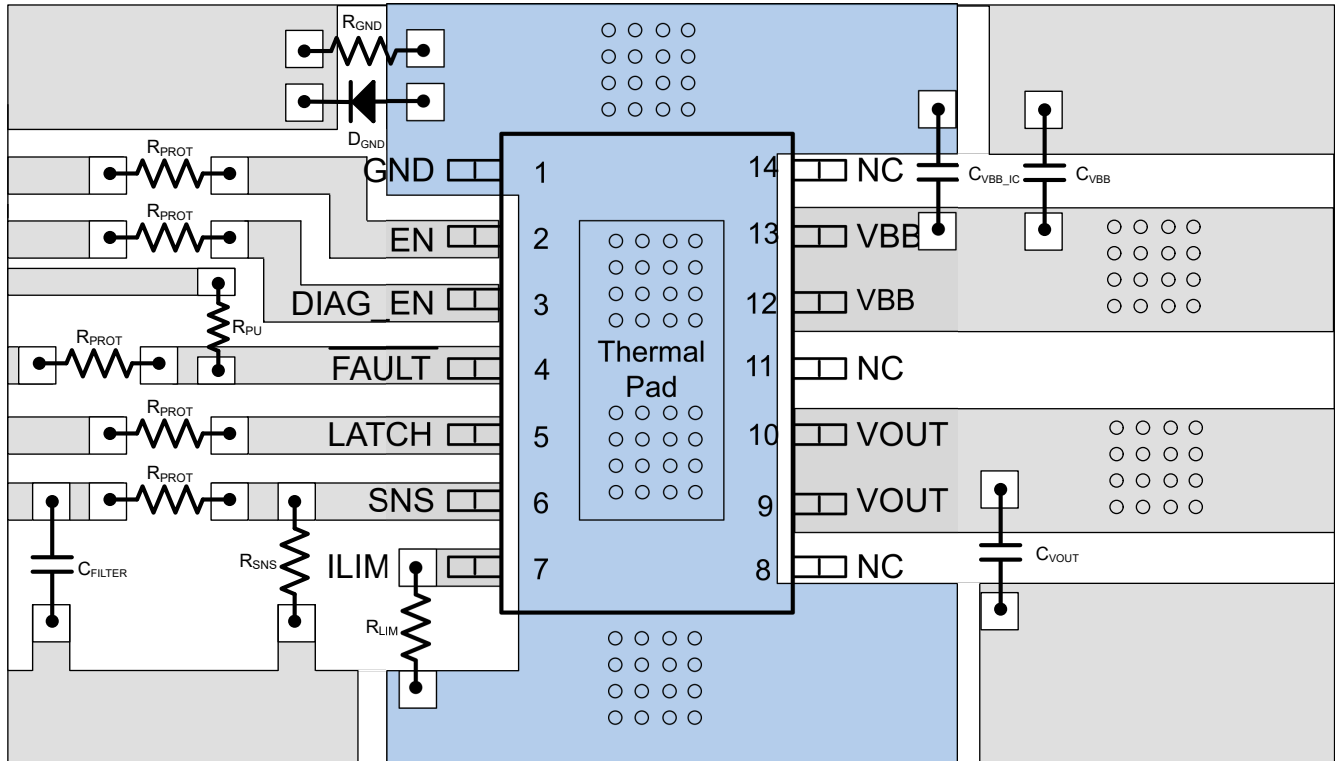

Figure 9-6. Layout with a GND Network

### 9.4.3 Thermal Considerations

This device possesses thermal shutdown ( $T_{ABS}$ ) circuitry as a protection from overheating. For continuous normal operation, the junction temperature must not exceed the thermal-shutdown trip point. If the junction temperature exceeds the thermal-shutdown trip point, the output turns off. When the junction temperature falls below the thermal-shutdown trip point, the output turns on again.

Use the following equation to calculate the power dissipated by the device.

$$P_T = I_{OUT}^2 \times R_{DS(on)} + V_{BB} \times I_{NOM} \quad P_T = I_{OUT}^2 \times R_{DS(on)} + V_S \times I_{nom} \quad (17)$$

where

- $P_T$  = Total power dissipation of the device

After determining the power dissipated by the device, calculate the junction temperature from the ambient temperature and the device thermal impedance.

$$T_J = T_A + R_{\theta JA} \times P_T \quad T_J = T_A + R_{\theta JA} \times P_T \quad (18)$$

For more information, please see the [How to Drive Resistive, Inductive, Capacitive, and Lighting Loads application note](#).

## 10 Device and Documentation Support

### 10.1 Documentation Support

#### 10.1.1 Related Documentation

For related documentation, see the following:

Texas Instruments, [How to Drive Resistive, Inductive, Capacitive, and Lighting Loads application note](#)

### 10.2 Receiving Notification of Documentation Updates

To receive notification of documentation updates, navigate to the device product folder on [ti.com](#). Click on *Subscribe to updates* to register and receive a weekly digest of any product information that has changed. For change details, review the revision history included in any revised document.

### 10.3 Support Resources

[TI E2E™ support forums](#) are an engineer's go-to source for fast, verified answers and design help — straight from the experts. Search existing answers or ask your own question to get the quick design help you need.

Linked content is provided "AS IS" by the respective contributors. They do not constitute TI specifications and do not necessarily reflect TI's views; see TI's [Terms of Use](#).

### 10.4 Trademarks

TI E2E™ is a trademark of Texas Instruments.  
All trademarks are the property of their respective owners.

### 10.5 Electrostatic Discharge Caution



This integrated circuit can be damaged by ESD. Texas Instruments recommends that all integrated circuits be handled with appropriate precautions. Failure to observe proper handling and installation procedures can cause damage.

ESD damage can range from subtle performance degradation to complete device failure. Precision integrated circuits may be more susceptible to damage because very small parametric changes could cause the device not to meet its published specifications.

### 10.6 Glossary

[TI Glossary](#) This glossary lists and explains terms, acronyms, and definitions.

## 11 Mechanical, Packaging, and Orderable Information

The following pages include mechanical, packaging, and orderable information. This information is the most current data available for the designated devices. This data is subject to change without notice and revision of this document. For browser-based versions of this data sheet, refer to the left-hand navigation.



**MECHANICAL DATA**

PWP (R-PDSO-G14)

PowerPAD™ PLASTIC SMALL OUTLINE

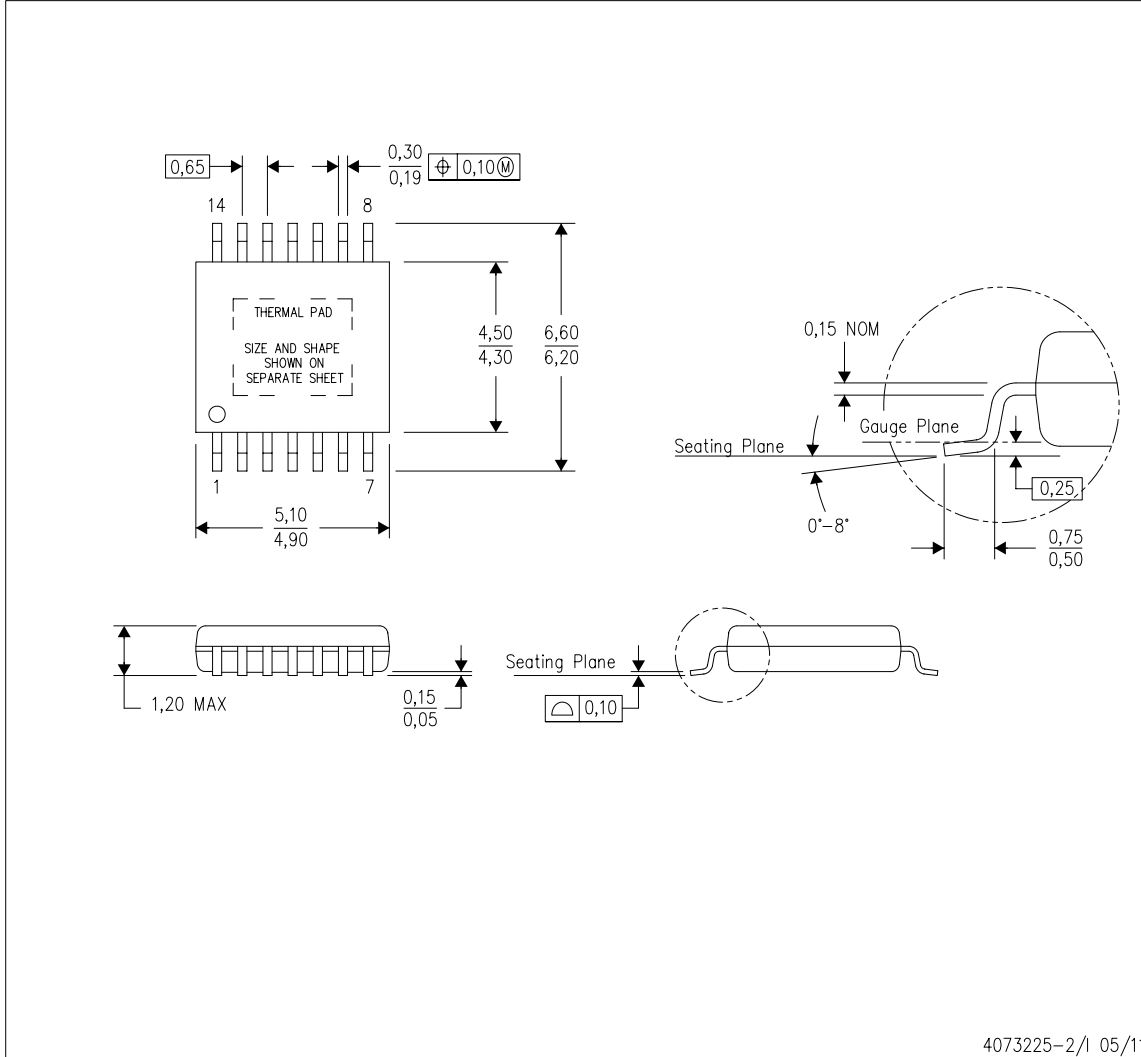

4073225-2/1 05/11

- NOTES:
- A. All linear dimensions are in millimeters.
  - B. This drawing is subject to change without notice.
  - C. Body dimensions do not include mold flash or protrusions. Mold flash and protrusion shall not exceed 0.15 per side.
  - D. This package is designed to be soldered to a thermal pad on the board. Refer to Technical Brief, PowerPad Thermally Enhanced Package, Texas Instruments Literature No. SLMA002 for information regarding recommended board layout. This document is available at [www.ti.com](http://www.ti.com) <<http://www.ti.com>>.
  - E. See the additional figure in the Product Data Sheet for details regarding the exposed thermal pad features and dimensions.
  - F. Falls within JEDEC MO-153

PowerPAD is a trademark of Texas Instruments.

**THERMAL PAD MECHANICAL DATA**

PWP (R-PDSO-G14) PowerPAD™ SMALL PLASTIC OUTLINE

**THERMAL INFORMATION**

This PowerPAD™ package incorporates an exposed thermal pad that is designed to be attached to a printed circuit board (PCB). The thermal pad must be soldered directly to the PCB. After soldering, the PCB can be used as a heatsink. In addition, through the use of thermal vias, the thermal pad can be attached directly to the appropriate copper plane shown in the electrical schematic for the device, or alternatively, can be attached to a special heatsink structure designed into the PCB. This design optimizes the heat transfer from the integrated circuit (IC).

For additional information on the PowerPAD package and how to take advantage of its heat dissipating abilities, refer to Technical Brief, PowerPAD Thermally Enhanced Package, Texas Instruments Literature No. SLMA002 and Application Brief, PowerPAD Made Easy, Texas Instruments Literature No. SLMA004. Both documents are available at [www.ti.com](http://www.ti.com).

The exposed thermal pad dimensions for this package are shown in the following illustration.

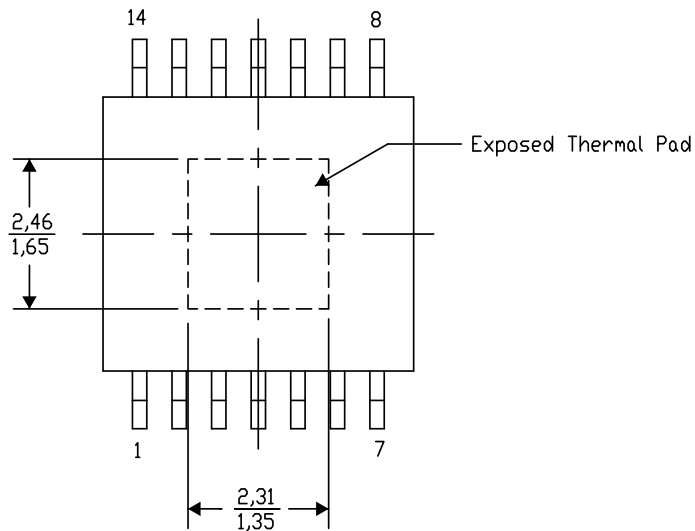

Top View

Exposed Thermal Pad Dimensions

4206332-2/A0 01/16

NOTE: A. All linear dimensions are in millimeters

PowerPAD is a trademark of Texas Instruments

**PACKAGING INFORMATION**

Orderable Device	Status (1)	Package Type	Package Drawing	Pins	Package Qty	Eco Plan (2)	Lead finish/ Ball material (6)	MSL Peak Temp (3)	Op Temp (°C)	Device Marking (4/5)	Samples
PTPS1HC30BQPWPRQ1	ACTIVE	HTSSOP	PWP	14	3000	TBD	Call TI	Call TI	-40 to 125		Samples

(1) The marketing status values are defined as follows:

**ACTIVE:** Product device recommended for new designs.

**LIFEBUY:** TI has announced that the device will be discontinued, and a lifetime-buy period is in effect.

**NRND:** Not recommended for new designs. Device is in production to support existing customers, but TI does not recommend using this part in a new design.

**PREVIEW:** Device has been announced but is not in production. Samples may or may not be available.

**OBSOLETE:** TI has discontinued the production of the device.

(2) **RoHS:** TI defines "RoHS" to mean semiconductor products that are compliant with the current EU RoHS requirements for all 10 RoHS substances, including the requirement that RoHS substance do not exceed 0.1% by weight in homogeneous materials. Where designed to be soldered at high temperatures, "RoHS" products are suitable for use in specified lead-free processes. TI may reference these types of products as "Pb-Free".

**RoHS Exempt:** TI defines "RoHS Exempt" to mean products that contain lead but are compliant with EU RoHS pursuant to a specific EU RoHS exemption.

**Green:** TI defines "Green" to mean the content of Chlorine (Cl) and Bromine (Br) based flame retardants meet JS709B low halogen requirements of <=1000ppm threshold. Antimony trioxide based flame retardants must also meet the <=1000ppm threshold requirement.

(3) MSL, Peak Temp. - The Moisture Sensitivity Level rating according to the JEDEC industry standard classifications, and peak solder temperature.

(4) There may be additional marking, which relates to the logo, the lot trace code information, or the environmental category on the device.

(5) Multiple Device Markings will be inside parentheses. Only one Device Marking contained in parentheses and separated by a "~" will appear on a device. If a line is indented then it is a continuation of the previous line and the two combined represent the entire Device Marking for that device.

(6) Lead finish/Ball material - Orderable Devices may have multiple material finish options. Finish options are separated by a vertical ruled line. Lead finish/Ball material values may wrap to two lines if the finish value exceeds the maximum column width.

**Important Information and Disclaimer:** The information provided on this page represents TI's knowledge and belief as of the date that it is provided. TI bases its knowledge and belief on information provided by third parties, and makes no representation or warranty as to the accuracy of such information. Efforts are underway to better integrate information from third parties. TI has taken and continues to take reasonable steps to provide representative and accurate information but may not have conducted destructive testing or chemical analysis on incoming materials and chemicals. TI and TI suppliers consider certain information to be proprietary, and thus CAS numbers and other limited information may not be available for release.

In no event shall TI's liability arising out of such information exceed the total purchase price of the TI part(s) at issue in this document sold by TI to Customer on an annual basis.

## GENERIC PACKAGE VIEW

**PWP 14**

**PowerPAD TSSOP - 1.2 mm max height**

4.4 x 5.0, 0.65 mm pitch

PLASTIC SMALL OUTLINE

This image is a representation of the package family, actual package may vary.  
Refer to the product data sheet for package details.

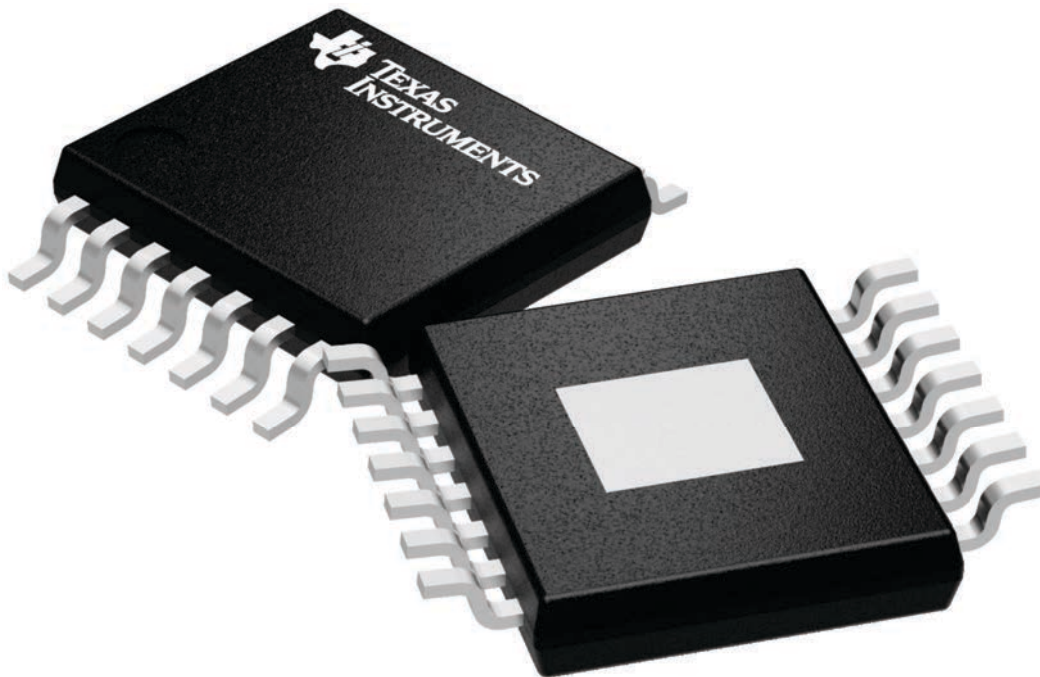

4224995/A

## IMPORTANT NOTICE AND DISCLAIMER

TI PROVIDES TECHNICAL AND RELIABILITY DATA (INCLUDING DATA SHEETS), DESIGN RESOURCES (INCLUDING REFERENCE DESIGNS), APPLICATION OR OTHER DESIGN ADVICE, WEB TOOLS, SAFETY INFORMATION, AND OTHER RESOURCES "AS IS" AND WITH ALL FAULTS, AND DISCLAIMS ALL WARRANTIES, EXPRESS AND IMPLIED, INCLUDING WITHOUT LIMITATION ANY IMPLIED WARRANTIES OF MERCHANTABILITY, FITNESS FOR A PARTICULAR PURPOSE OR NON-INFRINGEMENT OF THIRD PARTY INTELLECTUAL PROPERTY RIGHTS.

These resources are intended for skilled developers designing with TI products. You are solely responsible for (1) selecting the appropriate TI products for your application, (2) designing, validating and testing your application, and (3) ensuring your application meets applicable standards, and any other safety, security, regulatory or other requirements.

These resources are subject to change without notice. TI grants you permission to use these resources only for development of an application that uses the TI products described in the resource. Other reproduction and display of these resources is prohibited. No license is granted to any other TI intellectual property right or to any third party intellectual property right. TI disclaims responsibility for, and you will fully indemnify TI and its representatives against, any claims, damages, costs, losses, and liabilities arising out of your use of these resources.

TI's products are provided subject to [TI's Terms of Sale](#) or other applicable terms available either on [ti.com](http://ti.com) or provided in conjunction with such TI products. TI's provision of these resources does not expand or otherwise alter TI's applicable warranties or warranty disclaimers for TI products.

TI objects to and rejects any additional or different terms you may have proposed.

Mailing Address: Texas Instruments, Post Office Box 655303, Dallas, Texas 75265  
Copyright © 2022, Texas Instruments Incorporated