

Demystifying high-voltage power electronics for solar inverters



Nagarajan Sridhar
*Strategic Marketing Manager,
SiC and Smart Isolated Drivers
Texas Instruments*

The movement toward a clean and a sustainable grid is gaining a lot of momentum through advances in distributed energy resources, namely photovoltaic (PV) or solar power generation. Increased efficiency, reduced cost, and reliability are three areas where renewable-energy systems can achieve grid parity.

One of the key subsystems in PV generation is the inverter. Advancements in high-voltage power electronics are resulting in more intelligent, more lossless and smaller PV inverters.

The goal of this paper is to give an overview of the inverter, highlighting the benefits and advancements made in power electronics that have affected PV inverter technology – particularly wide-bandgap solutions such as silicon carbide (SiC) and gallium nitride (GaN).

Power conditioning in PV systems

PV panels made up of cells, connected in series or parallel, represent the front end of a PV ecosystem. These cells convert sunlight to electrical energy at typical efficiencies from 10% to 30%. The power extracted from the panels is DC and needs to be converted to AC, as most of the loads receive power from AC electricity distribution (the electric grid). Conversion from DC to AC power happens in the back end of the PV chain, in the inverter.

To ensure the stability of the power supply, PV generation systems are coupled with large-capacity energy storage to meet peak power loads. This is called a grid tied with an energy storage/ battery backup system. This configuration, while complicated, is the trend in modern PV systems. The solar panel uses the charge controller to charge the battery. Typically, energy in the batteries is used either for peak power demand or for emergency backup. If the batteries are fully charged and the demand requires energy exceeding what the PV panels can provide, electricity flows into the grid from the batteries through the inverter.

On the other hand, if the panels produce excess electricity and the batteries are fully charged, then the electricity flows directly into the grid through the inverter. Inverters used in such systems are called grid direct inverters.

Function of the grid direct inverter

Synchronization with the grid is one of the key functions of a grid direct inverter. The inverter needs to generate a sinusoidal AC waveform at a fixed level from the PV panels, which has varying voltages depending on the sun's irradiance, weather conditions and other factors. The output voltage and frequency need to be at a certain level, outside of which the inverter will be unable to connect to the grid.

For example, grid direct inverters for residential systems in the U.S. usually have an output voltage of either 120V or 240VAC with an output frequency of 60Hz. Such stringent requirements are not necessary in inverters for stand-alone systems (where the PV panels connect not to the grid but to DC or AC loads). However, such systems are far less common than grid-tied configurations.

In addition to grid synchronization, the grid direct inverter performs other tasks, such as maximum power point tracking (MPPT), monitoring, protection and communication.

Key inverter components

Regardless of configuration, inverters today are built using high-voltage power electronic components.

The key components of an inverter are:

- Power semiconductor switches: insulated gate bipolar transistors (IGBTs), silicon metal-oxide semiconductor field-effect transistors (Si MOSFETs), SiC and GaN
- Gate drivers
- A controller for MPPT and charging energy storage solutions (batteries) – digital or analog

Keeping in mind high efficiency, high reliability and low cost as the key priorities to achieve grid parity, it is imperative to make the right component choices depending on inverter requirements such as power level and rail voltage. Power losses in semiconductor switches and gate drivers are directly related to efficiency. Keeping losses close to zero in passive filtering elements such as capacitors, inductors and transformers is also critical.

Inverter configurations

Figure 1 shows three different inverter configurations. Each one depends on the power levels. A micro-inverter is a low-power configuration ranging from 50W to 400W. A medium power configuration between 1kW and 20kW is called a string inverter, while a high-power configuration greater than 20kW is called a central inverter.

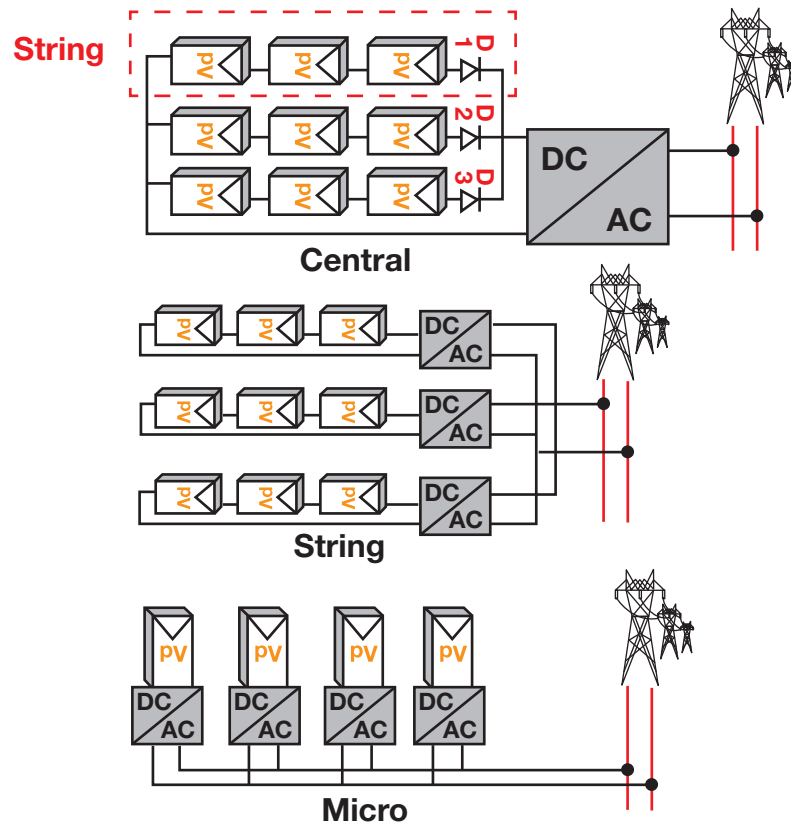

Figure 1. Different inverter configurations.

All inverter configurations follow the same methodology for power conversion and similar requirements: an integrated solution to lower system/overall cost, high efficiency, small size and increased lifetime (20 years). There are also variations in MPPT and power-conversion topology to maximize inverter efficiency. The choice of power electronics components varies by configuration as well.

Here are the main features of the three inverter configurations:

- Micro inverter:
 - Integrates a separate inverter and MPP tracker in each solar panel
 - No DC cabling, but requires extensive AC cabling
 - More efficient than string inverters
 - Only economical for small systems
- String inverter:
 - Solar panels are connected serially (strings)
 - Uses multiple inverters for example, one per string
 - Good efficiency, because every string can operate in its maximum power point
- Central inverter:
 - Several strings (serially coupled solar panels) are connected in parallel
 - Uses only a single inverter for a set of solar panels
 - Special diodes are required to enable different string voltages, but diodes cause losses
 - Not all solar panels can be driven to their maximum power point

Among the three configurations, the string inverter is by the far the most popular. String inverters are very scalable and economical for both residential and commercial applications.

Inverter stages

Fundamentally, the function of an inverter is to convert DC to AC in addition to monitoring MPPT and sinusoidal wave shaping. For a grid direct inverter, the input voltage usually needs to be above the output AC voltage (grid voltage). For example, generating a sinusoidal waveform of 230VAC requires an input voltage higher than 400VDC. The problem is that PV modules often deliver lower voltages than what the digital-to-analog converter requires. The way to resolve this is to use a boost DC/DC converter as the first stage [1].

DC/DC stage

In order to maximize the performance of the PV panels, the front end of the inverter is a DC/DC stage where a digital controller performs MPPT. The most common topology is a non-isolated DC/DC boost converter. The MPPT algorithm ensures that maximum power is drawn accurately and quickly when there is varying irradiance. The inverter also ensures an appropriate grid-compliant voltage.

The inverter configuration dictates finer control of MPPT. Micro inverters connected at the back of each solar panel can achieve the finest control and enable MPPT at a modular level. The less granular solution is a string inverter connected to a series of modules. This inverter has a sophisticated controller (usually digital) that performs similar MPPT. Although less granular, string inverter solutions usually have the largest cost advantage, a key metric in the solar industry.

The digital controller is also responsible for pulse-width modulation (PWM) in the primary side. PWM takes place using gate drivers. Depending on the inverter configuration, isolation may or may not be needed.

In all inverter configurations, the DC/DC stage uses high switching frequencies. However, the rail or DC link voltage could vary from as low as 200V to greater than 1kV depending on the inverter configuration. For voltages around 600V or below, Si MOSFETs are a good fit for DC/DC conversion.

Since reduced size is becoming a trend, especially in string and micro inverters, GaN is being adopted in micro inverters because of its ability to switch at frequencies close to 1MHz. On the other hand, for voltages higher than 600V, SiC MOSFETs are

becoming more popular. Depending on the topology, single, dual or half-bridge MOSFET drivers are used with fast propagation delays and high drive currents.

DC/AC stage

Figure 2 shows the block diagram of a starting inverter with the DC/AC stage marked in red. The rail voltages are around 600V to 1,200V, particularly in string and central inverters, making IGBTs the preferred choice for switching. The gate drivers needed to switch these IGBTs require advanced features such as desaturation, short-circuit current protection, Miller clamping and negative voltage handling. In addition, these drivers need to be galvanically isolated. This is explained in a later section.

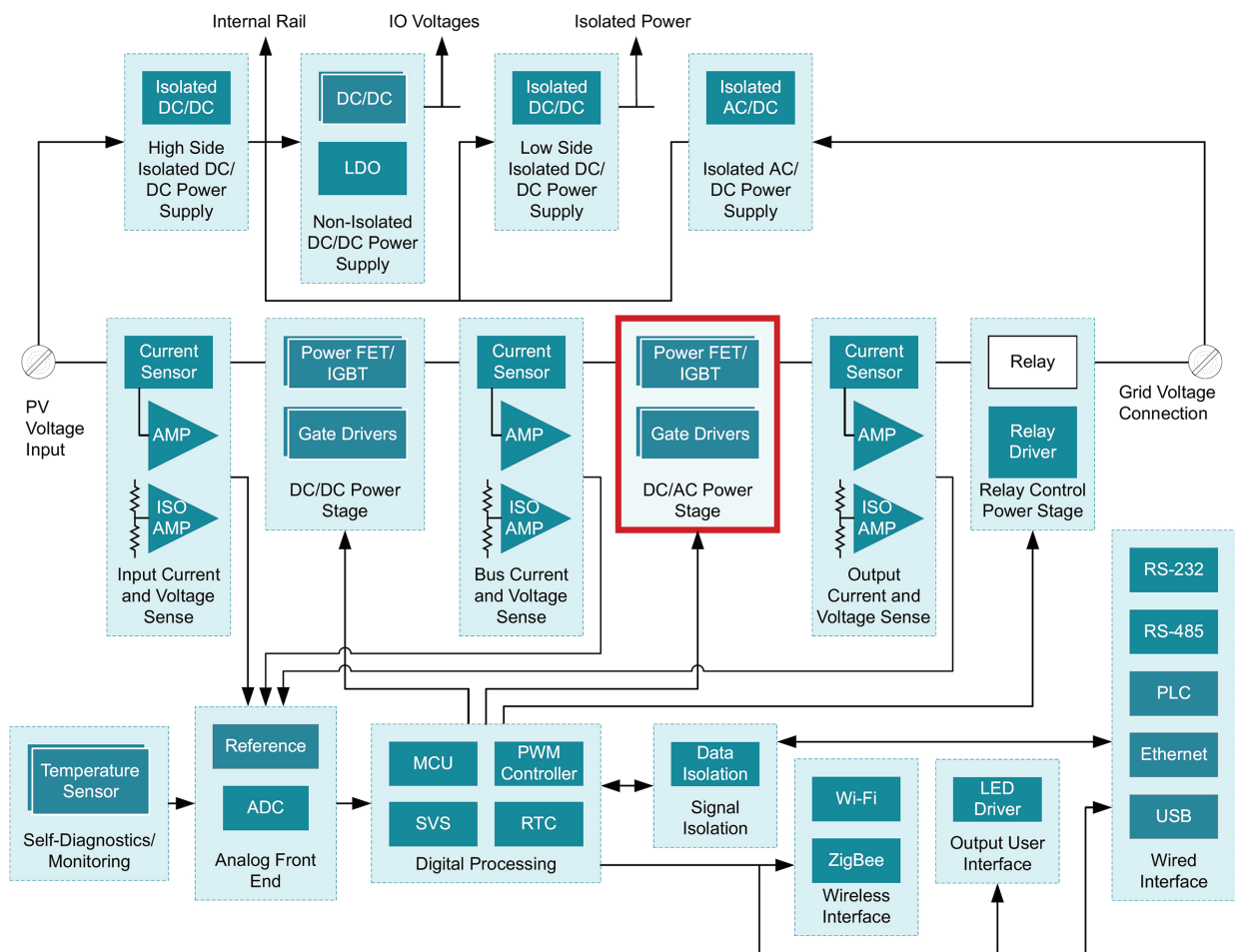

Figure 2. . Block diagram of a string inverter.

Why is SiC the right choice?

As mentioned earlier, there is a strong push toward higher system efficiency, longer lifetime and compact solutions. Unfortunately, MOSFETs and IGBTs are approaching their theoretical limits. IGBTs currently used in high-voltage (>650V)/high-power applications are already being stretched to their absolute limit at voltages above 1kV.

SiC FETs have superior material properties such as low on-resistance, high thermal conductivity, high breakdown voltage and high saturation velocity compared to silicon. All of these characteristics result in an efficient, robust and compact system with reduced cooling needs. SiC FETs are built into high-power DC/AC stages, either as several FETs connected in parallel or as a module.

SiC cannot do it alone

SiC switches need to be turned on and off for efficient power transfer through a gate driver as dictated by the controller for any given topology. The gate driver acts as an interface between the

controller and the power device. Given the superior characteristics of SiC FETs, defining the requirements for gate drivers becomes very critical [3].

One unique feature for a SiC gate driver is fast overcurrent protection, versus desaturation for an IGBT gate driver. For the same rated current and voltage, an IGBT reaches the active region for significantly lower collector-emitter voltage (VCE) (typically 9V) compared to a SiC MOSFET. IGBT self-limits the current increase. In the case of SiC, the drain current (ID) continues to increase with the increase in the drain-to-source voltage (VDS), eventually resulting in faster breakdown. It is therefore critical for a SiC gate driver to have fast protection and therefore fast fault reporting, typically 400ns [3].

The gate voltage must have high dv/dt to accommodate the high switching speeds of SiC, implying the need for a low impedance driver for robust operation. Since SiC and IGBTs are used in high-voltage/high-power applications, almost all of the gate drivers are isolated. **Table 1** is a comparative analysis among Si MOSFET, IGBT and SiC gate drivers.

Power Switch	MOSFET	IGBT	SiC
Switching frequencies	High (>20kHz)	Low to medium (5-20kHz)	High (>50 kHz)
Basic protection	No	Yes – Desaturation, Miller Clamping	Yes – Current sense, Miller Clamping
Max Vdd (power supply)	20V	30V	30V
Vdd range	0 to 20V	-10 to 20V	-5 to 25V
Operating Vdd	10 to 12V	12 to 15V	15 to 18V
UVLO	8V	12V	12 to 15V
CMTI	50 to 100V/ns	<50V/ns	>100V/ns
Propagation delay	Smaller the better (<50ns)	High (not critical)	Smaller the better (<50ns)
Rail voltage	Up to 650V	>650V	>650V
Typical applications	Power supplies – Server, datacom, telecom, factory automation, onboard and offboard chargers, solar u-inverters and string inverters (<3kW), 400-12V DCDC - Auto	Motor drives (AC machines), UPS, solar central and string power inverters (>3kW), traction inverters for auto	PFC – Power supplies, Solar inverters, DCDC for EV/HEV and traction inverters for EV, motor drives, railways

Table 1. Comparison of SiC to MOSFET and IGBT iso drivers.

In addition, all gate drivers and controllers need to power up at the highest level of efficiency using isolated power supplies. These supplies are usually flyback converters or general-purpose PWM converters.

Need for isolation

Galvanic isolation is a technique to isolate functional sections of electrical systems to prevent current flow between them. This prevents no direct current or uncontrolled transient current from flowing in between the two. However, data and energy need to flow through this galvanic isolation barrier. This barrier is based on optical, magnetic or capacitive isolation technologies. Of these, capacitive and magnetic isolation allow data to be transmitted through the barrier digitally. Capacitive isolation, like magnetic isolation has digital circuits for encoding and decoding the incoming signals to pass through the isolation barrier. Also fundamentally capacitors do not pass DC signals and can only pass AC signals. That makes it inherently the right choice for isolation. Finally, they are not susceptible to magnetic noise while maintaining high data rates and keep the power consumption low.

Particularly for SiC power switches, capacitive isolation is the preferred choice for SiC gate drivers due to its high data rate and high noise immunity (also called common mode transient immunity) above 150V/ns.

In general, there are two types of galvanic isolation, basic and reinforced. Choice of the type is dictated by the standards and certification requirements for the inverter in the region it is sold.

Summary

TI offers several isolated gate drivers for power switches, including the [ISO545x/585x](#), [UCC21521C](#), [UCC2122x](#) and [UCC53xx](#) for efficient and reliable solar power conversion. Digital controllers such as TI's Piccolo™ and Delfino™ families from the C2000™ platform of real-time controllers are available for efficient PWM and MPPT control along with analog controllers such as the [UCC28C45](#) and [UC2845](#) for auxiliary power supplies.

References

1. Kjaer, Soren B., John K. Pedersen and F. Blaabjerg “[Power inverter topologies for photovoltaic modules – A review](#)” Conference Record of the Industry Applications Conference, 37th IAS Annual Meeting 788:2, February 2002.
2. Yuan, Xibo “Derivation of Voltage Source Multilevel Converter Topologies” IEEE transactions on Industrial Electronics, VOL. 64, NO. 2, February 2017.
3. Guo. Suxaun “Understanding the Short Circuit Protection for Silicon Carbide MOSFETs” TI Tech Note [SLUA863](#), January 2018.

Important Notice: The products and services of Texas Instruments Incorporated and its subsidiaries described herein are sold subject to TI's standard terms and conditions of sale. Customers are advised to obtain the most current and complete information about TI products and services before placing orders. TI assumes no liability for applications assistance, customer's applications or product designs, software performance, or infringement of patents. The publication of information regarding any other company's products or services does not constitute TI's approval, warranty or endorsement thereof.

The platform bar, C2000, Delfino and Piccolo are trademarks of Texas Instruments.
All other trademarks are the property of their respective owners.

IMPORTANT NOTICE FOR TI DESIGN INFORMATION AND RESOURCES

Texas Instruments Incorporated ("TI") technical, application or other design advice, services or information, including, but not limited to, reference designs and materials relating to evaluation modules, (collectively, "TI Resources") are intended to assist designers who are developing applications that incorporate TI products; by downloading, accessing or using any particular TI Resource in any way, you (individually or, if you are acting on behalf of a company, your company) agree to use it solely for this purpose and subject to the terms of this Notice.

TI's provision of TI Resources does not expand or otherwise alter TI's applicable published warranties or warranty disclaimers for TI products, and no additional obligations or liabilities arise from TI providing such TI Resources. TI reserves the right to make corrections, enhancements, improvements and other changes to its TI Resources.

You understand and agree that you remain responsible for using your independent analysis, evaluation and judgment in designing your applications and that you have full and exclusive responsibility to assure the safety of your applications and compliance of your applications (and of all TI products used in or for your applications) with all applicable regulations, laws and other applicable requirements. You represent that, with respect to your applications, you have all the necessary expertise to create and implement safeguards that (1) anticipate dangerous consequences of failures, (2) monitor failures and their consequences, and (3) lessen the likelihood of failures that might cause harm and take appropriate actions. You agree that prior to using or distributing any applications that include TI products, you will thoroughly test such applications and the functionality of such TI products as used in such applications. TI has not conducted any testing other than that specifically described in the published documentation for a particular TI Resource.

You are authorized to use, copy and modify any individual TI Resource only in connection with the development of applications that include the TI product(s) identified in such TI Resource. NO OTHER LICENSE, EXPRESS OR IMPLIED, BY ESTOPPEL OR OTHERWISE TO ANY OTHER TI INTELLECTUAL PROPERTY RIGHT, AND NO LICENSE TO ANY TECHNOLOGY OR INTELLECTUAL PROPERTY RIGHT OF TI OR ANY THIRD PARTY IS GRANTED HEREIN, including but not limited to any patent right, copyright, mask work right, or other intellectual property right relating to any combination, machine, or process in which TI products or services are used. Information regarding or referencing third-party products or services does not constitute a license to use such products or services, or a warranty or endorsement thereof. Use of TI Resources may require a license from a third party under the patents or other intellectual property of the third party, or a license from TI under the patents or other intellectual property of TI.

TI RESOURCES ARE PROVIDED "AS IS" AND WITH ALL FAULTS. TI DISCLAIMS ALL OTHER WARRANTIES OR REPRESENTATIONS, EXPRESS OR IMPLIED, REGARDING TI RESOURCES OR USE THEREOF, INCLUDING BUT NOT LIMITED TO ACCURACY OR COMPLETENESS, TITLE, ANY EPIDEMIC FAILURE WARRANTY AND ANY IMPLIED WARRANTIES OF MERCHANTABILITY, FITNESS FOR A PARTICULAR PURPOSE, AND NON-INFRINGEMENT OF ANY THIRD PARTY INTELLECTUAL PROPERTY RIGHTS.

TI SHALL NOT BE LIABLE FOR AND SHALL NOT DEFEND OR INDEMNIFY YOU AGAINST ANY CLAIM, INCLUDING BUT NOT LIMITED TO ANY INFRINGEMENT CLAIM THAT RELATES TO OR IS BASED ON ANY COMBINATION OF PRODUCTS EVEN IF DESCRIBED IN TI RESOURCES OR OTHERWISE. IN NO EVENT SHALL TI BE LIABLE FOR ANY ACTUAL, DIRECT, SPECIAL, COLLATERAL, INDIRECT, PUNITIVE, INCIDENTAL, CONSEQUENTIAL OR EXEMPLARY DAMAGES IN CONNECTION WITH OR ARISING OUT OF TI RESOURCES OR USE THEREOF, AND REGARDLESS OF WHETHER TI HAS BEEN ADVISED OF THE POSSIBILITY OF SUCH DAMAGES.

You agree to fully indemnify TI and its representatives against any damages, costs, losses, and/or liabilities arising out of your non-compliance with the terms and provisions of this Notice.

This Notice applies to TI Resources. Additional terms apply to the use and purchase of certain types of materials, TI products and services. These include; without limitation, TI's standard terms for semiconductor products (<http://www.ti.com/sc/docs/stdterms.htm>), [evaluation modules](#), and [samples](http://www.ti.com/sc/docs/sampterm.htm) (<http://www.ti.com/sc/docs/sampterm.htm>).

Mailing Address: Texas Instruments, Post Office Box 655303, Dallas, Texas 75265
Copyright © 2018, Texas Instruments Incorporated