

Using a Single-Output Gate-Driver for High-Side or Low-Side Drive

John Stevens

High Performance Isolated Power

ABSTRACT

In many isolated power-supply applications, power MOSFETs are often arranged in some form of bridge configuration for optimization of the power switches and power transformer for greater efficiency. These bridge configurations create two classifications of switches: high-side (HS) and low-side (LS). Dedicated HS and LS gate-driver ICs, such as the UCC277xx, UCC272xx and LM510x families, offer an output for HS switches as well as an output for LS switches in a single IC.

In contrast, some applications see great benefit from using single-output gate drivers such as the UCC2753x or the isolated UCC53xx families instead of combining HS and LS into one half bridge driver. Single output drivers can be located closer to the power switches, enabling greater layout flexibility and fewer parasitics, leading to optimal switching performance.

Contents

1	Introduction	1
2	Methods For High-Side Drive	3
3	Conclusion	7

List of Figures

1	Full-Bridge Powerstage With both High-Side and Low-Side Primary MOSFETs	2
2	High-Side Gate-Drive Transformer	3
3	High-Side Bootstrap Circuit Using Capacitor-Based Signal Isolation	4
4	High-Side Isolated Driver and Bias Supply	5
5	Isolated Drivers Using High-Side Bootstrap Circuit	6
6	Isolated Drivers Using Isolated Bias Supply	7

List of Tables

Trademarks

All trademarks are the property of their respective owners.

1 Introduction

HS switches refer to Q1 and Q2 in [Figure 1](#). These switches have a source connection that is floating and the voltage on this reference changes during the switching cycle. Q3 and Q4 are considered LS switches as their source reference connection is tied to input ground and does not change voltage during the switching period. Power is delivered to V_{out} when Q1 and Q3 are on at once, or when Q2 and Q4 are on together. For our circuit examples in [Section 2](#), we will focus only on the bridge portion using Q1 and Q3.

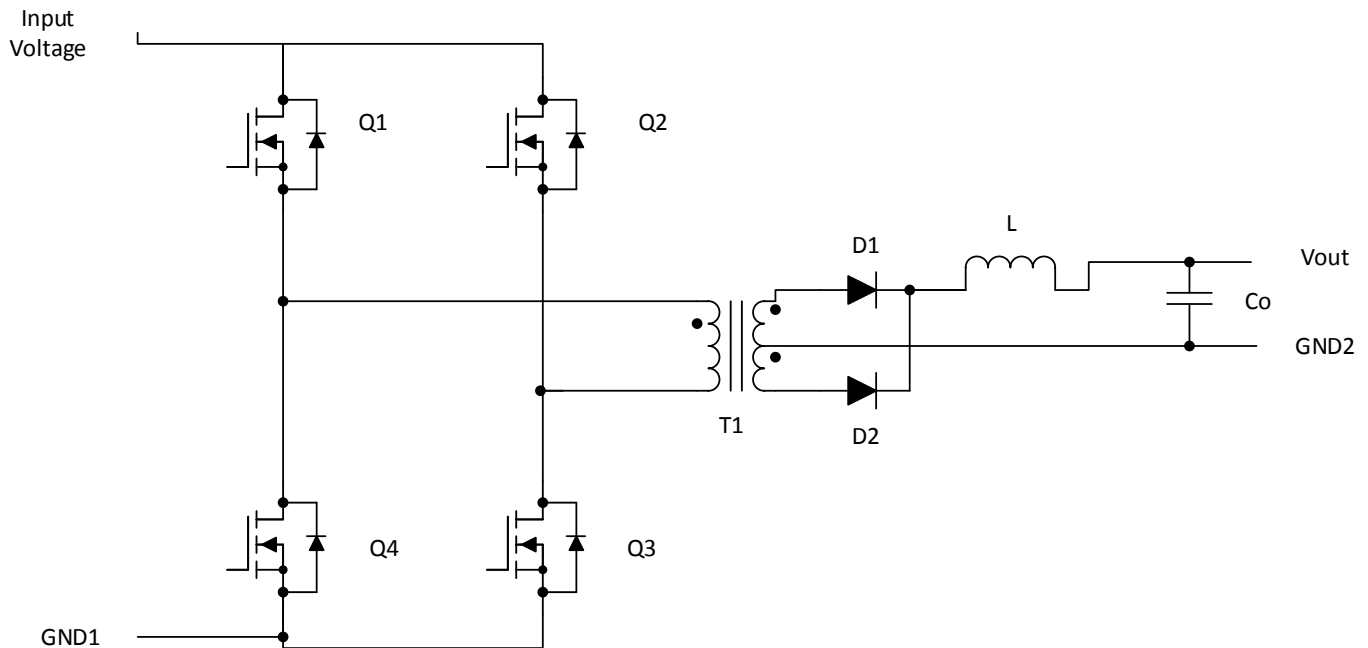

Figure 1. Full-Bridge Powerstage With both High-Side and Low-Side Primary MOSFETs

To properly turn-on these switches in high-power applications, gate-drive ICs are often required. To properly drive a LS power switch, it is usually simple enough in that the output of the gate driver can be tied directly to the gate of the switch with the GND of the Driver IC tied to the source of the switch. To drive a HS switch, however, a few more considerations must be made:

1. For the **gate driver output signal** itself, a level-shifter or isolated signal transceiver such as a digital isolator is needed to ensure the gate maintains the proper voltage above the source to properly turn-on the HS switch. As the source of Q1 (GND of gate driver) rises during Q1 turn-on, the driver needs its reference voltage to follow the Q1 source closely and maintain the difference between the signal voltage and the reference. Further, the GND of this driver needs to be isolated from the controller ground because the Q1 source moves between 0 V and some higher voltage such as 400 V.
2. The HS gate driver also needs some sort of **bias supply** that can float and maintain the proper turn-on bias when the source rises to the input voltage. Otherwise, the gate driver would shutdown when the Q1 source voltage increases. This is usually accomplished by using a bootstrap circuit, an isolated bias supply, or using gate-drive transformers to isolate the gate driver from the switch-node reference.

2 Methods For High-Side Drive

2.1 Gate-Drive Transformer Solution

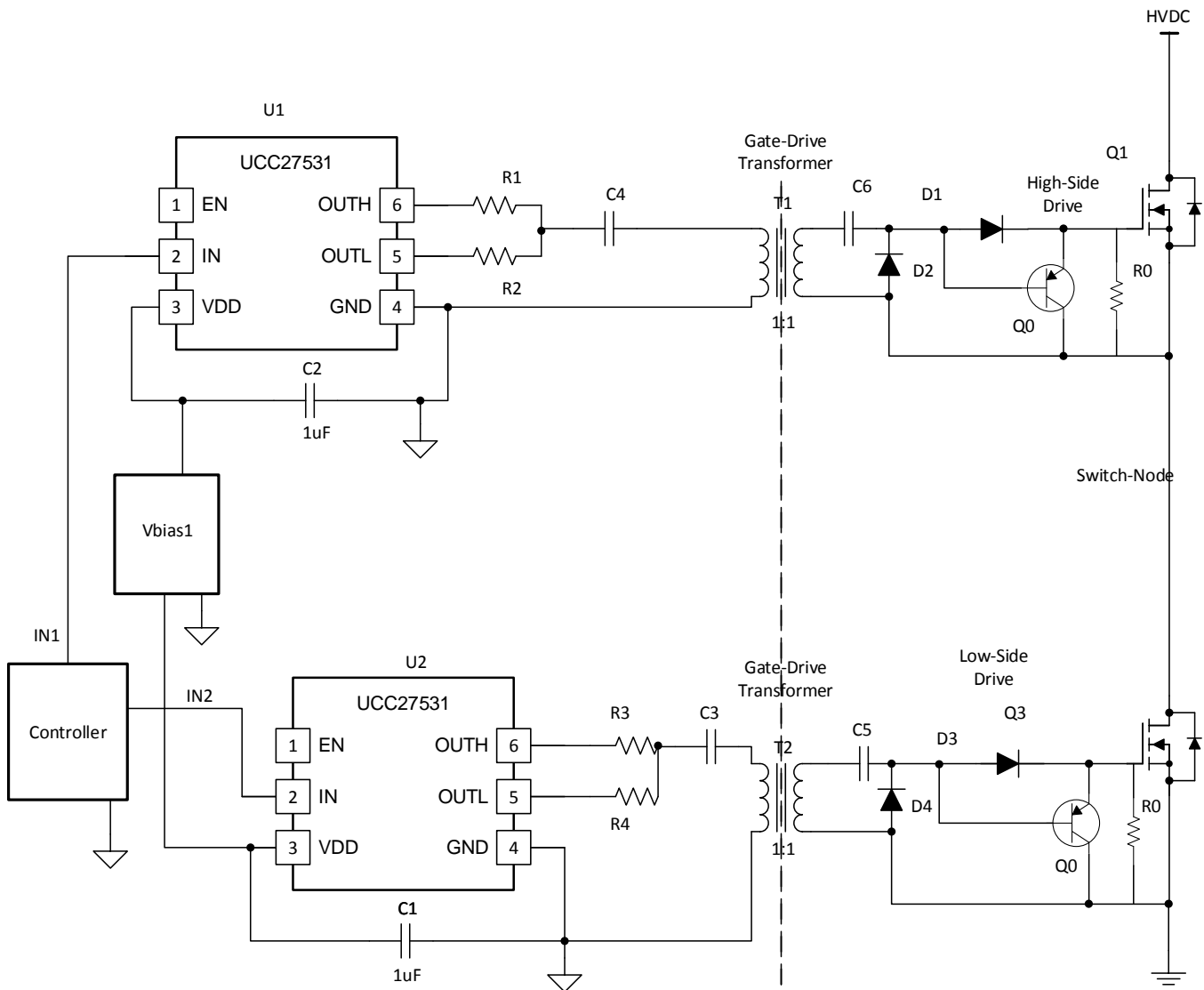

Figure 2. High-Side Gate-Drive Transformer

Signal Isolation

The output signals of U1 are isolated in Figure 2 with the use of T1. The transformer allows the gate signal to Q1 to have a floating reference that can move as the switch-node moves in voltage. DC blocking capacitors like C4 and C6 are added, as well as rectifier D1, and D2 to add offset to C6 preventing imbalance in the transformer. Q0 and R0 are used for turning off the power switch.

High-Side Bias

In Figure 2, an isolated or bootstrap supply is not needed. In this configuration the gate drivers are referenced to the same ground as the controller and Vbias1. Therefore, bias voltage can be directly supplied by Vbias1.

2.2 Bootstrap Bias Supply with Capacitive Signal Isolation Solution

Signal Isolation

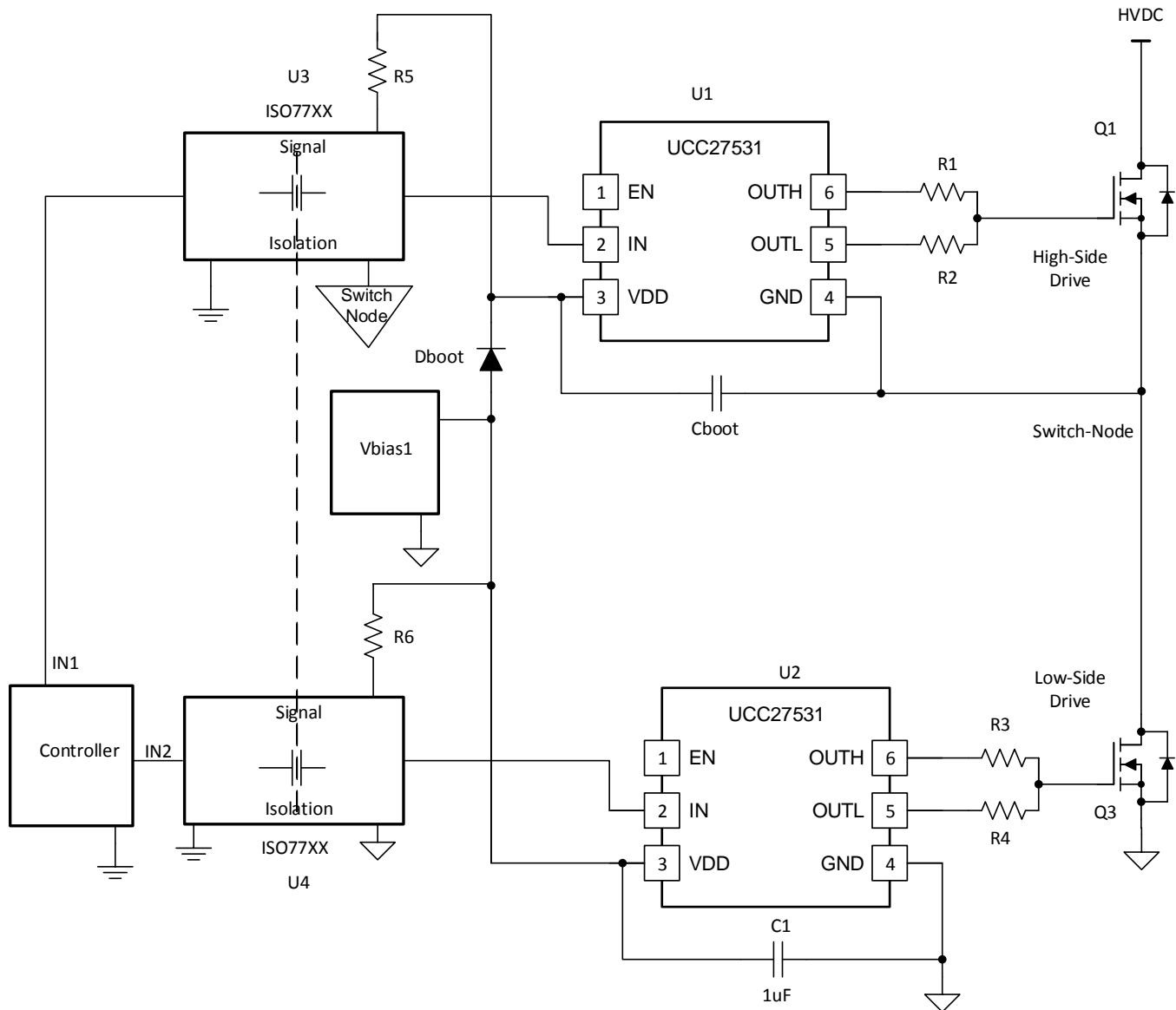

Figure 3. High-Side Bootstrap Circuit Using Capacitor-Based Signal Isolation

In [Figure 2](#), the input to U1 is isolated using U3. U3 is capacitive signal isolator ISO77xx. Capacitive-based isolators can signal properly even with large common-mode ground slew-rates, they are more stable over life and temperature compared to optocouplers, and they do not have the duty cycle limitations of gate-drive transformers.

High-Side Bias

In [Figure 2](#), Dboot and Cboot are used as a bootstrap circuit to bias U1 properly when Q1 is turned on. When Q1 is off, Dboot is forward biased and U1 is supplied directly from Vbias1 while Cboot is charged. When Q1 turns on, the switch-node voltage increases to HVDC, Dboot is reverse-biased and protecting Vbias1, and U1 is powered as Cboot empties its charge into the VDD pin of U1. This charge from Cboot must be adequate to keep U1 on throughout the entire time that Q1 is on. Sizing of Dboot and Cboot are beyond the scope of this article. In the UCC27712 datasheet, refer to for selecting Cboot and for selecting Dboot.

2.3 Isolated Bias Supply With Isolated High-Side Gate-Driver Solution

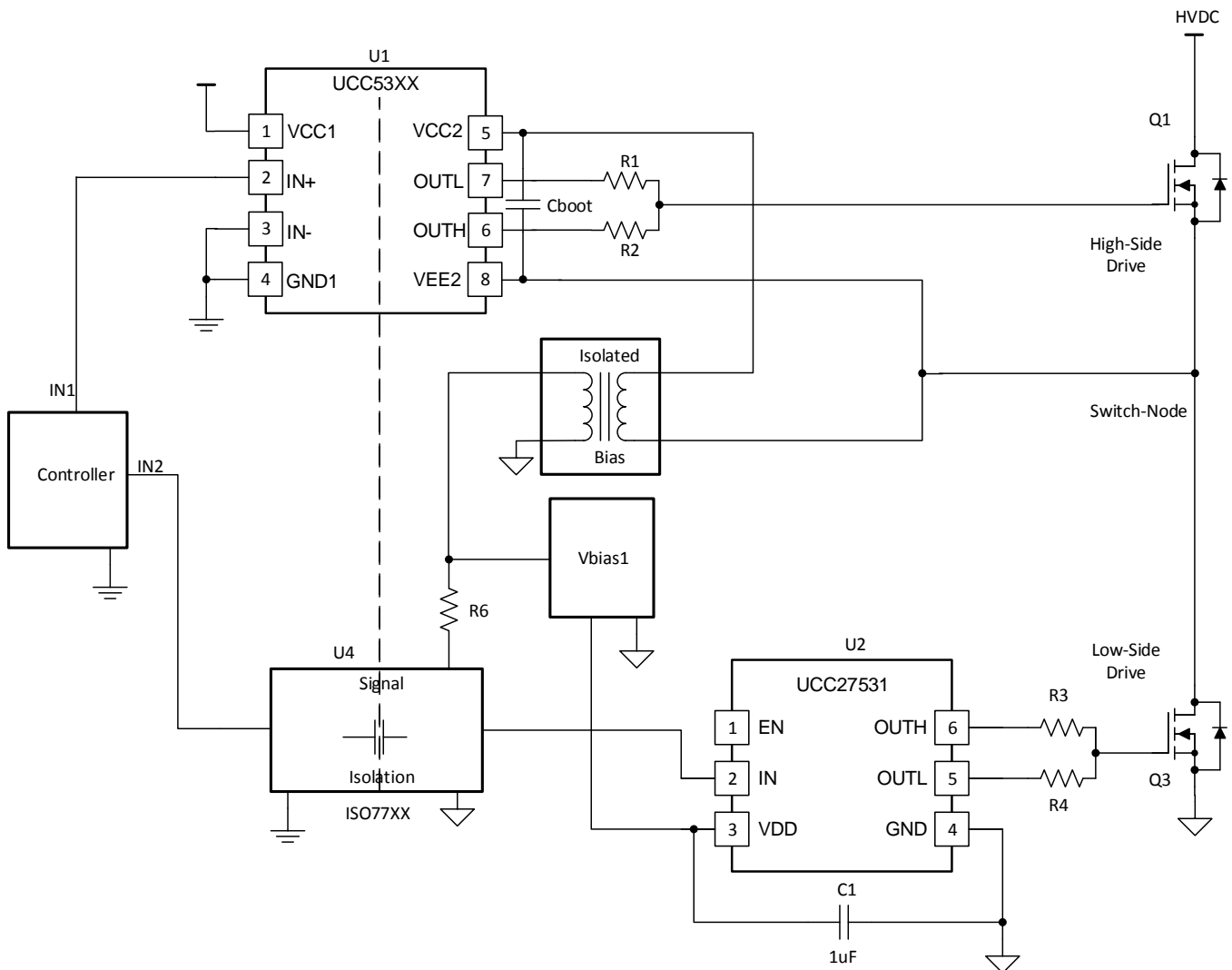

Figure 4. High-Side Isolated Driver and Bias Supply

Signal Isolation

In Figure 4, the input signals are isolated using an isolated gate driver for the high side and ISO77xx for the low side.

High-Side Bias

In Figure 4, U1, Isolated gate driver, UCC53xx is used as a high-side driver, and is supplied using an isolated bias supply on the power side and VCC from the signal side. The supply Vbias1 is referenced to the GND pin or power ground of a non-isolated UCC27531 and also supplies the floating bias for the high-side. This is similar to the configuration in the UCC27531EVM-184 or UCC5390SCDEVM-010, where non-regulated, isolated supplies such as SN650x are used.

2.4 Bootstrap Bias Supply with Isolated High/Low side Gate-Driver Solution

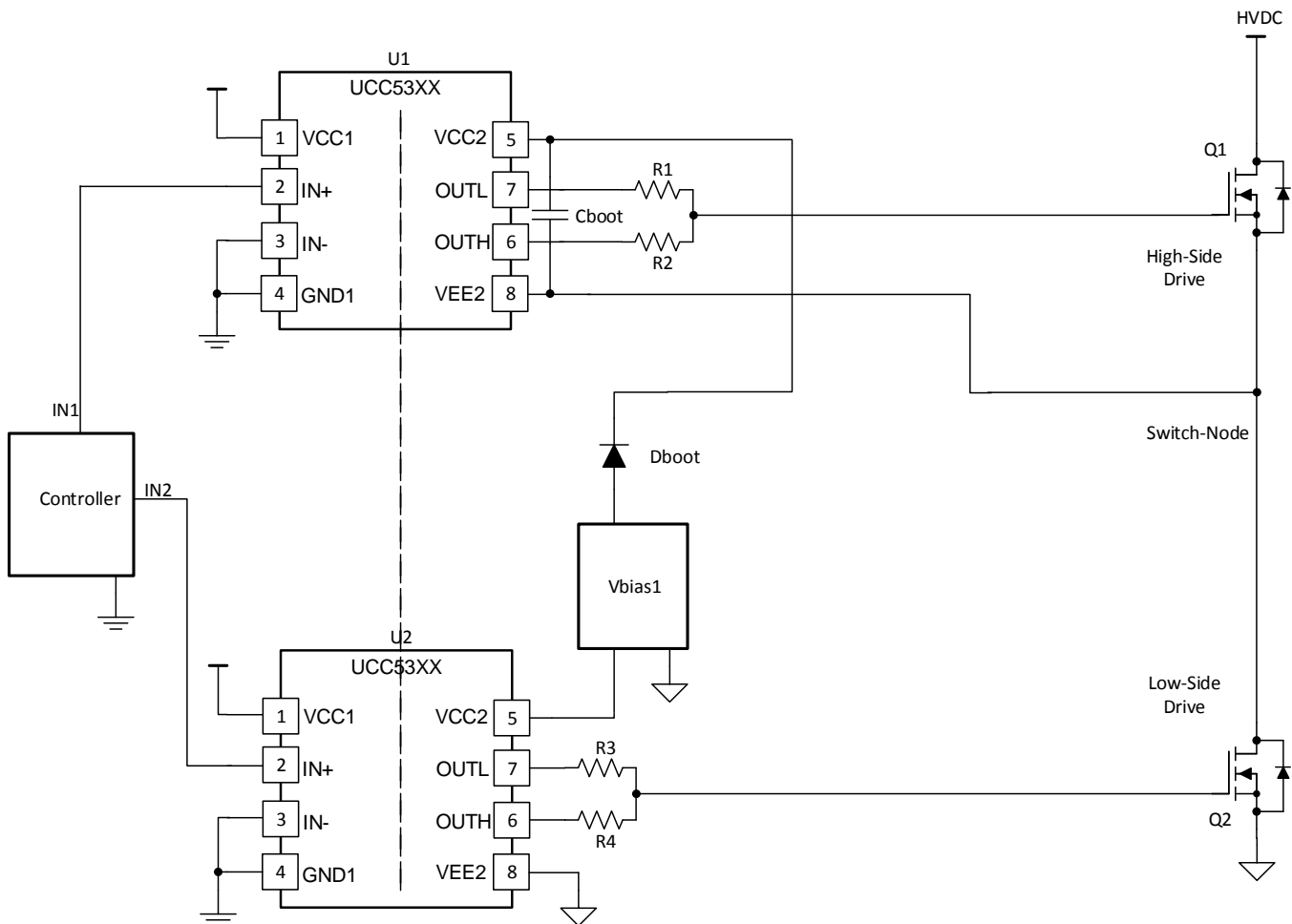

Figure 5. Isolated Drivers Using High-Side Bootstrap Circuit

Signal Isolation

The input signals of U1 are isolated in [Figure 5](#), with the isolated gate driver, UCC53xx. This allows the signal to operate properly, even as the signal reference (switch-node) changes voltage throughout the switching period. It also isolates the controller ground from the switch-node and power ground.

High-Side Bias

In [Figure 5](#), Dboot and Cboot are used as a bootstrap circuit to bias U1 properly. In the UCC27712 datasheet, refer to for selecting Cboot and for selecting Dboot.

2.5 Gate-Drive Transformer Solution

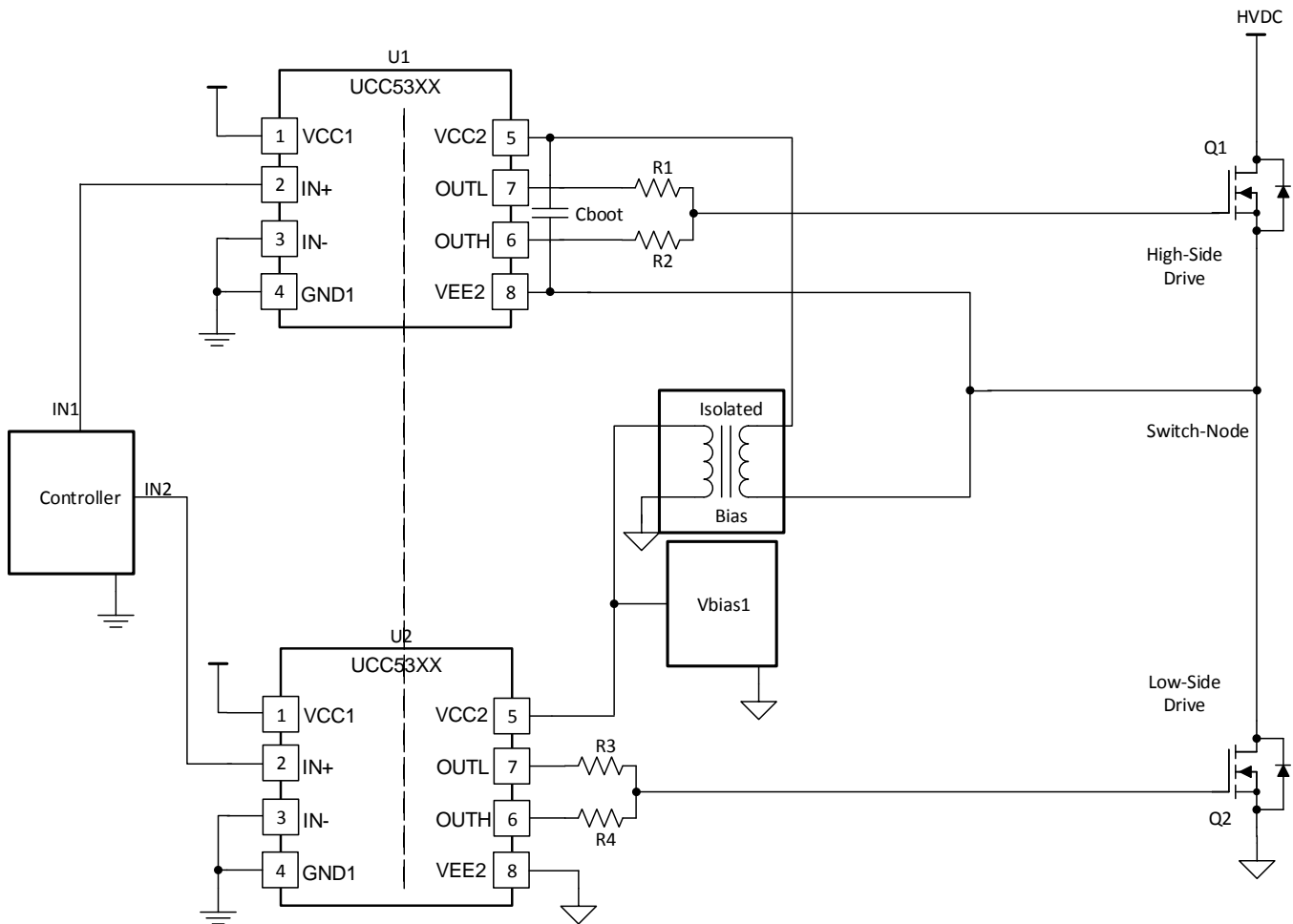

Figure 6. Isolated Drivers Using Isolated Bias Supply

Signal Isolation

The input signals of U1 are isolated in [Figure 5](#), with the isolated gate driver, UCC53xx. The isolated bias, a transformer, allows the gate signal to Q1 to have a floating reference that can move as the switch-node moves in voltage.

High-Side Bias

In [Figure 5](#), signal isolation is not needed because the gate drivers provide this internally. In this configuration, a bootstrap supply is not needed because of the isolated bias. Vbias1, referenced to power ground, supplies the floating bias for the high-side.

3 Conclusion

Driving the gates of LS power switches is fairly simple in terms of signal path and proper biasing. Driving floating-source switches such as HS MOSFETs in bridge configurations, however, presents some challenges in terms of both signal path and bias for the HS gate driver. This paper has presented numerous circuit examples that have shown different methods of achieving HS gate driving using a single-output gate driver.

Revision History

NOTE: Page numbers for previous revisions may differ from page numbers in the current version.

Changes from original Revision (March 2013) to A Revision	Page
• Changed Figure 2 to include PNP turn off method	3
• Added highside isolated gate driver to Figure 4.....	5
• Added highside and lowside isolated gate driver to Figure 5	6
• Added highside and lowside isolated gate driver with isolated bias to Figure 5	7

IMPORTANT NOTICE FOR TI DESIGN INFORMATION AND RESOURCES

Texas Instruments Incorporated ("TI") technical, application or other design advice, services or information, including, but not limited to, reference designs and materials relating to evaluation modules, (collectively, "TI Resources") are intended to assist designers who are developing applications that incorporate TI products; by downloading, accessing or using any particular TI Resource in any way, you (individually or, if you are acting on behalf of a company, your company) agree to use it solely for this purpose and subject to the terms of this Notice.

TI's provision of TI Resources does not expand or otherwise alter TI's applicable published warranties or warranty disclaimers for TI products, and no additional obligations or liabilities arise from TI providing such TI Resources. TI reserves the right to make corrections, enhancements, improvements and other changes to its TI Resources.

You understand and agree that you remain responsible for using your independent analysis, evaluation and judgment in designing your applications and that you have full and exclusive responsibility to assure the safety of your applications and compliance of your applications (and of all TI products used in or for your applications) with all applicable regulations, laws and other applicable requirements. You represent that, with respect to your applications, you have all the necessary expertise to create and implement safeguards that (1) anticipate dangerous consequences of failures, (2) monitor failures and their consequences, and (3) lessen the likelihood of failures that might cause harm and take appropriate actions. You agree that prior to using or distributing any applications that include TI products, you will thoroughly test such applications and the functionality of such TI products as used in such applications. TI has not conducted any testing other than that specifically described in the published documentation for a particular TI Resource.

You are authorized to use, copy and modify any individual TI Resource only in connection with the development of applications that include the TI product(s) identified in such TI Resource. NO OTHER LICENSE, EXPRESS OR IMPLIED, BY ESTOPPEL OR OTHERWISE TO ANY OTHER TI INTELLECTUAL PROPERTY RIGHT, AND NO LICENSE TO ANY TECHNOLOGY OR INTELLECTUAL PROPERTY RIGHT OF TI OR ANY THIRD PARTY IS GRANTED HEREIN, including but not limited to any patent right, copyright, mask work right, or other intellectual property right relating to any combination, machine, or process in which TI products or services are used. Information regarding or referencing third-party products or services does not constitute a license to use such products or services, or a warranty or endorsement thereof. Use of TI Resources may require a license from a third party under the patents or other intellectual property of the third party, or a license from TI under the patents or other intellectual property of TI.

TI RESOURCES ARE PROVIDED "AS IS" AND WITH ALL FAULTS. TI DISCLAIMS ALL OTHER WARRANTIES OR REPRESENTATIONS, EXPRESS OR IMPLIED, REGARDING TI RESOURCES OR USE THEREOF, INCLUDING BUT NOT LIMITED TO ACCURACY OR COMPLETENESS, TITLE, ANY EPIDEMIC FAILURE WARRANTY AND ANY IMPLIED WARRANTIES OF MERCHANTABILITY, FITNESS FOR A PARTICULAR PURPOSE, AND NON-INFRINGEMENT OF ANY THIRD PARTY INTELLECTUAL PROPERTY RIGHTS.

TI SHALL NOT BE LIABLE FOR AND SHALL NOT DEFEND OR INDEMNIFY YOU AGAINST ANY CLAIM, INCLUDING BUT NOT LIMITED TO ANY INFRINGEMENT CLAIM THAT RELATES TO OR IS BASED ON ANY COMBINATION OF PRODUCTS EVEN IF DESCRIBED IN TI RESOURCES OR OTHERWISE. IN NO EVENT SHALL TI BE LIABLE FOR ANY ACTUAL, DIRECT, SPECIAL, COLLATERAL, INDIRECT, PUNITIVE, INCIDENTAL, CONSEQUENTIAL OR EXEMPLARY DAMAGES IN CONNECTION WITH OR ARISING OUT OF TI RESOURCES OR USE THEREOF, AND REGARDLESS OF WHETHER TI HAS BEEN ADVISED OF THE POSSIBILITY OF SUCH DAMAGES.

You agree to fully indemnify TI and its representatives against any damages, costs, losses, and/or liabilities arising out of your non-compliance with the terms and provisions of this Notice.

This Notice applies to TI Resources. Additional terms apply to the use and purchase of certain types of materials, TI products and services. These include; without limitation, TI's standard terms for semiconductor products (<http://www.ti.com/sc/docs/stdterms.htm>), [evaluation modules](#), and [samples](http://www.ti.com/sc/docs/sampterm.htm) (<http://www.ti.com/sc/docs/sampterm.htm>).

Mailing Address: Texas Instruments, Post Office Box 655303, Dallas, Texas 75265
Copyright © 2018, Texas Instruments Incorporated