

How to design heating and cooling systems for HEV/EVs



Arun T. Vemuri

General Manager, Automotive Body
Electronics and Lighting
Texas Instruments

Kevin Stauder

Systems Engineer, Automotive Body
Electronics and Lighting
Texas Instruments

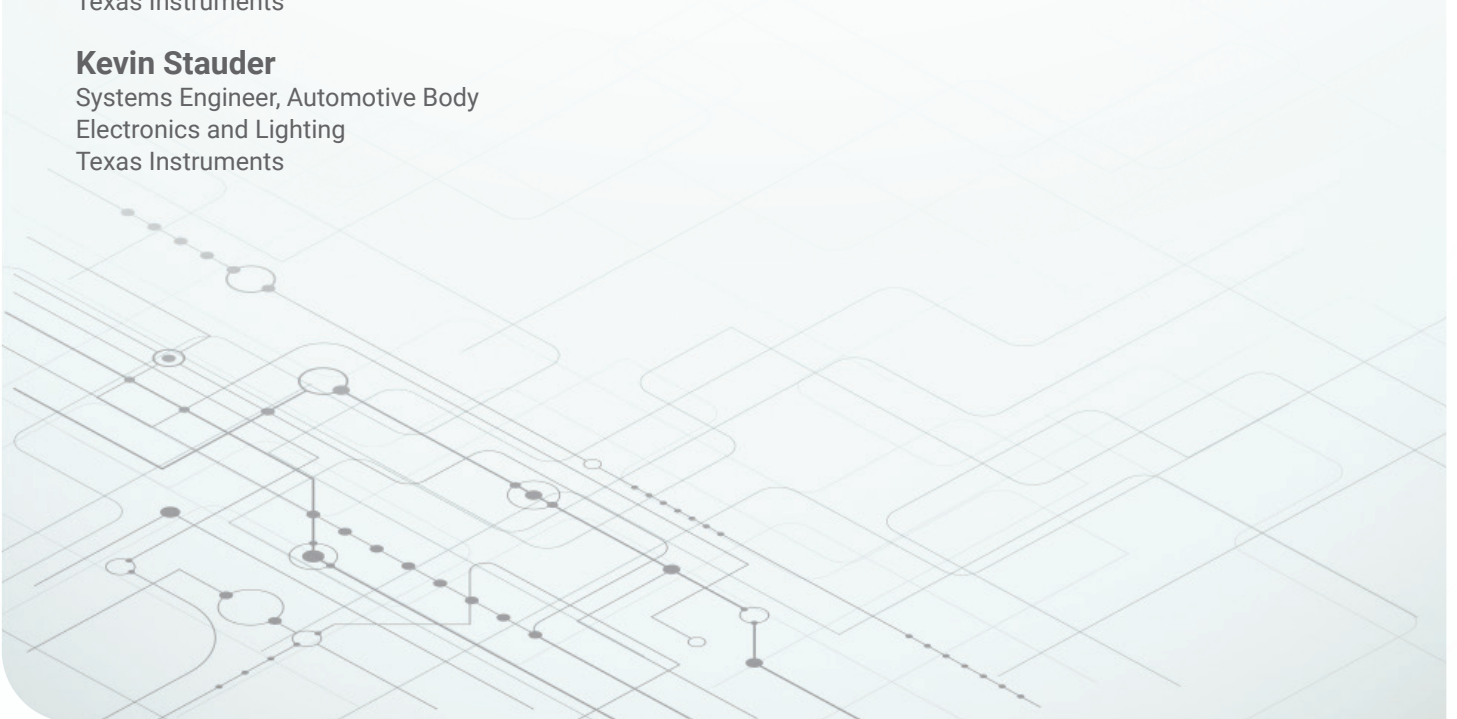

For decades, the internal combustion engine (ICE) has run the car as well as the heating and cooling systems. As the automotive industry electrifies and transitions to hybrid electric vehicles (HEVs) with small combustion engines or fully electric vehicles (EVs) with no engine at all, how will the heating, ventilation and air-conditioning (HVAC) systems work?

In this white paper, we will describe the new heating and cooling control modules in 48-V, 400-V or 800-V HEVs and EVs. From there, you will learn about the unique subsystems in these modules with examples and system diagrams, and we'll finish by reviewing functional solutions for these subsystems to help you start planning your implementation.

How a combustion engine works in an HVAC system

In a vehicle with an ICE, the engine is the foundation for the heating and cooling system. **Figure 1** illustrates this concept.

For **cooling**, the air from the blower fan enters the evaporator, where the refrigerant cools the air. The air conditioner (AC) compressor, which is driven by the engine, then compresses the refrigerant exiting the evaporator.

Similarly, for **heating** the air, heat generated by the engine is transferred to the coolant. This warm coolant enters the heater core, which heats the air that will blow into the cabin. That is how the engine plays a foundational role in the heating and cooling of a vehicle cabin.

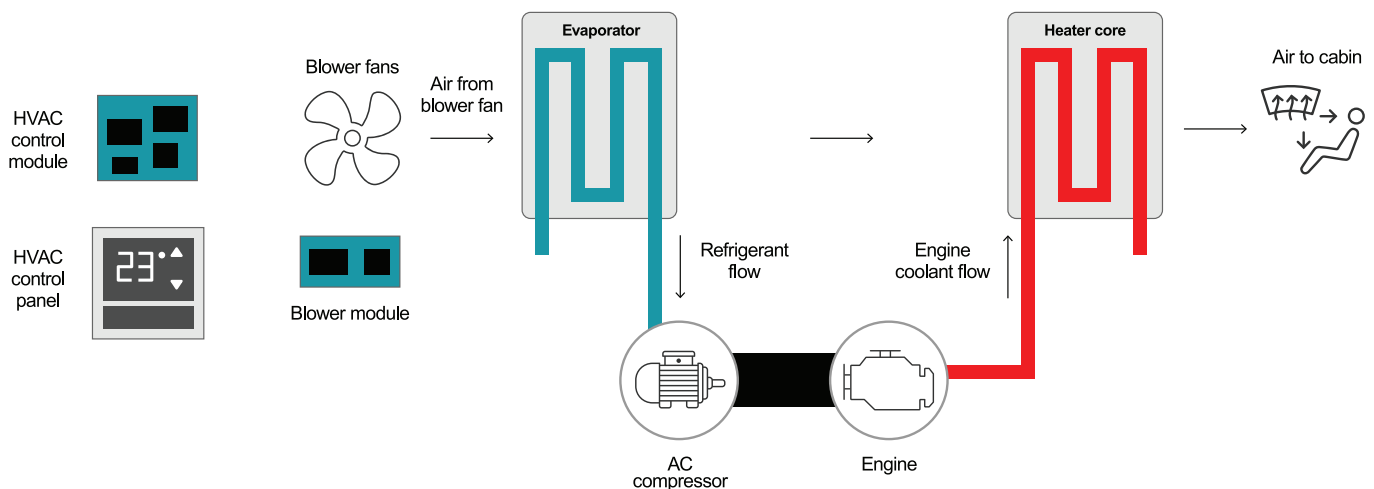

Figure 1. The engine plays a foundational role in an ICE vehicle's heating and cooling system.

How heating and cooling works in HEVs and EVs

In HEV/EVs, the sizing or the absence of a combustion engine requires the introduction of two additional components that play a key role in the HVAC system, as shown in **Figure 2**:

1. A brushless DC (BLDC) motor is a type of DC motor that rotates the AC compressor, instead of the engine.
2. A positive temperature coefficient (PTC) heater or alternatively, a heat pump, heats the coolant, rather than the engine.

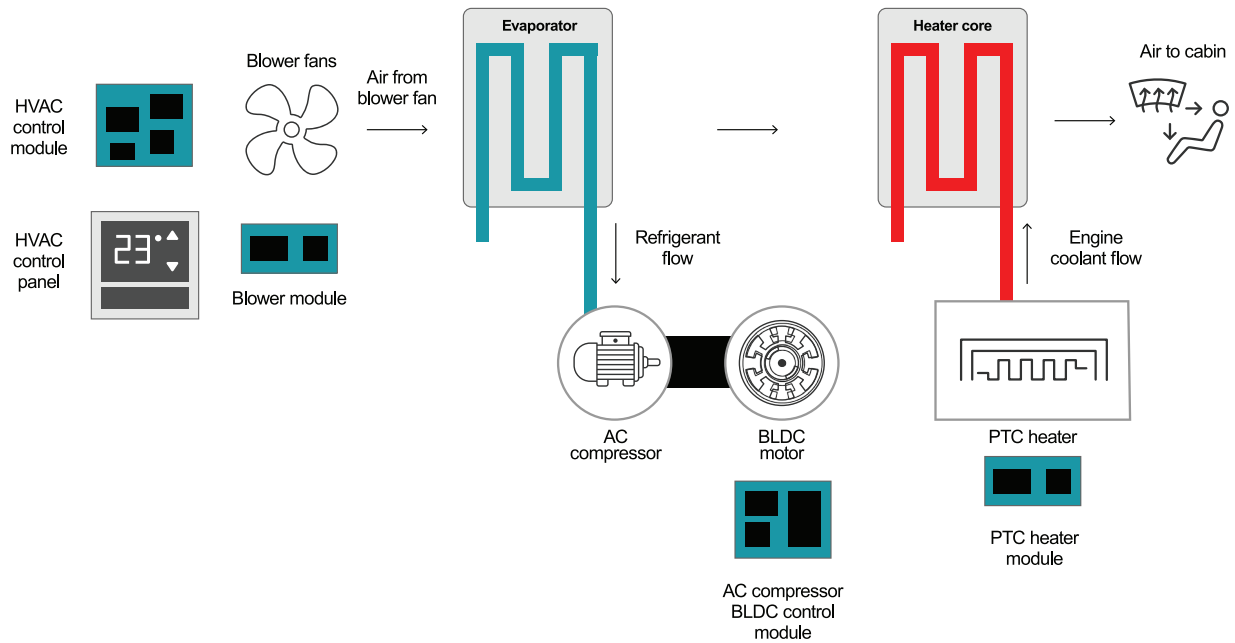

Figure 2. The heating and cooling system in a HEV/EV.

With the exception of these components, the rest of the heating and cooling system infrastructure is the same as it is in a vehicle with an ICE. As noted, the BLDC motor and PTC heater or heat pump are needed in the absence of an engine and bring separate challenges in power consumption, control of the motor and the resistive heater and overall HVAC control.

Electronics that control the BLDC motor and PTC heater

In high-voltage HEV/EVs, both the BLDC motor and PTC heater use high-voltage power. The AC compressor may need as much as 10 kW of power, while the PTC heater may consume as much as 5 kW of power.

Figures 3 and **4** are block diagrams of the AC compressor BLDC control module and the PTC heater control module, respectively. Both of these block diagrams show that the AC compressor BLDC motor and PTC heater are powered by a high-voltage battery. Furthermore, these modules both use insulated-gate bipolar transistors (IGBTs) and corresponding gate drivers to control power to the BLDC motor and PTC heater.

Figures 3 and **4** also illustrate the similarities between the rest of the subsystems for both control modules. Both systems include a power-supply subsystem, a gate-driver bias power supply, microcontrollers (MCUs), communication interfaces and temperature and current monitoring.

Many of the subsystems used in these control modules such as transceivers for communication and amplifiers for current measurement are similar to subsystems used in other heating and cooling control modules. However, the power-supply subsystem and the gate-driver subsystem are unique to these control modules in the heating and cooling system of the vehicle. These subsystems interface with the low-voltage domain as well as the high-voltage domain.

Later in this paper, we will discuss functional block diagrams of the circuit topologies used for these subsystems. Note that the choice of circuit topologies must achieve subsystem functionality as well as system-design requirements such as efficiency, power density and electromagnetic interference (EMI).

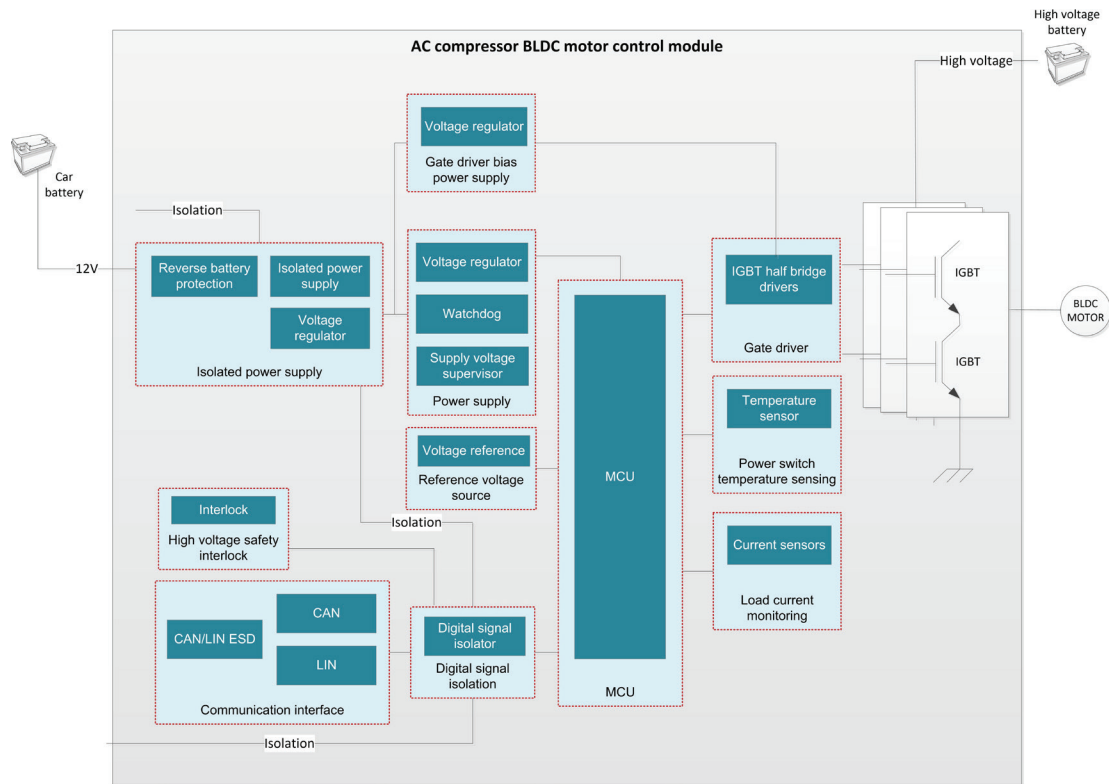

Figure 3. Block diagram of a high-voltage AC compressor BLDC motor control module.

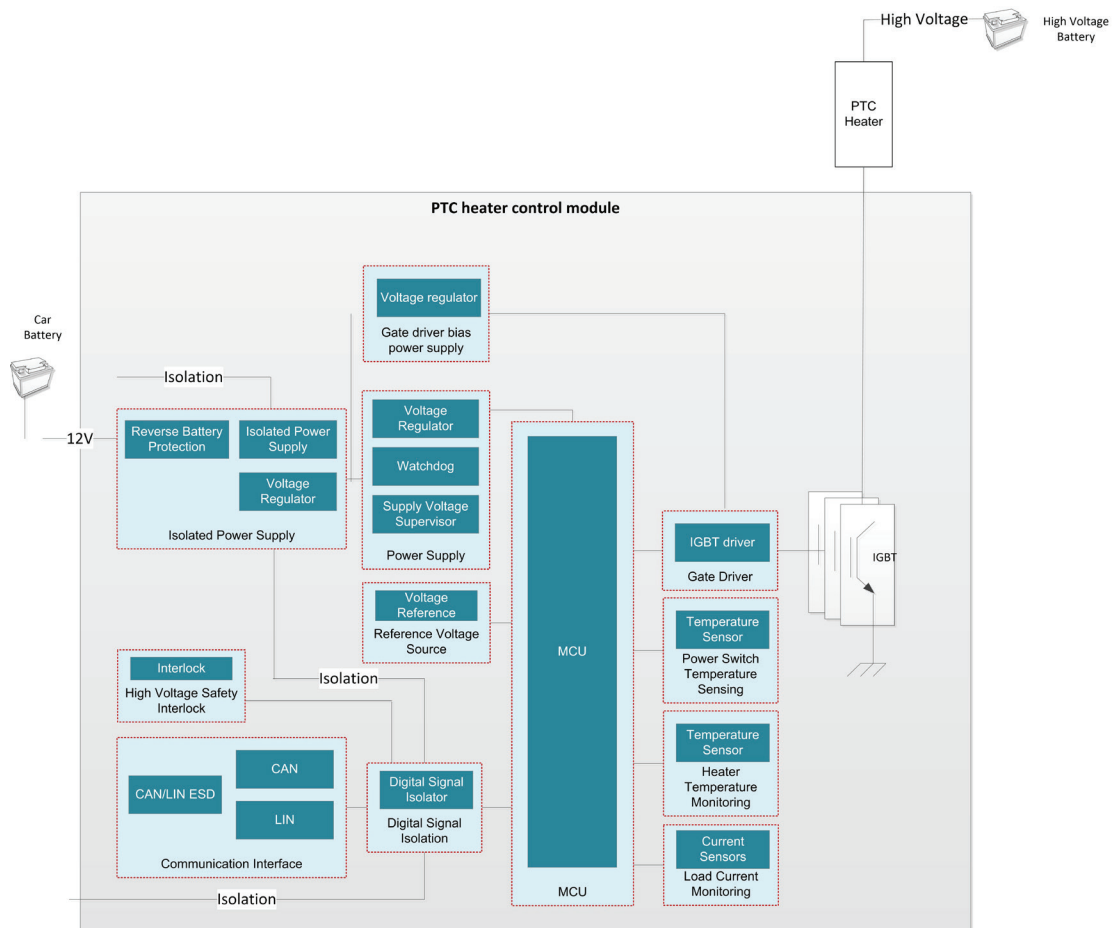

Figure 4. Block diagram of a high-voltage PTC heater control module.

Heat pumps

An alternative to using a high-power PTC heater to heat the cabin is to use a cooling circuit as a heat pump, illustrated

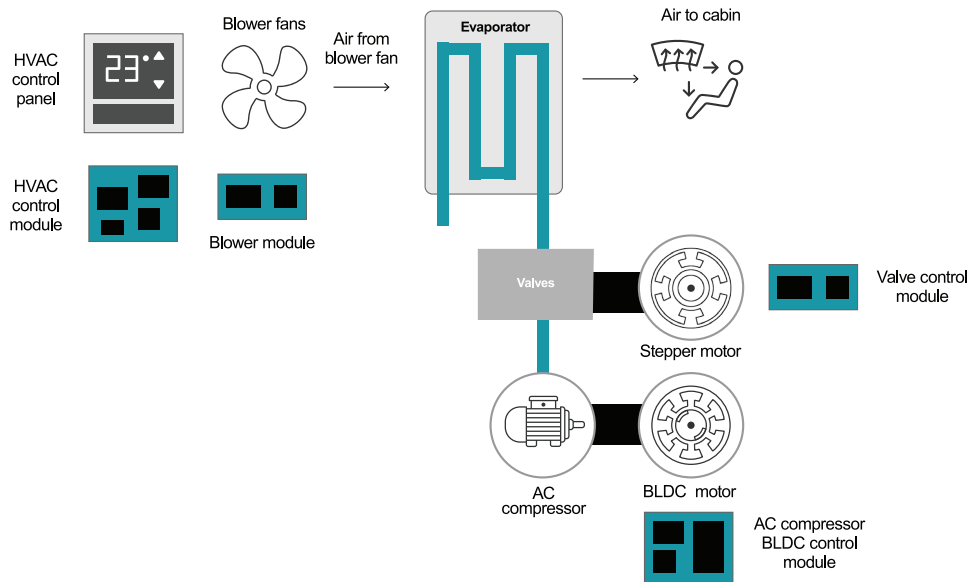

Figure 5. The heat pump system.

In heat-pump based heating and cooling system, the following types of valves are used:

- **Expansion valves** control the refrigerant flow. They help facilitate the change from the high-pressure liquid refrigerant in the condensing unit to the low-pressure gas refrigerant in the evaporator. Electronic expansion valves usually benefit from faster and more accurate responses to load changes and have more precise control of the refrigerant flow, especially when using a stepper motor to control the expansion valve.
- **Shutoff and reversing valves** change the direction or path of the refrigerant, enabling reverse cycles and bypass of some element for both heating and cooling modes. Either solenoid drivers or brushed DC motors can control shutoff and reversing valves.

From **Figure 5**, it can be inferred that the heat pump system still uses an AC compressor module, which was discussed in the previous section. In addition, heat-pump systems also use motor driver modules to drive the valves. This adds the additional design challenge of driving the valves for refrigerant flow.

Figure 6 shows a typical block diagram of a motor-driver module used to drive the valves. This diagram shows a stepper motor driver. If the motor was a brushed DC motor, a brushed DC motor driver would take the place of the stepper motor driver in this block diagram. The design requirements for motor driver modules include power density and EMI.

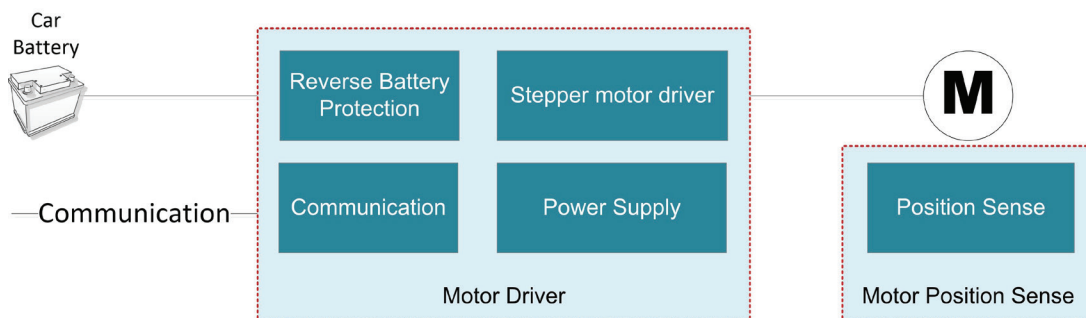

Figure 6. Block diagram of a stepper motor driver.

HVAC control module

Figure 7 is a typical block diagram for an HVAC control module. The HVAC control module controls the high-voltage contactors that are used to connect and disconnect the high-voltage battery to the BLDC motor and PTC heater. The block diagram also shows the damper motor control, defrost heater, communication interface and power-supply subsystems.

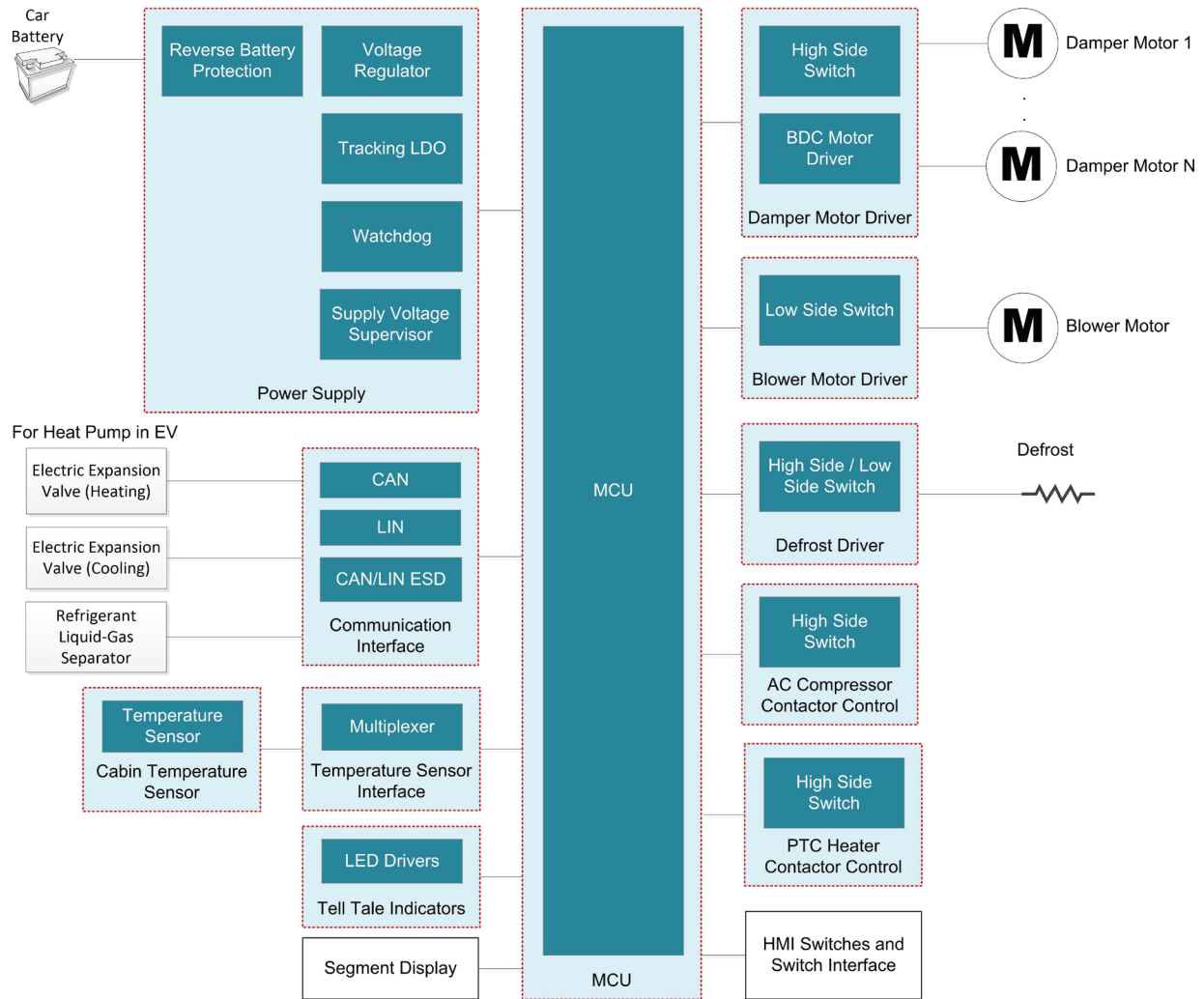

Figure 7. An HVAC control module.

A note about high-voltage battery heating and cooling:

Depending on the ambient temperature, it may be necessary to heat or cool the high-voltage battery. It is possible to accomplish this using the same systems that heat and cool the cabin. Alternatively, a separate heater could heat the coolant flowing into the battery. This coolant – while being used to heat the battery in cold temperatures – can also extract heat from the battery and direct that heat toward an exchanger to heat the cabin air. In such systems, stepper motors would control additional valves that would route the coolant fluid through plumbing in the battery and heat exchanger.

Typical functional block diagrams for the unique HVAC subsystems

As discussed previously, the additional control modules in the new heating and cooling systems in HEV/EVs include subsystems that are unique to these control modules – power supply, gate drivers and stepper motor valve drivers used to control refrigerant flow.

In this section, we explore typical functional block diagrams for circuit topologies of these subsystems in high-voltage AC compressor and PTC heater control modules. These topologies must deal with unique challenges including isolation barriers and EMI in HEV/EVs as we will discuss in the next sections.

Power supply

There are power-hungry heating and cooling subsystems for HEV/EVs, like the BLDC motor or PTC heater. But the rest of the subsystems in the module are typically low power, such as the MCU, gate drivers, temperature sensors and remaining circuits.

The typical approach would be to power the power-hungry load directly from the higher voltage available (800 V, 400 V or 48 V) and to power the circuits on the board from the 12-V rail, as shown in **Figure 8**.

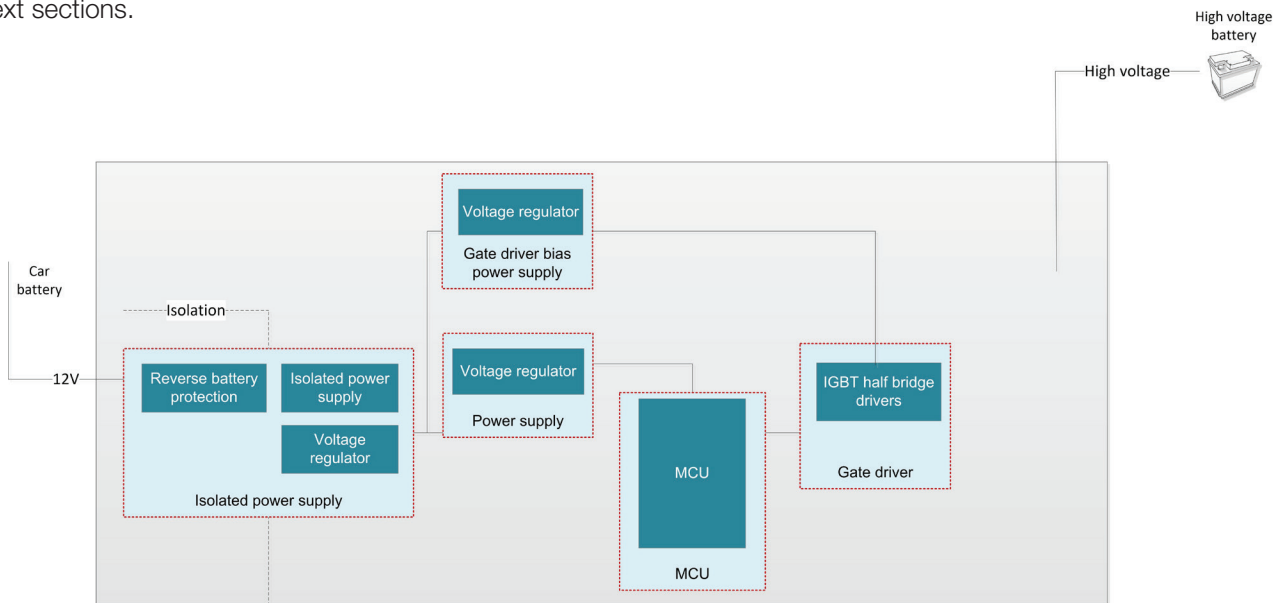

Figure 8. Powering the circuits in the control module from the 12-V rail.

In the 48-V system, while critical systems such as the starter/generator or traction inverter usually require an O-ring between supplies from the 12-V and 48-V rails. Heating and cooling subsystems often do not need this O-ring.

Figure 8 also shows an isolation barrier. In systems with high voltage, such as 800 V and 400 V, isolation between the 12-V side and high-voltage side is always required. However, in a 48-V vehicle, the answer is less direct. Because of the low voltage, electrical isolation may not be required between 12-V and 48-V systems in the vehicle. In practice, functional isolation (isolation to allow the system to work properly without necessarily serving as protection against electrical shock) will most likely be used between the 12-V and the 48-V domain.

It is possible to place the isolation barrier either at the input or output of the system. **Figure 8** shows the isolation barrier at the input of the system, where most of the system components are placed on the high-voltage side. In this case, the 12-V power and communication interface require isolation components. In contrast, if you were to place the isolation barrier at the output of the system, most of the circuit components should be located on the low-voltage side. In this case, the module would use isolated gate drivers to drive the transistors as shown in **Figure 9**.

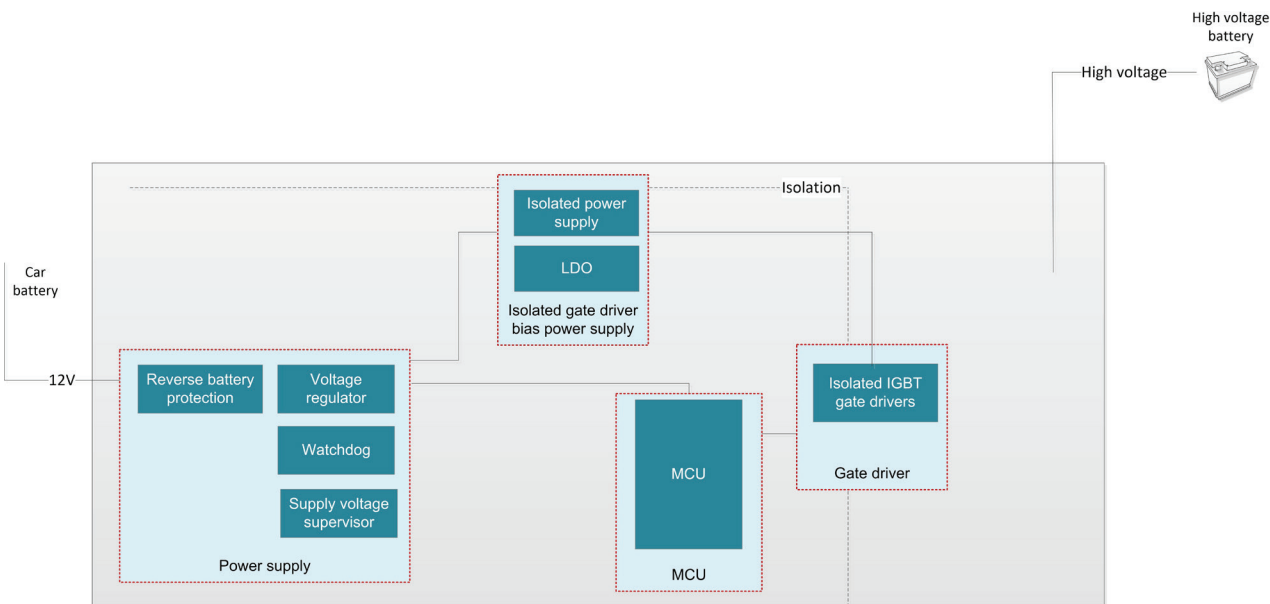

Figure 9. Powering the circuits in the control module from the 12-V rail.

The [Automotive High Voltage, High Power Motor Driver Reference Design For HVAC Compressor](#) shows an

example using the [LM5160-Q1](#) isolated fly buck-boost converter, which provides 16 V to the gate driver and 3.3 V (5.5 V followed by a low-dropout regulator) to the MCU, operational amplifiers and all other logic components. This approach is relatively simple, compact (using a single converter and transformer to generate both voltages) and offers good performance.

Gate drivers

You could use three-phase bridge driver integrated circuits (ICs) to drive the transistors of the inverter stage. Because of their low drive strength (<500 mA), however, three-phase bridge driver solutions typically require additional buffers to act as a current booster. This means additional components, which translates into additional costs; an increase in printed circuit board (PCB) size; and performance degradation with EMI risks and increased propagation delays of the overall system as a result of parasitics from the non-ideal PCB layout.

To help minimize switching losses from the transistors and reduce EMI for higher system efficiency, consider using half-bridge gate drivers such as the [UCC27712-Q1](#) to drive each phase of the inverter stage, as shown in **Figure 10**.

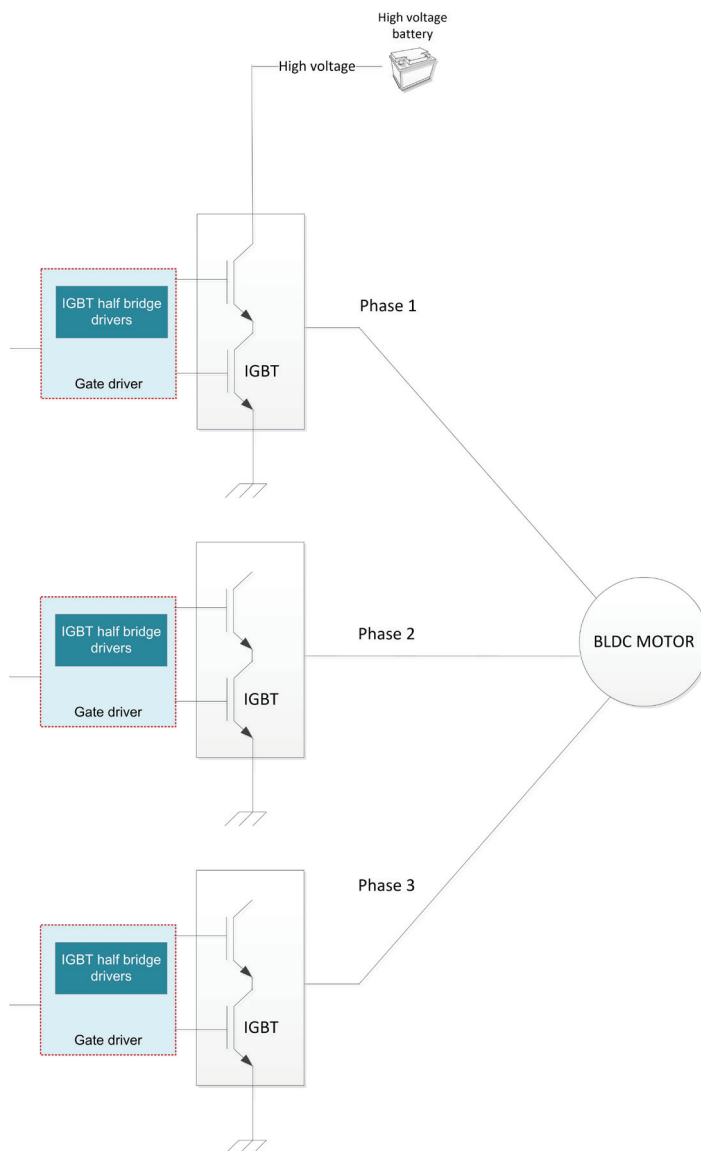

Figure 10. Driving the inverter stage with three half-bridge gate drivers.

From a gate-driver standpoint, EMI is often associated with overshoot at the gate. The half-bridge gate driver approach shown in **Figure 10** facilitates the removal of extra components and reduces the complexity of the PCB layout, because you can place the driver very close to the transistors while also confining the switch node to a minimal area. These efforts should result in fewer EMI challenges. In addition, the half-bridge gate drivers do not require an external booster stage to amplify the gate drive current, as the IC can achieve large-source and sink current. The half-bridge drivers typically implement interlock and dead-time functions to protect half bridges from shoot-through by preventing both outputs from turning on simultaneously and offers sufficient margin to effectively drive the transistors.

Stepper motor drivers

If stepper motor drivers are driving the valves in a heat pump system, an important feature to have in the stepper motor driver is stall detection; that is, the ability of the driver electronics to detect that the motor has stopped moving because it has hit a mechanical block, especially when the motor is being microstepped. Microstepping can achieve very precise position control of the valve.

Since the motor coils are driven by pulse-width modulated (PWM) signals, EMI does become an issue. The stepper motor driver must also have the ability to drive the load torque.

Devices such as the [DRV8889-Q1](#) integrate motor current sensing and advanced circuitry that help detect stalls during microstepping. The DRV8889-Q1 also includes programmable slew-rate control and spread-spectrum techniques to help mitigate EMI.

Summary

The introduction of new HVAC control modules due to the higher voltages in HEV/EVs creates new challenges such as power isolation, EMI and stall during microstepping. By leveraging typical circuit topologies with products such as isolated fly buck-boost converters, gate drivers and stepper motor drivers, you can smoothly navigate the move from ICE to HEV/EVs HVAC systems.

To get started on your HVAC design, see our [HVAC compressor module](#) or [HVAC control module](#) system overviews; to explore products and design resources for HEV/EVs see our [hybrid, electric and powertrain systems](#).

Important Notice: The products and services of Texas Instruments Incorporated and its subsidiaries described herein are sold subject to TI's standard terms and conditions of sale. Customers are advised to obtain the most current and complete information about TI products and services before placing orders. TI assumes no liability for applications assistance, customer's applications or product designs, software performance, or infringement of patents. The publication of information regarding any other company's products or services does not constitute TI's approval, warranty or endorsement thereof.

The platform bar is a trademark of Texas Instruments.
All other trademarks are the property of their respective owners.

IMPORTANT NOTICE AND DISCLAIMER

TI PROVIDES TECHNICAL AND RELIABILITY DATA (INCLUDING DATASHEETS), DESIGN RESOURCES (INCLUDING REFERENCE DESIGNS), APPLICATION OR OTHER DESIGN ADVICE, WEB TOOLS, SAFETY INFORMATION, AND OTHER RESOURCES "AS IS" AND WITH ALL FAULTS, AND DISCLAIMS ALL WARRANTIES, EXPRESS AND IMPLIED, INCLUDING WITHOUT LIMITATION ANY IMPLIED WARRANTIES OF MERCHANTABILITY, FITNESS FOR A PARTICULAR PURPOSE OR NON-INFRINGEMENT OF THIRD PARTY INTELLECTUAL PROPERTY RIGHTS.

These resources are intended for skilled developers designing with TI products. You are solely responsible for (1) selecting the appropriate TI products for your application, (2) designing, validating and testing your application, and (3) ensuring your application meets applicable standards, and any other safety, security, or other requirements. These resources are subject to change without notice. TI grants you permission to use these resources only for development of an application that uses the TI products described in the resource. Other reproduction and display of these resources is prohibited. No license is granted to any other TI intellectual property right or to any third party intellectual property right. TI disclaims responsibility for, and you will fully indemnify TI and its representatives against, any claims, damages, costs, losses, and liabilities arising out of your use of these resources.

TI's products are provided subject to TI's Terms of Sale (www.ti.com/legal/termsofsale.html) or other applicable terms available either on ti.com or provided in conjunction with such TI products. TI's provision of these resources does not expand or otherwise alter TI's applicable warranties or warranty disclaimers for TI products.

Mailing Address: Texas Instruments, Post Office Box 655303, Dallas, Texas 75265
Copyright © 2020, Texas Instruments Incorporated