

# Selecting Electrolytic Bus Capacitor for Universal input (85-V to 265-V RMS) Low Power Adapters ( $P_{in} < 75\text{-W}$ )

Isaac Cohen, Michael O'Loughlin

## 1 Introduction

In the past designers would have selected the converter's bus capacitor ( $C_{bus}$ ) using various approximations and "rules of thumb" which are not particularly accurate.

This application note presents a quick and reliable method for selecting the smallest electrolytic input bus capacitors that will provide the desired service life in ac-to-dc converters with capacitive input filters.

We will consider a quasi resonant flyback converter (Figure 1). Since most inexpensive simulator tools do not allow use of subscripts, so subscripts were intentionally left out of this application note.

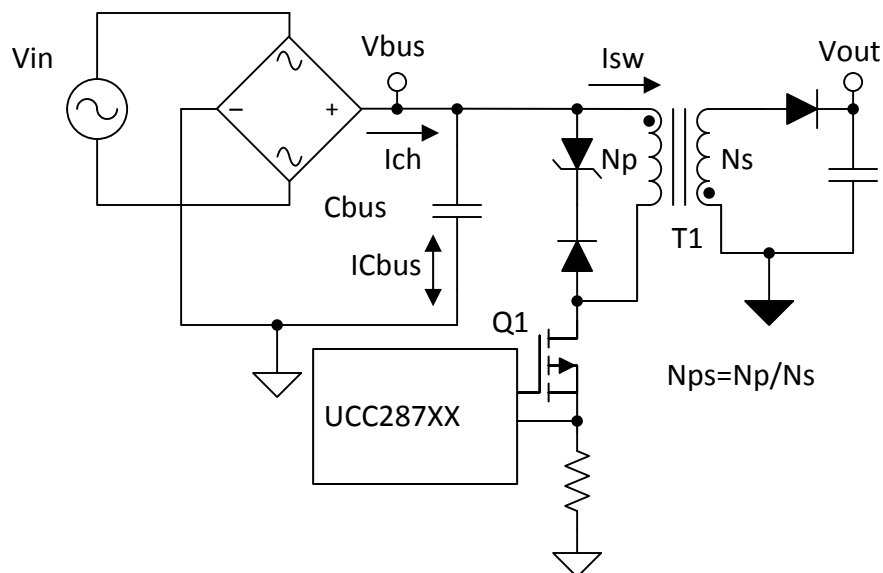

**Figure 1. Simplified Low Power AC-to-DC Adapter Flyback Schematic**

The bus capacitor  $C_{bus}$ , sometime referred to as the bulk capacitor, stores and delivers energy ( $w$ ) to the power system.

$$w = \frac{1}{2} C_{bus} \times V_{bus}^2 \quad (1)$$

Capacitor  $C_{bus}$  is charged every half line cycle by low frequency current and discharged continuously by the high-frequency current pulses drawn by the converter. This action results in a low frequency ac current ( $I_{lf}$ ) and a high frequency ac current ( $I_{hf}$ ) passing through  $C_{bus}$ . This application brief will use circuit simulation to obtain the RMS current of  $I_{lf}$  and calculate  $I_{hf}$  going through  $C_{bus}$ .

$$I_{Cbus} = I_{lf} + I_{hf} \quad (2)$$

The bus capacitor ( $C_{bus}$ ) selection algorithm consists of few simulation iterations of a circuit model based on the output power requirements ( $P_{out}$ ), assumed efficiency ( $\eta$ ), and the duty cycle of the converter ( $D$ ) this algorithm enables selection of capacitors that will provide the service life required by the application.

The algorithm will be illustrated for the converter with the following specifications:

- $P_{out} = 45\text{-W}$  output power
- $V_{out} = 20\text{-V}$ , output voltage
- $V_{in} = 85\text{-}265\text{-V}$  RMS, input voltage
- $\eta = 90\%$
- $V_{bus(\min)} = 75\text{ v}$ , lowest allowable dc bus voltage
- Service life: 2000 hours @full load, 100v 50hz input, 80°C internal ambient temperature.
- $f_{sw} = 100\text{ khz}$ , converter switching frequency @ highest  $I_{lf}$  and  $I_{hf}$
- $D_{\max} = 50\%$ , maximum duty cycle

Selecting the bus capacitor ( $C_{bus}$ ):

1. Select a bus capacitor voltage rating greater than the maximum bus voltage ( $V_{bus(\max)}$ ).

$V_{bus(\max)}$  can be calculated on the maximum RMS input voltage ( $V_{in(\max)}$ ) using equation 3. For this design the maximum bus voltage would be 375-V the voltage rating of  $C_{bus}$  needs to be rated for higher voltage than calculated, so 400-V is appropriate for this design.

$$V_{bus(\max)} = V_{in(\max)} \times \sqrt{2} = 265V \times \sqrt{2} = 375V \quad (3)$$

2. Assuming a minimum dc bus voltage of 75-V, calculate the average input current of the converter and select an initial bus capacitor ( $C_{bus(\text{init})}$ ) value based on 120uF/ampere dc:

$$C_{bus(\text{init})} = \frac{120\mu F}{1A} \times \frac{P_{out}}{V_{bus(\min)} \times \eta} = \frac{120\mu F}{1A} \times \frac{45W}{75V \times 0.9} \approx 80\mu F \quad (4)$$

3. We select the next standard value capacitor equal to or greater than  $C_{bus(\text{init})}$

$$C_{bus} = 82\mu F \quad (5)$$

4. Use your favorite circuit simulator and the model presented in figure 2 to extract the maximum  $C_{bus}$  low frequency current ( $I_{lf}$ ), which occurs at the maximum output power and minimum input voltage. In order to avoid division by zero at divider on  $C_{bus}$  should be set to a positive voltage (say 70-V) and the simulation run until the circuit reaches steady-state.

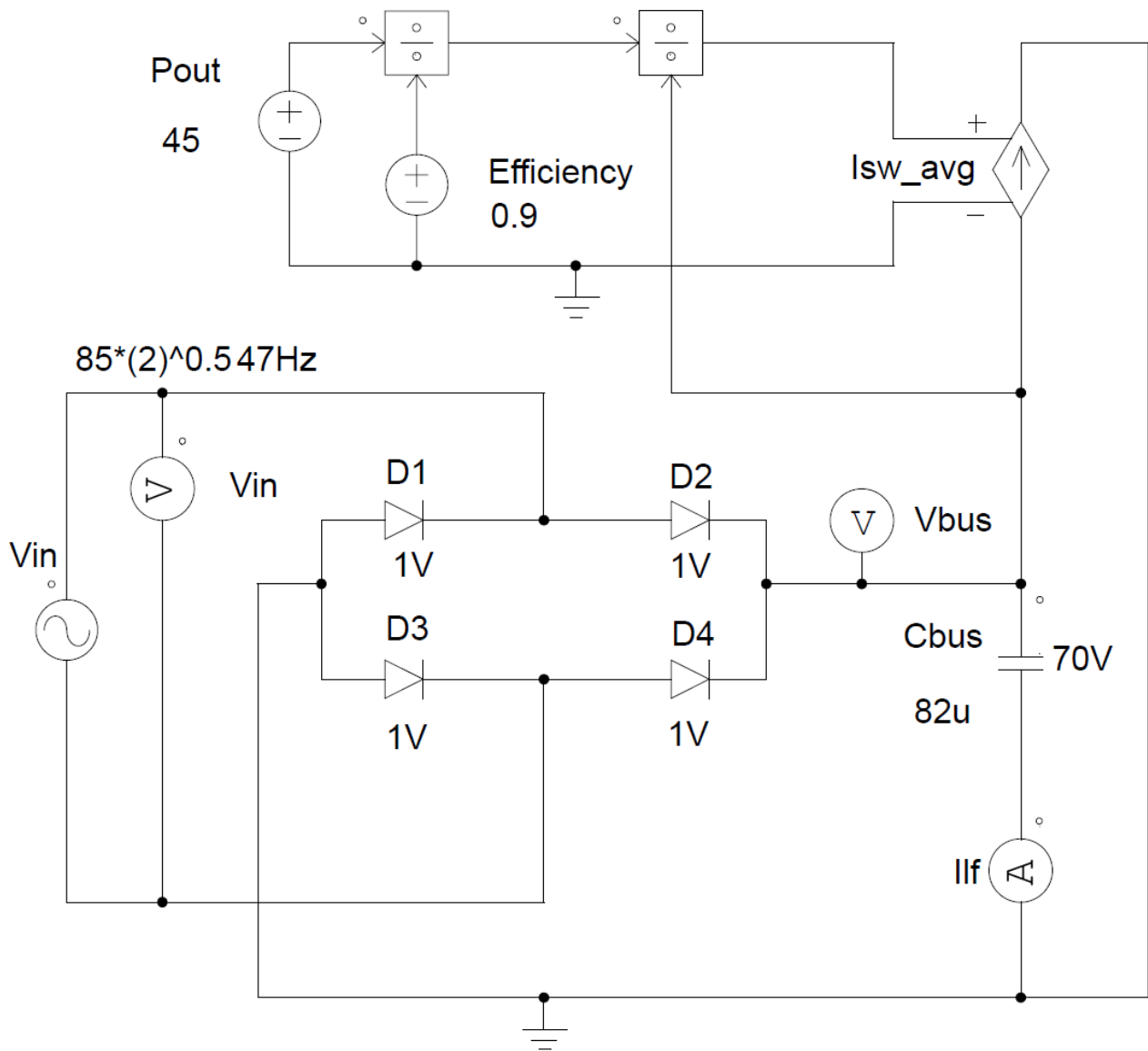

**Figure 2. Cbus Low Frequency Current (Ilf) Simulation Model**

The 82uf capacitor yields a minimum bus voltage of 71.6 v, which is below the minimum 75v bus voltage requirement, so a larger capacitance value must be selected.

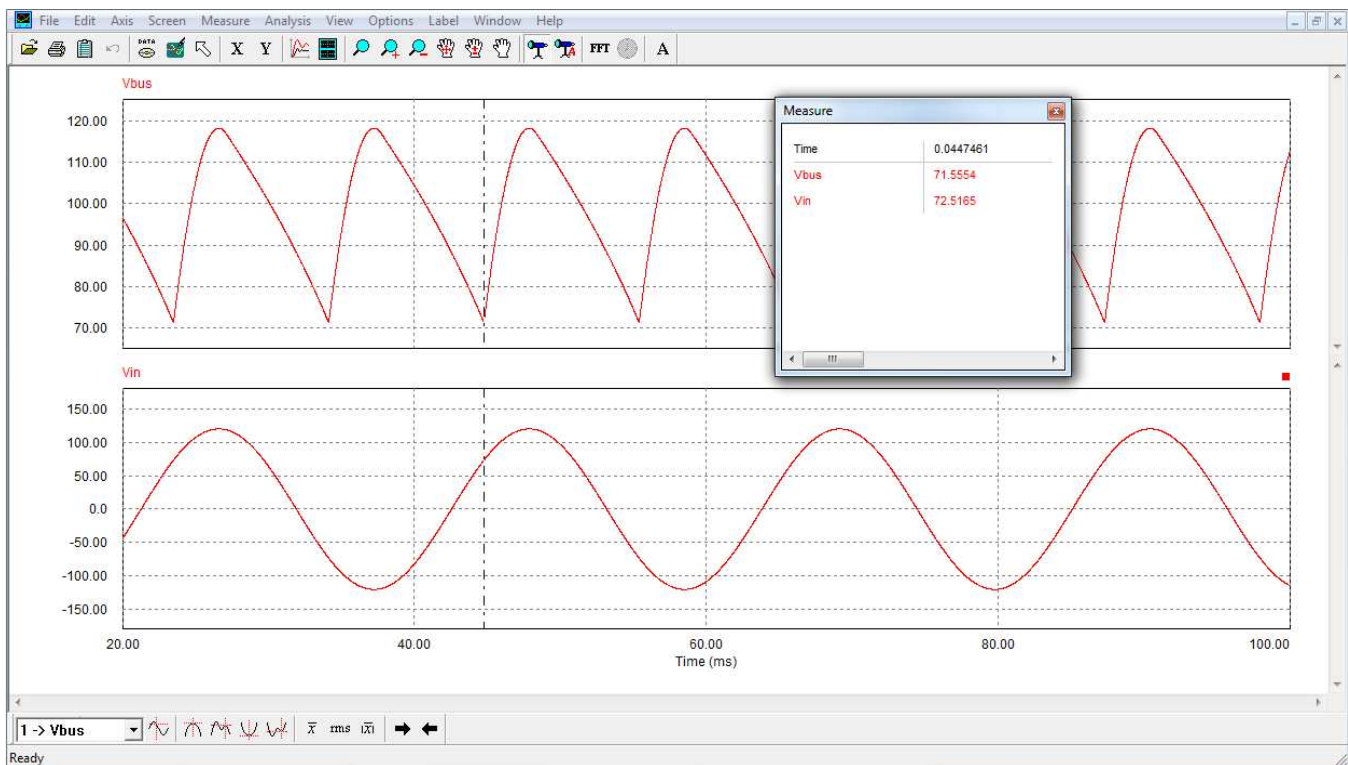
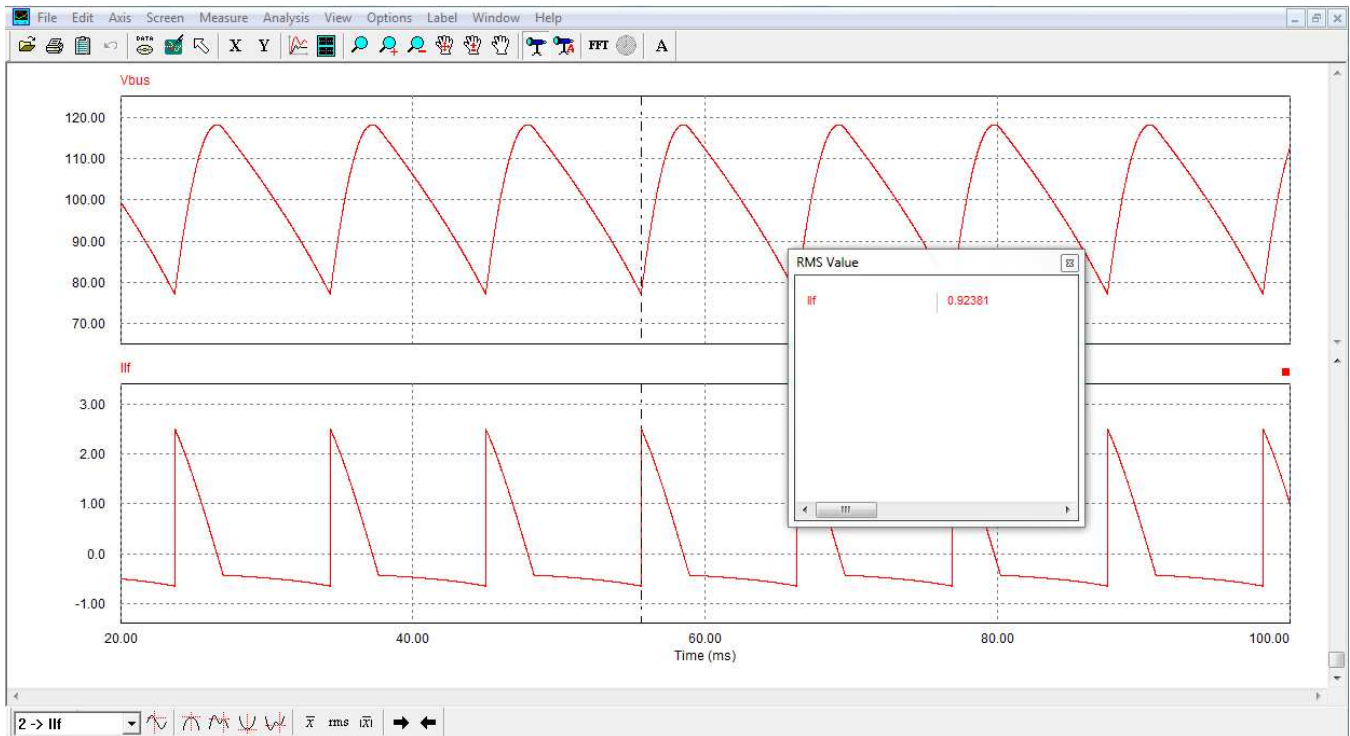

**Figure 3. first Vbus Ripple Voltage Simulation**

5. Selecting two 47uf capacitors in parallel for a total of 94 uf yields a minimum bus voltage of 78-V and a total (I<sub>lft</sub>) of 924 mA, 100-Hz RMS low frequency current , (462 mA of low frequency current (I<sub>lf</sub>) through each C<sub>bus</sub> capacitor).

$$I_{lft} \approx 924mA \tag{6}$$

$$I_{lf} \approx \frac{924}{2} mA = 462mA \tag{7}$$



**Figure 4. Ripple Voltage Simulation, Cbus = 2x47uf**

Having two capacitors in parallel provides the opportunity to create a differential mode EMI  $\pi$  filter by inserting an RF filter inductor ( $L_f$ ) in between the two caps (figure 5), which will force the high-frequency current to flow into  $C_{busb}$ , but have little impact on the sharing of low frequency current between the two capacitors.

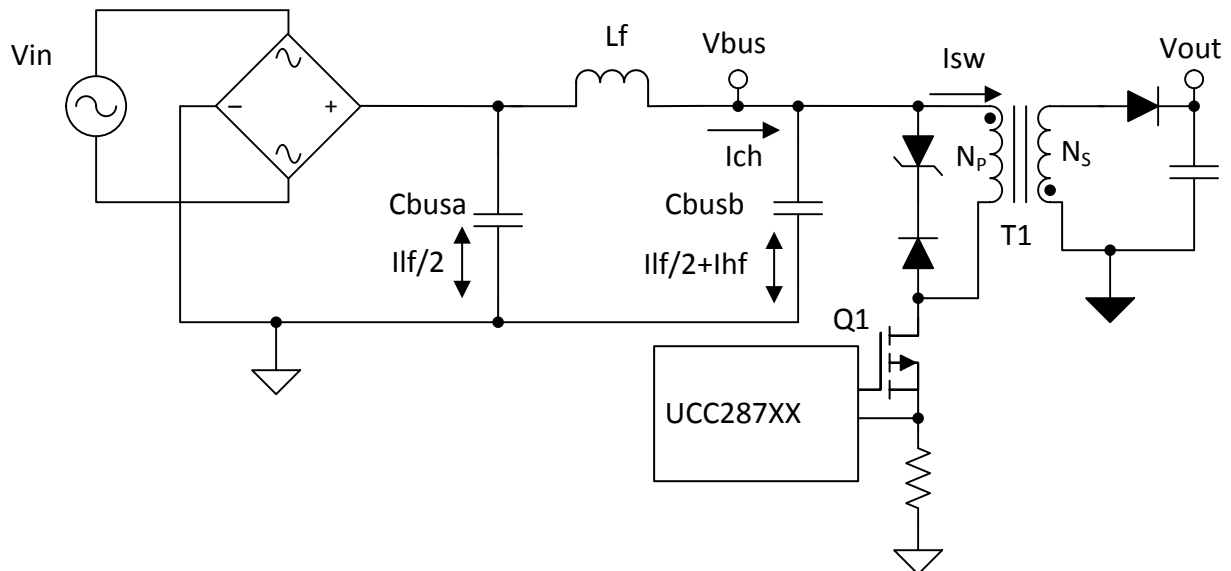

**Figure 5. low power offline power adaptor.**

The maximum high frequency RMS current ( $I_{hf}$ ) going through the bus capacitor ( $C_{busb}$ ) in this example can be calculated based on  $p_{out}$ ,  $V_{bus(min)}$ , estimated efficiency ( $\eta$ ), and knowing the converters maximum duty cycle. for this design example the maximum duty cycle was limited to 50%.

$$D_{max} = 0.5 \quad (8)$$

First calculate the peak switch current (I<sub>swpk</sub>):

$$I_{swpk} = \frac{P_{out} \times 2}{V_{bus(min)} \times Efficiency \times D_{max}} = \frac{45W \times 2}{78V \times 0.9 \times 0.5} \approx 2.56 \quad (9)$$

With I<sub>swpk</sub> the I<sub>hf</sub> RMS current can be calculated:

$$I_{hf} = \sqrt{\left( I_{swpk} \times \sqrt{\frac{D_{max}}{3}} \right)^2 - \left( I_{swpk} \times \frac{D_{max}}{2} \right)^2} \quad (10)$$

$$I_{hf} = \sqrt{\left( 2.56A \times \sqrt{\frac{0.5}{3}} \right)^2 - \left( 2.56 \times \frac{0.5}{2} \right)^2} = 826mA \quad (11)$$

- Once the simulation is complete and you have the simulated value of I<sub>lf</sub> and calculated I<sub>hf</sub> for the bus capacitor/s used in your design, extract from the datasheet of your favorite electrolytic capacitors family the rated 120 Hz ripple current (I<sub>lf</sub>), the frequency ripple current coefficient (K) and the rated load life (L) of 47-uf, 400-V at the current I<sub>lf</sub> and rated ambient temperature. For our example, we select an 47-uf capacitor with a 100-kHz ripple current rating (I<sub>lf</sub>) of 1.2-A @85° C, a frequency ripple current ripple coefficient K of 2 and load life L of 2000 hours @85°C.
- Calculate the effective RMS current (I<sub>eff</sub>) in the bus capacitor using equation 4 (see appendix for derivation):

$$I_{eff} = \sqrt{I_{lf}^2 + \frac{I_{hf}^2}{K^2}} = \sqrt{(462mA)^2 + \left(\frac{826mA}{2}\right)^2} \approx 620mA \quad (12)$$

- The load life L<sub>x</sub> of the capacitor can be calculated using equation 13. Please note there is a derivation of the formula in the appendix at the end of the application note. in our design example we are calculating L<sub>x</sub> based on:
  - T<sub>max</sub> is the rated ambient temperature from the datasheet (85° C for our case)
  - ΔT<sub>max</sub> is the maximum allowed hotspot temperature rise above the ambient T<sub>max</sub> (typically 5° C for 105° C rated capacitors, 15° C for 85° C rated capacitors - contact the manufacturer for more specific information)
  - L is the rated load life at @ the rated ambient temperature T<sub>max</sub> (2000 hrs. for our case)
  - T<sub>x</sub> is the operating ambient temperature (80°C for our case)
  - In our example the life of the capacitor is calculated to be 2144 hours
  - If this service life is not acceptable, the next larger value or higher ambient temperature (105oc instead of 85oc) can be selected – the change will have size and/or cost consequences.

$$L_x = L \times 2^{\left[ \frac{T_{max} - T_x + \Delta T_{max} \times \left(1 - \frac{I_{eff}^2}{I_{lf}^2}\right)}{10} \right]} = 2000hr \times 2^{\left[ \frac{85^\circ C - 80^\circ C + 5^\circ C \times \left(1 - \frac{(620mA)^2}{(462mA)^2}\right)}{10} \right]} = 2144hrs \quad (13)$$

This application note demonstrated with the use of proper simulation and modeling a bus capacitor or capacitors can be more accurately selected to meet your design requirements in low power offline flyback converters. This technique gives a more accurate prediction of the low and high frequency bus capacitor RMS current that can be used to select a better bus capacitor for the design with a longer life.

## 2 Appendix: Formulas Derivation.

### 1. Effective RMS current (I<sub>eff</sub>):

Since the capacitor's maximum internal temperature rise above the ambient is the same for low and high-frequency ripple current power dissipation must be equal for both:

$$ESR_{LF} \times I_{LF}^2 = ESR_{HF} \times I_{HF}^2 \quad (14)$$

$$\frac{I_{HF}}{I_{LF}} = K \quad (15)$$

(Where k is the frequency ripple current coefficient provided by the datasheet)

Therefore, the high frequency ESR is:

$$ESR_{HF} = \frac{I_{LF}}{K^2} \quad (16)$$

The equivalent RMS current for the mix of low and high-frequency currents will be:

$$I_{eff}^2 \times ESR_{LF} = I_{LFx}^2 \times ESR_{LF} + I_{HFx}^2 \times \frac{ESR_{LF}}{K^2} \quad (17)$$

$$I_{eff}^2 = \sqrt{\frac{I_{HFx}^2}{K^2} + I_{LFx}^2} \quad (18)$$

### 2. Life Expectancy Calculation:

The life expectancy vs. temperature of electrolytic capacitors follows arrhenius' law, i.e. it decreases by a factor of 2 for every 10°C increase in temperature. most caps manufacturers specify the internal hot spot ΔT of 5° c and 15° c respectively for capacitors rated 105° C and 85° C ambient temperature.

Defining:

- T<sub>max</sub> Rated ambient temperature
- ΔT<sub>max</sub> Maximum allowed internal hotspot temperature rise above Tmax
- T<sub>x</sub> Operating ambient temperature
- ΔT<sub>x</sub> Operating hotspot temperature rise above T<sub>x</sub>
- L Rated load life at T<sub>max</sub>
- L<sub>x</sub> Load life at T<sub>x</sub>

$$\Delta T_x = \Delta T_{max} \times \left(\frac{I_{eff}}{I_{LF}}\right)^2 \quad (19)$$

$$L_x = L \times 2 \frac{[T_{max} + \Delta T_{max} - (T_x + \Delta T_x)]}{10} \quad (20)$$

$$L_x = L \times 2 \frac{[T_{max} + \Delta T_{max} \times \left(1 - \frac{I_{eff}^2}{I_{LF}^2}\right)]}{10} \quad (21)$$



## IMPORTANT NOTICE AND DISCLAIMER

TI PROVIDES TECHNICAL AND RELIABILITY DATA (INCLUDING DATASHEETS), DESIGN RESOURCES (INCLUDING REFERENCE DESIGNS), APPLICATION OR OTHER DESIGN ADVICE, WEB TOOLS, SAFETY INFORMATION, AND OTHER RESOURCES "AS IS" AND WITH ALL FAULTS, AND DISCLAIMS ALL WARRANTIES, EXPRESS AND IMPLIED, INCLUDING WITHOUT LIMITATION ANY IMPLIED WARRANTIES OF MERCHANTABILITY, FITNESS FOR A PARTICULAR PURPOSE OR NON-INFRINGEMENT OF THIRD PARTY INTELLECTUAL PROPERTY RIGHTS.

These resources are intended for skilled developers designing with TI products. You are solely responsible for (1) selecting the appropriate TI products for your application, (2) designing, validating and testing your application, and (3) ensuring your application meets applicable standards, and any other safety, security, or other requirements. These resources are subject to change without notice. TI grants you permission to use these resources only for development of an application that uses the TI products described in the resource. Other reproduction and display of these resources is prohibited. No license is granted to any other TI intellectual property right or to any third party intellectual property right. TI disclaims responsibility for, and you will fully indemnify TI and its representatives against, any claims, damages, costs, losses, and liabilities arising out of your use of these resources.

TI's products are provided subject to TI's Terms of Sale ([www.ti.com/legal/termsofsale.html](http://www.ti.com/legal/termsofsale.html)) or other applicable terms available either on [ti.com](http://ti.com) or provided in conjunction with such TI products. TI's provision of these resources does not expand or otherwise alter TI's applicable warranties or warranty disclaimers for TI products.

Mailing Address: Texas Instruments, Post Office Box 655303, Dallas, Texas 75265  
Copyright © 2018, Texas Instruments Incorporated