

## ***UCD3138A Migration Guide***

---

*HPCS / HVPS*

### **ABSTRACT**

This application note describes the differences between Texas Instruments' UCD3138 and UCD3138A digital power controllers to assist in application migration. While the main focus of this document is migration from UCD3138 to UCD3138A, this document is also useful if you are considering migrating in the reverse direction. Functions that are identical in both devices are not necessarily included. All efforts have been made to provide a comprehensive list of the differences between the two device groups in the UCD3138 family.

---

### **Contents**

<b>1</b>	<b>Introduction</b>	<b>3</b>
<b>2</b>	<b>Device Overview summary</b>	<b>4</b>
	2.1 New Features	4
	2.1.1 Body diode conduction time sensing	4
	2.1.2 Duty Cycle Read During PCMC and CBC	5
	2.2 Bug Fix/ Enhancements	6
	2.3 Pin-multiplexing updates	7
	2.4 Revision update	8
<b>3</b>	<b>Migration Requirements for Specific TI EVMs/Topologies</b>	<b>8</b>
	3.1 Half Bridge LLC Topology	8
	3.2 Full Bridge LLC Topology	9
	3.3 HSFb Topology	9
	3.4 PSFB Topology	10
	3.5 PFC Topology	10
<b>4</b>	<b>Program Changes Required From UCD3138 to UCD3138A</b>	<b>11</b>
	4.1 Increase in DPWM Event Update Window	11
	4.2 Setting BLANK_PCM_EN bits for PCM	11
	4.3 Unused Bits and Modes Deleted on UCD3138A	11
<b>5</b>	<b>Bits Which No Longer Need to Be Written To</b>	<b>12</b>
<b>6</b>	<b>Enhancements Which Require Firmware Changes</b>	<b>12</b>
	6.1 Communication peripherals	12
	6.1.1 UART Hardware Support for Auto Baud and Increased Baud Rate Resolution	12
	6.1.2 PMBus supports 1 MHz bus speed.	13
	6.1.3 Improved Clock High Timeout Handling	13
	6.1.4 Improved Bit Counter Reset for Interrupted/Corrupted Messages	13
	6.2 Power Peripherals	13
	6.2.1 LLC Now Permits Fixed Frequency Sampling	13
	6.2.2 DPWM B Reactivation After Fault Without Shutting Down DPWM A	14

6.2.3	Any Front End Can be Used for PCM	14
6.2.4	Fault Counter Changes from 5 to 7 Bits	17
6.2.5	Blanking for the Cycle by Cycle Fault Added	17
6.2.6	Improved Fault and Burst Mode with Edge Generator in Use	17
6.3	ADC1218	
6.3.1	Sample and Hold Buffer Available on ADC even if Sample and Hold are Not Used	18
6.3.2	ADC Stop Sequence Capability	18
6.4	Oscillator	19
6.4.1	HFO trim bit field linearity	19
6.4.2	HFO Low Noise Filter Disabled Automatically	20
<b>7</b>	<b>Hardware/Board Changes</b>	<b>21</b>
7.1	Improved ADC Accuracy at lower temperature	21
7.2	Need for V33/BP18 Capacitor Eliminated	21
7.3	Migration from RHA package to RMH package.	21
	<b>References</b>	<b>21</b>
	<b>Appendix A. This is Appendix A's Title (Header:h0:Apx)</b>	<b>237</b>
A.1	This is an Appendix Heading Level A.1	237
A.1.1	This is an Appendix Heading Level A.1.1	237
	<b>Appendix B. This is Appendix B's title</b>	<b>237</b>
B.1	Resetting Table and Figure Captions at the Beginning of Each Appendix	237

### Figures

<b>Figure 1.</b>	<b>UCD3138 Block diagram</b>	<b>3</b>
<b>Figure 2.</b>	<b>UCD3138A Block diagram</b>	<b>3</b>
<b>Figure 3.</b>	<b>Low Side Gate Driver with Body Diode Conduction Sensing</b>	<b>5</b>
<b>Figure A-1.</b>	<b>Insert your figure caption here</b>	<b>237</b>

### Tables

<b>Table 1.</b>	<b>New Features in UCD3138A</b>	<b>4</b>
<b>Table 2.</b>	<b>Enhancements in UCD3138A</b>	<b>6</b>
<b>Table 3.</b>	<b>UCD3138ARGC Package</b>	<b>7</b>
<b>Table 4.</b>	<b>UCD3138ARMH Package</b>	<b>7</b>
<b>Table 5.</b>	<b>Chip Revision ID field updated</b>	<b>8</b>

# 1 Introduction

The UCD3138 and UCD3138A devices are members of the UCD3138 integrated digital power controller platform for use within isolated power control applications. In addition, to existing features from UCD3138 enhancements

Features:

- The General Purpose ADC has been improved for better accuracy and performance at extreme cold temperatures (-40C)
- The UART peripheral has been modified to include a hardware based auto-baud rate adjustment feature
- A new, Synchronous Rectifier Dead Time Optimization hardware peripheral has been added
- A Duty Cycle Read Function has been added to improve use in peak current mode
- PMBus/I2C peripherals can now operate up to 1MHz (Compliant with PMBus 1.3 Specification)

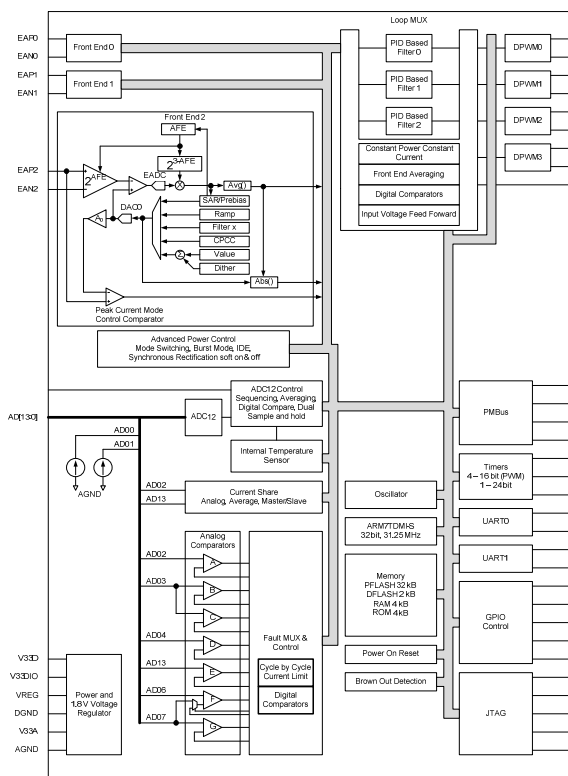

**Figure 1. UCD3138 Block diagram**

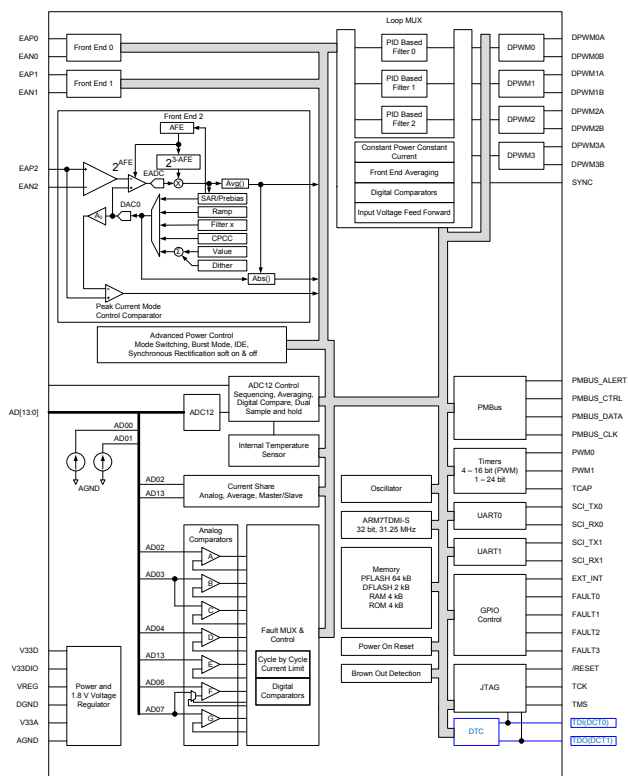

**Figure 2. UCD3138A Block diagram**

## 2 Device Overview summary

### 2.1 New Features

**Table 1. New Features in UCD3138A**

Peripheral	Features/ Changes	Detail Description
<b>DCT (new)</b>	Synchronous Rectifier Optimization Algorithm with body diode conduction time sensing	Addition of DTC pins for UCD7138 Synchronous Rectifier Driver with Body Diode Conduction Time Reporting
<b>Front End</b>	PCMC–Duty cycle read	Ability to read duty cycle during PCMC or CBC.

#### 2.1.1 *Body diode conduction time sensing*

Benefits:

- Maximize system efficiency by minimizing MOSFET body diode conduction time
- Robust fast negative current protection.
- Simple interface
  - Minimum component count
  - No external sense element
  - Easy layout
- Superior to  $R_{DSon}$  sensing techniques
  - Better accuracy across entire load range
  - No minimum on-time requirement
  - No parasitic L & R concerns

The UCD3138A has an advanced dead time control interface which accepts UCD7138 output signals and optimizes SR gate driver signals accordingly. The UCD7138 low-side MOSFET driver is a high performance driver for controlling secondary-side synchronous rectification (SR) using body diode conduction sensing. The combination of the two devices is suitable for high power high efficiency isolated converter applications where dead-time optimization is desired.

DCT0 and DCT1 are body diode conduction signals from the UCD7138. SR0\_DPWM and SR1\_DPWM are the DPWM waveforms from the UCD3138 to the UCD7138 to turn on the SRs. The yellow and green edges are moving edges controlled by both the filter output and the DTC interface. In each cycle, right after the falling edge of the SR DPWM waveform, a body diode conduction time detection window is generated. The detection window is defined by both DETECT\_BLANK and DETECT\_LEN registers. During this detection window, a 4-ns timer capture counts how long the body diode conducts. Then the SR DPWM turn off edge of the next cycle is adjusted accordingly.

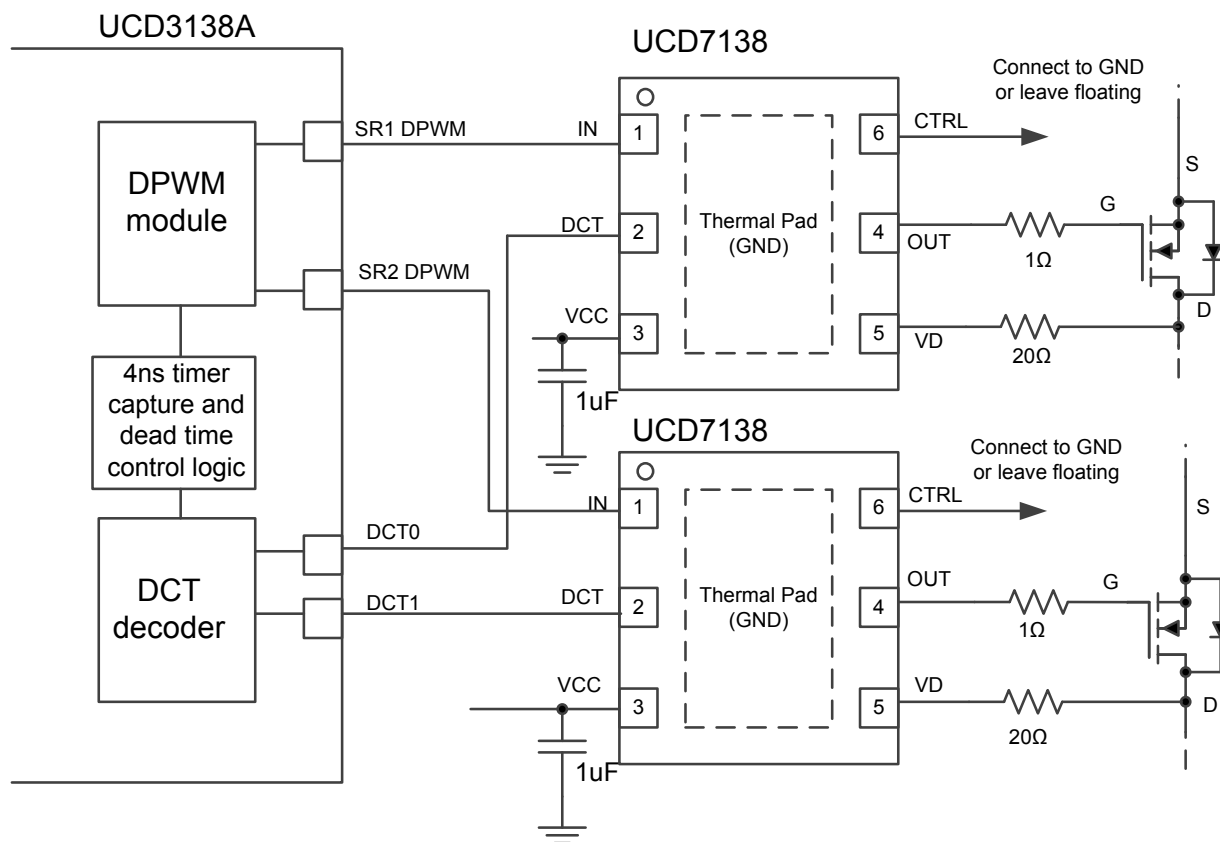

**Figure 3. Low Side Gate Driver with Body Diode Conduction Sensing**

### 2.1.2 Duty Cycle Read During PCMC and CBC

The UCD3138A adds a register which gives the DPWM counter value when a DPWM pulse is interrupted by a PCMC (Peak Current Mode Control) or CBC (Cycle by Cycle current limit) event. In PCM mode, this makes it possible to adjust the sample trigger time to read at the middle of the DPWM pulse time. This can give an average current level.

## 2.2 Bug Fix/ Enhancements

**Table 2. Enhancements in UCD3138A**

Peripheral	Features/ Changes	Detail Description
<b>ADC</b>	Improved ADC INL accuracy at -40C	UCD3138: INL +/-2.5 LSBs from 25°C to 125°C UCD3138A: INL +/- 4 LSBs across temperature
<b>DPWM</b>	DPWMxB can be turned back on without resetting the DPWM module.	UCD3138: If DPWMxB is latched off by fault, the whole DPWM module has to be re-enabled. UCD3138A: Adds a control so the DPWMxB can be restarted without turning off the entire module
<b>IO</b>	Power Up – I/O pin voltage outputs	UCD3138: A capacitor is required between V33 and BP18 UCD3138A: I/O voltage can drift up to 800 mV during the first 2 μs of device power up.
<b>DPWM</b>	Improved transient response and regulation over line and load variations for LLC converter.	UCD3138: Event update window 72ns. UCD3138A: Avoid moving edge to fall into EVTS update windows; Increased from 72ns to 132ns
<b>Front End</b>	PCMC -Configurable APCM Blanking in all FE's enables flexibility to use any FE for PCM.	UCD3138: Only Front End2 can be used for PCM as this supports configurable blanking. UCD3138A: Any Front end can be used for PCM as Configurable blanking is supported on all Front End.
<b>DPWM</b>	CBC–Blanking time for CBC fault and counter will not change due to voltage spikes	UCD3138: CBC counter is active during blanking time UCD3138A: CBC Counter will not increment due to voltage spikes
<b>PMBus</b>	High Clock Timeout Capability	UCD3138: The UCD3138 PMBus interface did not properly report the “Clock High Detected” event. UCD3138A: In UCD3138A , if the clock is high for more than 50 msec in the middle of a message, the PMBus interface will be reset and the CLOCK_HIGH_DETECTED bit will be set.
<b>PMBus</b>	PMBus–Interface status after Interrupted/Corrupted Messages	UCD3138: No proper response after interrupted messages or certain corrupted messages. UCD3138A: The PMBus interface will respond properly after interrupted messages or certain corrupted messages.
<b>ADC</b>	ADC Sample & Hold buffer Enable	UCD3138: has to enable dual sample and hold function to use the buffer. UCD3138A: Ability to buffer certain ADC inputs without enabling dual sample and hold function
<b>ADC</b>	ADC Stop sequence capability	UCD3138: unable to stop ADC conversion immediately. UCD3138A: Ability to stop ADC conversion immediately after ADC is disabled. A new ADC sequence can be started when re-enabling the ADC
<b>JTAG</b>	enhanced debug capability by Enabling JTAG from ROM	UCD3138: JTAG needs to be enabled. UCD3138A: JTAG is now enabled by default

<b>Oscillator</b>	HFO Low Noise Filter disabled	UCD3138: HFO filter is enabled by default. UCD3138A: Reduce HFO drift without enabling the filter Disabled by default in the ROM
<b>UART</b>	UART enhancements	UCD3138: no auto baud rate adjustment, baud rate clock resolution of 512 ns UCD3138A: UART auto calibration to correct baud rate, baud rate clock resolution of 64 ns
<b>PMBus</b>	1 MHz support	UCD3138: 400kHz support UCD3138A: 1 MHz support
<b>Front end</b>	PCMC Correct A0 offset	UCD3138: 100mV offset in PCMC front end. UCD3138A: A0 offset is changed from 100mV to 30mVmax; Less offset applied EAP;PCM response time is reduced;
<b>DAC</b>	Enhanced DAC Dither on each sample	UCD3138: dithers once per period UCD3138A: dithers once on each EADC sample
<b>Front end</b>	Auto Gear Shift AFE gain	UCD3138: only available on FE0 UCD3138A: Extended to all three Frond-ends
<b>DPWM</b>	DPWM Interrupt	UCD3138: DPWM period interrupt is generated continuously if DPWM is disabled. UCD3138A: it is disabled when DPWM disabled.
<b>DPWM</b>	LLC pulse extension during LLC-PWM mode switching	UCD3138: DPWM has pulse extension when mode switching from resonant to PWM and EADC sampling at the same time UCD3138A: LLC mode switching no longer has pulse extension
<b>DPWM</b>	DPWM–Fault Turn Off & Burst mode	UCD3138: When Edgegen module is used, fault may not be able to turn off all DPWMs. UCD3138A: In Edgegen applications, all faults will result in DPWMs going low

### 2.3 Pin-multiplexing updates

This device is 100% pin to pin backwards compatible to UCD3138. New DCT pins are available and multiplexed behind JTAG pins.

**Table 3. UCD3138ARGC Package**

Pin #	Name	Primary assignment	No 1	No 2	No 3	No 4
26	SYNC	SYNC	TCAP	ADC_EXT_TRIG	PWM0	DCT1
37	TCK	TCK	TCAP	SYNC	PWM0	DCT0
38	TDO	TDO	SCI_TX0	PMBUS_ALERT	FAULT0	DCT1
39	TDI	TDI	SCI_RX0	PMBUS_CTRL	FAULT1	DCT0

**Table 4. UCD3138ARMH Package**

Pin #	Name	Primary assignment	No 1	No 2	No 3	No 4
21	TCK	TCK	TCAP	SYNC	PWM0	DCT0
22	TDO	TDO	SCI_TX0	PMBUS_ALERT	FAULT0	DCT1

23	TDI	TDI	SCI_RX0	PMBUS_CTRL	FAULT1	DCT0
----	-----	-----	---------	------------	--------	------

## 2.4 Revision update

**Table 5. Chip Revision ID field updated**

Module	Features/ Changes	Detail Description
Chip Level	Device ID/Revision Update	Device ID is UCD3138A

## 3 Migration Requirements for Specific TI EVMs/Topologies

The UCD3138A is almost completely upward compatible with the UCD3138. Very few changes are typically required to migrate a code '38 code to the '38A. The changes are described in chapter 4. Here are the changes required for the TI EVM codes:

### 3.1 LLC Topology

- 1) Remove the following code:

```
MiscAnalogRegs.CLKTRIM.bit.HFO_LN_FILTER_EN = 0;
```

- 2) The event update window is increased to 132ns. Make sure that the moving edges are outside of the event update window.

UCD3138A has DTC interface that works in conjunction with UCD7138, helps improve reliability and efficiency and reduce development cycle. This peripheral is disabled by default. Please refer to Application note *Using UCD7138 and UCD3138A for Advanced Synchronous Rectification Control* [<http://www.ti.com/lit/pdf/slua737>] for more details on how to program DTC.

- 3) Dead time configuration changes  
The following figure illustrates some of the timing features of the UCD3138A LLC frequency modulation (i.e. resonant mode).



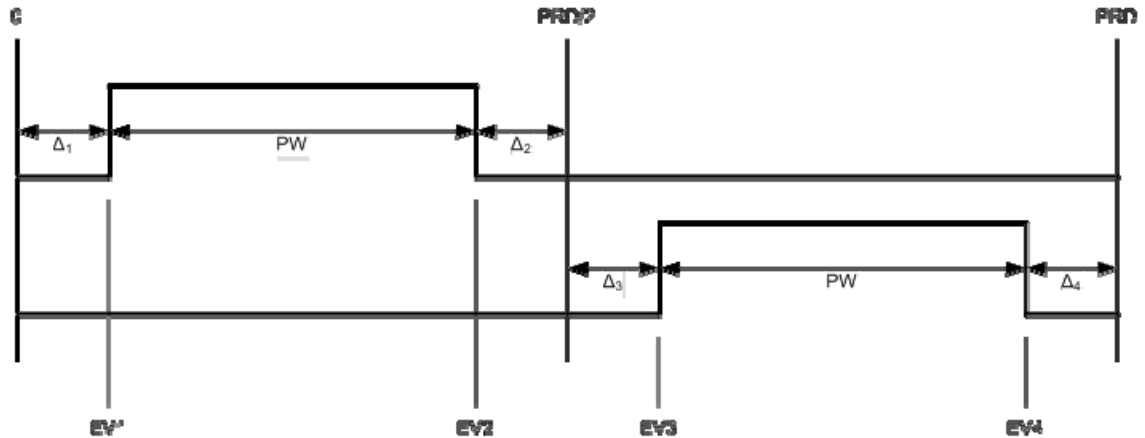

In the UCD3138 the following calculations hold true:

- $\Delta_1 = \text{EVENT\_1\_REG}$
- $\Delta_2 + \Delta_3 = \text{EVENT\_3\_REG} - \text{EVENT\_2\_REG}$
- $\Delta_4 = \text{PRD\_REG} - \text{EVENT\_4\_REG}$
- $\text{FILTER\_DUTY} = \text{PRD\_DUTY}/2$
- $\text{PW} = \text{FILTER\_DUTY} - (\Delta_1 + \Delta_2 + \Delta_3 + \Delta_4)/2$

In the UCD3138A we made the following changes to the calculation times. These changes only affect LLC.

- $\Delta_1 = \text{EVENT\_1\_REG}$
- $\Delta_2 + \Delta_3 = 2 * \text{EVENT\_1\_REG}$
- $\Delta_4 = \text{EVENT\_1\_REG}$
- $\text{FILTER\_DUTY} = \text{PRD\_DUTY}/2$
- $\text{PW} = \text{FILTER\_DUTY} - 2 * \text{EVENT\_1\_REG}$
- Events
  - $\text{EV1} = \text{EVENT\_1\_REG}$
  - $\text{EV2} = \text{EVENT\_1\_REG} + \text{PW}$
  - $\text{EV3} = \text{FILTER\_DUTY} + \text{EVENT\_1\_REG}$
  - $\text{EV4} = \text{FILTER\_DUTY} + \text{EVENT\_1\_REG} + \text{PW}$

### 3.2 PS- LLC Topology

Changes are the same as in Section 3.1 LLC Topology.

### 3.3 HSF B Topology

For voltage mode control, only events update window are necessary to be adjusted. At normal mode, change `DpwmxRegs.DPWMEV1.all = 480` or greater. At multiple mode, `EVT3` should be greater than 480ns.

For peak current mode control, the EVT update windows follow the same criteria as voltage mode control. Besides those changes, PCM blanking time should be programmed by `PCM_BLANK_EN` bit. For example, to select `DPWM0` blanking time and `DPWM1` blanking time, the below code should be used.

```
Dpwm0Regs.DPWMCTRL2.bit.BLANK_PCM_EN = 1;
```

```
Dpwm1Regs.DPWMCTRL2.bit.BLANK_PCM_EN = 1;
```

Delete the code `MiscAnalogRegs.CLKTRIM.bit.HFO_LN_FILTER_EN = 0` to improve high frequency clock accuracy.

UCD3138A has DCT interface that works in conjunction with UCD7138, helps improve reliability and efficiency and reduce development cycle. This peripheral is disabled by default. Please refer to Application note [xxx] for more details on how to program DCT.

### 3.4 PSFB Topology

The required changes of events update window in the PSFB topology are the same as the HSFb topology. In addition, few other changes are highlighted.

First, EDGEGEN modules are used in PSFB topology, at burst mode or fault condition, one of DPWMs aren't turned off in UCD3138 while all DPWMs are turned off in UCD3138A. This can affect power stage design. With UCD3138A, gate transformers can be used for driving primary side MOSFETs.

Second, the blanking time windows are programmed by the below codes for each half period.

```
Dpwm2Regs.DPWMCTRL2.bit.BLANK_PCM_EN = 1;
```

```
Dpwm3Regs.DPWMCTRL2.bit.BLANK_PCM_EN = 1;
```

Third, at Peak Current mode control, the offset applied on EAP pin (EAP2 for PWR027) is significantly reduced to less than 30mV. The offset voltage can be removed if a small voltage step is acceptable.

Fourth, delete the code `MiscAnalogRegs.CLKTRIM.bit.HFO_LN_FILTER_EN = 0`, which is not needed any more;

Some other enhancements are listed in the Table 2, such as DAC dithering, reading duty cycle when CBC happens or PCM control, and so on.

### 3.5 PFC Topology

Please note following modifications are required to support UCD3138A

- Delete this code:

```
MiscAnalogRegs.CLKTRIM.bit.HFO_LN_FILTER_EN = 0;
```

- The event update window is increased to 132ns, so set:

```
DpwmxRegs.DPWMEV1.all = 528; //normal mode
```

And also set EVENT3 if in multi mode:

```
DpwmxRegs.DPWMEV3.all = 528; //multi mode
```

In addition to above changes please make sure if any of changes listed in Table 1 and/or Table 2 are applicable to you.

## **4 Program Changes Required From UCD3138 to UCD3138A**

Almost all of the changes from the UCD3138 to the UCD3138A are enhancements which are controlled by new bits and new registers. There are 2 side-effect of enhancements which may require changes to UCD3138 code to make it run on the UCD3138A. There are also some unused features which have been deleted. This section describes all of these. If none of these features require a change, a UCD3138 object program should function correctly on a UCD3138A. Full testing on the UCD3138A is still required for verification, of course.

### **4.1 Increase in DPWM Event Update Window**

In order to support fixed frequency sampling in the LLC application, it was necessary to increase the event update window size to 132 ns. No DPWM edges can move in or out of the update window without risking distortion, long pulses, and/or shoot-through. In general this means that EVENT1 must be set to at least 132 ns. See the specific topologies sections above for recommendations. It is possible that EVENT1 will already be at or above 132 ns. In that case, no change is necessary.

In unusual topologies and when using multimode, make sure that no edge moves in and out of the event update window, which goes from 0 to 120 nanoseconds in the period. It is OK to have a fixed edge in the update window, just not one which moves.

### **4.2 Setting BLANK\_PCM\_EN bits for PCM**

The UCD3138A is more flexible for PCM (Peak Current Mode), but this flexibility requires that the DpwmxRegs.DPWMCTRL2.bit.BLANK\_PCM\_EN bits be set in all DPWM modules which provide blanking for the PCM logic. See the specific topology notes above for more information on which bits must be set. Generally this only applies for PCM projects.

### **4.3 Unused Bits and Modes Deleted on UCD3138A**

The following bits and modes were deleted in the UCD3138A, because they were unused in any known topologies, either at IT or at a customer. If they are used in any application, the program will have to be modified to work without them:

1. DPWMCTRL0:
  - a. MULTI\_MODE\_CLA\_A\_OFF and MULTI\_MODE\_CLA\_B\_OFF deleted
  - b. MASTER\_SYNC\_CNTL\_SEL deleted
  - c. SYNC\_CURR\_LIMIT\_EN deleted

- d. For information on these bits, see the UCD3138 Digital Power Peripherals Programmer's Manual.
  - e. All of the bits deleted return a 0 when read, and the system always acts the way a UCD3138 would act with a 0 value in those bits.
2. DPWMCTRL1 - EVENT\_UP\_SEL only has two modes – the update window only at the end of the period, or any time. The modes which use sample trigger 2 are removed.
  3. DPWMCTRL2
    - a. SAMPLE\_TRIG1\_MODE takes out modes 2 and 3
    - b. The RESON\_DEADTIME\_COMP\_EN bit is removed. It is always a zero, and the DPWM works the same as a UCD3138 with the bit as a zero.
  4. DPAMAUTOMID and DPWMAUTOMAX are the same as DPWMCTRL0 above, except that there is no MULTI\_MODE\_CLA\_A\_OFF bit to be removed.

## 5 Bits Which No Longer Need to Be Written To

There are several bits which had to be written to on the UCD3138 which no longer need to be written to on the UCD3138A. They have either been removed altogether, or they are already set to the correct state.

1. It is no longer necessary to include MiscAnalogRegs.CLKTRIM.bit.HFO\_LN\_FILTER\_EN = 0; The bit is already cleared by default.
2. DPWMCTRL1 – ALL\_PHASE\_CLK\_ENA is no longer present. All phases are always enabled. In the UCD3138A, it was recommended that ALL\_PHASE\_CLK\_ENA be set always.

## 6 Enhancements Which Require Firmware Changes

There are many enhancements which can be used when migrating to the UCD3138A.

### 6.1 Communication peripherals

#### 6.1.1 *UART Hardware Support for Auto Baud and Increased Baud Rate Resolution*

Power supply controllers typically use temperature compensated RC based oscillators. Despite the temperature compensation, the clock speed will change with temperature. This can lead to a difference in baud rate between two controllers, leading to lost communication. The UCD3138A adds logic which can match the receive baud rate by measuring the bit timing of the incoming signal.

In addition, the UCD3138 increases the resolution of the baud rate adjustment. The UCD3138 has 512 ns resolution, while the UCD3138A adds 3 bits and provides 64 ns resolution on the baud rate. This makes the use of auto baud possible at higher baud rates.

For detailed implementation Please refer to Application Note XXX.

### **6.1.2 PMBus supports 1 MHz bus speed.**

The UCD3138 was rated for a maximum of 400 kHz on the PMBus. The UCD3138 will support the 1 MHz version of the PMBus specification. Note that lower pull-up resistors may be required to support the higher speed. Consult the UCD3138A data sheet for specific timing specifications and drive capability.

### **6.1.3 Improved Clock High Timeout Handling**

Reading the CLK\_HIGH\_TIMEOUT bit was not recommended in the earlier devices. On the UCD3138A, this bit in the PMBST register will go high if the clock stays high for more than 55 milliseconds in the middle of a message. There is an added bit in the PMBINTM register as well to enable an interrupt for clock high timeout. There is also a CLK\_HI\_EN bit added to PMBCTRL3 which enables clock high timeout. The default for CLK\_HI\_EN is 0 to make the default performance the same as the UCD3138.

### **6.1.4 Improved Bit Counter Reset for Interrupted/Corrupted Messages**

On the UCD3138A, messages can be stopped in the middle of a byte and the PMBus will recover. Anything which resets the PMBus state machine now resets the bit counter as well. Events which reset the state machine include: Start, Stop, Clock High Timeout, Clock Low Timeout, and setting the RESET bit in PMBCTRL3.

## **6.2 Power Peripherals**

### **6.2.1 LLC Now Permits Fixed Frequency Sampling**

On the UCD3138, the front end had to sample at the variable LLC frequency to avoid shoot-through (pulse extension). With the UCD3138A, it is possible to sample at a fixed frequency without shoot through. This means that the control filter characteristics stay the same regardless of the LLC frequency.

### **6.2.2 DPWM B Reactivation After Fault Without Shutting Down DPWM A**

Both the '38 and '38A support using a fault signal to automatically shut down only DPWM B, without shutting down DPWM A. DPWM B is typically used for SR (Synchronous Rectification). On the '38, to restart DPWM B, it is necessary to disable the DPWM, which also shuts down DPWM A. On the '38A, the FLT\_RESTART bit is added to the DPWMFLTCTRL register. Setting this bit will restart DPWM B after a fault without stopping DPWM A. It can also be used to restart DPWM A without stopping DPWM B. Note that FLT\_RESTART does not reset itself. When using it, it is necessary to return it to zero after each use so that there will be a rising edge to trigger the next restart.

### **6.2.3 DPWM Interrupt Disabled when DPWM Disabled to Clear Fault**

On the UCD3138, it is necessary to disable the DPWM interrupt before disabling the DPWM to clear a fault. When the DPWM is disabled with the interrupt enabled, it will generate a continuous interrupt. On the UCD3138A, disabling the DPWM will cause DPWM interrupts to stop until the DPWM is enabled again.

### **6.2.4 Any Front End Can be Used for PCM**

On the UCD3138A, only Front End 2 could be used for PCM, because only FE2 supported the special PCM blanking. Now all front ends support the blanking.

The BLANK\_PCM\_EN bit in DPWMCTRL2 provides improved blanking of noise spikes in the Peak Current Mode comparator signal path. PCM blanking provides an earlier blanking than the blanking using the Blank A and Blank B enable bits on DPWM modules when used for PCM. It also makes it possible to use blanking signals from multiple DPWMs for all DPWMs.

When Blank A enable bit in a DPWM module is used, the blanking signal from the DPWM is 'and'ed with the CBC signal in the DPWM logic. This means that the CBC signal must first propagate through the PCM module and then through the Fault Mux before it arrives at the DPWM for blanking. It also means that the only blanking signals available are Blank A and Blank B from that DPWM. With PSFB (Phase Shifted Full Bridge), only Blank A is available, because Blank B is being used to generate a waveform.

With the BLANK\_PCM\_EN bit set, the blanking signal is sent to the PCM module, so it can be 'and'ed much sooner in the signal path. The latency from input to DPWM shut off is not changed, but the signal blanking interval is much closer to the actual interval from the blanking registers. This makes the blanking calculation easier. In addition, all the blanking signals are combined in the PCM module, so up to 8 blanking intervals can be applied to the CBC signal to all the DPWMs.

Here is the block diagram:

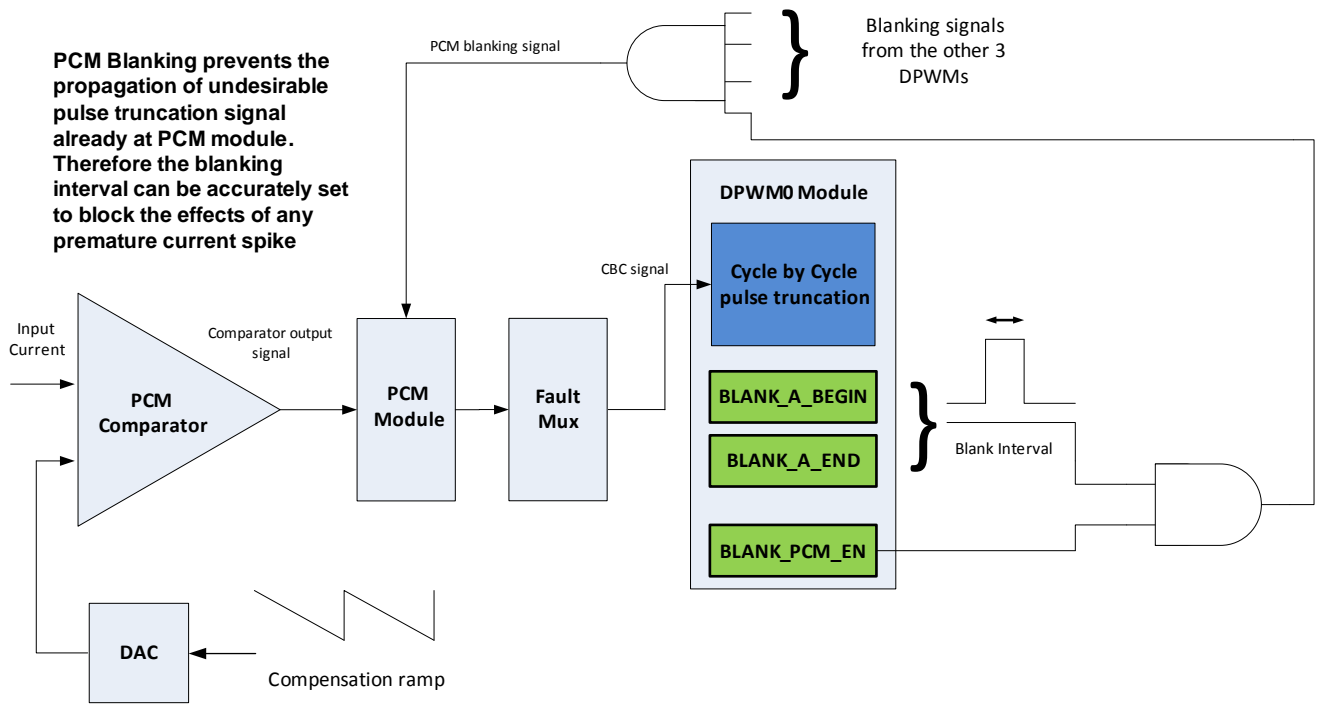

Here is the relative timing with and without BLANK\_PCM\_EN:

**With PCM Blanking**

The blanking time interval should cover the current spike's occurrence (plus some margining)

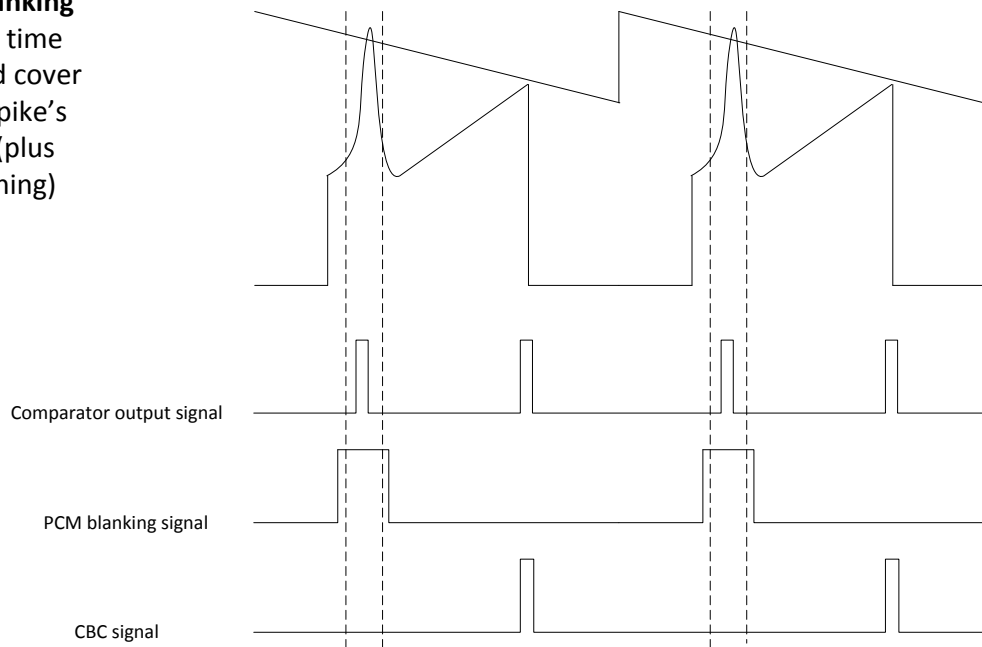

**With DPWM Blanking**

The blanking time calculation needs to take into account the CBC signal propagation delays

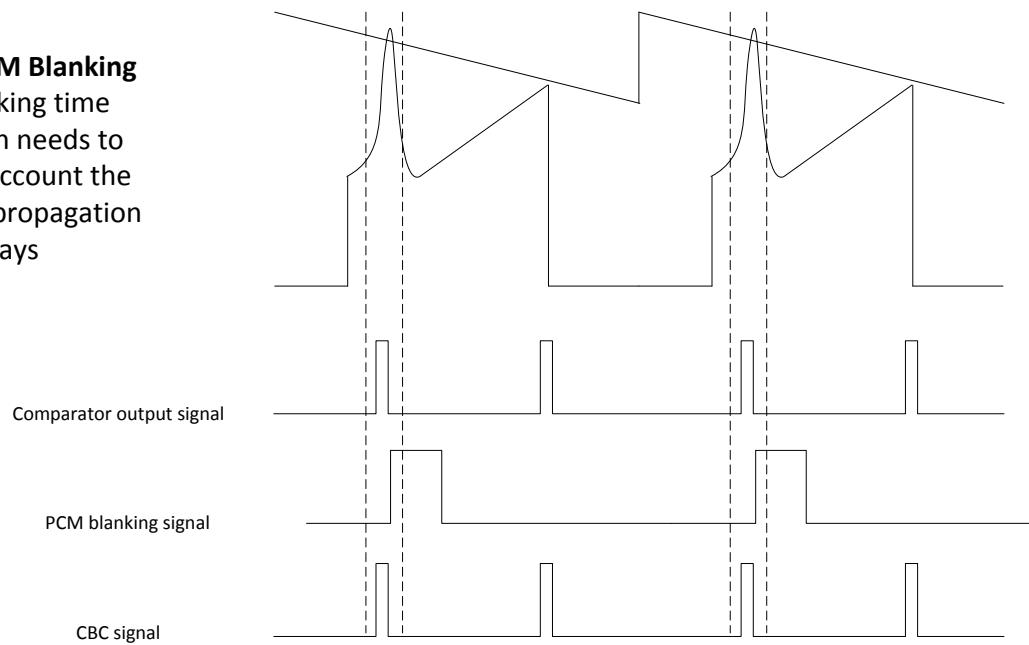



### **6.2.5 Fault Counter Changes from 5 to 7 Bits**

The UCD31XX family has sophisticated fault handling logic. For a detailed description of this logic, see the UCD3138 Digital Power Peripherals Programmer's Manual.

There are several fault signals which latch off the DPWM when a fault occurs. All of these fault signals have a count value in a register. For the fault to be triggered, x consecutive switching cycles have to have the fault signal occur, where x is the value in the count register plus 1. On the UCD3138 the maximum count value is 32. On the UCD3138A the maximum value is 128, except for the CBC fault, where the maximum value is 64.

### **6.2.6 Blanking for the Cycle by Cycle Fault Added**

In addition to the faults described above, there is also one signal called CBC (Cycle By Cycle), which turns the DPWM off for the remainder of the switching cycle, but permits it to turn on again at the beginning of the next cycle. Unlike the faults, the CBC does not latch the DPWM off permanently. This signal is typically used for current limiting, but is also used for peak current mode.

The CBC signal can be blanked with 2 blanking periods set by the blank a and blank b registers in the DPWM.

There is also something called the CBC fault. The CBC fault uses the same CBC signal which is used for the CBC non-latching DPWM shutdown. The CBC fault, however, has a count register and will latch the DPWM off when the count is exceeded. This is useful for two stage current limiting. The non-latching CBC can be used for a short time, but if it happens for (for example) for 50 consecutive switching cycles, the CBC fault can be used to latch the DPWM off.

On the UCD3138, the blanking only works on the non-latching CBC logic. The latching CBC fault has no blanking. With the UCD3138A, setting the new CBC\_FAULT\_MODE bit in the DPWMFLTCTRL register enables blanking for the CBC fault too. Leaving CBC\_FAULT\_MODE as the default zero value makes the UCD3138A function just like the other UCD31xx parts, with no blanking for the latched CBC fault.

### **6.2.7 Improved Fault and Burst Mode with Edge Generator in Use**

On the UCD3138, the fault logic worked on the DPWM outputs before the edge generator logic. This meant that sometimes one of the 4 FET control lines for PSFB (Phase Switching Full Bridge) would not be turned off right away, and firmware would be required to turn it off. The same was true of the hardware burst or light load mode. When the burst was over, sometimes one of the lines would not be turned off automatically.

Now the fault logic has been extended past the edge generation logic, so that all 4 lines are turned off immediately by a fault or by burst mode. There are no register changes associated with this enhancement.

### **6.2.8 DAC Dither on Sample Trigger**

The UCD3138A adds a new bit in the EADC DAC register called DAC\_DITHER\_ON\_SAMPLE. This bit causes the EADC DAC to dither on the sample trigger. Normally the DAC dithers on the frame sync, so dither takes place only once every switching cycle. This means that the dither frequency will be 1/16<sup>th</sup> the switching frequency. If the sample trigger is set to oversample, the dither could move to 8, 4, or 2 times the switching frequency, providing faster dither, with the full 16 dither steps taking place in as little as 2 switching cycles.

## **6.3 ADC12**

### **6.3.1 Sample and Hold Buffer Available on ADC even if Sample and Hold are Not Used**

The ADC12 has a small capacitor which is charged at the beginning of every sample. This means that the output impedance of anything driving the ADC has to be relatively low to ensure ADC accuracy. The sample and hold feature requires a larger sample and hold capacitor to be charged to retain the voltage until the next sampling cycle. This is done to provide simultaneous sampling for functions like power measurement.

This function works exactly the same on the UCD3138A as it does on the earlier models of the UCD31xx.

On the UCD3138A, it is possible to use the buffer even if the sample and hold function is not being used. This makes it possible to use 1 of 3 ADC inputs for a voltage source with a higher impedance. To use this, there are several steps:

1. Select the ADC channel which will be buffered by writing to the BYPASS\_EN bits in ADCCTRL.
  - a. 011 = Channel 2
  - b. 101 = Channel 1
  - c. 110 = Channel 0
2. Make sure that there are no SEQx\_SH bits set
3. Set the ADC\_SH\_BUFFER\_EN bit in ADCTSTCTRL

This should provide a buffer on the selected channel, but no sample and hold functionality.

Note that the ADC\_SH\_BUFFER cannot read all the way down to 0 volts. See the UCD3138A data sheet for detailed specifications.

### **6.3.2 ADC Stop Sequence Capability**

On the UCD3138, it was not possible to stop an ADC sequence in the middle, reload the sequence registers and restart right away measuring the new sequence. In the UCD3138A, this is possible. The sequence is:

1. Clear the ADC\_EN bit.
2. Write the new values to the sequence select registers
3. Set the ADC\_EN bit
4. Clear and set the SW\_START bit to start the new sequence.

## **6.4 Oscillator**

### **6.4.1 HFO Trim Bit Field Linearity**

The UCD3138A is designed to make it possible to change the clock speed for the processor and the peripherals. The main clock is called the HFO (High Frequency Oscillator), and all other clocks except for the RTC are derived from the HFO.

There are two clock speed control bitfields, HFO\_FINE\_TRIM and HFO\_COARSE\_TRIM. Here is how to write to them:

```
MiscAnalogRegs.CLKTRIM.bit.HFO_COARSE_TRIM = x;  
MiscAnalogRegs.CLKTRIM.bit.HFO_FINE_TRIM = y;
```

When each device is tested, the correct values for these registers are determined. The device will power up with the optimal values. By adjusting the trim registers and comparing the HFO clock to the RTC clock or some other precise reference, it is possible to make the clock more accurate over the temperature range.

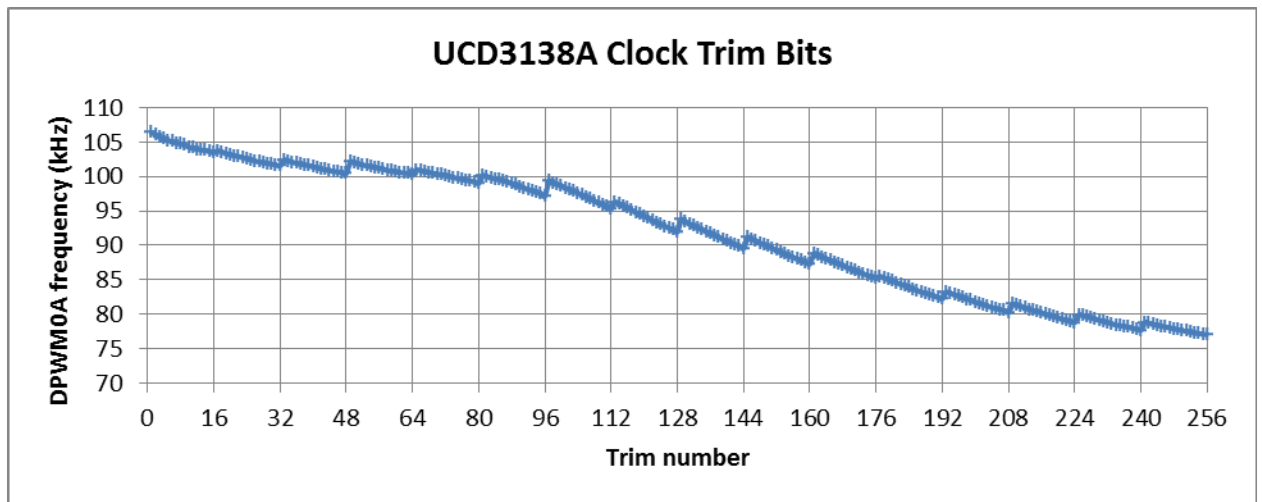

The coarse and fine trim registers are monotonic as individual registers, but the same does not apply if the coarse and fine trim registers are used together. The range of the fine trim register is bigger than the size of a coarse trim register step. And the two registers will not necessarily align the same way on different devices. Any firmware which modifies the clock trim fields will have to take this into account. The graph below shows an example of clock speed variation. The vertical axis is DPWM frequency with a nominal value of 100 KHz. The horizontal axis is a number which combines fine and coarse trim into one. Every 16 steps, the fine trim goes from its minimum to its maximum value, and the coarse trim is incremented by 1. Since the fine trim overlaps more than 1 coarse trim step, there is a non-monotonicity in the combined numbers. Clock adjustment firmware needs to account for this variation.

The clock oscillator is compensated for temperature. This means that it remains relatively constant over temperature. It also means that different devices will have different curves over temperature. The curves of clock frequency vs temperature are not consistent enough between devices to make adjusting clock trim with temperature a useful strategy for clock regulation.

#### 6.4.2 HFO Low Noise Filter Disabled Automatically

The clock filter logic has also been changed, so it is no longer necessary to put this statement into the program:

```
MiscAnalogRegs.CLKTRIM.bit.HFO_LN_FILTER_EN = 0;
```

The clock filter is handled as part of the trim process, and should not be modified by the firmware.

#### 6.5 JTAG/Boot ROM – JTAG Enabled in ROM mode

On the UCD3138, if JTAG operation is desired in ROM mode, it is necessary to write to the IOMUX register to enable JTAG. On the UCD3138A, if there is not a valid checksum and ROM mode is entered, the JTAG pins are automatically enabled.

## **7 Hardware/Board Changes**

### **7.1 Improved ADC Accuracy at lower temperature**

The UCD3138A provides improved ADC accuracy (INL) at temperatures below 0 C. Consult the data sheet for the UCD3138A for the latest data.

### **7.2 Need for V33/BP18 Capacitor Eliminated**

The UCD3138 requires a capacitor between V33 and BP18 to ensure that the DPWM pins stay low or high impedance during power up. On the UCD3138A, this is not necessary. Changes have been made to the DPWM logic to ensure that the DPWM pins do not drive high during power up. As the 3.3 V supply comes up, the DPWM pins will go from high impedance to active pull down even if the 1.8 volt internal bias has not ramped up yet.

### **7.3 Reduction in Offset Required for PCM Comparator**

In PCM on the UCD3138, the PCM comparator can require up to 100 mV before it responds to an input signal. On the UCD3138A, the maximum requirement is only 30 mV. Check the UCD3138A data sheet for the latest values.

### **7.4 Hysteresis Added to Auto Gear Shift AFE Gain Switching**

The UCD3138 has a mode where it automatically switches the AFE gain to maximize both resolution and dynamic range. On the UCD3138, Front Ends 0 and 1 switched the AFE gain lower by a factor of 2 when the EADC was out of range at the current gain. As soon as the EADC input dropped to half scale, the gain would be switched back down. This meant that the switching point for up and down was at the same point. If the voltage was at this point, the AFE gain would oscillate. Front End 2 on the UCD3138 switches up at the same point, but it doesn't switch down until the EADC is at 3/8 of full range. On the UCD3138A, all 3 front ends switch the way Front End 2 does on the UCD3138.

### **7.5 Migration from RHA package to RMH package.**

## **References**

The style "References Text" is used for the text below. You must manually apply the italics to the document title, as shown below. If you are referencing a TI document, include the basic literature number (with no revision letter) in parentheses after the title.

## Appendix A. UCD3138A Peripheral Registers Reference

### A.1 Loop Mux Registers

#### A.1.1 Front End Control 0 Mux Register (FECTRL0MUX)

Address 00020000

Bit Number	13:12	11
Bit Name	NL_SEL	DPWM3_FRAME_SYNC_EN
Access	R/W	R/W
Default	00	0

Bit Number	10	9
Bit Name	DPWM2_FRAME_SYNC_EN	DPWM1_FRAME_SYNC_EN
Access	R/W	R/W
Default	0	0

Bit Number	8	7	6
Bit Name	DPWM0_FRAME_SYNC_EN	DPWM3_B_TRIG_EN	DPWM2_B_TRIG_EN
Access	R/W	R/W	R/W
Default	0	0	0

Bit Number	5	4	3
Bit Name	DPWM1_B_TRIG_EN	DPWM0_B_TRIG_EN	DPWM3_A_TRIG_EN
Access	R/W	R/W	R/W
Default	0	0	0

Bit Number	2	1	0
Bit Name	DPWM2_A_TRIG_EN	DPWM1_A_TRIG_EN	DPWM0_A_TRIG_EN
Access	R/W	R/W	R/W
Default	0	0	0

**Bits 13-12: NL\_SEL** – Configures source of Non-Linear (NL) comparison results used in Automatic Gain Shifting

- 0 = Filter 0 NL Results used
- 1 = Filter 1 NL Results used
- 2 = Filter 2 NL Results used (Default)

**Bit 11: DPWM3\_FRAME\_SYNC\_EN** – Enables DPWM Trigger from DPWM 3 Frame Sync to Front End Control

- 0 = DPWM 3 Frame Sync not routed to Front End Control (Default)
- 1 = DPWM 3 Frame Sync routed to Front End Control

**Bit 10: DPWM2\_FRAME\_SYNC\_EN** – Enables DPWM Trigger from DPWM 2 Frame Sync to Front End Control

- 0 = DPWM 2 Frame Sync not routed to Front End Control (Default)
- 1 = DPWM 2 Frame Sync routed to Front End Control

**Bit 9: DPWM1\_FRAME\_SYNC\_EN** – Enables DPWM Trigger from DPWM 1 Frame Sync to Front End Control

- 0 = DPWM 1 Frame Sync not routed to Front End Control (Default)
- 1 = DPWM 1 Frame Sync routed to Front End Control

- Bit 8: DPWM0\_FRAME\_SYNC\_EN** – Enables DPWM Trigger from DPWM 0 Frame Sync to Front End Control
- 0 = DPWM 0 Frame Sync not routed to Front End Control (Default)  
1 = DPWM 0 Frame Sync routed to Front End Control
- Bit 7: DPWM3\_B\_TRIG\_EN** – Enables DPWM Trigger from DPWM 3 PWM-B to Front End Control
- 0 = DPWM 3 PWM-B lowres not routed to Front End Control
- (Default)  
1 = DPWM 3 PWM-B lowres routed to Front End Control
- Bit 6: DPWM2\_B\_TRIG\_EN** – Enables DPWM Trigger from DPWM 2 PWM-B to Front End Control
- 0 = DPWM 2 PWM-B lowres not routed to Front End Control
- (Default)  
1 = DPWM 2 PWM-B lowres routed to Front End Control
- Bit 5: DPWM1\_B\_TRIG\_EN** – Enables DPWM Trigger from DPWM 1 PWM-B to Front End Control
- 0 = DPWM 1 PWM-B lowres not routed to Front End Control
- (Default)  
1 = DPWM 1 PWM-B lowres routed to Front End Control
- Bit 4: DPWM0\_B\_TRIG\_EN** – Enables DPWM Trigger from DPWM 0 PWM-B to Front End Control
- 0 = DPWM 0 PWM-B lowres not routed to Front End Control
- (Default)  
1 = DPWM 0 PWM-B lowres routed to Front End Control
- Bit 3: DPWM3\_A\_TRIG\_EN** – Enables DPWM Trigger from DPWM 3 PWM-A to Front End Control
- 0 = DPWM 3 PWM-A lowres not routed to Front End Control
- (Default)  
1 = DPWM 3 PWM-A lowres routed to Front End Control
- Bit 2: DPWM2\_A\_TRIG\_EN** – Enables DPWM Trigger from DPWM 2 PWM-A to Front End Control
- 0 = DPWM 2 PWM-A lowres not routed to Front End Control
- (Default)  
1 = DPWM 2 PWM-A lowres routed to Front End Control
- Bit 1: DPWM1\_A\_TRIG\_EN** – Enables DPWM Trigger from DPWM 1 PWM-A to Front End Control
- 0 = DPWM 1 PWM-A lowres not routed to Front End Control
- (Default)  
1 = DPWM 1 PWM-A lowres routed to Front End Control
- Bit 0: DPWM0\_A\_TRIG\_EN** – Enables DPWM Trigger from DPWM 0 PWM-A to Front End Control
- 0 = DPWM 0 PWM-A lowres not routed to Front End Control
- (Default)  
1 = DPWM 0 PWM-A lowres routed to Front End Control

### A.1.2 Front End Control 1 Mux Register (FECTRL1MUX)

Address 00020004

Bit Number	13:12	11
Bit Name	NL_SEL	DPWM3_FRAME_SYNC_EN
Access	R/W	R/W
Default	01	0

Bit Number	10	9
Bit Name	DPWM2_FRAME_SYNC_EN	DPWM1_FRAME_SYNC_EN
Access	R/W	R/W
Default	0	0

Bit Number	8	7	6
Bit Name	DPWM0_FRAME_SYNC_EN	DPWM3_B_TRIG_EN	DPWM2_B_TRIG_EN
Access	R/W	R/W	R/W
Default	0	0	0

Bit Number	5	4	3
Bit Name	DPWM1_B_TRIG_EN	DPWM0_B_TRIG_EN	DPWM3_A_TRIG_EN
Access	R/W	R/W	R/W
Default	0	0	0

Bit Number	2	1	0
Bit Name	DPWM2_A_TRIG_EN	DPWM1_A_TRIG_EN	DPWM0_A_TRIG_EN
Access	R/W	R/W	R/W
Default	0	0	0

**Bits 13-12: NL\_SEL** – Configures source of Non-Linear (NL) comparison results used in Automatic Gain Shifting

- 0 = Filter 0 NL Results used
- 1 = Filter 1 NL Results used
- 2 = Filter 2 NL Results used (Default)

**Bit 11: DPWM3\_FRAME\_SYNC\_EN** – Enables DPWM Trigger from DPWM 3 Frame Sync to Front End Control

- 0 = DPWM 3 Frame Sync not routed to Front End Control (Default)
- 1 = DPWM 3 Frame Sync routed to Front End Control

**Bit 10: DPWM2\_FRAME\_SYNC\_EN** – Enables DPWM Trigger from DPWM 2 Frame Sync to Front End Control

- 0 = DPWM 2 Frame Sync not routed to Front End Control (Default)
- 1 = DPWM 2 Frame Sync routed to Front End Control

**Bit 9: DPWM1\_FRAME\_SYNC\_EN** – Enables DPWM Trigger from DPWM 1 Frame Sync to Front End Control

- 0 = DPWM 1 Frame Sync not routed to Front End Control (Default)
- 1 = DPWM 1 Frame Sync routed to Front End Control

**Bit 8: DPWM0\_FRAME\_SYNC\_EN** – Enables DPWM Trigger from DPWM 0 Frame Sync to Front End Control

- 0 = DPWM 0 Frame Sync not routed to Front End Control (Default)
- 1 = DPWM 0 Frame Sync routed to Front End Control



- Bit 7: DPWM3\_B\_TRIG\_EN** – Enables DPWM Trigger from DPWM 3 PWM-B to Front End Control  
(Default) 0 = DPWM 3 PWM-B lowres not routed to Front End Control  
1 = DPWM 3 PWM-B lowres routed to Front End Control
- Bit 6: DPWM2\_B\_TRIG\_EN** – Enables DPWM Trigger from DPWM 2 PWM-B to Front End Control  
(Default) 0 = DPWM 2 PWM-B lowres not routed to Front End Control  
1 = DPWM 2 PWM-B lowres routed to Front End Control
- Bit 5: DPWM1\_B\_TRIG\_EN** – Enables DPWM Trigger from DPWM 1 PWM-B to Front End Control  
(Default) 0 = DPWM 1 PWM-B lowres not routed to Front End Control  
1 = DPWM 1 PWM-B lowres routed to Front End Control
- Bit 4: DPWM0\_B\_TRIG\_EN** – Enables DPWM Trigger from DPWM 0 PWM-B to Front End Control  
(Default) 0 = DPWM 0 PWM-B lowres not routed to Front End Control  
1 = DPWM 0 PWM-B lowres routed to Front End Control
- Bit 3: DPWM3\_A\_TRIG\_EN** – Enables DPWM Trigger from DPWM 3 PWM-A to Front End Control  
(Default) 0 = DPWM 3 PWM-A lowres not routed to Front End Control  
1 = DPWM 3 PWM-A lowres routed to Front End Control
- Bit 2: DPWM2\_A\_TRIG\_EN** – Enables DPWM Trigger from DPWM 2 PWM-A to Front End Control  
(Default) 0 = DPWM 2 PWM-A lowres not routed to Front End Control  
1 = DPWM 2 PWM-A lowres routed to Front End Control
- Bit 1: DPWM1\_A\_TRIG\_EN** – Enables DPWM Trigger from DPWM 1 PWM-A to Front End Control  
(Default) 0 = DPWM 1 PWM-A lowres not routed to Front End Control  
1 = DPWM 1 PWM-A lowres routed to Front End Control
- Bit 0: DPWM0\_A\_TRIG\_EN** – Enables DPWM Trigger from DPWM 0 PWM-A to Front End Control  
(Default) 0 = DPWM 0 PWM-A lowres not routed to Front End Control  
1 = DPWM 0 PWM-A lowres routed to Front End Control

### A.1.3 Front End Control 2 Mux Register (FECTRL2MUX)

Address 00020008

Bit Number	13:12	11
Bit Name	NL_SEL	DPWM3_FRAME_SYNC_EN
Access	R/W	R/W
Default	10	0

Bit Number	10	9
Bit Name	DPWM2_FRAME_SYNC_EN	DPWM1_FRAME_SYNC_EN
Access	R/W	R/W
Default	0	0

Bit Number	8	7	6
Bit Name	DPWM0_FRAME_SYNC_EN	DPWM3_B_TRIG_EN	DPWM2_B_TRIG_EN
Access	R/W	R/W	R/W
Default	0	0	0

Bit Number	5	4	3
Bit Name	DPWM1_B_TRIG_EN	DPWM0_B_TRIG_EN	DPWM3_A_TRIG_EN
Access	R/W	R/W	R/W
Default	0	0	0

Bit Number	2	1	0
Bit Name	DPWM2_A_TRIG_EN	DPWM1_A_TRIG_EN	DPWM0_A_TRIG_EN
Access	R/W	R/W	R/W
Default	0	0	0

**Bits 13-12: NL\_SEL** – Configures source of Non-Linear (NL) comparison results used in Automatic Gain Shifting

- 0 = Filter 0 NL Results used
- 1 = Filter 1 NL Results used
- 2 = Filter 2 NL Results used (Default)

**Bit 11: DPWM3\_FRAME\_SYNC\_EN** – Enables DPWM Trigger from DPWM 3 Frame Sync to Front End Control

- 0 = DPWM 3 Frame Sync not routed to Front End Control (Default)
- 1 = DPWM 3 Frame Sync routed to Front End Control

**Bit 10: DPWM2\_FRAME\_SYNC\_EN** – Enables DPWM Trigger from DPWM 2 Frame Sync to Front End Control

- 0 = DPWM 2 Frame Sync not routed to Front End Control (Default)
- 1 = DPWM 2 Frame Sync routed to Front End Control

**Bit 9: DPWM1\_FRAME\_SYNC\_EN** – Enables DPWM Trigger from DPWM 1 Frame Sync to Front End Control

- 0 = DPWM 1 Frame Sync not routed to Front End Control (Default)
- 1 = DPWM 1 Frame Sync routed to Front End Control

**Bit 8: DPWM0\_FRAME\_SYNC\_EN** – Enables DPWM Trigger from DPWM 0 Frame Sync to Front End Control

- 0 = DPWM 0 Frame Sync not routed to Front End Control (Default)
- 1 = DPWM 0 Frame Sync routed to Front End Control

- Bit 7: DPWM3\_B\_TRIG\_EN** – Enables DPWM Trigger from DPWM 3 PWM-B to Front End Control  
(Default) 0 = DPWM 3 PWM-B lowres not routed to Front End Control  
1 = DPWM 3 PWM-B lowres routed to Front End Control
- Bit 6: DPWM2\_B\_TRIG\_EN** – Enables DPWM Trigger from DPWM 2 PWM-B to Front End Control  
(Default) 0 = DPWM 2 PWM-B lowres not routed to Front End Control  
1 = DPWM 2 PWM-B lowres routed to Front End Control
- Bit 5: DPWM1\_B\_TRIG\_EN** – Enables DPWM Trigger from DPWM 1 PWM-B to Front End Control  
(Default) 0 = DPWM 1 PWM-B lowres not routed to Front End Control  
1 = DPWM 1 PWM-B lowres routed to Front End Control
- Bit 4: DPWM0\_B\_TRIG\_EN** – Enables DPWM Trigger from DPWM 0 PWM-B to Front End Control  
(Default) 0 = DPWM 0 PWM-B lowres not routed to Front End Control  
1 = DPWM 0 PWM-B lowres routed to Front End Control
- Bit 3: DPWM3\_A\_TRIG\_EN** – Enables DPWM Trigger from DPWM 3 PWM-A to Front End Control  
(Default) 0 = DPWM 3 PWM-A lowres not routed to Front End Control  
1 = DPWM 3 PWM-A lowres routed to Front End Control
- Bit 2: DPWM2\_A\_TRIG\_EN** – Enables DPWM Trigger from DPWM 2 PWM-A to Front End Control  
(Default) 0 = DPWM 2 PWM-A lowres not routed to Front End Control  
1 = DPWM 2 PWM-A lowres routed to Front End Control
- Bit 1: DPWM1\_A\_TRIG\_EN** – Enables DPWM Trigger from DPWM 1 PWM-A to Front End Control  
(Default) 0 = DPWM 1 PWM-A lowres not routed to Front End Control  
1 = DPWM 1 PWM-A lowres routed to Front End Control
- Bit 0: DPWM0\_A\_TRIG\_EN** – Enables DPWM Trigger from DPWM 0 PWM-A to Front End Control  
(Default) 0 = DPWM 0 PWM-A lowres not routed to Front End Control  
1 = DPWM 0 PWM-A lowres routed to Front End Control

### A.1.4 Sample Trigger Control Register (SAMPTRIGCTRL)

Address 0002000C

Bit Number	11	10	9
Bit Name	FE2_TRIG_DPWM3_EN	FE2_TRIG_DPWM2_EN	FE2_TRIG_DPWM1_EN
Access	R/W	R/W	R/W
Default	0	0	0

Bit Number	8	7	6
Bit Name	FE2_TRIG_DPWM0_EN	FE1_TRIG_DPWM3_EN	FE1_TRIG_DPWM2_EN
Access	R/W	R/W	R/W
Default	0	0	0

Bit Number	5	4	3
Bit Name	FE1_TRIG_DPWM1_EN	FE1_TRIG_DPWM0_EN	FE0_TRIG_DPWM3_EN
Access	R/W	R/W	R/W
Default	0	0	0

Bit Number	2	1	0
Bit Name	FE0_TRIG_DPWM2_EN	FE0_TRIG_DPWM1_EN	FE0_TRIG_DPWM0_EN
Access	R/W	R/W	R/W
Default	0	0	0

**Bit 11: FE2\_TRIG\_DPWM3\_EN** – Enables Sample Trigger from DPWM 3 to Front End Control 2

(Default) 0 = DPWM 3 Sample Trigger not routed to Front End Control 2

1 = DPWM 3 Sample Trigger routed to Front End Control 2

**Bit 10: FE2\_TRIG\_DPWM2\_EN** – Enables Sample Trigger from DPWM 2 to Front End Control 2

(Default) 0 = DPWM 2 Sample Trigger not routed to Front End Control 2

1 = DPWM 2 Sample Trigger routed to Front End Control 2

**Bit 9: FE2\_TRIG\_DPWM1\_EN** – Enables Sample Trigger from DPWM 1 to Front End Control 2

(Default) 0 = DPWM 1 Sample Trigger not routed to Front End Control 2

1 = DPWM 1 Sample Trigger routed to Front End Control 2

**Bit 8: FE2\_TRIG\_DPWM0\_EN** – Enables Sample Trigger from DPWM 0 to Front End Control 2

(Default) 0 = DPWM 0 Sample Trigger not routed to Front End Control 2

1 = DPWM 0 Sample Trigger routed to Front End Control 2

**Bit 7: FE1\_TRIG\_DPWM3\_EN** – Enables Sample Trigger from DPWM 3 to Front End Control 1

(Default) 0 = DPWM 3 Sample Trigger not routed to Front End Control 1

1 = DPWM 3 Sample Trigger routed to Front End Control 1

**Bit 6: FE1\_TRIG\_DPWM2\_EN** – Enables Sample Trigger from DPWM 2 to Front End Control 1

0 = DPWM 2 Sample Trigger not routed to Front End Control 1

(Default)

1 = DPWM 2 Sample Trigger routed to Front End Control 1

**Bit 5: FE1\_TRIG\_DPWM1\_EN** – Enables Sample Trigger from DPWM 1 to Front End Control 1

0 = DPWM 1 Sample Trigger not routed to Front End Control 1

(Default)

1 = DPWM 1 Sample Trigger routed to Front End Control 1

**Bit 4: FE1\_TRIG\_DPWM0\_EN** – Enables Sample Trigger from DPWM 0 to Front End Control 1

0 = DPWM 0 Sample Trigger not routed to Front End Control 1

(Default)

1 = DPWM 0 Sample Trigger routed to Front End Control 1

**Bit 3: FE0\_TRIG\_DPWM3\_EN** – Enables Sample Trigger from DPWM 3 to Front End Control 0

0 = DPWM 3 Sample Trigger not routed to Front End Control 0

(Default)

1 = DPWM 3 Sample Trigger routed to Front End Control 0

**Bit 2: FE0\_TRIG\_DPWM2\_EN** – Enables Sample Trigger from DPWM 2 to Front End Control 0

0 = DPWM 2 Sample Trigger not routed to Front End Control 0

(Default)

1 = DPWM 2 Sample Trigger routed to Front End Control 0

**Bit 1: FE0\_TRIG\_DPWM1\_EN** – Enables Sample Trigger from DPWM 1 to Front End Control 0

0 = DPWM 1 Sample Trigger not routed to Front End Control 0

(Default)

1 = DPWM 1 Sample Trigger routed to Front End Control 0

**Bit 0: FE0\_TRIG\_DPWM0\_EN** – Enables Sample Trigger from DPWM 0 to Front End Control 0

0 = DPWM 0 Sample Trigger not routed to Front End Control 0

(Default)

1 = DPWM 0 Sample Trigger routed to Front End Control 0

### A.1.5 External DAC Control Register (*EXTDACCTRL*)

Address 00020010

Bit Number	26:24	23:19	18:16	15:11	10:8
Bit Name	DAC2_SEL	RESERVED	DAC1_SEL	RESERVED	DAC0_SEL
Access	R/W	-	R/W	-	R/W
Default	000	0_0000	000	0_0000	000

Bit Number	7:3	2	1	0
Bit Name	RESERVED	EXT_DAC2_EN	EXT_DAC1_EN	EXT_DAC0_EN
Access	-	R/W	R/W	R/W
Default	0_0000	0	0	0

**Bits 26-24: DAC2\_SEL** – Configures DAC 2 setpoint in External DAC Mode

0 = DAC 0 Setpoint Selected (Default)

1 = DAC 1 Setpoint Selected

3 = Output of Constant Power Module Selected

4 = Filter 0 Output Selected

5 = Filter 1 Output Selected

6 = Filter 2 Output Selected

**Bits 23-19: RESERVED** – Unused bits

**Bits 18-16: DAC1\_SEL** – Configures DAC 1 setpoint in External DAC Mode

- 0 = DAC 0 Setpoint Selected (Default)
- 2 = DAC 2 Setpoint Selected
- 3 = Output of Constant Power Module Selected
- 4 = Filter 0 Output Selected
- 5 = Filter 1 Output Selected
- 6 = Filter 2 Output Selected

**Bits 15-11: RESERVED** – Unused bits

**Bits 10-8: DAC0\_SEL** – Configures DAC 0 setpoint in External DAC Mode

- 1 = DAC 1 Setpoint Selected
- 2 = DAC 2 Setpoint Selected
- 3 = Output of Constant Power Module Selected
- 4 = Filter 0 Output Selected
- 5 = Filter 1 Output Selected
- 6 = Filter 2 Output Selected

**Bits 7-3: RESERVED** – Unused bits

**Bit 2: EXT\_DAC2\_EN** – External DAC 2 Mode Enable

- 0 = External DAC Mode disabled. DAC 2 setpoint driven from Front End Control Module (Default)
- 1 = External DAC Mode enabled, DAC 2 setpoint driven by DAC2\_SEL configuration

**Bit 1: EXT\_DAC1\_EN** – External DAC 1 Mode Enable

- 0 = External DAC Mode disabled. DAC 1 setpoint driven from Front End Control Module (Default)
- 1 = External DAC Mode enabled, DAC 1 setpoint driven by DAC1\_SEL configuration

**Bit 0: EXT\_DAC0\_EN** – External DAC 0 Mode Enable

- 0 = External DAC Mode disabled. DAC 0 setpoint driven from Front End Control Module (Default)
- 1 = External DAC Mode enabled, DAC 0 setpoint driven by DAC0\_SEL configuration

### A.1.6 Filter Mux Register (*FILTERMUX*)

Address 00020014

Bit Number	29:28	27:26	25:24
Bit Name	FILTER2_KCOMP_SEL	FILTER1_KCOMP_SEL	FILTER0_KCOMP_SEL
Access	R/W	R/W	R/W
Default	00	00	00

Bit Number	23:19	18	17	16
Bit Name	RESERVED	FILTER2_FFWD_SEL	FILTER1_FFWD_SEL	FILTER0_FFWD_SEL
Access	R/W	R/W	R/W	R/W
Default	0_0000	0	0	0

Bit Number	15:14	13:12	11:10	9:8
Bit Name	RESERVED	FILTER2_PER_SEL	FILTER1_PER_SEL	FILTER0_PER_SEL
Access	R/W	R/W	R/W	R/W
Default	00	00	00	00

Bit Number	7:6	5:4	3:2	1:0
Bit Name	RESERVED	FILTER2_FE_SEL	FILTER1_FE_SEL	FILTER0_FE_SEL
Access	-	R/W	R/W	R/W
Default	00	10	01	00

**Bits 29-28: FILTER2\_KCOMP\_SEL** – Selects KComp value routed to Filter 2 Module  
0 = KComp 0 Value Selected (Default)

1 = KComp 1 Value Selected  
2 = KComp 2 Value Selected

**Bits 27-26: FILTER1\_KCOMP\_SEL** – Selects KComp value routed to Filter 1 Module  
0 = KComp 0 Value Selected (Default)

1 = KComp 1 Value Selected  
2 = KComp 2 Value Selected

**Bits 25-24: FILTER0\_KCOMP\_SEL** – Selects KComp value routed to Filter 0 Module  
0 = KComp 0 Value Selected (Default)

1 = KComp 1 Value Selected  
2 = KComp 2 Value Selected

**Bits 23-19: RESERVED** – Unused bits

**Bit 18: FILTER2\_FFWD\_SEL** – Configures Feedforward value routed to Filter 2 Module  
0 = Filter 0 Output Selected (Default)

1 = Filter 1 Output Selected

**Bit 17: FILTER1\_FFWD\_SEL** – Configures Feedforward value routed to Filter 1 Module  
0 = Filter 0 Output Selected (Default)

1 = Filter 2 Output Selected

**Bit 16: FILTER0\_FFWD\_SEL** – Configures Feedforward value routed to Filter 0 Module  
0 = Filter 1 Output Selected (Default)

1 = Filter 2 Output Selected

**Bits 15-14: RESERVED** – Unused bits

**Bits 13-12: FILTER2\_PER\_SEL** – Selects source of switching cycle period for Filter 2 Module  
0 = DPWM 0 Switching Period (Default)

1 = DPWM 1 Switching Period  
2 = DPWM 2 Switching Period  
3 = DPWM 3 Switching Period

**Bits 11-10: FILTER1\_PER\_SEL** – Selects source of switching cycle period for Filter 1 Module

- 0 = DPWM 0 Switching Period (Default)
- 1 = DPWM 1 Switching Period
- 2 = DPWM 2 Switching Period
- 3 = DPWM 3 Switching Period

**Bits 9-8: FILTER0\_PER\_SEL** – Selects source of switching cycle period for Filter 0 Module

- 0 = DPWM 0 Switching Period (Default)
- 1 = DPWM 1 Switching Period
- 2 = DPWM 2 Switching Period
- 3 = DPWM 3 Switching Period

**Bits 7-6: RESERVED** – Unused bits

**Bits 5-4: FILTER2\_FE\_SEL** – Selects which Front End Module provides data for Filter 2 Module

- 0 = Front End Module 0 provides data to Filter
- 1 = Front End Module 1 provides data to Filter
- 2 = Front End Module 2 provides data to Filter (Default)

**Bits 3-2: FILTER1\_FE\_SEL** – Selects which Front End Module provides data for Filter 1 Module

- 0 = Front End Module 0 provides data to Filter
- 1 = Front End Module 1 provides data to Filter (Default)
- 2 = Front End Module 2 provides data to Filter

**Bits 1-0: FILTER0\_FE\_SEL** – Selects which Front End Module provides data for Filter 0 Module

- 0 = Front End Module 0 provides data to Filter (Default)
- 1 = Front End Module 1 provides data to Filter
- 2 = Front End Module 2 provides data to Filter



### A.1.7 Filter KComp A Register (*FILTERKCOMPA*)

Address 00020018

Bit Number	29:16	15:14	13:0
Bit Name	KCOMP1	RESERVED	KCOMP0
Access	R/W	-	R/W
Default	00_0000_0000_0000	00	00_0000_0111_1101

**Bits 29-16: KCOMP1** – 14-bit value used in filter output calculations replacing the DPWM switching period value

**Bits 15-14: RESERVED** – Unused bits

**Bits 13-0: KCOMP0** – 14-bit value used in filter output calculations replacing the DPWM switching period value

### A.1.8 Filter KComp B Register (*FILTERKCOMPB*)

Address 0002001C

Bit Number	13:0
Bit Name	KCOMP2
Access	R/W
Default	00_0000_0000_0000

**Bits 13-0: KCOMP2** – 14-bit value used in filter output calculations replacing the DPWM switching period value

### A.1.9 DPWM Mux Register (DPWMMUX)

Address 00020020

Bit Number	31:30	29:28
Bit Name	DPWM3_SYNC_FET_SEL	DPWM2_SYNC_FET_SEL
Access	R/W	R/W
Default	00	00

Bit Number	27:26	25:24
Bit Name	DPWM1_SYNC_FET_SEL	DPWM0_SYNC_FET_SEL
Access	R/W	R/W
Default	00	00

Bit Number	23:20	19:18	17:16
Bit Name	RESERVED	DPWM3_SYNC_SEL	DPWM2_SYNC_SEL
Access	-	R/W	R/W
Default	0000	00	00

Bit Number	15:14	13:12	11:9
Bit Name	DPWM1_SYNC_SEL	DPWM0_SYNC_SEL	DPWM3_FILTER_SEL
Access	R/W	R/W	R/W
Default	00	00	010

Bit Number	8:6	5:3	2:0
Bit Name	DPWM2_FILTER_SEL	DPWM1_FILTER_SEL	DPWM0_FILTER_SEL
Access	R/W	R/W	R/W
Default	010	001	000

**Bits 31-30: DPWM3\_SYNC\_FET\_SEL** – Selects Ramp source for DPWM3 PWM-B SyncFET soft on/off

- 0 = Front End 0 Ramp output selected (Default)
- 1 = Front End 1 Ramp output selected
- 2 = Front End 2 Ramp output selected

**Bits 29-28: DPWM2\_SYNC\_FET\_SEL** – Selects Ramp source for DPWM2 PWM-B SyncFET soft on/off

- 0 = Front End 0 Ramp output selected (Default)
- 1 = Front End 1 Ramp output selected
- 2 = Front End 2 Ramp output selected

**Bits 27-26: DPWM1\_SYNC\_FET\_SEL** – Selects Ramp source for DPWM1 PWM-B SyncFET soft on/off

- 0 = Front End 0 Ramp output selected (Default)
- 1 = Front End 1 Ramp output selected
- 2 = Front End 2 Ramp output selected

**Bits 25-24: DPWM0\_SYNC\_FET\_SEL** – Selects Ramp source for DPWM0 PWM-B SyncFET soft on/off

- 0 = Front End 0 Ramp output selected (Default)
- 1 = Front End 1 Ramp output selected
- 2 = Front End 2 Ramp output selected

**Bits 23-20: RESERVED** – Unused bits

**Bits 19-18: DPWM3\_SYNC\_SEL** – Selects Master Sync for DPWM 3 when DPWM 3 configured in slave mode

- 0 = DPWM 0 Sync (Default)
- 1 = DPWM 1 Sync
- 2 = DPWM 2 Sync
- 3 = DPWM 3 Sync

**Bits 17-16: DPWM2\_SYNC\_SEL** – Selects Master Sync for DPWM 2 when DPWM 2 configured in slave mode

- 0 = DPWM 0 Sync (Default)
- 1 = DPWM 1 Sync
- 2 = DPWM 2 Sync
- 3 = DPWM 3 Sync

**Bits 15-14: DPWM1\_SYNC\_SEL** – Selects Master Sync for DPWM 1 when DPWM 1 configured in slave mode

- 0 = DPWM 0 Sync (Default)
- 1 = DPWM 1 Sync
- 2 = DPWM 2 Sync
- 3 = DPWM 3 Sync

**Bits 13-12: DPWM0\_SYNC\_SEL** – Selects Master Sync for DPWM 0 when DPWM 0 configured in slave mode

- 0 = DPWM 0 Sync (Default)
- 1 = DPWM 1 Sync
- 2 = DPWM 2 Sync
- 3 = DPWM 3 Sync

**Bits 11-9: DPWM3\_FILTER\_SEL** – Selects source of duty cycle/resonant period for DPWM Module 3

- 0 = Filter 0 Output Selected (Default)
- 1 = Filter 1 Output Selected
- 2 = Filter 2 Output Selected
- 3 = Constant Power Module Selected
- 4 = DPWM\_ON\_TIME value from Light Load Control Register

**Bits 8-6: DPWM2\_FILTER\_SEL** – Selects source of duty cycle/resonant period for DPWM Module 2

- 0 = Filter 0 Output Selected (Default)
- 1 = Filter 1 Output Selected
- 2 = Filter 2 Output Selected
- 3 = Constant Power Module Selected
- 4 = DPWM\_ON\_TIME value from Light Load Control Register

**Bits 5-3: DPWM1\_FILTER\_SEL** – Selects source of duty cycle/resonant period for DPWM Module 1

- 0 = Filter 0 Output Selected (Default)
- 1 = Filter 1 Output Selected
- 2 = Filter 2 Output Selected
- 3 = Constant Power Module Selected
- 4 = DPWM\_ON\_TIME value from Light Load Control Register

**Bits 2-0: DPWM0\_FILTER\_SEL** – Selects source of duty cycle/resonant period for DPWM Module 0

- 0 = Filter 0 Output Selected (Default)
- 1 = Filter 1 Output Selected
- 2 = Filter 2 Output Selected
- 3 = Constant Power Module Selected
- 4 = DPWM\_ON\_TIME value from Light Load Control Register

### **A.1.10 Constant Power Control Register (CPCTRL)**

**Address 00020024**

Bit Number	16	15	14	13
Bit Name	CPCC_INT_EN	DAC_COMP_EN	FW_DIVISOR_EN	LOWER_COMP_EN
Access	R/W	R/W	R/W	R/W
Default	0	0	0	0

Bit Number	12	11:10	9:8	7:5	4:3
Bit Name	VLOOP_FREEZE_EN	VLOOP_SEL	CLOOP_SEL	THRESH_SEL	DIVISOR_SEL
Access	R/W	R/W	R/W	R/W	R/W
Default	0	00	00	000	00

Bit Number	2:1	0
Bit Name	CPCC_CONFIG	CPCC_EN
Access	R/W	R/W
Default	00	0

**Bit 16: CPCC\_INT\_EN** – Constant Power/Constant Current Interrupt Enable  
 0 = Interrupt disabled on mode switches (Default)  
 1 = Interrupt enabled on mode switches

**Bit 15: DAC\_COMP\_EN** – Enables comparison of DAC Setpoint and quotient of Max Power/Sense Current in Loop Switching Mode. Minimum of DAC setpoint and calculated quotient sets voltage loop setpoint in Constant Voltage and Constant Power modes  
 0 = Operating Mode controls Voltage Loop DAC Setpoint (Default)  
 1 = Minimum of DAC setpoint and calculated quotient used as Voltage Loop DAC Setpoint

**Bit 14: FW\_DIVISOR\_EN** – Enables Firmware value for divisor in Constant Power calculations  
 0 = Divisor selected by **DIVISOR\_SEL** (Bits 7:6) (Default)  
 1 = Divisor driven by Firmware Current Register

**Bit 13: LOWER\_COMP\_EN** – Enables output of lowest duty from current or voltage loop when Constant Power/Constant Current module controls loop output  
 0 = Loop output controlled by mode selection, voltage loop selected in constant voltage and constant power mode, current loop selected in constant current mode (Default)  
 1 = Loop output controlled by lowest duty from voltage or current loops

**Bit 12: VLOOP\_FREEZE\_EN** – Enables freezing of Voltage Loop Integrator when current loop selected in Loop Switching configuration  
 0 = Freezing of Voltage Loop Integrator disabled (Default)  
 1 = Freezing of Voltage Loop Integrator enabled

**Bits 11-10: VLOOP\_SEL** – Configures voltage loop for loop switching mode  
 0 = Filter 0 Output Selected (Default)  
 1 = Filter 1 Output Selected  
 2 = Filter 2 Output Selected

**Bits 9-8: CLOOP\_SEL** – Configures current loop for loop switching mode  
 0 = Filter 0 Output Selected (Default)  
 1 = Filter 1 Output Selected  
 2 = Filter 2 Output Selected

**Bits 7-5: THRESH\_SEL** – Configures input threshold selected for use in Constant Power comparison  
 0 = Filter 0 Output Selected (Default)  
 1 = Filter 1 Output Selected  
 2 = Filter 2 Output Selected  
 3 = Front End 0 Absolute Value Data Selected  
 4 = Front End 1 Absolute Value Data Selected

5 = Front End 2 Absolute Value Data Selected

**Bits 4-3: DIVISOR\_SEL** – Configures value used for divisor in Constant Power calculations

0 = Front End 0 Absolute Value Data Selected (Default)

1 = Front End 1 Absolute Value Data Selected

2 = Front End 2 Absolute Value Data Selected

**Bit 2-1: CPCC\_CONFIG** – Controls Constant Power/Constant Current module configuration

00 = Average Current Mode (Default)

01 = Constant Power Module controls selection of voltage/current loop

10 = Front End Switching Mode

11 = Reserved

**Bit 0: CPCC\_EN** – Constant Power Constant/Current Module Enable

0 = Constant Power/Constant Current Module disabled (Default)

1 = Constant Power/Constant Current Module enabled

### A.1.11 Constant Power Nominal Threshold Register (CPNOM)

Address 00020028

Bit Number	25:16	15:10	9:0
Bit Name	NOM_CURRENT_UPPER	RESERVED	NOM_CURRENT_LOWER
Access	R/W	-	R/W
Default	00_0000_0000	00_0000	00_0000_0000

**Bits 25-16: NOM\_CURRENT\_UPPER** – Configures  $I_{NOM}$  value used in Constant Power/Constant Current Calculations, when sensed value exceeds NOM\_CURRENT\_UPPER in Constant Voltage mode, setpoint will switch to Constant Power mode

**Bits 15-10: RESERVED** – Unused Bits

**Bits 9-0: NOM\_CURRENT\_LOWER** – Configures  $I_{NOM}$  value used in Constant Power/Constant Current Calculations, when sensed value falls below NOM\_CURRENT\_LOWER in Constant Power mode, setpoint will switch to Constant Voltage mode

### A.1.12 Constant Power Max Threshold Register (CPMAX)

Address 0002002C

Bit Number	25:16	15:10	9:0
Bit Name	MAX_CURRENT_UPPER	RESERVED	MAX_CURRENT_LOWER
Access	R/W	-	R/W
Default	00_0000_0000	00_0000	00_0000_0000

**Bits 25-16: MAX\_CURRENT\_UPPER** – Configures  $I_{MAX}$  value used in Constant Power/Constant Current Calculations, when sensed value exceeds MAX\_CURRENT\_UPPER in Constant Power mode, setpoint will switch to Max Current mode

**Bits 15-10: RESERVED** – Unused Bits

**Bits 9-0: MAX\_CURRENT\_LOWER** – Configures  $I_{MAX}$  value used in Constant Power/Constant Current Calculations, when sensed value falls below MAX\_CURRENT\_LOWER in Max Current mode, setpoint will switch to Constant Power mode

### A.1.13 Constant Power Configuration Register (CPCONFIG)

Address 00020030

Bit Number	25:16	15:10	9:0
Bit Name	MAX_CURRENT	RESERVED	NOM_VOLTAGE
Access	R/W	-	R/W
Default	00_0000_0000	00_0000	00_0000_0000

**Bits 25-16: MAX\_CURRENT** – Configures  $I_{MAX}$  setpoint used in Constant Power/Constant Current Calculations in Max Current mode

**Bits 15-10: RESERVED** – Unused Bits

**Bits 9-0: NOM\_VOLTAGE** – Configures  $V_{NOM}$  setpoint used in Constant Power/Constant Current Calculations in Constant Voltage mode (Loop Oring configuration selected)

#### A.1.14 Constant Power Max Power Register (CPMAXPWR)

Address 00020034

<b>Bit Number</b>	<b>19:0</b>
<b>Bit Name</b>	MAX_POWER
<b>Access</b>	R/W
<b>Default</b>	0000_0000_0000_0000_0000

**Bits 19-0: MAX\_POWER** – Configures  $P_{MAX}$  value used in Constant Power/Constant Current calculations in Constant Power mode

#### A.1.15 Constant Power Integrator Threshold Register (CPINTTHRESH)

Address 00020038

<b>Bit Number</b>	<b>23:0</b>
<b>Bit Name</b>	INT_THRESH
<b>Access</b>	R/W
<b>Default</b>	0000_0000_0000_0000_0000

**Bits 23-0: INT\_THRESH** – 24-bit signed value added to Current Loop Duty value to determine when to freeze Current Loop Integrator

#### A.1.16 Constant Power Firmware Divisor Register (CPFWDIVISOR)

Address 0002003C

<b>Bit Number</b>	<b>9:0</b>
<b>Bit Name</b>	FW_DIVISOR
<b>Access</b>	R/W
<b>Default</b>	00_0000_0000

**Bits 9-0: FW\_DIVISOR**– 10-bit value used in Constant Power calculation when firmware value is selected in Bit 17 of Constant Power Control Register

### A.1.17 Constant Power Status Register (CPSTAT)

Address 00020040

Bit Number	8	7	6
Bit Name	CONSTANT_CUR	CONSTANT_PWR	CONSTANT_VOLT
Access	R	R	R
Default	-	-	-

Bit Number	5	4	3
Bit Name	CC_TO_CV_INT	CV_TO_CC_INT	CC_TO_CP_INT
Access	R	R	R
Default	-	-	-

Bit Number	2	1	0
Bit Name	CP_TO_CC_INT	CP_TO_CV_INT	CV_TO_CP_INT
Access	R	R	R
Default	-	-	-

**Bit 8: CONSTANT\_CUR** – Constant Current Mode Indication

0 = Constant Current Mode not enabled

1 = Constant Current Mode enabled

**Bit 7: CONSTANT\_PWR** – Constant Power Mode Indication

0 = Constant Power Mode not enabled

1 = Constant Power Mode enabled

**Bit 6: CONSTANT\_VOLT** – Constant Voltage Mode Indication

0 = Constant Voltage Mode not enabled

1 = Constant Voltage Mode enabled

**Bit 5: CC\_TO\_CV\_INT** – Constant Current Mode to Constant Voltage Mode latched status, cleared on read

0 = No transition from Constant Current to Constant Voltage detected

1 = Transition from Constant Current to Constant Voltage detected

**Bit 4: CV\_TO\_CC\_INT** – Constant Voltage Mode to Constant Current Mode latched status, cleared on read

0 = No transition from Constant Voltage to Constant Current detected

1 = Transition from Constant Voltage to Constant Current detected

**Bit 3: CC\_TO\_CP\_INT** – Constant Current Mode to Constant Power Mode latched status, cleared on read

0 = No transition from Constant Current to Constant Power detected

1 = Transition from Constant Current to Constant Power detected

**Bit 2: CP\_TO\_CC\_INT** – Constant Power Mode to Constant Current Mode latched status, cleared on read

0 = No transition from Constant Power to Constant Current detected

1 = Transition from Constant Power to Constant Current detected

**Bit 1: CP\_TO\_CV\_INT** – Constant Power Mode to Constant Voltage Mode latched status, cleared on read

0 = No transition from Constant Power to Constant Voltage detected

1 = Transition from Constant Power to Constant Voltage detected

**Bit 0: CV\_TO\_CP\_INT** – Constant Voltage Mode to Constant Power Mode latched status, cleared on read

0 = No transition from Constant Voltage to Constant Power detected

1 = Transition from Constant Voltage to Constant Power detected



**A.1.18 Cycle Adjustment Control Register (CYCADJCTRL)**

Address 00020044

Bit Number	9:7	6:5
Bit Name	CYC_ADJ_GAIN	CYC_ADJ_SYNC
Access	R/W	R/W
Default	000	00

Bit Number	4:3	2:1	0
Bit Name	SECOND_SAMPLE_SEL	FIRST_SAMPLE_SEL	CYC_ADJ_EN
Access	R/W	R/W	R/W
Default	00	00	0

**Bits 9-7: CYC\_ADJ\_GAIN** – Configures gain of Cycle Adjustment calculation

- 0 = 1x gain (Default)
- 1 = 2x gain
- 2 = 4x gain
- 3 = 8x gain
- 4 = 16x gain
- 5 = 32x gain
- 6 = 64x gain
- 7 = 128x gain

**Bits 6-5: CYC\_ADJ\_SYNC** – Selects which DPWM A trigger synchronizes cycle adjustment calculation, first 2 samples after receipt of DPWM A trigger will be used for Cycle Adjustment Calculation.

- 0 = DPWM-1A trigger selected (Default)
- 1 = DPWM-2A trigger selected
- 2 = DPWM-3A trigger selected
- 3 = DPWM-4A trigger selected

**Bits 4-3: SECOND\_SAMPLE\_SEL** – Configures Front End Module Data used for Second Sample of Cycle Adjustment Calculation

- 0 = Front End Module 0 Error Data selected (Default)
- 1 = Front End Module 1 Error Data selected
- 2 = Front End Module 2 Error Data selected

**Bits 2-1: FIRST\_SAMPLE\_SEL** – Configures Front End Module Data used for First Sample of Cycle Adjustment Calculation

- 0 = Front End Module 0 Error Data selected (Default)
- 1 = Front End Module 1 Error Data selected
- 2 = Front End Module 2 Error Data selected

**Bit 0: CYC\_ADJ\_EN** – Cycle Adjustment Calculation Enable

- 0 = Cycle Adjustment Calculation disabled (Default)
- 1 = Cycle Adjustment Calculation enabled

**A.1.19 Cycle Adjustment Limit Register (CYCADJLIM)**

Address 00020048

Bit Number	28:16	15:13	12:0
Bit Name	CYC_ADJ_UPPER_LIMIT	RESERVED	CYC_ADJ_LOWER_LIM
Access	R/W	-	R/W
Default	0_0000_0000_0000	000	0_0000_0000_0000

**Bits 28-16: CYC\_ADJ\_UPPER\_LIMIT** – Cycle Adjustment Calculation signed upper limit value, output of Cycle Adjustment Calculation is clamped at the upper limit, if calculated result exceeds the upper limit. LSB resolution equals High Frequency Oscillator period/16.

**Bits 15-13: RESERVED** – Unused Bits

**Bits 12-0: CYC\_ADJ\_LOWER\_LIMT** – Cycle Adjustment Calculation signed lower limit value, output of Cycle Adjustment Calculation is clamped at the lower limit, if calculated result falls below the lower limit. LSB resolution equals High Frequency Oscillator period/16.

### A.1.20 Cycle Adjustment Status Register (CYCADJSTAT)

Address 0002004C

Bit Number	28:16	15:10	9:0
Bit Name	CYC_ADJ_CALC	RESERVED	CYC_ADJ_ERROR
Access	R	-	R
Default	-	00_0000	-

**Bits 28-16: CYC\_ADJ\_CALC** – 13-bit signed value representing calculated Cycle Adjustment provided to DPWM module based on first 2 error samples

**Bits 15-10: RESERVED** – Unused Bits

**Bits 9-0: CYC\_ADJ\_ERROR** – 10-bit signed value representing calculated error of the first 2 error samples received

### A.1.21 Global Enable Register (GLBEN)

Address 00020050

Bit Number	10	9	8	7:4
Bit Name	FE_CTRL2_EN	FE_CTRL1_EN	FE_CTRL0_EN	RESERVED
Access	R/W	R/W	R/W	-
Default	0	0	0	0000

Bit Number	3	2	1	0
Bit Name	DPWM3_EN	DPWM2_EN	DPWM1_EN	DPWM0_EN
Access	R/W	R/W	R/W	R/W
Default	0	0	0	0

**Bit 10: FE\_CTRL2\_EN** – Global Firmware Enable for Front End Control 2 Module

0 = Front End Control 2 Module Disabled (Default)

1 = Front End Control 2 Module Enabled

**Bit 9: FE\_CTRL1\_EN** – Global Firmware Enable for Front End Control 1 Module

0 = Front End Control 1 Module Disabled (Default)

1 = Front End Control 1 Module Enabled

**Bit 8: FE\_CTRL0\_EN** – Global Firmware Enable for Front End Control 0 Module

0 = Front End Control 0 Module Disabled (Default)

1 = Front End Control 0 Module Enabled

**Bits 7-4: RESERVED** – Unused Bits

**Bit 3: DPWM3\_EN** – Global Firmware Enable for DPWM 3 Module

0 = DPWM 3 Module Disabled (Default)

1 = DPWM 3 Module Enabled

**Bit 2: DPWM2\_EN** – Global Firmware Enable for DPWM 2 Module

0 = DPWM 2 Module Disabled (Default)

1 = DPWM 2 Module Enabled

**Bit 1: DPWM1\_EN** – Global Firmware Enable for DPWM 1 Module

0 = DPWM 1 Module Disabled (Default)

1 = DPWM 1 Module Enabled

**Bit 0: DPWM0\_EN** – Global Firmware Enable for DPWM 0 Module

0 = DPWM 0 Module Disabled (Default)

1 = DPWM 0 Module Enabled

### A.1.22 PWM Global Period Register (PWMGLBPRD)

Address 00020054

Bit Number	17:4	3:0
Bit Name	PRD	RESERVED
Access	R/W	-
Default	00_0000_0000_0000	0000

**Bits 17-4: PRD** – Global PWM Period value, overriding DPWM Period settings when global PWM period is selected within each DPWM module

**Bits 3-0: RESERVED** – Unused Bits

### A.1.23 Sync Control Register (SYNCCTRL)

Address 00020058

Bit Number	5	4:2	1	0
Bit Name	SYNC_IN	SYNC_MUX_SEL	SYNC_OUT	SYNC_DIR
Access	R	R/W	R/W	R/W
Default	-	000	1	1

**Bit 5: SYNC\_IN** – Value of Sync pin

0 = Logic level low present on Sync pin

1 = Logic level high present on Sync pin

**Bits 4-2: SYNC\_MUX\_SEL** – Selects which module controls Sync pin output

000 = DPWM 0 Sync Output (Default)

001 = DPWM 1 Sync Output

010 = DPWM 2 Sync Output

011 = DPWM 3 Sync Output

100 = Value from SYNC\_OUT (Bit 1)

101 = Value from CLKOUT signal in TSAR Module (See Section 15.1)

110 = Low-Frequency Oscillator Clock Output

111 = Driven low

**Bit 1: SYNC\_OUT** – Configure output value for Sync pin, if used as an output

0 = Sync pin driven low in output mode

1 = Sync pin driven high in output mode (Default)

**Bit 0: SYNC\_DIR** – Configure direction of Sync pin

0 = Sync pin configured as an output pin

1 = Sync pin configured as an input pin (Default)

### A.1.24 Light Load Control Register (LLCTRL)

Address 0002005C

Bit Number	25:8	7:4	3	2:1	0
Bit Name	DPWM_ON_TIME	RESERVED	CYCLE_CNT_EN	LL_FILTER_SEL	LL_EN
Access	R/W	-	R/W	R/W	R/W
Default	00_0000_0000_0000_0000	0000	0	00	0

**Bits 25-8: DPWM\_ON\_TIME** – DPWM pulse width used for EADC-based light load mode operation, when selected Filter data exceeds TURN\_ON\_THRESH value

**Bits 7-3: RESERVED** – Unused Bits

**Bit 3: CYCLE\_CNT\_EN** – Enables Switching Cycle Counter for enabling constant pulse widths when configured in Light Load operation

0 = Switching Cycle Counter disabled (Default)

1 = Switching Cycle Counter enabled

**Bits 2-1: LL\_FILTER\_SEL** – Configures source of filter data for Light Load comparisons

0 = Filter 0 data selected (Default)

1 = Filter 1 data selected

2 = Filter 2 data selected

**Bit 0: LL\_EN** –Light Load Mode Enable

0 = Mode disabled (Default)

1 = Mode enabled

### A.1.25 Light Load Enable Threshold Register (LLENTHRESH)

Address 00020060

Bit Number	31:24	23:18	17:0
Bit Name	CYCLE_CNT_THRESH	RESERVED	TURN_ON_THRESH
Access	R/W	-	R/W
Default	0000_0000	0000_00	00_0000_0000_0000_0000

**Bits 31-24: CYCLE\_CNT\_THRESH** – Switching Cycle threshold where constant width DPWM pulses are enabled when number of switching cycles without pulses exceeds threshold

**Bits 23-18: RESERVED** – Unused Bits

**Bits 17-0: TURN\_ON\_THRESH** – Filter data threshold where constant width DPWM pulses are enabled when filter data exceeds threshold

### A.1.26 Light Load Disable Threshold Register (LLDISTHRESH)

Address 00020064

Bit Number	17:0
Bit Name	TURN_OFF_THRESH
Access	R/W
Default	00_0000_0000_0000_0000

**Bits 17-0: TURN\_OFF\_THRESH** – Filter data threshold where constant width DPWM pulses are disabled when filter data falls below threshold

### A.1.27 Analog Peak Current Mode Ramp Register (APCMRAMP)

Address 00020068

Bit Number	5:4	3:0
Bit Name	PCM_FILTER_SEL	RESERVED
Access	R/W	R
Default	00	00

**Bits 5-4: PCM\_FILTER\_SEL** – Selects source of Peak Current Slope Compensation Ramp Start  
 0 = Filter 0 data selected (Default)  
 1 = Filter 1 data selected  
 2 = Filter 2 data selected  
 3 = Constant Power/Constant Current data selected

**Bits 3-0: Reserved**

### A.1.28 Analog Peak Current Mode Control Register (APCMCTRL)

Address 00020070

Bit Number	3	2:1	0
Bit Name	PCM_LATCH_EN	PCM_FE_SEL	PCM_EN
Access	R/W	R/W	R/W
Default	0	00	0

**Bit 3: PCM\_LATCH\_EN** – Enables latching of Peak Current Flag to end of frame  
 0 = PCM Flag is not latched to end of PCM Frame (Default)  
 1 = PCM Flag is latched to end of PCM Frame

**Bits 2-1: PCM\_FE\_SEL** – Selects source of Front End Comparator output for Analog Peak Current Mode Control

0 = Front End Control 0 Comparator output selected (Default)  
 1 = Front End Control 1 Comparator output selected  
 2 = Front End Control 2 Comparator output selected

**Bit 0: PCM\_EN** – Analog Peak Current Mode Control Module Enable  
 0 = Analog Peak Current Mode Control Module disabled (Default)  
 1 = Analog Peak Current Mode Control Module enabled

### A.1.29 DTC Control (DTCCTRL)

Address 0020078

<b>Bit Number</b>	<b>22</b>	<b>21:20</b>	<b>19:17</b>
<b>Bit Name</b>	FLT_INT_EN	FLT_MAX	FLT_STEP
<b>Access</b>	R/W	R/W	R/W
<b>Default</b>	0	0	0

<b>Bit Number</b>	<b>16:13</b>	<b>12:9</b>	<b>8:5</b>	<b>4</b>
<b>Bit Name</b>	FLT_THRESH	PWM_A_SEL	PWM_B_SEL	A_POL
<b>Access</b>	R/W	R/W	R/W	R/W
<b>Default</b>	0	0	0	0

<b>Bit Number</b>	<b>3</b>	<b>2</b>	<b>1</b>	<b>0</b>
<b>Bit Name</b>	B_POL	INPUT_MODE	MODE	DTC_EN
<b>Access</b>	R/W	R/W	R/W	R/W
<b>Default</b>	0	0	0	0

**Bit 22: FLT\_INT\_EN**– Enables interrupt generation when a fault flag condition has been met  
 0 = Interrupt disabled (default)  
 1 = Interrupt enabled

**Bit 21:20: FLT\_MAX**– Sets the number of consecutive detected faults before a fault step is utilized  
 0 = 1 (default)  
 1 = 2  
 2 = 4  
 3 = 8

**Bit 19:17: FLT\_STEP**– Sets the negative step size when a fault condition is detected that exceeds the fault max value. If the fault\_max condition has not been met the step size is -1. Step size is in HFO clock increments.  
 0 = -1 (default)  
 1 = -5  
 2 = -10  
 3 = -25  
 4 = -50  
 5 = -75  
 6 = -100  
 7 = -125

**Bit 16-13: FLT\_THRESH**– Sets the measurement threshold for a fault condition to initiate a fault step. Threshold is in HFO clock increments.

**Bit 12-9 PWM\_A\_SEL** – Selects the phase A negative edge reference to begin a measurement window  
 0 = Disabled (Default)  
 1 = DPWM-0-A  
 2 = DPWM-1-A  
 3 = DPWM-2-A  
 4 = DPWM-3-A  
 5 = DPWM-0-B  
 6 = DPWM-1-B

7 = DPWM-2-B

8 = DPWM-3-B

**Bit 8-5: PWM\_B\_SEL** – Selects the phase B negative edge reference to begin a measurement window

0 = Disabled (Default)

1 = DPWM-0-A

2 = DPWM-1-A

3 = DPWM-2-A

4 = DPWM-3-A

5 = DPWM-0-B

6 = DPWM-1-B

7 = DPWM-2-B

8 = DPWM-3-B

**Bit 4: A\_POL** – Sets the signal polarity of the DTC input to the device

0 = Active Low (Default)

1 = Active High

**Bit 3: B\_POL** – Sets the signal polarity of the DTC input to the device

0 = Active Low (Default)

1 = Active High

**Bit 2: INPUT\_MODE** – Sets the input method for the DTC module

0 = Phase A and Phase B input signals occur on separate inputs (Default)

1 = Phase A and Phase B input signals occur on the same input

**Bit 1: MODE** – Sets mode control of the DTC phase accumulator values

0 = Automatic Mode. Accumulators A and B are changed by hardware and stay within limits programmed in the DTCLIMIT register. (Default)

1 = Manual Mode. Accumulator A and B set by programmed values in the DTCMANUAL register.

**Bit 0: DTC\_EN** – DTC Enable

0 = Dead-time Compensate Module disabled (Default)

1 = Dead-time Compensate Module enabled

### A.1.30 DTC Target (DTCTARGET)

Address 002007C

Bit Number	23:17	16:9	8:7	6:0
Bit Name	DETECT_BLANK	DETECT_LEN	TARGET_OFFSET	TARGET_LOW
Access	R/W	R/W	R/W	R/W
Default	000_0000	0000_0000	00	000_0000

**Bit 23-17: DETECT\_BLANK**– Sets the target measurement window blanking length, in HFO clock increments.

**Bit 16-9: DETECT\_LEN**– Sets the target measurement window length, in HFO clock increments.

**Bit 8-7: TARGET\_OFFSET**– Target Threshold Offset. Target upper threshold = target low + target offset

0 = 0 (Default)

1 = 2 HFO clocks

2 = 4 HFO clocks

3 = 8 HFO clocks

**Bit 6-0: TARGET\_LOW** – Target Lower Threshold, in HFO clock increments



**A.1.31 DTC Auto Control Limit (DTCLIMIT)**
**Address 0020080**

Bit Number	19:10	9:0
Bit Name	ADJ_MAX	ADJ_MIN
Access	R/W	R/W
Default	01_1111_1111	10_0000_0000

**Bit 19-10: ADJ\_MAX** – Sets the signed integer upper clamp for the accumulators. The integer range is (-512 to 511)

**Bit 9-0: ADJ\_MIN** – Sets the signed integer lower clamp for the accumulators. The integer range is (-512 to 511)

**A.1.32 DTC Manual Control (DTCMANUAL)**
**Address 0020084**

Bit Number	19:10	9:0
Bit Name	A_ADJ	B_ADJ
Access	R/W	R/W
Default	00_0000_0000	00_0000_0000

Register is ignored in automatic mode.

**Bit 19-10: A\_ADJ** – Sets the signed A accumulator value when manual control is enabled.

**Bit 9-0: B\_ADJ** Sets the signed B accumulator value when manual control is enabled.

**A.1.33 DTC Monitor (DTCMONITOR)**
**Address 0020088**

Bit Number	19:10	9:0
Bit Name	A_ADJ	B_ADJ
Access	R	R
Default	0_0000_0000	0_0000_0000

**Bit 19-10: A\_ADJ** – Monitored accumulator A value from the DTC module

**Bit 9-0: B\_ADJ** - Monitored accumulator B value from the DTC module

**A.1.34 DTC Status (DTCSTAT)**
**Address 002008C**

Bit Number	14:8	7:1	0
Bit Name	A_CNT	B_CNT	FLAG
Access	R	R	R
Default	000_0000	000_0000	0

**Bit 14-8: A\_CNT** – Last measurement value for phase A input signal

**Bit 7-1: B\_CNT** – Last measurement value for phase B input signal

**Bit 0: FLAG** – Flag is set when the fault count exceeds the FLT MAX value programmed in the DTCCTRL register.

## A.2 Fault Mux Registers

### A.2.1 Analog Comparator Control 0 Register (ACOMPCTRL0)

Address 00030000

Bit Number	30:24	23:22	21:19	18
Bit Name	ACOMP_B_THRESH	RESERVED	ACOMP_B_SEL	ACOMP_B_POL
Access	R/W	-	R/W	R/W
Default	000_0000	00	000	1

Bit Number	17	16:15	14:8	7:6
Bit Name	ACOMP_B_INT_EN	RESERVED	ACOMP_A_THRESH	RESERVED
Access	R/W	-	R/W	-
Default	0	00	000_0000	00

Bit Number	5:3	2	1	0
Bit Name	ACOMP_A_SEL	ACOMP_A_POL	ACOMP_A_INT_EN	ACOMP_EN
Access	R/W	R/W	R/W	R/W
Default	000	1	0	0

**Bits 30-24: ACOMP\_B\_THRESH** – Configures Analog Comparator B Threshold value

0 = Comparator Reference of 19.53125 mV (Default)

1 = Comparator Reference of 39.0625 mV

.....

127 = Comparator Reference of 2.5 V

**Bits 23-22: RESERVED** – Unused bits

**Bits 21-19: ACOMP\_B\_SEL** – Configures Analog Comparator B Threshold

0 = Analog Comparator B Threshold set by ACOMP\_B\_THRESH (Default)

1 = Analog Comparator B Threshold set by Comparator Ramp 0

2 = Analog Comparator B Threshold set by Filter 0 Output

3 = Analog Comparator B Threshold set by Filter 1 Output

4 = Analog Comparator B Threshold set by Filter 2 Output

**Bit 18: ACOMP\_B\_POL** – Analog Comparator B Polarity

0 = Comparator result enabled when input falls below threshold

1 = Comparator result enabled when input exceeds threshold (Default)

**Bit 17: ACOMP\_B\_INT\_EN** – Analog Comparator B Interrupt Enable

0 = Disables Analog Comparator B Interrupt generation (Default)

1 = Enables Analog Comparator B Interrupt generation

**Bits 16-15: RESERVED** – Unused bits

**Bits 14-8: ACOMP\_A\_THRESH** – Configures Analog Comparator A Threshold

0 = Comparator Reference of 19.53125 mV (Default)

1 = Comparator Reference of 39.0625 mV

.....

127 = Comparator Reference of 2.5 V

**Bits 7-6: RESERVED** – Unused bits

**Bits 5-3: ACOMP\_A\_SEL** – Configures Analog Comparator A Threshold

0 = Analog Comparator A Threshold set by ACOMP\_A\_THRESH (Default)

1 = Analog Comparator A Threshold set by Comparator Ramp 0

2 = Analog Comparator A Threshold set by Filter 0 Output

3 = Analog Comparator A Threshold set by Filter 1 Output

4 = Analog Comparator A Threshold set by Filter 2 Output

**Bit 2: ACOMP\_A\_POL** – Analog Comparator A Polarity

0 = Comparator result enabled when input falls below threshold

1 = Comparator result enabled when input exceeds threshold (Default)

**Bit 1: ACOMP\_A\_INT\_EN** – Analog Comparator A Interrupt Enable

0 = Disables Analog Comparator A Interrupt generation (Default)

1 = Enables Analog Comparator A Interrupt generation

**Bit 0: ACOMP\_EN** – Analog Comparators Enable

0 = Analog Comparators Disabled (Default)

1 = Analog Comparators Enabled

### A.2.2 Analog Comparator Control 1 Register (ACOMPCTRL1)

Address 00030004

Bit Number	30:24	23:22	21:19	18
Bit Name	ACOMP_D_THRESH	RESERVED	ACOMP_D_SEL	ACOMP_D_POL
Access	R/W	-	R/W	R/W
Default	000_0000	00	000	1

Bit Number	17	16	15	14:8
Bit Name	ACOMP_D_INT_EN	ACOMP_D_OUT_EN	RESERVED	ACOMP_C_THRESH
Access	R/W	R/W	-	R/W
Default	0	0	0	000_0000

Bit Number	7:6	5:3	2	1	0
Bit Name	RESERVED	ACOMP_C_SEL	ACOMP_C_POL	ACOMP_C_INT_EN	RESERVED
Access	-	R/W	R/W	R/W	-
Default	00	000	1	0	0

**Bits 30-24: ACOMP\_D\_THRESH** – Configures Analog Comparator D Threshold

0 = Comparator Reference of 19.53125 mV (Default)

1 = Comparator Reference of 39.0625 mV

.....

127 = Comparator Reference of 2.5 V

**Bits 23-22: RESERVED** – Unused bits

**Bits 21-19: ACOMP\_D\_SEL** – Configures Analog Comparator D Threshold

0 = Analog Comparator D Threshold set by ACOMP\_D\_THRESH (Default)

1 = Analog Comparator D Threshold set by Comparator Ramp 0

2 = Analog Comparator D Threshold set by Filter 0 Output

3 = Analog Comparator D Threshold set by Filter 1 Output

4 = Analog Comparator D Threshold set by Filter 2 Output

**Bit 18: ACOMP\_D\_POL** – Analog Comparator D Polarity

0 = Comparator result enabled when input falls below threshold

1 = Comparator result enabled when input exceeds threshold (Default)

**Bit 17: ACOMP\_D\_INT\_EN** – Analog Comparator D Interrupt Enable

0 = Disables Analog Comparator D Interrupt generation (Default)

1 = Enables Analog Comparator D Interrupt generation

**Bit 16: ACOMP\_D\_OUT\_EN** – Analog Comparator D DAC Output Enable

0 = Disables output of Comparator DAC D onto AD pin (Default)

1 = Enables output of Comparator DAC D onto AD pin

**Bit 15: RESERVED** – Unused bit

**Bits 14-8: ACOMP\_C\_THRESH** – Configures Analog Comparator C Threshold

0 = Comparator Reference of 19.53125 mV (Default)

1 = Comparator Reference of 39.0625 mV

.....

127 = Comparator Reference of 2.5 V

**Bits 7-6: RESERVED** – Unused bits

**Bits 5-3: ACOMP\_C\_SEL** – Configures Analog Comparator C Threshold

0 = Analog Comparator C Threshold set by ACOMP\_C\_THRESH (Default)

1 = Analog Comparator C Threshold set by Comparator Ramp 0

2 = Analog Comparator C Threshold set by Filter 0 Output

3 = Analog Comparator C Threshold set by Filter 1 Output

4 = Analog Comparator C Threshold set by Filter 2 Output

**Bit 2: ACOMP\_C\_POL** – Analog Comparator C Polarity

0 = Comparator result enabled when input falls below threshold

1 = Comparator result enabled when input exceeds threshold (Default)

**Bit 1: ACOMP\_C\_INT\_EN** – Analog Comparator C Interrupt Enable

0 = Disables Analog Comparator C Interrupt generation (Default)

1 = Enables Analog Comparator C Interrupt generation

**Bit 0: RESERVED** – Unused bit

### A.2.3 Analog Comparator Control 2 Register (ACOMPCTRL2)

Address 00030008

Bit Number	30:24	23	22	21:19
Bit Name	ACOMP_F_THRESH	RESERVED	ACOMP_F_REF_SEL	ACOMP_F_SEL
Access	R/W	-	R/W	R/W
Default	000_0000	0	0	000

Bit Number	18	17	16	15
Bit Name	ACOMP_F_POL	ACOMP_F_INT_EN	ACOMP_F_OUT_EN	RESERVED
Access	R/W	R/W	R/W	-
Default	1	0	0	0

Bit Number	14:8	7:6	5:3
Bit Name	ACOMP_E_THRESH	RESERVED	ACOMP_E_SEL
Access	R/W	-	R/W
Default	000_0000	00	000

Bit Number	2	1	0
Bit Name	ACOMP_E_POL	ACOMP_E_INT_EN	ACOMP_E_OUT_EN
Access	R/W	R/W	R/W
Default	1	0	0

**Bits 30-24: ACOMP\_F\_THRESH** – Configures Analog Comparator F Threshold

0 = Comparator Reference of 19.53125 mV (Default)

1 = Comparator Reference of 39.0625 mV

.....

127 = Comparator Reference of 2.5 V

**Bit 23: RESERVED** – Unused bit

**Bit 22: ACOMP\_F\_REF\_SEL** – Analog Comparator F Reference Select

0 = Selects internal DAC reference (Default)

1 = Selects reference driven from AD-07 pin

**Bits 21-19: ACOMP\_F\_SEL** – Configures Analog Comparator F Threshold

0 = Analog Comparator F Threshold set by ACOMP\_F\_THRESH (Default)

1 = Analog Comparator F Threshold set by Comparator Ramp 0

2 = Analog Comparator F Threshold set by Filter 0 Output

3 = Analog Comparator F Threshold set by Filter 1 Output

4 = Analog Comparator F Threshold set by Filter 2 Output

**Bit 18: ACOMP\_F\_POL** – Analog Comparator F Polarity

0 = Comparator result enabled when input falls below threshold

1 = Comparator result enabled when input exceeds threshold (Default)

**Bit 17: ACOMP\_F\_INT\_EN** – Analog Comparator F Interrupt Enable

0 = Disables Analog Comparator F Interrupt generation (Default)

1 = Enables Analog Comparator F Interrupt generation

**Bit 16: ACOMP\_F\_OUT\_EN** – Analog Comparator F DAC Output Enable

0 = Disables output of Comparator DAC F onto AD pin (Default)

1 = Enables output of Comparator DAC F onto AD pin

**Bit 15: RESERVED** – Unused bit

**Bits 14-8: ACOMP\_E\_THRESH** – Configures Analog Comparator E Threshold

0 = Comparator Reference of 19.53125 mV (Default)

1 = Comparator Reference of 39.0625 mV

.....

127 = Comparator Reference of 2.5 V

**Bits 7-6: RESERVED** – Unused bits

**Bits 5-3: ACOMP\_E\_SEL** – Configures Analog Comparator E Threshold

0 = Analog Comparator E Threshold set by ACOMP\_E\_THRESH (Default)

1 = Analog Comparator E Threshold set by Comparator Ramp 0

2 = Analog Comparator E Threshold set by Filter 0 Output

3 = Analog Comparator E Threshold set by Filter 1 Output

4 = Analog Comparator E Threshold set by Filter 2 Output

**Bit 2: ACOMP\_E\_POL** – Analog Comparator E Polarity

0 = Comparator result enabled when input falls below threshold

1 = Comparator result enabled when input exceeds threshold (Default)

**Bit 1: ACOMP\_E\_INT\_EN** – Analog Comparator E Interrupt Enable

0 = Disables Analog Comparator E Interrupt generation (Default)

1 = Enables Analog Comparator E Interrupt generation

**Bit 0: ACOMP\_E\_OUT\_EN** – Analog Comparator E DAC Output Enable

0 = Disables output of Comparator DAC E onto AD pin (Default)

1 = Enables output of Comparator DAC E onto AD pin

#### A.2.4 Analog Comparator Control 3 Register (ACOMPCTRL3)

Address 0003000C

Bit Number	14:8	7:6	5:3
Bit Name	ACOMP_G_THRESH	RESERVED	ACOMP_G_SEL
Access	R/W	-	R/W
Default	000_0000	00	000

Bit Number	2	1	0
Bit Name	ACOMP_G_POL	ACOMP_G_INT_EN	ACOMP_G_OUT_EN
Access	R/W	R/W	R/W
Default	1	0	0

**Bits 14-8: ACOMP\_G\_THRESH** – Configures Analog Comparator G Threshold

0 = Comparator Reference of 19.53125 mV (Default)

1 = Comparator Reference of 39.0625 mV

.....

127 = Comparator Reference of 2.5 V

**Bits 7-6: RESERVED** – Unused bits

**Bits 5-3: ACOMP\_G\_SEL** – Configures Analog Comparator G Threshold

0 = Analog Comparator G Threshold set by ACOMP\_G\_THRESH (Default)

1 = Analog Comparator G Threshold set by Comparator Ramp 0

2 = Analog Comparator G Threshold set by Filter 0 Output

3 = Analog Comparator G Threshold set by Filter 1 Output

4 = Analog Comparator G Threshold set by Filter 2 Output

**Bit 2: ACOMP\_G\_POL** – Analog Comparator G Polarity

0 = Comparator result enabled when input falls below threshold

1 = Comparator result enabled when input exceeds threshold (Default)

**Bit 1: ACOMP\_G\_INT\_EN** – Analog Comparator G Interrupt Enable

0 = Disables Analog Comparator G Interrupt generation (Default)

1 = Enables Analog Comparator G Interrupt generation

**Bit 0: ACOMP\_G\_OUT\_EN** – Analog Comparator G DAC Output Enable

0 = Disables output of Comparator DAC G onto AD pin (Default)

1 = Enables output of Comparator DAC G onto AD pin

### A.2.5 External Fault Control Register (EXTFAULTCTRL)

Address 00030010

Bit Number	11	10	9	8
Bit Name	FAULT3_POL	FAULT2_POL	FAULT1_POL	FAULT0_POL
Access	R/W	R/W	R/W	R/W
Default	1	1	1	1

Bit Number	7	6	5	4
Bit Name	FAULT3_INT_EN	FAULT2_INT_EN	FAULT1_INT_EN	FAULT0_INT_EN
Access	R/W	R/W	R/W	R/W
Default	0	0	0	0

Bit Number	3	2	1	0
Bit Name	FAULT3_DET_EN	FAULT2_DET_EN	FAULT1_DET_EN	FAULT0_DET_EN
Access	R/W	R/W	R/W	R/W
Default	0	0	0	0

**Bit 11: FAULT3\_POL** – Polarity configuration for FAULT[3] pin

0 = Fault detection enabled on falling edge

1 = Fault detection enabled on rising edge (Default)

**Bit 10: FAULT2\_POL** – Polarity configuration for FAULT[2] pin

0 = Fault detection enabled on falling edge

1 = Fault detection enabled on rising edge (Default)

**Bit 9: FAULT1\_POL** – Polarity configuration for FAULT[1] pin

0 = Fault detection enabled on falling edge

1 = Fault detection enabled on rising edge (Default)

**Bit 8: FAULT0\_POL** – Polarity configuration for FAULT[0] pin

0 = Fault detection enabled on falling edge

1 = Fault detection enabled on rising edge (Default)

**Bit 7: FAULT3\_INT\_EN** – FAULT[3] Pin Interrupt Enable

0 = Disables Fault Detection Interrupt generation (Default)

1 = Enables Fault Detection Interrupt generation

**Bit 6: FAULT2\_INT\_EN** – FAULT[2] Pin Interrupt Enable

0 = Disables Fault Detection Interrupt generation (Default)

1 = Enables Fault Detection Interrupt generation

**Bit 5: FAULT1\_INT\_EN** – FAULT[1] Pin Interrupt Enable

0 = Disables Fault Detection Interrupt generation (Default)

1 = Enables Fault Detection Interrupt generation

**Bit 4: FAULT0\_INT\_EN** – FAULT[0] Pin Interrupt Enable

0 = Disables Fault Detection Interrupt generation (Default)

1 = Enables Fault Detection Interrupt generation

**Bit 3: FAULT3\_DET\_EN** – FAULT[3] Pin Detection Enable

0 = Fault Detection Disabled (Default)

1 = Fault Detection Enabled

**Bit 2: FAULT2\_DET\_EN** – FAULT[2] Pin Detection Enable

0 = Fault Detection Disabled (Default)

1 = Fault Detection Enabled

**Bit 1: FAULT1\_DET\_EN** – FAULT[1] Pin Detection Enable

0 = Fault Detection Disabled (Default)

1 = Fault Detection Enabled

**Bit 0: FAULT0\_DET\_EN** – FAULT[0] Pin Detection Enable

0 = Fault Detection Disabled (Default)

1 = Fault Detection Enabled

### A.2.6 Fault Mux Interrupt Status Register (FAULTMUXINTSTAT)

Address 00030014

Bit Number	16	15	14	13	12
Bit Name	DCOMP3	DCOMP2	DCOMP1	DCOMP0	LFO_FAIL
Access	R	R	R	R	R
Default	-	-	-	-	-

Bit Number	11	10	9	8	7	6
Bit Name	FAULT3	FAULT2	FAULT1	FAULT0	DCM_DETECT	ACOMP_G
Access	R	R	R	R	R	R
Default	-	-	-	-	-	-

Bit Number	5	4	3	2	1	0
Bit Name	ACOMP_F	ACOMP_E	ACOMP_D	ACOMP_C	ACOMP_B	ACOMP_A
Access	R	R	R	R	R	R
Default	-	-	-	-	-	-

**Bit 16: DCOMP3** – Digital Comparator 3 Interrupt Status, cleared by read of status register

0 = Comparator threshold interrupt disabled

1 = Comparator threshold interrupt enabled

**Bit 15: DCOMP2** – Digital Comparator 2 Interrupt Status, cleared by read of status register

0 = Comparator threshold interrupt disabled

1 = Comparator threshold interrupt enabled

**Bit 14: DCOMP1** – Digital Comparator 1 Interrupt Status, cleared by read of status register

0 = Comparator threshold interrupt disabled

1 = Comparator threshold interrupt enabled

**Bit 13: DCOMP0** – Digital Comparator 0 Interrupt Status, cleared by read of status register

0 = Comparator threshold interrupt disabled

1 = Comparator threshold interrupt enabled

**Bit 12: LFO\_FAIL**– Low Frequency Oscillator Failure Interrupt Status, cleared by read of status register

0 = Low Frequency Oscillator operational

1 = Low Frequency Oscillator failure detected

**Bit 11: FAULT3** – External FAULT[2] Interrupt Detection

0 = No External GPIO detection found

1 = External GPIO detection found

**Bit 10: FAULT2** – External FAULT[2] Interrupt Detection

0 = No External GPIO detection found

1 = External GPIO detection found

**Bit 9: FAULT1** – External FAULT[1] Interrupt Detection

0 = No External GPIO detection found

1 = External GPIO detection found

**Bit 8: FAULT0** – External FAULT[0] Interrupt Detection

0 = No External GPIO detection found

1 = External GPIO detection found

**Bit 7: DCM\_DETECT** – Discontinuous Conduction Mode Interrupt Status, cleared by read of status register

0 = Discontinuous Conduction Mode detected



- 1 = Discontinuous Conduction Mode not detected
- Bit 6: ACOMP\_G** – Analog Comparator G Interrupt Status, cleared by read of status register  
0 = Comparator threshold interrupt disabled  
1 = Comparator threshold interrupt enabled
- Bit 5: ACOMP\_F** – Analog Comparator F Interrupt Status, cleared by read of status register  
0 = Comparator threshold interrupt disabled  
1 = Comparator threshold interrupt enabled
- Bit 4: ACOMP\_E** – Analog Comparator E Interrupt Status, cleared by read of status register  
0 = Comparator threshold interrupt disabled  
1 = Comparator threshold interrupt enabled
- Bit 3: ACOMP\_D** – Analog Comparator D Interrupt Status, cleared by read of status register  
0 = Comparator threshold interrupt disabled  
1 = Comparator threshold interrupt enabled
- Bit 2: ACOMP\_C** – Analog Comparator C Interrupt Status, cleared by read of status register  
0 = Comparator threshold interrupt disabled  
1 = Comparator threshold interrupt enabled
- Bit 1: ACOMP\_B** – Analog Comparator B Interrupt Status, cleared by read of status register  
0 = Comparator threshold interrupt disabled  
1 = Comparator threshold interrupt enabled
- Bit 0: ACOMP\_A** – Analog Comparator A Interrupt Status, cleared by read of status register  
0 = Comparator threshold interrupt disabled  
1 = Comparator threshold interrupt enabled

### A.2.7 Fault Mux Raw Status Register (FAULTMUXRAWSTAT)

Address 00030018

Bit Number	16	15	14	13	12
Bit Name	DCOMP3	DCOMP2	DCOMP1	DCOMP0	LFO_FAIL
Access	R	R	R	R	R
Default	-	-	-	-	-

Bit Number	11	10	9	8	7	6
Bit Name	FAULT3	FAULT2	FAULT1	FAULT0	DCM_DETECT	ACOMP_G
Access	R	R	R	R	R	R
Default	-	-	-	-	-	-

Bit Number	5	4	3	2	1	0
Bit Name	ACOMP_F	ACOMP_E	ACOMP_D	ACOMP_C	ACOMP_B	ACOMP_A
Access	R	R	R	R	R	R
Default	-	-	-	-	-	-

- Bit 16: DCOMP3** – Digital Comparator 3 Raw Status  
0 = Comparator threshold not exceeded  
1 = Comparator threshold exceeded
- Bit 15: DCOMP2** – Digital Comparator 2 Raw Status  
0 = Comparator threshold not exceeded  
1 = Comparator threshold exceeded
- Bit 14: DCOMP1** – Digital Comparator 1 Raw Status  
0 = Comparator threshold not exceeded  
1 = Comparator threshold exceeded
- Bit 13: DCOMP0** – Digital Comparator 0 Raw Status  
0 = Comparator threshold not exceeded

- 1 = Comparator threshold exceeded
- Bit 12: LFO\_FAIL** – Low Frequency Oscillator Failure Raw Status
  - 0 = Low Frequency Oscillator operational
  - 1 = Low Frequency Oscillator failure detected
- Bit 11: FAULT3** – External Fault Detection on FAULT[3] pin
  - 0 = No External FAULT[2] detection found
  - 1 = External GPIO detection found
- Bit 10: FAULT2** – External Fault Detection on FAULT[2] pin
  - 0 = No External FAULT[2] detection found
  - 1 = External GPIO detection found
- Bit 9: FAULT1** – External Fault Detection on FAULT[1] pin
  - 0 = No External FAULT[1] detection found
  - 1 = External GPIO detection found
- Bit 8: FAULT0** – External Fault Detection on FAULT[0] pin
  - 0 = No External FAULT[0] detection found
  - 1 = External GPIO detection found
- Bit 7: DCM\_DETECT** – Discontinuous Conduction Mode Raw Status
  - 0 = Discontinuous Conduction Mode detected
  - 1 = Discontinuous Conduction Mode not detected
- Bit 6: ACOMP\_G** – Analog Comparator G Raw Result
  - 0 = Comparator threshold not exceeded
  - 1 = Comparator threshold exceeded
- Bit 5: ACOMP\_F** – Analog Comparator F Raw Result
  - 0 = Comparator threshold not exceeded
  - 1 = Comparator threshold exceeded
- Bit 4: ACOMP\_E** – Analog Comparator E Raw Result
  - 0 = Comparator threshold not exceeded
  - 1 = Comparator threshold exceeded
- Bit 3: ACOMP\_D** – Analog Comparator D Raw Result
  - 0 = Comparator threshold not exceeded
  - 1 = Comparator threshold exceeded
- Bit 2: ACOMP\_C** – Analog Comparator C Raw Result
  - 0 = Comparator threshold not exceeded
  - 1 = Comparator threshold exceeded
- Bit 1: ACOMP\_B** – Analog Comparator B Raw Result
  - 0 = Comparator threshold not exceeded
  - 1 = Comparator threshold exceeded
- Bit 0: ACOMP\_A** – Analog Comparator A Raw Result
  - 0 = Comparator threshold not exceeded
  - 1 = Comparator threshold exceeded

**A.2.8 Comparator Ramp Control 0 Register (COMPRAMP0)**

Address 0003001C

Bit Number	31:28	27:10
Bit Name	START_VALUE_SEL	STEP_SIZE
Access	R/W	R/W
Default	0000	00_0000_0000_0000_0000

Bit Number	9:5	4	3
Bit Name	CLKS_PER_STEP	DPWM3_TRIG_EN	DPWM2_TRIG_EN
Access	R/W	R/W	R/W
Default	0_0000	0	00

Bit Number	2	1	0
Bit Name	DPWM1_TRIG_EN	DPWM0_TRIG_EN	RAMP_EN
Access	R/W	R/W	R/W
Default	00	00	0

**Bits 31-28: START\_VALUE\_SEL** – Configures comparator ramp starting value

- 0 = Filter 0 Output (Bits 17-11) (Default)
- 1 = Filter 1 Output (Bits 17-11)
- 2 = Filter 2 Output (Bits 17-11)
- 3 = Analog Comparator Threshold A Value
- 4 = Analog Comparator Threshold B Value
- 5 = Analog Comparator Threshold C Value
- 6 = Analog Comparator Threshold D Value
- 7 = Analog Comparator Threshold E Value
- 8 = Analog Comparator Threshold F Value
- 9 = Analog Comparator Threshold G Value

**Bits 27-10: STEP\_SIZE** - Programmable 18-bit unsigned comparator step with Bits 27:24 representing the integer portion of the comparator step (0-15 Comparator steps of 19.5mV each) and Bits 23:10 representing the fractional portion of the comparator step

**Bits 9-5: CLKS\_PER\_STEP** – Selects number of MCLK (HFO\_OSC/8) clock cycles per comparator step where number of subcycles can vary from 1 to 32

- 0 = 1 MCLK clock cycles per step (Default)
- 1 = 2 MCLK clock cycles per step
- 2 = 3 MCLK clock cycles per step
- .....
- 31 = 32 MCLK clock cycles per step

**Bit 4: DPWM3\_TRIG\_EN** – Enables DPWM Trigger from DPWM 3 to Analog Comparator Ramp 0

- 0 = DPWM 3 trigger not routed to Analog Comparator Ramp 0 (Default)
- 1 = DPWM 3 trigger routed to Analog Comparator Ramp 0

**Bit 3: DPWM2\_TRIG\_EN** – Enables DPWM Trigger from DPWM 2 to Analog Comparator Ramp 0

- 0 = DPWM 2 trigger not routed to Analog Comparator Ramp 0 (Default)
- 1 = DPWM 2 trigger routed to Analog Comparator Ramp 0

**Bit 2: DPWM1\_TRIG\_EN** – Enables DPWM Trigger from DPWM 1 to Analog Comparator Ramp 0

- 0 = DPWM 1 trigger not routed to Analog Comparator Ramp 0 (Default)
- 1 = DPWM 1 trigger routed to Analog Comparator Ramp 0

**Bit 1: DPWM0\_TRIG\_EN** – Enables DPWM Trigger from DPWM 0 to Analog Comparator Ramp 0

- 0 = DPWM 0 trigger not routed to Analog Comparator Ramp 0 (Default)
- 1 = DPWM 0 trigger routed to Analog Comparator Ramp 0

**Bit 0: RAMP\_EN** – Enable for Analog Comparator Ramp 0  
 0 = Analog Comparator Ramp disabled (Default)  
 1 = Analog Comparator Ramp enabled

### A.2.9 Digital Comparator Control 0 Register (DCOMPCTRL0)

Address 0x00030020

Bit Number	31:24	23:19	18	17:15	14
Bit Name	CNT_THRESH	RESERVED	COMP_POL	FE_SEL	CNT_CLR
Access	R/W	-	R/W	R/W	R/W
Default	0000_0000	0000_0	0	000	0

Bit Number	13	12	11	10:0
Bit Name	CNT_CONFIG	INT_EN	COMP_EN	THRESH
Access	R/W	R/W	R/W	R/W
Default	0	0	0	000_0000_0000

**Bits 31-24: CNT\_THRESH** – Sets the number of received comparator events before declaring a fault

**Bits 23-19: RESERVED** – Unused bits

**Bit 18: COMP\_POL** – Digital Comparator 0 Polarity

0 = Digital Comparator result asserted if value below threshold (Default)

1 = Digital Comparator result asserted if value above threshold

**Bits 17-15: FE\_SEL** – Selects which Front End absolute data is used for Digital Comparison with threshold

0 = Front End 0 absolute data selected (Default)

1 = Front End 1 absolute data selected

2 = Front End 2 absolute data selected

3 = Front End 0 error data selected

4 = Front End 1 error data selected

5 = Front End 2 error data selected

**Bit 14: CNT\_CLR** – Comparator Detection Counter clear

0 = No clear of Comparator Detection Counter (Default)

1 = Clear Comparator Detection counter and associated fault

**Bit 13: CNT\_CONFIG** – Comparator Detection Counter configuration

0 = Counter clears upon receipt of sample which does not exceed comparator threshold (Default)

1 = Counter decrements by 1 upon receipt of sample which does not exceed comparator threshold

**Bit 12: INT\_EN** – Comparator Interrupt Enable

0 = Disables Comparator Interrupt generation (Default)

1 = Enables Comparator Interrupt generation

**Bit 11: COMP\_EN** – Digital Comparator 0 Enable

0 = Disables Digital Comparator 0 (Default)

1 = Enables Digital Comparator 0

**Bits 10-0: THRESH** – Sets the digital comparator threshold, 11-bit signed value with resolution of 1.5625mV/bit

### A.2.10 Digital Comparator Control 1 Register (DCOMPCTRL1)

Address 0x00030024

Bit Number	31:24	23:19	18	17:15	14
Bit Name	CNT_THRESH	RESERVED	COMP_POL	FE_SEL	CNT_CLR
Access	R/W	-	R/W	R/W	R/W
Default	0000_0000	0000_0	0	000	0

Bit Number	13	12	11	10:0
Bit Name	CNT_CONFIG	INT_EN	COMP_EN	THRESH
Access	R/W	R/W	R/W	R/W
Default	0	0	0	000_0000_0000

**Bits 31-24: CNT\_THRESH** – Sets the number of received comparator events before declaring a fault

**Bits 23-19: RESERVED** – Unused bits

**Bit 18: COMP\_POL** – Digital Comparator 1 Polarity

0 = Digital Comparator result asserted if value below threshold (Default)

1 = Digital Comparator result asserted if value above threshold

**Bits 17-15: FE\_SEL** – Selects which Front End absolute data is used for Digital Comparison with threshold

0 = Front End 0 absolute data selected (Default)

1 = Front End 1 absolute data selected

2 = Front End 2 absolute data selected

3 = Front End 0 error data selected

4 = Front End 1 error data selected

5 = Front End 2 error data selected

**Bit 14: CNT\_CLR** – Comparator Detection Counter clear

0 = No clear of Comparator Detection Counter (Default)

1 = Clear Comparator Detection counter and associated fault

**Bit 13: CNT\_CONFIG** – Comparator Detection Counter configuration

0 = Counter clears upon receipt of sample which does not exceed comparator threshold (Default)

1 = Counter decrements by 1 upon receipt of sample which does not exceed comparator threshold

**Bit 12: INT\_EN** – Comparator Interrupt Enable

0 = Disables Comparator Interrupt generation (Default)

1 = Enables Comparator Interrupt generation

**Bit 11: COMP\_EN** – Digital Comparator 1 Enable

0 = Disables Digital Comparator 1 (Default)

1 = Enables Digital Comparator 1

**Bits 10-0: THRESH** – Sets the digital comparator threshold, 11-bit signed value with resolution of 1.5625mV/bit

### A.2.11 Digital Comparator Control 2 Register (DCOMPCTRL2)

Address 0x00030028

Bit Number	31:24	23:19	18	17:15	14
Bit Name	CNT_THRESH	RESERVED	COMP_POL	FE_SEL	CNT_CLR
Access	R/W	-	R/W	R/W	R/W
Default	0000_0000	0000_0	0	000	0

Bit Number	13	12	11	10:0
Bit Name	CNT_CONFIG	INT_EN	COMP_EN	THRESH
Access	R/W	R/W	R/W	R/W
Default	0	0	0	000_0000_0000

**Bits 31-24: CNT\_THRESH** – Sets the number of received comparator events before declaring a fault

**Bits 23-19: RESERVED** – Unused bits

**Bit 18: COMP\_POL** – Digital Comparator 1 Polarity

0 = Digital Comparator result asserted if value below threshold (Default)

1 = Digital Comparator result asserted if value above threshold

**Bits 17-15: FE\_SEL** – Selects which Front End absolute data is used for Digital Comparison with threshold

0 = Front End 0 absolute data selected (Default)

- 1 = Front End 1 absolute data selected
- 2 = Front End 2 absolute data selected
- 3 = Front End 0 error data selected
- 4 = Front End 1 error data selected
- 5 = Front End 2 error data selected
- Bit 14: CNT\_CLR** – Comparator Detection Counter clear
  - 0 = No clear of Comparator Detection Counter (Default)
  - 1 = Clear Comparator Detection counter and associated fault
- Bit 13: CNT\_CONFIG** – Comparator Detection Counter configuration
  - 0 = Counter clears upon receipt of sample which does not exceed comparator threshold (Default)
  - 1 = Counter decrements by 1 upon receipt of sample which does not exceed comparator threshold
- Bit 12: INT\_EN** – Comparator Interrupt Enable
  - 0 = Disables Comparator Interrupt generation (Default)
  - 1 = Enables Comparator Interrupt generation
- Bit 11: COMP\_EN** – Digital Comparator 2 Enable
  - 0 = Disables Digital Comparator 2 (Default)
  - 1 = Enables Digital Comparator 2
- Bits 10-0: THRESH** – Sets the digital comparator threshold, 11-bit signed value with resolution of 1.5625mV/bit

### A.2.12 Digital Comparator Control 3 Register (DCOMPCTRL3)

Address 0x0003002C

Bit Number	31:24	23:19	18	17:15	14
Bit Name	CNT_THRESH	RESERVED	COMP_POL	FE_SEL	CNT_CLR
Access	R/W	-	R/W	R/W	R/W
Default	0000_0000	0000_0	0	000	0

Bit Number	13	12	11	10:0
Bit Name	CNT_CONFIG	INT_EN	COMP_EN	THRESH
Access	R/W	R/W	R/W	R/W
Default	0	0	0	000_0000_0000

- Bits 31-24: CNT\_THRESH** – Sets the number of received comparator events before declaring a fault
- Bits 23-19: RESERVED** – Unused bits
- Bit 18: COMP\_POL** – Digital Comparator 1 Polarity
  - 0 = Digital Comparator result asserted if value below threshold (Default)
  - 1 = Digital Comparator result asserted if value above threshold
- Bits 17-15: FE\_SEL** – Selects which Front End absolute data is used for Digital Comparison with threshold
  - 0 = Front End 0 absolute data selected (Default)
  - 1 = Front End 1 absolute data selected
  - 2 = Front End 2 absolute data selected
  - 3 = Front End 0 error data selected
  - 4 = Front End 1 error data selected
  - 5 = Front End 2 error data selected
- Bit 14: CNT\_CLR** – Comparator Detection Counter clear
  - 0 = No clear of Comparator Detection Counter (Default)
  - 1 = Clear Comparator Detection counter and associated fault
- Bit 13: CNT\_CONFIG** – Comparator Detection Counter configuration
  - 0 = Counter clears upon receipt of sample which does not exceed comparator threshold (Default)
  - 1 = Counter decrements by 1 upon receipt of sample which does not exceed comparator threshold
- Bit 12: INT\_EN** – Comparator Interrupt Enable
  - 0 = Disables Comparator Interrupt generation (Default)

- 1 = Enables Comparator Interrupt generation  
**Bit 11: COMP\_EN** – Digital Comparator 3 Enable  
 0 = Disables Digital Comparator 3 (Default)  
 1 = Enables Digital Comparator 3  
**Bits 10-0: THRESH** – Sets the digital comparator threshold, 11-bit signed value with resolution of 1.5625mV/bit

### A.2.13 Digital Comparator Counter Status Register (DCOMPNTSTAT)

Address 0x00030030

Bit Number	31:24	31:24	31:24	31:24
Bit Name	DCOMP3_CNT	DCOMP2_CNT	DCOMP1_CNT	DCOMP0_CNT
Access	R	R	R	R
Default	-	-	-	-

- Bits 31-24: DCOMP3\_CNT** – Current value of Digital Comparator 3 detection counter  
**Bits 23-16: DCOMP2\_CNT** – Current value of Digital Comparator 2 detection counter  
**Bits 15-8: DCOMP1\_CNT** – Current value of Digital Comparator 1 detection counter  
**Bits 7-0: DCOMP0\_CNT** – Current value of Digital Comparator 0 detection counter

### A.2.14 DPWM 0 Current Limit Control Register (DPWM0CLIM)

Address 0x00030034

Bit Number	16	15	14
Bit Name	ANALOG_PCM_EN	DCOMP3_EN	DCOMP2_EN
Access	R/W	R/W	R/W
Default	0	0	0

Bit Number	13	12	11	10	9
Bit Name	DCOMP1_EN	DCOMP0_EN	RESERVED	FAULT3_EN	FAULT2_EN
Access	R/W	R/W	R	R/W	R/W
Default	0	0	0	0	0

Bit Number	8	7	6	5	4
Bit Name	FAULT1_EN	FAULT0_EN	ACOMP_G_EN	ACOMP_F_EN	ACOMP_E_EN
Access	R/W	R/W	R/W	R/W	R/W
Default	0	0	0	0	0

Bit Number	3	2	1	0
Bit Name	ACOMP_D_EN	ACOMP_C_EN	ACOMP_B_EN	ACOMP_A_EN
Access	R/W	R/W	R/W	R/W
Default	0	0	0	0

- Bit 16: ANALOG\_PCM\_EN** – Enables Analog Peak Current detection result for DPWM 0 Current Limit  
 0 = Analog Peak Current detection disabled for current limit (Default)  
 1 = Analog Peak Current detection enabled for current limit  
**Bit 15: DCOMP3\_EN** – Enables Digital Comparator 3 result for DPWM 0 Current Limit  
 0 = Digital Comparator 3 result disabled for current limit (Default)  
 1 = Digital Comparator 3 result enabled for current limit  
**Bit 14: DCOMP2\_EN** – Enables Digital Comparator 2 result for DPWM 0 Current Limit

0 = Digital Comparator 2 result disabled for current limit (Default)

1 = Digital Comparator 2 result enabled for current limit

**Bit 13: DCOMP1\_EN** – Enables Digital Comparator 1 result for DPWM 0 Current Limit

0 = Digital Comparator 1 result disabled for current limit (Default)

1 = Digital Comparator 1 result enabled for current limit

**Bit 12: DCOMP0\_EN** – Enables Digital Comparator 0 result for DPWM 0 Current Limit

0 = Digital Comparator 0 result disabled for current limit (Default)

1 = Digital Comparator 0 result enabled for current limit

**Bit 11: RESERVED** – Unused Bit

**Bit 10: FAULT3\_EN** – Enables FAULT[3] pin for DPWM 0 Current Limit

0 = External Fault pin disabled for current limit (Default)

1 = External Fault pin enabled for current limit

**Bit 9: FAULT2\_EN** – Enables FAULT[2] pin for DPWM 0 Current Limit

0 = External Fault pin disabled for current limit (Default)

1 = External Fault pin enabled for current limit

**Bit 8: FAULT1\_EN** – Enables FAULT[1] pin for DPWM 0 Current Limit

0 = External Fault pin disabled for current limit (Default)

1 = External Fault pin enabled for current limit

**Bit 7: FAULT0\_EN** – Enables FAULT[0] pin for DPWM 0 Current Limit

0 = External Fault pin disabled for current limit (Default)

1 = External Fault pin enabled for current limit

**Bit 6: ACOMP\_G\_EN** – Enables Analog Comparator G result for DPWM 0 Current Limit

0 = Analog Comparator result disabled for current limit (Default)

1 = Analog Comparator result enabled for current limit

**Bit 5: ACOMP\_F\_EN** – Enables Analog Comparator F result for DPWM 0 Current Limit

0 = Analog Comparator result disabled for current limit (Default)

1 = Analog Comparator result enabled for current limit

**Bit 4: ACOMP\_E\_EN** – Enables Analog Comparator E result for DPWM 0 Current Limit

0 = Analog Comparator result disabled for current limit (Default)

1 = Analog Comparator result enabled for current limit

**Bit 3: ACOMP\_D\_EN** – Enables Analog Comparator D result for DPWM 0 Current Limit

0 = Analog Comparator result disabled for current limit (Default)

1 = Analog Comparator result enabled for current limit

**Bit 2: ACOMP\_C\_EN** – Enables Analog Comparator C result for DPWM 0 Current Limit

0 = Analog Comparator result disabled for current limit (Default)

1 = Analog Comparator result enabled for current limit

**Bit 1: ACOMP\_B\_EN** – Enables Analog Comparator B result for DPWM 0 Current Limit

0 = Analog Comparator result disabled for current limit (Default)

1 = Analog Comparator result enabled for current limit

**Bit 0: ACOMP\_A\_EN** – Enables Analog Comparator A result for DPWM 0 Current Limit

0 = Analog Comparator result disabled for current limit (Default)

1 = Analog Comparator result enabled for current limit

### A.2.15 DPWM 0 Fault AB Detection Register (DPWM0FLTABDET)

Address 0x00030038

Bit Number	14	13	12	11	10
Bit Name	DCOMP3_EN	DCOMP2_EN	DCOMP1_EN	DCOMP0_EN	FAULT3_EN
Access	R/W	R/W	R/W	R/W	R/W
Default	0	0	0	0	0

Bit Number	9	8	7	6	5
Bit Name	FAULT2_EN	FAULT1_EN	FAULT0_EN	ACOMP_G_EN	ACOMP_F_EN



<b>Access</b>	R/W	R/W	R/W	R/W	R/W
<b>Default</b>	0	0	0	0	0

<b>Bit Number</b>	<b>4</b>	<b>3</b>	<b>2</b>	<b>1</b>	<b>0</b>
<b>Bit Name</b>	ACOMP_E_EN	ACOMP_D_EN	ACOMP_C_EN	ACOMP_B_EN	ACOMP_A_EN
<b>Access</b>	R/W	R/W	R/W	R/W	R/W
<b>Default</b>	0	0	0	0	0

- Bit 14: DCOMP3\_EN** – Enables Digital Comparator 3 result for DPWM 0 Fault AB Detection  
 0 = Digital Comparator 3 disabled for Fault AB detection (Default)  
 1 = Digital Comparator 3 enabled for Fault AB detection
- Bit 13: DCOMP2\_EN** – Enables Digital Comparator 2 result for DPWM 0 Fault AB Detection  
 0 = Digital Comparator 2 disabled for Fault AB detection (Default)  
 1 = Digital Comparator 2 enabled for Fault AB detection
- Bit 12: DCOMP1\_EN** – Enables Digital Comparator 1 result for DPWM 0 Fault AB Detection  
 0 = Digital Comparator 1 disabled for Fault AB detection (Default)  
 1 = Digital Comparator 1 enabled for Fault AB detection
- Bit 11: DCOMP0\_EN** – Enables Digital Comparator 0 result for DPWM 0 Fault AB Detection  
 0 = Digital Comparator 0 disabled for Fault AB detection (Default)  
 1 = Digital Comparator 0 enabled for Fault AB detection
- Bit 10: FAULT3\_EN** – Enables FAULT[3] pin for DPWM 0 Fault AB detection  
 0 = External Fault pin disabled for Fault AB detection (Default)  
 1 = External Fault pin enabled for Fault AB detection
- Bit 9: FAULT2\_EN** – Enables FAULT[2] pin for DPWM 0 Fault AB detection  
 0 = External Fault pin disabled for Fault AB detection (Default)  
 1 = External Fault pin enabled for Fault AB detection
- Bit 8: FAULT1\_EN** – Enables FAULT[1] pin for DPWM 0 Fault AB detection  
 0 = External Fault pin disabled for Fault AB detection (Default)  
 1 = External Fault pin enabled for Fault AB detection
- Bit 7: FAULT0\_EN** – Enables FAULT[0] pin for DPWM 0 Fault AB detection  
 0 = External Fault pin disabled for Fault AB detection (Default)  
 1 = External Fault pin enabled for Fault AB detection
- Bit 6: ACOMP\_A\_EN** – Enables Analog Comparator G result for DPWM 0 Fault AB detection  
 0 = Analog Comparator result disabled for Fault AB detection (Default)  
 1 = Analog Comparator result enabled for Fault AB detection
- Bit 5: ACOMP\_F\_EN** – Enables Analog Comparator F result for DPWM 0 Fault AB detection  
 0 = Analog Comparator result disabled for Fault AB detection (Default)  
 1 = Analog Comparator result enabled for Fault AB detection
- Bit 4: ACOMP\_E\_EN** – Enables Analog Comparator E result for DPWM 0 Fault AB detection  
 0 = Analog Comparator result disabled for Fault AB detection (Default)  
 1 = Analog Comparator result enabled for Fault AB detection
- Bit 3: ACOMP\_D\_EN** – Enables Analog Comparator D result for DPWM 0 Fault AB detection  
 0 = Analog Comparator result disabled for Fault AB detection (Default)  
 1 = Analog Comparator result enabled for Fault AB detection
- Bit 2: ACOMP\_C\_EN** – Enables Analog Comparator C result for DPWM 0 Fault AB detection  
 0 = Analog Comparator result disabled for Fault AB detection (Default)  
 1 = Analog Comparator result enabled for Fault AB detection
- Bit 1: ACOMP\_B\_EN** – Enables Analog Comparator B result for DPWM 0 Fault AB detection  
 0 = Analog Comparator result disabled for Fault AB detection (Default)  
 1 = Analog Comparator result enabled for Fault AB detection
- Bit 0: ACOMP\_A\_EN** – Enables Analog Comparator A result for DPWM 0 Fault AB detection  
 0 = Analog Comparator result disabled for Fault AB detection (Default)  
 1 = Analog Comparator result enabled for Fault AB detection

### A.2.16 DPWM 0 Fault Detection Register (DPWM0FAULTDET)

Address 0x0003003C

Bit Number	30	29	28
Bit Name	PWMB_DCOMP3_EN	PWMB_DCOMP2_EN	PWMB_DCOMP1_EN
Access	R/W	R/W	R/W
Default	0	0	0

Bit Number	27	26	25
Bit Name	PWMB_DCOMP0_EN	PWMB_FAULT3_EN	PWMB_FAULT2_EN
Access	R/W	R/W	R/W
Default	0	0	0

Bit Number	24	23	22
Bit Name	PWMB_FAULT1_EN	PWMB_FAULT0_EN	PWMB_ACOMP_G_EN
Access	R/W	R/W	R/W
Default	0	0	0

Bit Number	21	20	19
Bit Name	PWMB_ACOMP_F_EN	PWMB_ACOMP_E_EN	PWMB_ACOMP_D_EN
Access	R/W	R/W	R/W
Default	0	0	0

Bit Number	18	17	16
Bit Name	PWMB_ACOMP_C_EN	PWMB_ACOMP_B_EN	PWMB_ACOMP_A_EN
Access	R/W	R/W	R/W
Default	0	0	0

Bit Number	15	14
Bit Name	RESERVED	PWMA_DCOMP3_EN
Access	-	R/W
Default	0	0

Bit Number	13	12	11
Bit Name	PWMA_DCOMP2_EN	PWMA_DCOMP1_EN	PWMA_DCOMP0_EN
Access	R/W	R/W	R/W
Default	0	0	0

Bit Number	10	9
Bit Name	PWMA_FAULT3_EN	PWMA_FAULT2_EN
Access	R/W	R/W
Default	0	0

Bit Number	8	7	6
Bit Name	PWMA_FAULT1_EN	PWMA_FAULT0_EN	PWMA_ACOMP_G_EN
Access	R/W	R/W	R/W
Default	0	0	0

Bit Number	5	4	3
Bit Name	PWMA_ACOMP_F_EN	PWMA_ACOMP_E_EN	PWMA_ACOMP_D_EN
Access	R/W	R/W	R/W
Default	0	0	0

Bit Number	2	1	0
Bit Name	PWMA_ACOMP_C_EN	PWMA_ACOMP_B_EN	PWMA_ACOMP_A_EN
Access	R/W	R/W	R/W
Default	0	0	0

- Bit 30: PWMB\_DCOMP3\_EN** – Enables Digital Comparator 3 result for DPWM 0 PWM-B Fault Detection  
 0 = Digital Comparator 3 disabled for fault detection (Default)  
 1 = Digital Comparator 3 enabled for fault detection
- Bit 29: PWMB\_DCOMP2\_EN** – Enables Digital Comparator 2 result for DPWM 0 PWM-B Fault Detection  
 0 = Digital Comparator 2 disabled for fault detection (Default)  
 1 = Digital Comparator 2 enabled for fault detection
- Bit 28: PWMB\_DCOMP1\_EN** – Enables Digital Comparator 1 result for DPWM 0 PWM-B Fault Detection  
 0 = Digital Comparator 1 disabled for fault detection (Default)  
 1 = Digital Comparator 1 enabled for fault detection
- Bit 27: PWMB\_DCOMP0\_EN** – Enables Digital Comparator 0 result for DPWM 0 PWM-B Fault Detection  
 0 = Digital Comparator 0 disabled for fault detection (Default)  
 1 = Digital Comparator 0 enabled for fault detection
- Bit 26: PWMB\_FAULT3\_EN** – Enables FAULT[3] pin for DPWM 0 PWM-B Fault Detection  
 0 = External Fault pin disabled for fault detection (Default)  
 1 = External Fault pin enabled for fault detection
- Bit 25: PWMB\_FAULT2\_EN** – Enables FAULT[2] pin for DPWM 0 PWM-B Fault Detection  
 0 = External Fault pin disabled for fault detection (Default)  
 1 = External Fault pin enabled for fault detection
- Bit 24: PWMB\_FAULT1\_EN** – Enables FAULT[1] pin for DPWM 0 PWM-B Fault Detection  
 0 = External Fault pin disabled for fault detection (Default)  
 1 = External Fault pin enabled for fault detection
- Bit 23: PWMB\_FAULT0\_EN** – Enables FAULT[0] pin for DPWM 0 PWM-B Fault Detection  
 0 = External Fault pin disabled for fault detection (Default)  
 1 = External Fault pin enabled for fault detection
- Bit 22: PWMB\_ACOMP\_G\_EN** – Enables Analog Comparator G result for DPWM 0 PWM-B Fault detection  
 0 = Analog Comparator result disabled for fault detection (Default)  
 1 = Analog Comparator result enabled for fault detection
- Bit 21: PWMB\_ACOMP\_F\_EN** – Enables Analog Comparator F result for DPWM 0 PWM-B Fault detection  
 0 = Analog Comparator result disabled for fault detection (Default)  
 1 = Analog Comparator result enabled for fault detection
- Bit 20: PWMB\_ACOMP\_E\_EN** – Enables Analog Comparator E result for DPWM 0 PWM-B Fault detection  
 0 = Analog Comparator result disabled for fault detection (Default)  
 1 = Analog Comparator result enabled for fault detection
- Bit 19: PWMB\_ACOMP\_D\_EN** – Enables Analog Comparator D result for DPWM 0 PWM-B Fault detection  
 0 = Analog Comparator result disabled for fault detection (Default)  
 1 = Analog Comparator result enabled for fault detection

- Bit 18: PWMB\_ACOMP\_C\_EN** – Enables Analog Comparator C result for DPWM 0 PWM-B Fault detection  
 0 = Analog Comparator result disabled for fault detection (Default)  
 1 = Analog Comparator result enabled for fault detection
- Bit 17: PWMB\_ACOMP\_B\_EN** – Enables Analog Comparator B result for DPWM 0 PWM-B Fault detection  
 0 = Analog Comparator result disabled for fault detection (Default)  
 1 = Analog Comparator result enabled for fault detection
- Bit 16: PWMB\_ACOMP\_A\_EN** – Enables Analog Comparator A result for DPWM 0 PWM-B Fault detection  
 0 = Analog Comparator result disabled for fault detection (Default)  
 1 = Analog Comparator result enabled for fault detection
- Bit 15: RESERVED** – Unused bit
- Bit 14: PWMA\_DCOMP3\_EN** – Enables Digital Comparator 3 result for DPWM 0 PWM-A Fault Detection  
 0 = Digital Comparator 3 disabled for fault detection (Default)  
 1 = Digital Comparator 3 enabled for fault detection
- Bit 13: PWMA\_DCOMP2\_EN** – Enables Digital Comparator 2 result for DPWM 0 PWM-A Fault Detection  
 0 = Digital Comparator 2 disabled for fault detection (Default)  
 1 = Digital Comparator 2 enabled for fault detection
- Bit 12: PWMA\_DCOMP1\_EN** – Enables Digital Comparator 1 result for DPWM 0 PWM-A Fault Detection  
 0 = Digital Comparator 1 disabled for fault detection (Default)  
 1 = Digital Comparator 1 enabled for fault detection
- Bit 11: PWMA\_DCOMP0\_EN** – Enables Digital Comparator 0 result for DPWM 0 PWM-A Fault Detection  
 0 = Digital Comparator 0 disabled for fault detection (Default)  
 1 = Digital Comparator 0 enabled for fault detection
- Bit 10: PWMA\_FAULT3\_EN** – Enables FAULT[3] pin for DPWM 0 PWM-A Fault Detection  
 0 = External Fault pin disabled for fault detection (Default)  
 1 = External Fault pin enabled for fault detection
- Bit 9: PWMA\_FAULT2\_EN** – Enables FAULT[2] pin for DPWM 0 PWM-A Fault Detection  
 0 = External Fault pin disabled for fault detection (Default)  
 1 = External Fault pin enabled for fault detection
- Bit 8: PWMA\_FAULT1\_EN** – Enables FAULT[1] pin for DPWM 0 PWM-A Fault Detection  
 0 = External Fault pin disabled for fault detection (Default)  
 1 = External Fault pin enabled for fault detection
- Bit 7: PWMA\_FAULT0\_EN** – Enables FAULT[0] pin for DPWM 0 PWM-A Fault Detection  
 0 = External Fault pin disabled for fault detection (Default)  
 1 = External Fault pin enabled for fault detection
- Bit 6: PWMA\_ACOMP\_G\_EN** – Enables Analog Comparator G result for DPWM 0 PWM-A Fault detection  
 0 = Analog Comparator result disabled for fault detection (Default)  
 1 = Analog Comparator result enabled for fault detection
- Bit 5: PWMA\_ACOMP\_F\_EN** – Enables Analog Comparator F result for DPWM 0 PWM-A Fault detection  
 0 = Analog Comparator result disabled for fault detection (Default)  
 1 = Analog Comparator result enabled for fault detection
- Bit 4: PWMA\_ACOMP\_E\_EN** – Enables Analog Comparator E result for DPWM 0 PWM-A Fault detection  
 0 = Analog Comparator result disabled for fault detection (Default)  
 1 = Analog Comparator result enabled for fault detection
- Bit 3: PWMA\_ACOMP\_D\_EN** – Enables Analog Comparator D result for DPWM 0 PWM-A Fault detection  
 0 = Analog Comparator result disabled for fault detection (Default)  
 1 = Analog Comparator result enabled for fault detection
- Bit 2: PWMA\_ACOMP\_C\_EN** – Enables Analog Comparator C result for DPWM 0 PWM-A Fault detection  
 0 = Analog Comparator result disabled for fault detection (Default)  
 1 = Analog Comparator result enabled for fault detection
- Bit 1: PWMA\_ACOMP\_B\_EN** – Enables Analog Comparator B result for DPWM 0 PWM-A Fault detection  
 0 = Analog Comparator result disabled for fault detection (Default)  
 1 = Analog Comparator result enabled for fault detection
- Bit 0: PWMA\_ACOMP\_A\_EN** – Enables Analog Comparator A result for DPWM 0 PWM-A Fault detection  
 0 = Analog Comparator result disabled for fault detection (Default)

---

1 = Analog Comparator result enabled for fault detection

### A.2.17 DPWM 0 IDE Detection Register (DPWM0IDEDET)

Address 0x00030040

Bit Number	6	5	4	3
Bit Name	ACOMP_G_EN	ACOMP_F_EN	ACOMP_E_EN	ACOMP_D_EN
Access	R/W	R/W	R/W	R/W
Default	0	0	0	0

Bit Number	2	1	0
Bit Name	ACOMP_C_EN	ACOMP_B_EN	ACOMP_A_EN
Access	R/W	R/W	R/W
Default	0	0	0

**Bit 6: ACOMP\_6\_EN** – Enables Analog Comparator G result for DPWM 0 IDE detection  
 0 = Analog Comparator result disabled for IDE detection (Default)  
 1 = Analog Comparator result enabled for IDE detection

**Bit 5: ACOMP\_5\_EN** – Enables Analog Comparator F result for DPWM 0 IDE detection

0 = Analog Comparator result disabled for IDE detection (Default)  
 1 = Analog Comparator result enabled for IDE detection

**Bit 4: ACOMP\_4\_EN** – Enables Analog Comparator E result for DPWM 0 IDE detection

0 = Analog Comparator result disabled for IDE detection (Default)  
 1 = Analog Comparator result enabled for IDE detection

**Bit 3: ACOMP\_3\_EN** – Enables Analog Comparator D result for DPWM 0 IDE detection

0 = Analog Comparator result disabled for IDE detection (Default)  
 1 = Analog Comparator result enabled for IDE detection

**Bit 2: ACOMP\_2\_EN** – Enables Analog Comparator C result for DPWM 0 IDE detection

0 = Analog Comparator result disabled for IDE detection (Default)  
 1 = Analog Comparator result enabled for IDE detection

**Bit 1: ACOMP\_1\_EN** – Enables Analog Comparator B result for DPWM 0 IDE detection

0 = Analog Comparator result disabled for IDE detection (Default)  
 1 = Analog Comparator result enabled for IDE detection

**Bit 0: ACOMP\_0\_EN** – Enables Analog Comparator A result for DPWM 0 IDE detection

0 = Analog Comparator result disabled for IDE detection (Default)  
 1 = Analog Comparator result enabled for IDE detection

**A.2.18 DPWM 1 Current Limit Control Register (DPWM1CLIM)**

Address 0x00030044

Bit Number	16	15	14
Bit Name	ANALOG_PCM_EN	DCOMP3_EN	DCOMP2_EN
Access	R/W	R/W	R/W
Default	0	0	0

Bit Number	13	12	11	10	9
Bit Name	DCOMP1_EN	DCOMP0_EN	RESERVED	FAULT3_EN	FAULT2_EN
Access	R/W	R/W	R	R/W	R/W
Default	0	0	0	0	0

Bit Number	8	7	6	5	4
Bit Name	FAULT1_EN	FAULT0_EN	ACOMP_G_EN	ACOMP_F_EN	ACOMP_E_EN
Access	R/W	R/W	R/W	R/W	R/W
Default	0	0	0	0	0

Bit Number	3	2	1	0
Bit Name	ACOMP_D_EN	ACOMP_C_EN	ACOMP_B_EN	ACOMP_A_EN
Access	R/W	R/W	R/W	R/W
Default	0	0	0	0

**Bit 16: ANALOG\_PCM\_EN** – Enables Analog Peak Current detection result for DPWM 1 Current Limit

0 = Analog Peak Current detection disabled for current limit (Default)

1 = Analog Peak Current detection enabled for current limit

**Bit 15: DCOMP3\_EN** – Enables Digital Comparator 3 result for DPWM 1 Current Limit

0 = Digital Comparator 3 result disabled for current limit (Default)

1 = Digital Comparator 3 result enabled for current limit

**Bit 14: DCOMP2\_EN** – Enables Digital Comparator 2 result for DPWM 1 Current Limit

0 = Digital Comparator 2 result disabled for current limit (Default)

1 = Digital Comparator 2 result enabled for current limit

**Bit 13: DCOMP1\_EN** – Enables Digital Comparator 1 result for DPWM 1 Current Limit

0 = Digital Comparator 1 result disabled for current limit (Default)

1 = Digital Comparator 1 result enabled for current limit

**Bit 12: DCOMP0\_EN** – Enables Digital Comparator 0 result for DPWM 1 Current Limit

0 = Digital Comparator 0 result disabled for current limit (Default)

1 = Digital Comparator 0 result enabled for current limit

**Bit 11: Reserved** – Unused Bit

**Bit 10: FAULT3\_EN** – Enables FAULT[3] pin for DPWM 1 Current Limit

0 = External Fault pin disabled for current limit (Default)

1 = External Fault pin enabled for current limit

**Bit 9: FAULT2\_EN** – Enables FAULT[2] pin for DPWM 1 Current Limit

0 = External Fault pin disabled for current limit (Default)

1 = External Fault pin enabled for current limit

**Bit 8: FAULT1\_EN** – Enables FAULT[1] pin for DPWM 1 Current Limit

0 = External Fault pin disabled for current limit (Default)

1 = External Fault pin enabled for current limit

**Bit 7: FAULT0\_EN** – Enables FAULT[0] pin for DPWM 1 Current Limit

0 = External Fault pin disabled for current limit (Default)

1 = External Fault pin enabled for current limit

**Bit 6: ACOMP\_G\_EN** – Enables Analog Comparator G result for DPWM 1 Current Limit

0 = Analog Comparator result disabled for current limit (Default)

1 = Analog Comparator result enabled for current limit

**Bit 5: ACOMP\_F\_EN** – Enables Analog Comparator F result for DPWM 1 Current Limit

0 = Analog Comparator result disabled for current limit (Default)

1 = Analog Comparator result enabled for current limit

**Bit 4: ACOMP\_E\_EN** – Enables Analog Comparator E result for DPWM 1 Current Limit

0 = Analog Comparator result disabled for current limit (Default)

1 = Analog Comparator result enabled for current limit

**Bit 3: ACOMP\_D\_EN** – Enables Analog Comparator D result for DPWM 1 Current Limit

0 = Analog Comparator result disabled for current limit (Default)

1 = Analog Comparator result enabled for current limit

**Bit 2: ACOMP\_C\_EN** – Enables Analog Comparator C result for DPWM 1 Current Limit

0 = Analog Comparator result disabled for current limit (Default)

1 = Analog Comparator result enabled for current limit

**Bit 1: ACOMP\_B\_EN** – Enables Analog Comparator B result for DPWM 1 Current Limit

0 = Analog Comparator result disabled for current limit (Default)

1 = Analog Comparator result enabled for current limit

**Bit 0: ACOMP\_A\_EN** – Enables Analog Comparator A result for DPWM 1 Current Limit

0 = Analog Comparator result disabled for current limit (Default)

1 = Analog Comparator result enabled for current limit



**A.2.19 DPWM 1 Fault AB Detection Register (DPWM1FLTABDET)**
**Address 0x00030048**

Bit Number	14	13	12	11	10
Bit Name	DCOMP3_EN	DCOMP2_EN	DCOMP1_EN	DCOMP0_EN	FAULT3_EN
Access	R/W	R/W	R/W	R/W	R/W
Default	0	0	0	0	0

Bit Number	9	8	7	6	5
Bit Name	FAULT2_EN	FAULT1_EN	FAULT0_EN	ACOMP_G_EN	ACOMP_F_EN
Access	R/W	R/W	R/W	R/W	R/W
Default	0	0	0	0	0

Bit Number	4	3	2	1	0
Bit Name	ACOMP_E_EN	ACOMP_D_EN	ACOMP_C_EN	ACOMP_B_EN	ACOMP_A_EN
Access	R/W	R/W	R/W	R/W	R/W
Default	0	0	0	0	0

- Bit 14: DCOMP3\_EN** – Enables Digital Comparator 3 result for DPWM 1 Fault AB Detection  
0 = Digital Comparator 3 disabled for Fault AB detection (Default)  
1 = Digital Comparator 3 enabled for Fault AB detection
- Bit 13: DCOMP2\_EN** – Enables Digital Comparator 2 result for DPWM 1 Fault AB Detection  
0 = Digital Comparator 2 disabled for Fault AB detection (Default)  
1 = Digital Comparator 2 enabled for Fault AB detection
- Bit 12: DCOMP1\_EN** – Enables Digital Comparator 1 result for DPWM 1 Fault AB Detection  
0 = Digital Comparator 1 disabled for Fault AB detection (Default)  
1 = Digital Comparator 1 enabled for Fault AB detection
- Bit 11: DCOMP0\_EN** – Enables Digital Comparator 0 result for DPWM 1 Fault AB Detection  
0 = Digital Comparator 0 disabled for Fault AB detection (Default)  
1 = Digital Comparator 0 enabled for Fault AB detection
- Bit 10: FAULT3\_EN** – Enables FAULT[3] pin for DPWM 1 Fault AB detection  
0 = External Fault pin disabled for Fault AB detection (Default)  
1 = External Fault pin enabled for Fault AB detection
- Bit 9: FAULT2\_EN** – Enables FAULT[2] pin for DPWM 1 Fault AB detection  
0 = External Fault pin disabled for Fault AB detection (Default)  
1 = External Fault pin enabled for Fault AB detection
- Bit 8: FAULT1\_EN** – Enables FAULT[1] pin for DPWM 1 Fault AB detection  
0 = External Fault pin disabled for Fault AB detection (Default)  
1 = External Fault pin enabled for Fault AB detection
- Bit 7: FAULT0\_EN** – Enables FAULT[0] pin for DPWM 1 Fault AB detection  
0 = External Fault pin disabled for Fault AB detection (Default)  
1 = External Fault pin enabled for Fault AB detection
- Bit 6: ACOMP\_G\_EN** – Enables Analog Comparator G result for DPWM 1 Fault AB detection  
0 = Analog Comparator result disabled for Fault AB detection (Default)  
1 = Analog Comparator result enabled for Fault AB detection
- Bit 5: ACOMP\_F\_EN** – Enables Analog Comparator F result for DPWM 1 Fault AB detection  
0 = Analog Comparator result disabled for Fault AB detection (Default)  
1 = Analog Comparator result enabled for Fault AB detection
- Bit 4: ACOMP\_E\_EN** – Enables Analog Comparator E result for DPWM 1 Fault AB detection  
0 = Analog Comparator result disabled for Fault AB detection (Default)

- 1 = Analog Comparator result enabled for Fault AB detection
- Bit 3: ACOMP\_D\_EN** – Enables Analog Comparator D result for DPWM 1 Fault AB detection  
0 = Analog Comparator result disabled for Fault AB detection (Default)
- 1 = Analog Comparator result enabled for Fault AB detection
- Bit 2: ACOMP\_C\_EN** – Enables Analog Comparator C result for DPWM 1 Fault AB detection  
0 = Analog Comparator result disabled for Fault AB detection (Default)
- 1 = Analog Comparator result enabled for Fault AB detection
- Bit 1: ACOMP\_B\_EN** – Enables Analog Comparator B result for DPWM 1 Fault AB detection  
0 = Analog Comparator result disabled for Fault AB detection (Default)
- 1 = Analog Comparator result enabled for Fault AB detection
- Bit 0: ACOMP\_A\_EN** – Enables Analog Comparator A result for DPWM 1 Fault AB detection  
0 = Analog Comparator result disabled for Fault AB detection (Default)  
1 = Analog Comparator result enabled for Fault AB detection

**A.2.20 DPWM 1 Fault Detection Register (DPWM1FAULTDET)**

Address 0x0003004C

Bit Number	30	29	28
Bit Name	PWMB_DCOMP3_EN	PWMB_DCOMP2_EN	PWMB_DCOMP1_EN
Access	R/W	R/W	R/W
Default	0	0	0

Bit Number	27	26	25
Bit Name	PWMB_DCOMP0_EN	PWMB_FAULT3_EN	PWMB_FAULT2_EN
Access	R/W	R/W	R/W
Default	0	0	0

Bit Number	24	23	22
Bit Name	PWMB_FAULT1_EN	PWMB_FAULT0_EN	PWMB_ACOMP_G_EN
Access	R/W	R/W	R/W
Default	0	0	0

Bit Number	21	20	19
Bit Name	PWMB_ACOMP_F_EN	PWMB_ACOMP_E_EN	PWMB_ACOMP_D_EN
Access	R/W	R/W	R/W
Default	0	0	0

Bit Number	18	17	16
Bit Name	PWMB_ACOMP_C_EN	PWMB_ACOMP_B_EN	PWMB_ACOMP_A_EN
Access	R/W	R/W	R/W
Default	0	0	0

Bit Number	15	14
Bit Name	RESERVED	PWMA_DCOMP3_EN
Access	-	R/W
Default	0	0

Bit Number	13	12	11
Bit Name	PWMA_DCOMP2_EN	PWMA_DCOMP1_EN	PWMA_DCOMP0_EN
Access	R/W	R/W	R/W
Default	0	0	0

Bit Number	10	9
Bit Name	PWMA_FAULT3_EN	PWMA_FAULT2_EN
Access	R/W	R/W
Default	0	0

Bit Number	8	7	6
Bit Name	PWMA_FAULT1_EN	PWMA_FAULT0_EN	PWMA_ACOMP_G_EN
Access	R/W	R/W	R/W
Default	0	0	0

Bit Number	5	4	3
Bit Name	PWMA_ACOMP_F_EN	PWMA_ACOMP_E_EN	PWMA_ACOMP_D_EN
Access	R/W	R/W	R/W
Default	0	0	0

Bit Number	2	1	0
Bit Name	PWMA_ACOMP_C_EN	PWMA_ACOMP_B_EN	PWMA_ACOMP_A_EN
Access	R/W	R/W	R/W
Default	0	0	0

- Bit 30: PWMB\_DCOMP3\_EN** – Enables Digital Comparator 3 result for DPWM 1 PWM-B Fault Detection  
0 = Digital Comparator 3 disabled for fault detection (Default)  
1 = Digital Comparator 3 enabled for fault detection
- Bit 29: PWMB\_DCOMP2\_EN** – Enables Digital Comparator 2 result for DPWM 1 PWM-B Fault Detection  
0 = Digital Comparator 2 disabled for fault detection (Default)  
1 = Digital Comparator 2 enabled for fault detection
- Bit 28: PWMB\_DCOMP1\_EN** – Enables Digital Comparator 1 result for DPWM 1 PWM-B Fault Detection  
0 = Digital Comparator 1 disabled for fault detection (Default)  
1 = Digital Comparator 1 enabled for fault detection
- Bit 27: PWMB\_DCOMP0\_EN** – Enables Digital Comparator 0 result for DPWM 1 PWM-B Fault Detection  
0 = Digital Comparator 0 disabled for fault detection (Default)  
1 = Digital Comparator 0 enabled for fault detection
- Bit 26: PWMB\_FAULT3\_EN** – Enables FAULT[3] pin for DPWM 1 PWM-B Fault Detection  
0 = External Fault pin disabled for fault detection (Default)  
1 = External Fault pin enabled for fault detection
- Bit 25: PWMB\_FAULT2\_EN** – Enables FAULT[2] pin for DPWM 1 PWM-B Fault Detection  
0 = External Fault pin disabled for fault detection (Default)  
1 = External Fault pin enabled for fault detection
- Bit 24: PWMB\_FAULT1\_EN** – Enables FAULT[1] pin for DPWM 1 PWM-B Fault Detection  
0 = External Fault pin disabled for fault detection (Default)  
1 = External Fault pin enabled for fault detection
- Bit 23: PWMB\_FAULT0\_EN** – Enables FAULT[0] pin for DPWM 1 PWM-B Fault Detection  
0 = External Fault pin disabled for fault detection (Default)  
1 = External Fault pin enabled for fault detection
- Bit 22: PWMB\_ACOMP\_G\_EN** – Enables Analog Comparator G result for DPWM 1 PWM-B Fault detection  
0 = Analog Comparator result disabled for fault detection (Default)  
1 = Analog Comparator result enabled for fault detection
- Bit 21: PWMB\_ACOMP\_F\_EN** – Enables Analog Comparator F result for DPWM 1 PWM-B Fault detection  
0 = Analog Comparator result disabled for fault detection (Default)  
1 = Analog Comparator result enabled for fault detection
- Bit 20: PWMB\_ACOMP\_E\_EN** – Enables Analog Comparator E result for DPWM 1 PWM-B Fault detection  
0 = Analog Comparator result disabled for fault detection (Default)  
1 = Analog Comparator result enabled for fault detection
- Bit 19: PWMB\_ACOMP\_D\_EN** – Enables Analog Comparator D result for DPWM 1 PWM-B Fault detection  
0 = Analog Comparator result disabled for fault detection (Default)  
1 = Analog Comparator result enabled for fault detection

- Bit 18: PWMB\_ACOMP\_C\_EN** – Enables Analog Comparator C result for DPWM 1 PWM-B Fault detection  
 0 = Analog Comparator result disabled for fault detection (Default)  
 1 = Analog Comparator result enabled for fault detection
- Bit 17: PWMB\_ACOMP\_B\_EN** – Enables Analog Comparator B result for DPWM 1 PWM-B Fault detection  
 0 = Analog Comparator result disabled for fault detection (Default)  
 1 = Analog Comparator result enabled for fault detection
- Bit 16: PWMB\_ACOMP\_A\_EN** – Enables Analog Comparator A result for DPWM 1 PWM-B Fault detection  
 0 = Analog Comparator result disabled for fault detection (Default)  
 1 = Analog Comparator result enabled for fault detection
- Bit 15: RESERVED** – Unused bit
- Bit 14: PWMA\_DCOMP3\_EN** – Enables Digital Comparator 3 result for DPWM 1 PWM-A Fault Detection  
 0 = Digital Comparator 3 disabled for fault detection (Default)  
 1 = Digital Comparator 3 enabled for fault detection
- Bit 13: PWMA\_DCOMP2\_EN** – Enables Digital Comparator 2 result for DPWM 1 PWM-A Fault Detection  
 0 = Digital Comparator 2 disabled for fault detection (Default)  
 1 = Digital Comparator 2 enabled for fault detection
- Bit 12: PWMA\_DCOMP1\_EN** – Enables Digital Comparator 1 result for DPWM 1 PWM-A Fault Detection  
 0 = Digital Comparator 1 disabled for fault detection (Default)  
 1 = Digital Comparator 1 enabled for fault detection
- Bit 11: PWMA\_DCOMP0\_EN** – Enables Digital Comparator 0 result for DPWM 1 PWM-A Fault Detection  
 0 = Digital Comparator 0 disabled for fault detection (Default)  
 1 = Digital Comparator 0 enabled for fault detection
- Bit 10: PWMA\_FAULT2\_EN** – Enables FAULT[2] pin for DPWM 1 PWM-A Fault Detection  
 0 = External Fault pin disabled for fault detection (Default)  
 1 = External Fault pin enabled for fault detection
- Bit 9: PWMA\_FAULT1\_EN** – Enables FAULT[1] pin for DPWM 1 PWM-A Fault Detection  
 0 = External Fault pin disabled for fault detection (Default)  
 1 = External Fault pin enabled for fault detection
- Bit 8: PWMA\_FAULT0\_EN** – Enables FAULT[0] pin for DPWM 1 PWM-A Fault Detection  
 0 = External Fault pin disabled for fault detection (Default)  
 1 = External Fault pin enabled for fault detection
- Bit 7: PWMA\_ACOMP\_G\_EN** – Enables Analog Comparator G result for DPWM 1 PWM-A Fault detection  
 0 = Analog Comparator result disabled for fault detection (Default)  
 1 = Analog Comparator result enabled for fault detection
- Bit 6: PWMA\_ACOMP\_F\_EN** – Enables Analog Comparator F result for DPWM 1 PWM-A Fault detection  
 0 = Analog Comparator result disabled for fault detection (Default)  
 1 = Analog Comparator result enabled for fault detection
- Bit 5: PWMA\_ACOMP\_E\_EN** – Enables Analog Comparator E result for DPWM 1 PWM-A Fault detection  
 0 = Analog Comparator result disabled for fault detection (Default)  
 1 = Analog Comparator result enabled for fault detection
- Bit 4: PWMA\_ACOMP\_D\_EN** – Enables Analog Comparator D result for DPWM 1 PWM-A Fault detection  
 0 = Analog Comparator result disabled for fault detection (Default)  
 1 = Analog Comparator result enabled for fault detection
- Bit 3: PWMA\_ACOMP\_C\_EN** – Enables Analog Comparator C result for DPWM 1 PWM-A Fault detection  
 0 = Analog Comparator result disabled for fault detection (Default)  
 1 = Analog Comparator result enabled for fault detection
- Bit 2: PWMA\_ACOMP\_B\_EN** – Enables Analog Comparator B result for DPWM 1 PWM-A Fault detection  
 0 = Analog Comparator result disabled for fault detection (Default)  
 1 = Analog Comparator result enabled for fault detection
- Bit 1: PWMA\_ACOMP\_A\_EN** – Enables Analog Comparator A result for DPWM 1 PWM-A Fault detection  
 0 = Analog Comparator result disabled for fault detection (Default)  
 1 = Analog Comparator result enabled for fault detection
- Bit 0: PWMA\_ACOMP\_A\_EN** – Enables Analog Comparator A result for DPWM 1 PWM-A Fault detection  
 0 = Analog Comparator result disabled for fault detection (Default)

---

1 = Analog Comparator result enabled for fault detection

**A.2.21 DPWM 1 IDE Detection Register (DPWM1IDEDET)**

Address 0x00030050

Bit Number	6	5	4	3
Bit Name	ACOMP_G_EN	ACOMP_F_EN	ACOMP_E_EN	ACOMP_D_EN
Access	R/W	R/W	R/W	R/W
Default	0	0	0	0

Bit Number	2	1	0
Bit Name	ACOMP_C_EN	ACOMP_B_EN	ACOMP_A_EN
Access	R/W	R/W	R/W
Default	0	0	0

**Bit 6: ACOMP\_6\_EN** – Enables Analog Comparator G result for DPWM 1 IDE detection  
 0 = Analog Comparator result disabled for IDE detection (Default)  
 1 = Analog Comparator result enabled for IDE detection

**Bit 5: ACOMP\_5\_EN** – Enables Analog Comparator F result for DPWM 1 IDE detection  
 0 = Analog Comparator result disabled for IDE detection (Default)  
 1 = Analog Comparator result enabled for IDE detection

**Bit 4: ACOMP\_4\_EN** – Enables Analog Comparator E result for DPWM 1 IDE detection  
 0 = Analog Comparator result disabled for IDE detection (Default)  
 1 = Analog Comparator result enabled for IDE detection

**Bit 3: ACOMP\_3\_EN** – Enables Analog Comparator D result for DPWM 1 IDE detection  
 0 = Analog Comparator result disabled for IDE detection (Default)  
 1 = Analog Comparator result enabled for IDE detection

**Bit 2: ACOMP\_2\_EN** – Enables Analog Comparator C result for DPWM 1 IDE detection  
 0 = Analog Comparator result disabled for IDE detection (Default)  
 1 = Analog Comparator result enabled for IDE detection

**Bit 1: ACOMP\_1\_EN** – Enables Analog Comparator B result for DPWM 1 IDE detection  
 0 = Analog Comparator result disabled for IDE detection (Default)  
 1 = Analog Comparator result enabled for IDE detection

**Bit 0: ACOMP\_0\_EN** – Enables Analog Comparator A result for DPWM 1 IDE detection  
 0 = Analog Comparator result disabled for IDE detection (Default)  
 1 = Analog Comparator result enabled for IDE detection

**A.2.2 DPWM 2 Current Limit Control Register (DPWM2CLIM)**

Address 0x00030054

Bit Number	16	15	14
Bit Name	ANALOG_PCM_EN	DCOMP3_EN	DCOMP2_EN
Access	R/W	R/W	R/W
Default	0	0	0

Bit Number	13	12	11	10	9
Bit Name	DCOMP1_EN	DCOMP0_EN	RESERVED	FAULT3_EN	FAULT2_EN
Access	R/W	R/W	R	R/W	R/W
Default	0	0	0	0	0

Bit Number	8	7	6	5	4
Bit Name	FAULT1_EN	FAULT0_EN	ACOMP_G_EN	ACOMP_F_EN	ACOMP_E_EN
Access	R/W	R/W	R/W	R/W	R/W
Default	0	0	0	0	0

Bit Number	3	2	1	0
Bit Name	ACOMP_D_EN	ACOMP_C_EN	ACOMP_B_EN	ACOMP_A_EN
Access	R/W	R/W	R/W	R/W
Default	0	0	0	0

**Bit 16: ANALOG\_PCM\_EN** – Enables Analog Peak Current detection result for DPWM 2 Current Limit  
 0 = Analog Peak Current detection disabled for current limit (Default)  
 1 = Analog Peak Current detection enabled for current limit

**Bit 15: DCOMP3\_EN** – Enables Digital Comparator 3 result for DPWM 2 Current Limit  
 0 = Digital Comparator 3 result disabled for current limit (Default)  
 1 = Digital Comparator 3 result enabled for current limit

**Bit 14: DCOMP2\_EN** – Enables Digital Comparator 2 result for DPWM 2 Current Limit  
 0 = Digital Comparator 2 result disabled for current limit (Default)  
 1 = Digital Comparator 2 result enabled for current limit

**Bit 13: DCOMP1\_EN** – Enables Digital Comparator 1 result for DPWM 2 Current Limit  
 0 = Digital Comparator 1 result disabled for current limit (Default)  
 1 = Digital Comparator 1 result enabled for current limit

**Bit 12: DCOMP0\_EN** – Enables Digital Comparator 0 result for DPWM 2 Current Limit  
 0 = Digital Comparator 0 result disabled for current limit (Default)  
 1 = Digital Comparator 0 result enabled for current limit

**Bit 11: RESERVED** – Unused Bit

**Bit 10: FAULT3\_EN** – Enables FAULT[3] pin for DPWM 2 Current Limit  
 0 = External Fault pin disabled for current limit (Default)  
 1 = External Fault pin enabled for current limit

**Bit 9: FAULT2\_EN** – Enables FAULT[2] pin for DPWM 2 Current Limit  
 0 = External Fault pin disabled for current limit (Default)  
 1 = External Fault pin enabled for current limit

**Bit 8: FAULT1\_EN** – Enables FAULT[1] pin for DPWM 2 Current Limit  
 0 = External Fault pin disabled for current limit (Default)  
 1 = External Fault pin enabled for current limit

**Bit 7: FAULT0\_EN** – Enables FAULT[0] pin for DPWM 2 Current Limit



0 = External Fault pin disabled for current limit (Default)

1 = External Fault pin enabled for current limit

**Bit 6: ACOMP\_G\_EN** – Enables Analog Comparator G result for DPWM 2 Current Limit

0 = Analog Comparator result disabled for current limit (Default)

1 = Analog Comparator result enabled for current limit

**Bit 5: ACOMP\_F\_EN** – Enables Analog Comparator F result for DPWM 2 Current Limit

0 = Analog Comparator result disabled for current limit (Default)

1 = Analog Comparator result enabled for current limit

**Bit 4: ACOMP\_E\_EN** – Enables Analog Comparator E result for DPWM 2 Current Limit

0 = Analog Comparator result disabled for current limit (Default)

1 = Analog Comparator result enabled for current limit

**Bit 3: ACOMP\_D\_EN** – Enables Analog Comparator D result for DPWM 2 Current Limit

0 = Analog Comparator result disabled for current limit (Default)

1 = Analog Comparator result enabled for current limit

**Bit 2: ACOMP\_C\_EN** – Enables Analog Comparator C result for DPWM 2 Current Limit

0 = Analog Comparator result disabled for current limit (Default)

1 = Analog Comparator result enabled for current limit

**Bit 1: ACOMP\_B\_EN** – Enables Analog Comparator B result for DPWM 2 Current Limit

0 = Analog Comparator result disabled for current limit (Default)

1 = Analog Comparator result enabled for current limit

**Bit 0: ACOMP\_A\_EN** – Enables Analog Comparator A result for DPWM 2 Current Limit

0 = Analog Comparator result disabled for current limit (Default)

1 = Analog Comparator result enabled for current limit

### A.2.23 DPWM 2 Fault AB Detection Register (DPWM2FLTABDET)

Address 0x00030058

Bit Number	14	13	12	11	10
Bit Name	DCOMP3_EN	DCOMP2_EN	DCOMP1_EN	DCOMP0_EN	FAULT3_EN
Access	R/W	R/W	R/W	R/W	R/W
Default	0	0	0	0	0

Bit Number	9	8	7	6	5
Bit Name	FAULT2_EN	FAULT1_EN	FAULT0_EN	ACOMP_G_EN	ACOMP_F_EN
Access	R/W	R/W	R/W	R/W	R/W
Default	0	0	0	0	0

Bit Number	4	3	2	1	0
Bit Name	ACOMP_E_EN	ACOMP_D_EN	ACOMP_C_EN	ACOMP_B_EN	ACOMP_A_EN
Access	R/W	R/W	R/W	R/W	R/W
Default	0	0	0	0	0

- Bit 14: DCOMP3\_EN** – Enables Digital Comparator 3 result for DPWM 2 Fault AB Detection  
 0 = Digital Comparator 3 disabled for Fault AB detection (Default)  
 1 = Digital Comparator 3 enabled for Fault AB detection
- Bit 13: DCOMP2\_EN** – Enables Digital Comparator 2 result for DPWM 2 Fault AB Detection  
 0 = Digital Comparator 2 disabled for Fault AB detection (Default)  
 1 = Digital Comparator 2 enabled for Fault AB detection
- Bit 12: DCOMP1\_EN** – Enables Digital Comparator 1 result for DPWM 2 Fault AB Detection  
 0 = Digital Comparator 1 disabled for Fault AB detection (Default)  
 1 = Digital Comparator 1 enabled for Fault AB detection
- Bit 11: DCOMP0\_EN** – Enables Digital Comparator 0 result for DPWM 2 Fault AB Detection  
 0 = Digital Comparator 0 disabled for Fault AB detection (Default)  
 1 = Digital Comparator 0 enabled for Fault AB detection
- Bit 10: FAULT3\_EN** – Enables FAULT[3] pin for DPWM 2 Fault AB detection  
 0 = External Fault pin disabled for Fault AB detection (Default)  
 1 = External Fault pin enabled for Fault AB detection
- Bit 9: FAULT2\_EN** – Enables FAULT[2] pin for DPWM 2 Fault AB detection  
 0 = External Fault pin disabled for Fault AB detection (Default)  
 1 = External Fault pin enabled for Fault AB detection
- Bit 8: FAULT1\_EN** – Enables FAULT[1] pin for DPWM 2 Fault AB detection  
 0 = External Fault pin disabled for Fault AB detection (Default)  
 1 = External Fault pin enabled for Fault AB detection
- Bit 7: FAULT0\_EN** – Enables FAULT[0] pin for DPWM 2 Fault AB detection  
 0 = External Fault pin disabled for Fault AB detection (Default)  
 1 = External Fault pin enabled for Fault AB detection
- Bit 6: ACOMP\_G\_EN** – Enables Analog Comparator G result for DPWM 2 Fault AB detection  
 0 = Analog Comparator result disabled for Fault AB detection (Default)  
 1 = Analog Comparator result enabled for Fault AB detection
- Bit 5: ACOMP\_F\_EN** – Enables Analog Comparator F result for DPWM 2 Fault AB detection  
 0 = Analog Comparator result disabled for Fault AB detection (Default)  
 1 = Analog Comparator result enabled for Fault AB detection
- Bit 4: ACOMP\_E\_EN** – Enables Analog Comparator E result for DPWM 2 Fault AB detection  
 0 = Analog Comparator result disabled for Fault AB detection (Default)

- 
- 1 = Analog Comparator result enabled for Fault AB detection
- Bit 3: ACOMP\_D\_EN** – Enables Analog Comparator D result for DPWM 2 Fault AB detection  
0 = Analog Comparator result disabled for Fault AB detection (Default)  
1 = Analog Comparator result enabled for Fault AB detection
- Bit 2: ACOMP\_C\_EN** – Enables Analog Comparator C result for DPWM 2 Fault AB detection  
0 = Analog Comparator result disabled for Fault AB detection (Default)  
1 = Analog Comparator result enabled for Fault AB detection
- Bit 1: ACOMP\_B\_EN** – Enables Analog Comparator B result for DPWM 2 Fault AB detection  
0 = Analog Comparator result disabled for Fault AB detection (Default)  
1 = Analog Comparator result enabled for Fault AB detection
- Bit 0: ACOMP\_A\_EN** – Enables Analog Comparator A result for DPWM 2 Fault AB detection  
0 = Analog Comparator result disabled for Fault AB detection (Default)  
1 = Analog Comparator result enabled for Fault AB detection

### A.2.24 DPWM 2 Fault Detection Register (DPWM2FAULTDET)

Address 0x0003005C

Bit Number	30	29	28
Bit Name	PWMB_DCOMP3_EN	PWMB_DCOMP2_EN	PWMB_DCOMP1_EN
Access	R/W	R/W	R/W
Default	0	0	0

Bit Number	27	26	25
Bit Name	PWMB_DCOMP0_EN	PWMB_FAULT3_EN	PWMB_FAULT2_EN
Access	R/W	R/W	R/W
Default	0	0	0

Bit Number	24	23	22
Bit Name	PWMB_FAULT1_EN	PWMB_FAULT0_EN	PWMB_ACOMP_G_EN
Access	R/W	R/W	R/W
Default	0	0	0

Bit Number	21	20	19
Bit Name	PWMB_ACOMP_F_EN	PWMB_ACOMP_E_EN	PWMB_ACOMP_D_EN
Access	R/W	R/W	R/W
Default	0	0	0

Bit Number	18	17	16
Bit Name	PWMB_ACOMP_C_EN	PWMB_ACOMP_B_EN	PWMB_ACOMP_A_EN
Access	R/W	R/W	R/W
Default	0	0	0

Bit Number	15	14
Bit Name	RESERVED	PWMA_DCOMP3_EN
Access	-	R/W
Default	0	0

Bit Number	13	12	11
Bit Name	PWMA_DCOMP2_EN	PWMA_DCOMP1_EN	PWMA_DCOMP0_EN
Access	R/W	R/W	R/W
Default	0	0	0

Bit Number	10	9
Bit Name	PWMA_FAULT3_EN	PWMA_FAULT2_EN
Access	R/W	R/W
Default	0	0

Bit Number	8	7	6
Bit Name	PWMA_FAULT1_EN	PWMA_FAULT0_EN	PWMA_ACOMP_G_EN
Access	R/W	R/W	R/W
Default	0	0	0

Bit Number	5	4	3
Bit Name	PWMA_ACOMP_F_EN	PWMA_ACOMP_E_EN	PWMA_ACOMP_D_EN
Access	R/W	R/W	R/W
Default	0	0	0

Bit Number	2	1	0
Bit Name	PWMA_ACOMP_C_EN	PWMA_ACOMP_B_EN	PWMA_ACOMP_A_EN
Access	R/W	R/W	R/W
Default	0	0	0

- Bit 30: PWMB\_DCOMP3\_EN** – Enables Digital Comparator 3 result for DPWM 2 PWM-B Fault Detection  
0 = Digital Comparator 3 disabled for fault detection (Default)  
1 = Digital Comparator 3 enabled for fault detection
- Bit 29: PWMB\_DCOMP2\_EN** – Enables Digital Comparator 2 result for DPWM 2 PWM-B Fault Detection  
0 = Digital Comparator 2 disabled for fault detection (Default)  
1 = Digital Comparator 2 enabled for fault detection
- Bit 28: PWMB\_DCOMP1\_EN** – Enables Digital Comparator 1 result for DPWM 2 PWM-B Fault Detection  
0 = Digital Comparator 1 disabled for fault detection (Default)  
1 = Digital Comparator 1 enabled for fault detection
- Bit 27: PWMB\_DCOMP0\_EN** – Enables Digital Comparator 0 result for DPWM 2 PWM-B Fault Detection  
0 = Digital Comparator 0 disabled for fault detection (Default)  
1 = Digital Comparator 0 enabled for fault detection
- Bit 26: PWMB\_FAULT3\_EN** – Enables FAULT[3] pin for DPWM 2 PWM-B Fault Detection  
0 = External Fault pin disabled for fault detection (Default)  
1 = External Fault pin enabled for fault detection
- Bit 25: PWMB\_FAULT2\_EN** – Enables FAULT[2] pin for DPWM 2 PWM-B Fault Detection  
0 = External Fault pin disabled for fault detection (Default)  
1 = External Fault pin enabled for fault detection
- Bit 24: PWMB\_FAULT1\_EN** – Enables FAULT[1] pin for DPWM 2 PWM-B Fault Detection  
0 = External Fault pin disabled for fault detection (Default)  
1 = External Fault pin enabled for fault detection
- Bit 23: PWMB\_FAULT0\_EN** – Enables FAULT[0] pin for DPWM 2 PWM-B Fault Detection  
0 = External Fault pin disabled for fault detection (Default)  
1 = External Fault pin enabled for fault detection
- Bit 22: PWMB\_ACOMP\_G\_EN** – Enables Analog Comparator G result for DPWM 2 PWM-B Fault detection  
0 = Analog Comparator result disabled for fault detection (Default)  
1 = Analog Comparator result enabled for fault detection
- Bit 21: PWMB\_ACOMP\_F\_EN** – Enables Analog Comparator F result for DPWM 2 PWM-B Fault detection  
0 = Analog Comparator result disabled for fault detection (Default)  
1 = Analog Comparator result enabled for fault detection
- Bit 20: PWMB\_ACOMP\_E\_EN** – Enables Analog Comparator E result for DPWM 2 PWM-B Fault detection  
0 = Analog Comparator result disabled for fault detection (Default)  
1 = Analog Comparator result enabled for fault detection
- Bit 19: PWMB\_ACOMP\_D\_EN** – Enables Analog Comparator D result for DPWM 2 PWM-B Fault detection  
0 = Analog Comparator result disabled for fault detection (Default)  
1 = Analog Comparator result enabled for fault detection

- Bit 18: PWMB\_ACOMP\_C\_EN** – Enables Analog Comparator C result for DPWM 2 PWM-B Fault detection  
 0 = Analog Comparator result disabled for fault detection (Default)  
 1 = Analog Comparator result enabled for fault detection
- Bit 17: PWMB\_ACOMP\_B\_EN** – Enables Analog Comparator B result for DPWM 2 PWM-B Fault detection  
 0 = Analog Comparator result disabled for fault detection (Default)  
 1 = Analog Comparator result enabled for fault detection
- Bit 16: PWMB\_ACOMP\_A\_EN** – Enables Analog Comparator A result for DPWM 2 PWM-B Fault detection  
 0 = Analog Comparator result disabled for fault detection (Default)  
 1 = Analog Comparator result enabled for fault detection
- Bit 15: RESERVED** – Unused bit
- Bit 14: PWMA\_DCOMP3\_EN** – Enables Digital Comparator 3 result for DPWM 2 PWM-A Fault Detection  
 0 = Digital Comparator 3 disabled for fault detection (Default)  
 1 = Digital Comparator 3 enabled for fault detection
- Bit 13: PWMA\_DCOMP2\_EN** – Enables Digital Comparator 2 result for DPWM 2 PWM-A Fault Detection  
 0 = Digital Comparator 2 disabled for fault detection (Default)  
 1 = Digital Comparator 2 enabled for fault detection
- Bit 12: PWMA\_DCOMP1\_EN** – Enables Digital Comparator 1 result for DPWM 2 PWM-A Fault Detection  
 0 = Digital Comparator 1 disabled for fault detection (Default)  
 1 = Digital Comparator 1 enabled for fault detection
- Bit 11: PWMA\_DCOMP0\_EN** – Enables Digital Comparator 0 result for DPWM 2 PWM-A Fault Detection  
 0 = Digital Comparator 0 disabled for fault detection (Default)  
 1 = Digital Comparator 0 enabled for fault detection
- Bit 10: PWMA\_FAULT3\_EN** – Enables FAULT[3] pin for DPWM 2 PWM-A Fault Detection  
 0 = External Fault pin disabled for fault detection (Default)  
 1 = External Fault pin enabled for fault detection
- Bit 9: PWMA\_FAULT2\_EN** – Enables FAULT[2] pin for DPWM 2 PWM-A Fault Detection  
 0 = External Fault pin disabled for fault detection (Default)  
 1 = External Fault pin enabled for fault detection
- Bit 8: PWMA\_FAULT1\_EN** – Enables FAULT[1] pin for DPWM 2 PWM-A Fault Detection  
 0 = External Fault pin disabled for fault detection (Default)  
 1 = External Fault pin enabled for fault detection
- Bit 7: PWMA\_FAULT0\_EN** – Enables FAULT[0] pin for DPWM 2 PWM-A Fault Detection  
 0 = External Fault pin disabled for fault detection (Default)  
 1 = External Fault pin enabled for fault detection
- Bit 6: PWMA\_ACOMP\_G\_EN** – Enables Analog Comparator G result for DPWM 2 PWM-A Fault detection  
 0 = Analog Comparator result disabled for fault detection (Default)  
 1 = Analog Comparator result enabled for fault detection
- Bit 5: PWMA\_ACOMP\_F\_EN** – Enables Analog Comparator F result for DPWM 2 PWM-A Fault detection  
 0 = Analog Comparator result disabled for fault detection (Default)  
 1 = Analog Comparator result enabled for fault detection
- Bit 4: PWMA\_ACOMP\_E\_EN** – Enables Analog Comparator E result for DPWM 2 PWM-A Fault detection  
 0 = Analog Comparator result disabled for fault detection (Default)  
 1 = Analog Comparator result enabled for fault detection
- Bit 3: PWMA\_ACOMP\_D\_EN** – Enables Analog Comparator D result for DPWM 2 PWM-A Fault detection  
 0 = Analog Comparator result disabled for fault detection (Default)  
 1 = Analog Comparator result enabled for fault detection
- Bit 2: PWMA\_ACOMP\_C\_EN** – Enables Analog Comparator C result for DPWM 2 PWM-A Fault detection  
 0 = Analog Comparator result disabled for fault detection (Default)  
 1 = Analog Comparator result enabled for fault detection
- Bit 1: PWMA\_ACOMP\_B\_EN** – Enables Analog Comparator B result for DPWM 2 PWM-A Fault detection  
 0 = Analog Comparator result disabled for fault detection (Default)  
 1 = Analog Comparator result enabled for fault detection
- Bit 0: PWMA\_ACOMP\_A\_EN** – Enables Analog Comparator A result for DPWM 2 PWM-A Fault detection  
 0 = Analog Comparator result disabled for fault detection (Default)

1 = Analog Comparator result enabled for fault detection

### A.2.25 DPWM 2 IDE Detection Register (DPWM2IDEDET)

Address 0x00030060

Bit Number	6	5	4	3
Bit Name	ACOMP_G_EN	ACOMP_F_EN	ACOMP_E_EN	ACOMP_D_EN
Access	R/W	R/W	R/W	R/W
Default	0	0	0	0

Bit Number	2	1	0
Bit Name	ACOMP_C_EN	ACOMP_B_EN	ACOMP_A_EN
Access	R/W	R/W	R/W
Default	0	0	0

**Bit 6: ACOMP\_6\_EN** – Enables Analog Comparator G result for DPWM 2 IDE detection  
 0 = Analog Comparator result disabled for IDE detection (Default)  
 1 = Analog Comparator result enabled for IDE detection

**Bit 5: ACOMP\_5\_EN** – Enables Analog Comparator F result for DPWM 2 IDE detection  
 0 = Analog Comparator result disabled for IDE detection (Default)  
 1 = Analog Comparator result enabled for IDE detection

**Bit 4: ACOMP\_4\_EN** – Enables Analog Comparator E result for DPWM 2 IDE detection  
 0 = Analog Comparator result disabled for IDE detection (Default)  
 1 = Analog Comparator result enabled for IDE detection

**Bit 3: ACOMP\_3\_EN** – Enables Analog Comparator D result for DPWM 2 IDE detection  
 0 = Analog Comparator result disabled for IDE detection (Default)  
 1 = Analog Comparator result enabled for IDE detection

**Bit 2: ACOMP\_2\_EN** – Enables Analog Comparator C result for DPWM 2 IDE detection  
 0 = Analog Comparator result disabled for IDE detection (Default)  
 1 = Analog Comparator result enabled for IDE detection

**Bit 1: ACOMP\_1\_EN** – Enables Analog Comparator B result for DPWM 2 IDE detection  
 0 = Analog Comparator result disabled for IDE detection (Default)  
 1 = Analog Comparator result enabled for IDE detection

**Bit 0: ACOMP\_0\_EN** – Enables Analog Comparator A result for DPWM 2 IDE detection  
 0 = Analog Comparator result disabled for IDE detection (Default)  
 1 = Analog Comparator result enabled for IDE detection



**A.2.26 DPWM 3 Current Limit Control Register (DPWM3CLIM)**

Address 0x00030064

Bit Number	16	15	14
Bit Name	ANALOG_PCM_EN	DCOMP3_EN	DCOMP2_EN
Access	R/W	R/W	R/W
Default	0	0	0

Bit Number	13	12	11	10	9
Bit Name	DCOMP1_EN	DCOMP0_EN	RESERVED	FAULT3_EN	FAULT2_EN
Access	R/W	R/W	R	R/W	R/W
Default	0	0	0	0	0

Bit Number	8	7	6	5	4
Bit Name	FAULT1_EN	FAULT0_EN	ACOMP_G_EN	ACOMP_F_EN	ACOMP_E_EN
Access	R/W	R/W	R/W	R/W	R/W
Default	0	0	0	0	0

Bit Number	3	2	1	0
Bit Name	ACOMP_D_EN	ACOMP_C_EN	ACOMP_B_EN	ACOMP_A_EN
Access	R/W	R/W	R/W	R/W
Default	0	0	0	0

**Bit 16: ANALOG\_PCM\_EN** – Enables Analog Peak Current detection result for DPWM 2 Current Limit

0 = Analog Peak Current detection disabled for current limit (Default)

1 = Analog Peak Current detection enabled for current limit

**Bit 15: DCOMP3\_EN** – Enables Digital Comparator 3 result for DPWM 3 Current Limit

0 = Digital Comparator 3 result disabled for current limit (Default)

1 = Digital Comparator 3 result enabled for current limit

**Bit 14: DCOMP2\_EN** – Enables Digital Comparator 2 result for DPWM 3 Current Limit

0 = Digital Comparator 2 result disabled for current limit (Default)

1 = Digital Comparator 2 result enabled for current limit

**Bit 13: DCOMP1\_EN** – Enables Digital Comparator 1 result for DPWM 3 Current Limit

0 = Digital Comparator 1 result disabled for current limit (Default)

1 = Digital Comparator 1 result enabled for current limit

**Bit 12: DCOMP0\_EN** – Enables Digital Comparator 0 result for DPWM 3 Current Limit

0 = Digital Comparator 0 result disabled for current limit (Default)

1 = Digital Comparator 0 result enabled for current limit

**Bit 11: RESERVED** – Unused Bit

**Bit 10: FAULT3\_EN** – Enables FAULT[3] pin for DPWM 3 Current Limit

0 = External Fault pin disabled for current limit (Default)

1 = External Fault pin enabled for current limit

**Bit 9: FAULT2\_EN** – Enables FAULT[2] pin for DPWM 3 Current Limit

0 = External Fault pin disabled for current limit (Default)

1 = External Fault pin enabled for current limit

**Bit 8: FAULT1\_EN** – Enables FAULT[1] pin for DPWM 3 Current Limit

0 = External Fault pin disabled for current limit (Default)

1 = External Fault pin enabled for current limit

**Bit 7: FAULT0\_EN** – Enables FAULT[0] pin for DPWM 3 Current Limit

0 = External Fault pin disabled for current limit (Default)

1 = External Fault pin enabled for current limit

**Bit 6: ACOMP\_G\_EN** – Enables Analog Comparator G result for DPWM 3 Current Limit

0 = Analog Comparator result disabled for current limit (Default)

1 = Analog Comparator result enabled for current limit

**Bit 5: ACOMP\_F\_EN** – Enables Analog Comparator F result for DPWM 3 Current Limit

0 = Analog Comparator result disabled for current limit (Default)

1 = Analog Comparator result enabled for current limit

**Bit 4: ACOMP\_E\_EN** – Enables Analog Comparator E result for DPWM 3 Current Limit

0 = Analog Comparator result disabled for current limit (Default)

1 = Analog Comparator result enabled for current limit

**Bit 3: ACOMP\_D\_EN** – Enables Analog Comparator D result for DPWM 3 Current Limit

0 = Analog Comparator result disabled for current limit (Default)

1 = Analog Comparator result enabled for current limit

**Bit 2: ACOMP\_C\_EN** – Enables Analog Comparator C result for DPWM 3 Current Limit

0 = Analog Comparator result disabled for current limit (Default)

1 = Analog Comparator result enabled for current limit

**Bit 1: ACOMP\_B\_EN** – Enables Analog Comparator B result for DPWM 3 Current Limit

0 = Analog Comparator result disabled for current limit (Default)

1 = Analog Comparator result enabled for current limit

**Bit 0: ACOMP\_A\_EN** – Enables Analog Comparator A result for DPWM 3 Current Limit

0 = Analog Comparator result disabled for current limit (Default)

1 = Analog Comparator result enabled for current limit

**A.2.27 DPWM 3 Fault AB Detection Register (DPWM3FLTABDET)**
**Address 0x00030068**

Bit Number	14	13	12	11	10
Bit Name	DCOMP3_EN	DCOMP2_EN	DCOMP1_EN	DCOMP0_EN	FAULT3_EN
Access	R/W	R/W	R/W	R/W	R/W
Default	0	0	0	0	0

Bit Number	9	8	7	6	5
Bit Name	FAULT2_EN	FAULT1_EN	FAULT0_EN	ACOMP_G_EN	ACOMP_F_EN
Access	R/W	R/W	R/W	R/W	R/W
Default	0	0	0	0	0

Bit Number	4	3	2	1	0
Bit Name	ACOMP_E_EN	ACOMP_D_EN	ACOMP_C_EN	ACOMP_B_EN	ACOMP_A_EN
Access	R/W	R/W	R/W	R/W	R/W
Default	0	0	0	0	0

- Bit 14: DCOMP3\_EN** – Enables Digital Comparator 3 result for DPWM 3 Fault AB Detection  
0 = Digital Comparator 3 disabled for Fault AB detection (Default)  
1 = Digital Comparator 3 enabled for Fault AB detection
- Bit 13: DCOMP2\_EN** – Enables Digital Comparator 2 result for DPWM 3 Fault AB Detection  
0 = Digital Comparator 2 disabled for Fault AB detection (Default)  
1 = Digital Comparator 2 enabled for Fault AB detection
- Bit 12: DCOMP1\_EN** – Enables Digital Comparator 1 result for DPWM 3 Fault AB Detection  
0 = Digital Comparator 1 disabled for Fault AB detection (Default)  
1 = Digital Comparator 1 enabled for Fault AB detection
- Bit 11: DCOMP0\_EN** – Enables Digital Comparator 0 result for DPWM 3 Fault AB Detection  
0 = Digital Comparator 0 disabled for Fault AB detection (Default)  
1 = Digital Comparator 0 enabled for Fault AB detection
- Bit 10: FAULT3\_EN** – Enables FAULT[3] pin for DPWM 3 Fault AB detection  
0 = External Fault pin disabled for Fault AB detection (Default)  
1 = External Fault pin enabled for Fault AB detection
- Bit 9: FAULT2\_EN** – Enables FAULT[2] pin for DPWM 3 Fault AB detection  
0 = External Fault pin disabled for Fault AB detection (Default)  
1 = External Fault pin enabled for Fault AB detection
- Bit 8: FAULT1\_EN** – Enables FAULT[1] pin for DPWM 3 Fault AB detection  
0 = External Fault pin disabled for Fault AB detection (Default)  
1 = External Fault pin enabled for Fault AB detection
- Bit 7: FAULT0\_EN** – Enables FAULT[0] pin for DPWM 3 Fault AB detection  
0 = External Fault pin disabled for Fault AB detection (Default)  
1 = External Fault pin enabled for Fault AB detection
- Bit 6: ACOMP\_G\_EN** – Enables Analog Comparator G result for DPWM 3 Fault AB detection  
0 = Analog Comparator result disabled for Fault AB detection (Default)  
1 = Analog Comparator result enabled for Fault AB detection
- Bit 5: ACOMP\_F\_EN** – Enables Analog Comparator F result for DPWM 3 Fault AB detection  
0 = Analog Comparator result disabled for Fault AB detection (Default)  
1 = Analog Comparator result enabled for Fault AB detection
- Bit 4: ACOMP\_E\_EN** – Enables Analog Comparator E result for DPWM 3 Fault AB detection  
0 = Analog Comparator result disabled for Fault AB detection (Default)

- 1 = Analog Comparator result enabled for Fault AB detection
- Bit 3: ACOMP\_D\_EN** – Enables Analog Comparator D result for DPWM 3 Fault AB detection  
0 = Analog Comparator result disabled for Fault AB detection (Default)
- 1 = Analog Comparator result enabled for Fault AB detection
- Bit 2: ACOMP\_C\_EN** – Enables Analog Comparator C result for DPWM 3 Fault AB detection  
0 = Analog Comparator result disabled for Fault AB detection (Default)
- 1 = Analog Comparator result enabled for Fault AB detection
- Bit 1: ACOMP\_B\_EN** – Enables Analog Comparator B result for DPWM 3 Fault AB detection  
0 = Analog Comparator result disabled for Fault AB detection (Default)
- 1 = Analog Comparator result enabled for Fault AB detection
- Bit 0: ACOMP\_A\_EN** – Enables Analog Comparator A result for DPWM 3 Fault AB detection  
0 = Analog Comparator result disabled for Fault AB detection (Default)  
1 = Analog Comparator result enabled for Fault AB detection

**A.2.28 DPWM 3 Fault Detection Register (DPWM3FAULTDET)**

Address 0x0003006C

Bit Number	30	29	28
Bit Name	PWMB_DCOMP3_EN	PWMB_DCOMP2_EN	PWMB_DCOMP1_EN
Access	R/W	R/W	R/W
Default	0	0	0

Bit Number	27	26	25
Bit Name	PWMB_DCOMP0_EN	PWMB_FAULT3_EN	PWMB_FAULT2_EN
Access	R/W	R/W	R/W
Default	0	0	0

Bit Number	24	23	22
Bit Name	PWMB_FAULT1_EN	PWMB_FAULT0_EN	PWMB_ACOMP_G_EN
Access	R/W	R/W	R/W
Default	0	0	0

Bit Number	21	20	19
Bit Name	PWMB_ACOMP_F_EN	PWMB_ACOMP_E_EN	PWMB_ACOMP_D_EN
Access	R/W	R/W	R/W
Default	0	0	0

Bit Number	18	17	16
Bit Name	PWMB_ACOMP_C_EN	PWMB_ACOMP_B_EN	PWMB_ACOMP_A_EN
Access	R/W	R/W	R/W
Default	0	0	0

Bit Number	15	14
Bit Name	RESERVED	PWMA_DCOMP3_EN
Access	-	R/W
Default	0	0

Bit Number	13	12	11
Bit Name	PWMA_DCOMP2_EN	PWMA_DCOMP1_EN	PWMA_DCOMP0_EN
Access	R/W	R/W	R/W
Default	0	0	0

Bit Number	10	9
Bit Name	PWMA_FAULT3_EN	PWMA_FAULT2_EN
Access	R/W	R/W
Default	0	0

Bit Number	8	7	6
Bit Name	PWMA_FAULT1_EN	PWMA_FAULT0_EN	PWMA_ACOMP_G_EN
Access	R/W	R/W	R/W
Default	0	0	0

Bit Number	5	4	3
Bit Name	PWMA_ACOMP_F_EN	PWMA_ACOMP_E_EN	PWMA_ACOMP_D_EN
Access	R/W	R/W	R/W
Default	0	0	0

Bit Number	2	1	0
Bit Name	PWMA_ACOMP_C_EN	PWMA_ACOMP_B_EN	PWMA_ACOMP_A_EN
Access	R/W	R/W	R/W
Default	0	0	0

- Bit 30: PWMB\_DCOMP3\_EN** – Enables Digital Comparator 3 result for DPWM 3 PWM-B Fault Detection  
0 = Digital Comparator 3 disabled for fault detection (Default)  
1 = Digital Comparator 3 enabled for fault detection
- Bit 29: PWMB\_DCOMP2\_EN** – Enables Digital Comparator 2 result for DPWM 3 PWM-B Fault Detection  
0 = Digital Comparator 2 disabled for fault detection (Default)  
1 = Digital Comparator 2 enabled for fault detection
- Bit 28: PWMB\_DCOMP1\_EN** – Enables Digital Comparator 1 result for DPWM 3 PWM-B Fault Detection  
0 = Digital Comparator 1 disabled for fault detection (Default)  
1 = Digital Comparator 1 enabled for fault detection
- Bit 27: PWMB\_DCOMP0\_EN** – Enables Digital Comparator 0 result for DPWM 3 PWM-B Fault Detection  
0 = Digital Comparator 0 disabled for fault detection (Default)  
1 = Digital Comparator 0 enabled for fault detection
- Bit 26: PWMB\_FAULT3\_EN** – Enables FAULT[3] pin for DPWM 3 PWM-B Fault Detection  
0 = External Fault pin disabled for fault detection (Default)  
1 = External Fault pin enabled for fault detection
- Bit 25: PWMB\_FAULT2\_EN** – Enables FAULT[2] pin for DPWM 3 PWM-B Fault Detection  
0 = External Fault pin disabled for fault detection (Default)  
1 = External Fault pin enabled for fault detection
- Bit 24: PWMB\_FAULT1\_EN** – Enables FAULT[1] pin for DPWM 3 PWM-B Fault Detection  
0 = External Fault pin disabled for fault detection (Default)  
1 = External Fault pin enabled for fault detection
- Bit 23: PWMB\_FAULT0\_EN** – Enables FAULT[0] pin for DPWM 3 PWM-B Fault Detection  
0 = External Fault pin disabled for fault detection (Default)  
1 = External Fault pin enabled for fault detection
- Bit 22: PWMB\_ACOMP\_G\_EN** – Enables Analog Comparator G result for DPWM 3 PWM-B Fault detection  
0 = Analog Comparator result disabled for fault detection (Default)  
1 = Analog Comparator result enabled for fault detection
- Bit 21: PWMB\_ACOMP\_F\_EN** – Enables Analog Comparator F result for DPWM 3 PWM-B Fault detection  
0 = Analog Comparator result disabled for fault detection (Default)  
1 = Analog Comparator result enabled for fault detection
- Bit 20: PWMB\_ACOMP\_E\_EN** – Enables Analog Comparator E result for DPWM 3 PWM-B Fault detection  
0 = Analog Comparator result disabled for fault detection (Default)  
1 = Analog Comparator result enabled for fault detection
- Bit 19: PWMB\_ACOMP\_D\_EN** – Enables Analog Comparator D result for DPWM 3 PWM-B Fault detection  
0 = Analog Comparator result disabled for fault detection (Default)  
1 = Analog Comparator result enabled for fault detection

- Bit 18: PWMB\_ACOMP\_C\_EN** – Enables Analog Comparator C result for DPWM 3 PWM-B Fault detection  
 0 = Analog Comparator result disabled for fault detection (Default)  
 1 = Analog Comparator result enabled for fault detection
- Bit 17: PWMB\_ACOMP\_B\_EN** – Enables Analog Comparator B result for DPWM 3 PWM-B Fault detection  
 0 = Analog Comparator result disabled for fault detection (Default)  
 1 = Analog Comparator result enabled for fault detection
- Bit 16: PWMB\_ACOMP\_A\_EN** – Enables Analog Comparator A result for DPWM 3 PWM-B Fault detection  
 0 = Analog Comparator result disabled for fault detection (Default)  
 1 = Analog Comparator result enabled for fault detection
- Bit 15: RESERVED** – Unused bit
- Bit 14: PWMA\_DCOMP3\_EN** – Enables Digital Comparator 3 result for DPWM 3 PWM-A Fault Detection  
 0 = Digital Comparator 3 disabled for fault detection (Default)  
 1 = Digital Comparator 3 enabled for fault detection
- Bit 13: PWMA\_DCOMP2\_EN** – Enables Digital Comparator 2 result for DPWM 3 PWM-A Fault Detection  
 0 = Digital Comparator 2 disabled for fault detection (Default)  
 1 = Digital Comparator 2 enabled for fault detection
- Bit 12: PWMA\_DCOMP1\_EN** – Enables Digital Comparator 1 result for DPWM 3 PWM-A Fault Detection  
 0 = Digital Comparator 1 disabled for fault detection (Default)  
 1 = Digital Comparator 1 enabled for fault detection
- Bit 11: PWMA\_DCOMP0\_EN** – Enables Digital Comparator 0 result for DPWM 3 PWM-A Fault Detection  
 0 = Digital Comparator 0 disabled for fault detection (Default)  
 1 = Digital Comparator 0 enabled for fault detection
- Bit 10: PWMA\_FAULT3\_EN** – Enables FAULT[3] pin for DPWM 3 PWM-A Fault Detection  
 0 = External Fault pin disabled for fault detection (Default)  
 1 = External Fault pin enabled for fault detection
- Bit 9: PWMA\_FAULT2\_EN** – Enables FAULT[2] pin for DPWM 3 PWM-A Fault Detection  
 0 = External Fault pin disabled for fault detection (Default)  
 1 = External Fault pin enabled for fault detection
- Bit 8: PWMA\_FAULT1\_EN** – Enables FAULT[1] pin for DPWM 3 PWM-A Fault Detection  
 0 = External Fault pin disabled for fault detection (Default)  
 1 = External Fault pin enabled for fault detection
- Bit 7: PWMA\_FAULT0\_EN** – Enables FAULT[0] pin for DPWM 3 PWM-A Fault Detection  
 0 = External Fault pin disabled for fault detection (Default)  
 1 = External Fault pin enabled for fault detection
- Bit 6: PWMA\_ACOMP\_G\_EN** – Enables Analog Comparator G result for DPWM 3 PWM-A Fault detection  
 0 = Analog Comparator result disabled for fault detection (Default)  
 1 = Analog Comparator result enabled for fault detection
- Bit 5: PWMA\_ACOMP\_F\_EN** – Enables Analog Comparator F result for DPWM 3 PWM-A Fault detection  
 0 = Analog Comparator result disabled for fault detection (Default)  
 1 = Analog Comparator result enabled for fault detection
- Bit 4: PWMA\_ACOMP\_E\_EN** – Enables Analog Comparator E result for DPWM 3 PWM-A Fault detection  
 0 = Analog Comparator result disabled for fault detection (Default)  
 1 = Analog Comparator result enabled for fault detection
- Bit 3: PWMA\_ACOMP\_D\_EN** – Enables Analog Comparator D result for DPWM 3 PWM-A Fault detection  
 0 = Analog Comparator result disabled for fault detection (Default)  
 1 = Analog Comparator result enabled for fault detection
- Bit 2: PWMA\_ACOMP\_C\_EN** – Enables Analog Comparator C result for DPWM 3 PWM-A Fault detection  
 0 = Analog Comparator result disabled for fault detection (Default)  
 1 = Analog Comparator result enabled for fault detection
- Bit 1: PWMA\_ACOMP\_B\_EN** – Enables Analog Comparator B result for DPWM 3 PWM-A Fault detection  
 0 = Analog Comparator result disabled for fault detection (Default)  
 1 = Analog Comparator result enabled for fault detection
- Bit 0: PWMA\_ACOMP\_A\_EN** – Enables Analog Comparator A result for DPWM 3 PWM-A Fault detection  
 0 = Analog Comparator result disabled for fault detection (Default)

---

1 = Analog Comparator result enabled for fault detection



**A.2.29 DPWM 3 IDE Detection Register (DPWM3IDEDET)**

Address 0x00030070

Bit Number	6	5	4	3
Bit Name	ACOMP_G_EN	ACOMP_F_EN	ACOMP_E_EN	ACOMP_D_EN
Access	R/W	R/W	R/W	R/W
Default	0	0	0	0

Bit Number	2	1	0
Bit Name	ACOMP_C_EN	ACOMP_B_EN	ACOMP_A_EN
Access	R/W	R/W	R/W
Default	0	0	0

**Bit 6: ACOMP\_6\_EN** – Enables Analog Comparator G result for DPWM 3 IDE detection  
 0 = Analog Comparator result disabled for IDE detection (Default)  
 1 = Analog Comparator result enabled for IDE detection

**Bit 5: ACOMP\_5\_EN** – Enables Analog Comparator F result for DPWM 3 IDE detection  
 0 = Analog Comparator result disabled for IDE detection (Default)  
 1 = Analog Comparator result enabled for IDE detection

**Bit 4: ACOMP\_4\_EN** – Enables Analog Comparator E result for DPWM 3 IDE detection  
 0 = Analog Comparator result disabled for IDE detection (Default)  
 1 = Analog Comparator result enabled for IDE detection

**Bit 3: ACOMP\_3\_EN** – Enables Analog Comparator D result for DPWM 3 IDE detection  
 0 = Analog Comparator result disabled for IDE detection (Default)  
 1 = Analog Comparator result enabled for IDE detection

**Bit 2: ACOMP\_2\_EN** – Enables Analog Comparator C result for DPWM 3 IDE detection  
 0 = Analog Comparator result disabled for IDE detection (Default)  
 1 = Analog Comparator result enabled for IDE detection

**Bit 1: ACOMP\_1\_EN** – Enables Analog Comparator B result for DPWM 3 IDE detection  
 0 = Analog Comparator result disabled for IDE detection (Default)  
 1 = Analog Comparator result enabled for IDE detection

**Bit 0: ACOMP\_0\_EN** – Enables Analog Comparator A result for DPWM 3 IDE detection  
 0 = Analog Comparator result disabled for IDE detection (Default)  
 1 = Analog Comparator result enabled for IDE detection

**A.2.30 HFO Fail Detect Register (HFOFAILDET)**

Address 0x00030074

Bit Number	17:1	0
Bit Name	HFO_FAIL_THRESH	HFO_DETECT_EN
Access	R/W	R/W
Default	0_0000_0000_1111_1111	0

**Bits 17-1: HFO\_FAIL\_THRESH** – Configures threshold where a clear flag is used to clear a counter in the Low Frequency Oscillator domain (if LFO counter overflows, a reset will be generated), resolution of threshold equals High Frequency Oscillator period

**Bit 0: HFO\_DETECT\_EN** – Enables High Frequency Oscillator Failure Detection logic, device will be reset upon

detection of an oscillator failure

0 = Disables High Frequency Oscillator Failure Detection (Default)

1 = Enables High Frequency Oscillator Failure Detection

### **A.2.31 LFO Fail Detect Register (LFOFAILDET)**

**Address 0x00030078**

<b>Bit Number</b>	<b>6:2</b>	<b>1</b>	<b>0</b>
<b>Bit Name</b>	LFO_FAIL_THRESH	LFO_FAIL_INT_EN	LFO_DETECT_EN
<b>Access</b>	R/W	R/W	R/W
<b>Default</b>	0_0011	0	0

**Bits 6-2: LFO\_FAIL\_THRESH** – Configures threshold where a clear flag is used to clear a counter in the High Frequency Oscillator domain (if HFO counter overflows, a reset will be generated), resolution of threshold equals Low Frequency Oscillator period

**Bit 1: LFO\_FAIL\_INT\_EN** – Low Frequency Oscillator Fail Interrupt Enable

0 = Disables Interrupt Generation upon LFO Failure Detection (Default)

1 = Enables Interrupt Generation upon LFO Failure Detection

**Bit 0: LFO\_DETECT\_EN** – Enables Low Frequency Oscillator Failure Detection logic, interrupt will be generated upon detection of an oscillator failure

0 = Disables Low Frequency Oscillator Failure Detection (Default)

1 = Enables Low Frequency Oscillator Failure Detection

**A.2.32 IDE Control Register (IDCTRL)**

Address 0003007C

Bit Number	31:24	23:16
Bit Name	DCM_LIMIT_H	DCM_LIMIT_L
Access	R/W	R/W
Default	0000_0000	0000_0000

Bit Number	15:14	13	12:0
Bit Name	RESERVED	DCM_INT_EN	IDE_KD
Access	-	R/W	R/W
Default	00	0	0_0000_0000_0000

**Bits 31-24: DCM\_LIMIT\_H** – Value added to 1-Da value to provide hysteresis for exiting DCM mode

**Bits 23-16: DCM\_LIMIT\_L** – Value subtracted from 1-Da value to provide hysteresis for entering DCM mode

**Bit 15-14: RESERVED** – Unused Bits

**Bit 13: DCM\_INT\_EN** – Enables Discontinuous Conduction Mode (DCM) interrupt generation based on selected Filter outputs

0 = Disables DCM Detection Interrupt (Default)

1 = Enables DCM Detection Interrupt

**Bits 12-0: IDE\_KD** – 13-bit unsigned value used to calculate the DPWM B Pulse width when configured in IDE Mode. IDE\_KD is configured in 4.9 format, with the integer portion of the KD value ranging from 0 to 15 and 9 fractional bits available for the pulse width calculation.

## A.3 UART Registers

### A.3.1 UART Control Register 0 (UARTCTRL0)

Address FFF7EC00 – UART 0 Control Register 0

Address FFF7ED00 – UART 1 Control Register 0

Bit Number	7	6	5
Bit Name	STOP	PARITY	PARITY_ENA
Access	R/W	R/W	R/W
Default	0	0	0

Bit Number	4	3	2:0
Bit Name	SYNC_MODE	ADDR_MODE	DATA_SIZE
Access	R/W	R/W	R/W
Default	0	0	000

**Bit 7: STOP** – Configures stop bits for each frame  
 0 = One STOP bit included in each frame (Default)  
 1 = Two STOP bits included in each frame

**Bit 6: PARITY** – Sets odd or even parity  
 0 = Odd parity (Default)  
 1 = Even parity

**Bit 5: PARITY\_ENA** - Enables parity transmission  
 0 = No parity bit included in each frame (Default)  
 1 = One parity bit included in each frame

**Bit 4: SYNC\_MODE** – Selects between Synchronous mode and Asynchronous mode  
 0 = Synchronous (Default)  
 1 = Asynchronous

**Bit 3: ADDR\_MODE** – Selects between Idle and Address Bit Mode  
 0 = IDLE Line mode with no Address bit (Default)  
 1 = Address Bit mode with one Address bit

**Bits 2-0: DATA\_SIZE** – Determines the TX and RX byte size  
 000 = 1 bit of data (Default)  
 001 = 2 bit of data  
 010 = 3 bits of data  
 011 = 4 bits of data  
 100 = 5 bits of data  
 101 = 6 bits of data  
 110 = 7 bits of data  
 111 = 8 bits of data

### A.3.2 UART Receive Status Register (UARTRXST)

Address FFF7EC04 – UART 0 Receive Status Register

Address FFF7ED04 – UART 1 Receive Status Register

Bit Number	4	3	2	1	0
Bit Name	RX_IDLE	SLEEP	RX_RDY	RX_WAKE	RX_ENA
Access	R	R/W	R	R	R/W
Default	-	0	-	-	0

**Bit 4: RX\_IDLE** –RX Idle status bit

0 = Not in Rx Idle State

1 = Rx Idle detected

**Bit 3: SLEEP** – Sleep Mode Configuration

0 = Sleep Mode disabled (Default)

1 = Sleep Mode enabled

**Bit 2: RX\_RDY** – UART Receiver ready status bit

0 = UART Receiver not ready

1 = UART Receiver ready

**Bit 1: RX\_WAKE** – UART Receiver wake status bit

0 = UART Receiver has not entered wakeup state

1 = UART Receiver has entered wakeup state

**Bit 0: RX\_ENA** – Turns on UART Receiver

0 = UART Receiver disabled (Default)

1 = UART Receiver enabled

### A.3.3 UART Transmit Status Register (UARTTXST)

Address FFF7EC08 – UART 0 Transmit Status Register

Address FFF7ED08 – UART 1 Transmit Status Register

Bit Number	7	6	5:4
Bit Name	CONTINUE	LOOPBACK	RESERVED
Access	R/W	R/W	-
Default	0	0	00

Bit Number	3	2	1	0
Bit Name	TX_EMPTY	TX_RDY	TX_WAKE	TX_ENA
Access	R	R	R/W	R/W
Default	-	-	0	0

**Bit 7: CONTINUE** – Configure operation in suspend mode

0 = Stop transmitting on suspend (Default)

1 = Continue transmitting after initiation of suspend

**Bit 6: LOOPBACK** – Loopback Mode Configuration

0 = Normal mode (Default)

1 = Loopback Mode

**Bit 5-4: RESERVED** – Unused bits – Default to 00

**Bit 3: TX\_EMPTY** – Transmit buffer status

0 = Transmit buffer is not empty

1 = Transmit buffer is empty

**Bit 2: TX\_RDY** – Transmitter Ready

0 = UART Transmitter is not ready

1 = UART Transmitter is ready to transmit data

- Bit 1: TX\_WAKE** – TX wake control bit  
 0 = UART Transmitter Wakeup disabled (Default)  
 1 = UART Transmitter Wakeup enabled
- Bit 0: TX\_ENA** – Turns on TX module  
 0 = UART Transmitter Disabled (Default)  
 1 = UART Transmitter Enabled

### A.3.4 UART Control Register 3 (UARTCTRL3)

Address FFF7EC0C – UART 0 Control Register 3

Address FFF7ED0C – UART 1 Control Register 3

Bit Number	7	6	5	4
Bit Name	SW_RESET	POWERDOWN	CLOCK	RX_INT_ENA
Access	R/W	R/W	R/W	R/W
Default	0	0	0	0

Bit Number	3	2	1	0
Bit Name	TX_INT_ENA	WAKEUP_INT_ENA	BRKDT_INT_ENA	ERR_INT_ENA
Access	R/W	R/W	R/W	R/W
Default	0	0	0	0

- Bit 7: SW\_RESET** – Software reset for UART Transmitter/Receiver  
 0 = Enables Software Reset (Default)  
 1 = Disables Software Reset
- Bit 6: POWERDOWN** – Power-down Transmitter/Receiver Control  
 0 = Disables Power-down mode (Default)  
 1 = Enables Power-down mode
- Bit 5: CLOCK\_ENA** – UART Clock Select  
 0 = Selects external clock (Default)  
 1 = Selects internal clock
- Bit 4: RX\_INT\_ENA** – Enables the interrupts from UART Receiver  
 0 = Disables interrupts from UART Receiver (Default)  
 1 = Enables interrupts from UART Receiver
- Bit 3: TX\_INT\_ENA** – Enables the interrupts from UART Transmitter  
 0 = Disables interrupts from UART Transmitter (Default)  
 1 = Enables interrupts from UART Transmitter
- Bit 2: WAKEUP\_INT\_ENA** – Enables the wakeup interrupt from UART  
 0 = Disables Wakeup Interrupt (Default)  
 1 = Enables Wakeup Interrupt
- Bit 1: BRKDT\_INT\_ENA** – Enables the Broken Circuit interrupt from UART Receiver  
 0 = Disables Broken Circuit Interrupt (Default)  
 1 = Enables Broken Circuit Interrupt
- Bit 0: ERR\_INT\_ENA** – Enables UART Receiver Error Interrupt  
 0 = Disables UART Receiver Error Interrupt (Default)  
 1 = Enables UART Receiver Error Interrupt

### A.3.5 UART Interrupt Status Register (UARTINTST)

Address FFF7EC10 – UART 0 Interrupt Status Register

Address FFF7ED10 – UART 1 Interrupt Status Register

Bit Number	7	6	5	4
Bit Name	BUS_BUSY	RESERVED	FRAME_ERR	OVERRUN_ERR
Access	R	-	R	R
Default	-	0	-	-

Bit Number	3	2	1	0
Bit Name	PARITY_ERR	WAKEUP_INT	BRKDT_INT	RX_ERR
Access	R	R	R	R
Default	-	-	-	-

**Bit 7: BUS\_BUSY** – UART Receiver Busy Indicator

0 = UART Receiver ready to accept new frame

1 = UART Receiver currently processing message

**Bit 6: RESERVED** – Unused bit – Default to 0

**Bit 5: FRAME\_ERR** – UART Receiver Framing Error

0 = No framing error found within incoming data message

1 = Indicates the incoming data message had a framing error

**Bit 4: OVERRUN\_ERR** – UART Receiver Buffer Overflow

0 = No overflow condition found in receive buffer

1 = Indicates the receive buffer has overflowed

**Bit 3: PARITY\_ERR** – UART Receiver Parity Error

0 = No parity error found on the incoming data message

1 = Indicates a parity error found on the incoming data message

**Bit 2: WAKEUP\_INT** – UART Receiver Wakeup Interrupt

0 = No Wakeup Interrupt received from UART Receiver

1 = Wakeup Interrupt received from UART Receiver

**Bit 1: BRKDT\_INT** – UART Receiver Broken Circuit Interrupt

0 = No Broken Circuit interrupt received from UART Receiver

1 = Indicates a Broken Circuit interrupt received from UART Receiver

**Bit 0: RX\_ERR** – UART Receiver Error

0 = No UART Receiver Errors detected

1 = Frame Error or Overrun error or Parity Error or Broken Circuit error received from UART Receiver

### A.3.6 UART Baud Divisor High Byte Register (UARTHBAUD)

Address FFF7EC14 – UART 0 Baud Divisor High Byte Register

Address FFF7ED14 – UART 1 Baud Divisor High Byte Register

Bit Number	7:0
Bit Name	BAUD_DIV_H
Access	R/W
Default	0000_0000

Bits 7-0: BAUD\_DIV\_H - Sets the high byte of the 24 bit baud rate selector

### A.3.7 UART Baud Divisor Middle Byte Register (UARTMBAUD)

Address FFF7EC18 – UART 0 Baud Divisor Middle Byte Register

Address FFF7ED18 – UART 1 Baud Divisor Middle Byte Register

Bit Number	7:0
Bit Name	BAUD_DIV_M
Access	R/W
Default	0000_0000

Bits 7-0: BAUD\_DIV\_M - Sets the middle byte of the 24 bit baud rate selector

### A.3.8 UART Baud Divisor Low Byte Register (UARTLBAUD)

Address FFF7EC1C – UART 0 Baud Divisor Low Byte Register

Address FFF7ED1C – UART 1 Baud Divisor Low Byte Register

Bit Number	7:0
Bit Name	BAUD_DIV_L
Access	R/W
Default	0000_0000

Bits 7-0: BAUD\_DIV\_L - Sets the low byte of the 24 bit baud rate selector

### A.3.9 UART Receive Buffer (UARTRXBUF)

Address FFF7EC24 – UART 0 Receive Buffer

Address FFF7ED24 – UART 1 Receive Buffer

Bit Number	7:0
Bit Name	RXDAT
Access	R
Default	-

Bits 7-0: RXDAT – Contains the last data byte received from the UART Receiver



### A.3.10 UART Transmit Buffer (UARTTXBUF)

Address FFF7EC28 – UART 0 Transmit Buffer

Address FFF7ED28 – UART 1 Transmit Buffer

Bit Number	7:0
Bit Name	TXDAT
Access	R/W
Default	0000_0000

Bits 7-0: TXDAT – Contains the data byte to be transmitted by the UART Transmitter

### A.3.11 UART I/O Control Register (UARTIOCTRLSCLK, UARTIOCTRLRX, UARTIOCTRLTX)

Address FFF7EC2C – UART 0 I/O (SCLK) Control Register

Address FFF7ED2C – UART 1 I/O (SCLK) Control Register

Address FFF7EC30 – UART 0 I/O (RX) Control Register

Address FFF7ED30 – UART 1 I/O (RX) Control Register

Address FFF7EC34 – UART 0 I/O (TX) Control Register

Address FFF7ED34 – UART 1 I/O (TX) Control Register

Bit Number	3	2	1	0
Bit Name	DATA_IN	DATA_OUT	IO_FUNC	IO_DIR
Access	R	R/W	R/W	R/W
Default	-	0	0	0

Bit 3: DATA\_IN – Data received from pin when configured as GPIO

Bit 2: DATA\_OUT – Data transmitted to pin when configured as GPIO

Bit 1: IO\_FUNC – Selects the function for UART pins

0 = GPIO mode (Default)

1 = Baud Clock for SCLK, Normal operation for SCI\_RX/SCI\_TX

Bit 0: IO\_DIR – Pin direction when configured as GPIO

0 = Input (Default)

1 = Output

### A.3.12 UART Baud Divisor Sub Bits Register (UARTSBAUD)

Address FFF7EC38 – UART 0 Baud Divisor Sub Bits Register

Address FFF7ED38 – UART 1 Baud Divisor Sub Bits Register

Bit Number	2:0
Bit Name	BAUD_SUB
Access	R/W
Default	000

Bit 2-0: BAUD\_SUB – Each LSB adds one ICLK period to the baud period calculated via the values programmed in the UARTHBAUD, UARTMBAUD, and UARLBAUD registers.

### A.3.13 UART RX Control Register 4 (UARTRXCTRL4)

Address FFF7EC3C – UART 0 RX Control Register 4

Address FFF7ED3C – UART 1 RX Control Register 4

Bit Number	7:6	5	4:3
------------	-----	---	-----

<b>Bit Name</b>	<b>RX_CENTER_SAMPLE_EN</b>	<b>RX_CAL_CONTINUOUS_EN</b>	<b>RX_CAL_MODE_BIT_WIDTH</b>
<b>Access</b>	R/W	R/W	R/W
<b>Default</b>	00	0	00

<b>Bit Number</b>	<b>2</b>	<b>1</b>	<b>0</b>
<b>Bit Name</b>	<b>RX_CAL_MODE_EN</b>	<b>RESERVED</b>	<b>RX_SYNC_ON_START_EN</b>
<b>Access</b>	R/W	R	R/W
<b>Default</b>	0	-	0

**Bit 7-6: RX\_CENTER\_SAMPLE\_EN** – Sample position for the UART RX  
 00 = Takes 3 samples to the right of the data eye (Default)  
 01 = Takes 3 samples in the center of the data eye  
 10 = Takes 3 samples to the left of the data eye  
 11 = Reserved

**Bit 5: RX\_CAL\_CONTINUOUS\_EN** – Continuously captures baud pulses  
 0 = Baud pulses will not be captured without a low to high toggle of the RX\_CAL\_MODE\_EN bit. (Default)  
 1 = Baud pulses will continue to be captured and the updated values will be written to the UARTRX MBAUD, UARTRXLBAUD, and UARTRXSBAUD registers.

**Bit 4-3: RX\_CAL\_MODE\_BIT\_WIDTH** – Sets the maximum number of baud periods a pulse (transition on the RX line of 1->0->1 or 0->1->0) can span and still be recorded in the UARTRX MBAUD, UARTRXLBAUD, and UARTRXSBAUD registers. The CAL mode feature helps refine the baud period programmed in the UARTHBAUD, UARTMBAUD, UARTLBAUD, and UARTSBAUD registers.  
 00 = Captures a low pulse (1->0->1) that spans 1 baud period (Default)  
 01 = Captures a low pulse (1->0->1) that spans 1-4 baud periods  
 10 = Captures a low pulse (1->0->1) that spans 1-12 baud periods  
 11 = Captures a low/high pulse that spans 1 baud period

**Bit 2: RX\_CAL\_MODE\_EN** – Enables the capture feature of the UART.  
 Recorded pulses are stored in the UARTRX MBAUD, UARTRXLBAUD, and UARTRXSBAUD registers.  
 0 = Disables the capture features of the UART (Default)  
 1 = Enables the capture feature of the UART

**Bit 1: RESERVED** – Unused Bit

**Bit 0: RX\_SYNC\_ON\_START\_EN** – Enables the sync on start feature of the UART RX. Set RX\_INDEP\_BAUD\_EN to '1' and the program the UARTRX MBAUD, UARTRXLBAUD, and UARTRXSBAUD registers with the desired communication speed to utilize this feature.

0 = Start bit is detected based on the free running TX baud rate counter. (Default)  
 1 = Start bit immediately detected.

### A.3.14 UART RX Control Register 5 (UARTRXCTRL5)

Address FFF7EC40 – UART 0 RX Control Register 5

Address FFF7ED40 – UART 1 RX Control Register 5

<b>Bit Number</b>	<b>1</b>	<b>0</b>
<b>Bit Name</b>	<b>RX_OVERSAMPLE_ERR</b>	<b>RX_INDEP_BAUD_EN</b>
<b>Access</b>	R	R/W
<b>Default</b>	0	0

**Bit 1: RX\_OVERSAMPLE\_ERR** – Indicates when the 3 data samples taken in the eye of the transmission are not identical.

0 = All sampled bits are identical

1 = Sampled bits are not identical

**Bit 0: RX\_INDEP\_BAUD\_EN** – UART RX independent baud rate enabled

0 = Universal baud rate registers are used (UARTBBAUD, UARTMBAUD, and UARTLBAUD) to program both the TX and RX baud rates. One counter is used for both the TX and RX; therefore, sync on start mode must be disabled. (Default)

1 = UART RX baud rate is programmed by the UARTRX MBAUD, UARTRXLBAUD, and UARTRXSBAUD registers. UART TX baud rate is programmed by the UARTBBAUD, UARTMBAUD, UARTLBAUD, and UARTSBAUD registers. Two independent counters are used for the TX and RX; therefore, sync on start mode can be enabled.

### A.3.15 UART RX Baud Divisor Middle Byte Register (UARTRX MBAUD)

Address FFF7EC44 – UART 0 RX Baud Divisor Middle Byte Register

Address FFF7ED44 – UART 1 RX Baud Divisor Middle Byte Register

Bit Number	7:0
Bit Name	RX_M_BAUD
Access	R/W
Default	0000_0000

**Bits 7-0: RX\_M\_BAUD** – Middle byte of the 16-bit RX baud rate selector.

This is a dual purpose register.

When RX\_INDEP\_BAUD\_EN = 0 and RX\_CAL\_MODE\_EN = 1 this register is used to read the middle byte of the measured input baud pulse width.

When RX\_INDEP\_BAUD\_EN = 1 this register is used to program the middle byte of the 16-bit RX baud rate selector.

### A.3.16 UART RX Baud Divisor Low Byte Register (UARTRXLBAUD)

Address FFF7EC48 – UART 0 RX Baud Divisor Low Byte Register

Address FFF7ED48 – UART 1 RX Baud Divisor Low Byte Register

Bit Number	7:0
Bit Name	RX_L_BAUD
Access	R/W
Default	0000_0000

**Bits 7-0: RX\_L\_BAUD** – Low byte of the 16-bit RX baud rate selector.

This is a dual purpose register.

When RX\_INDEP\_BAUD\_EN = 0 and RX\_CAL\_MODE\_EN = 1 this register is used to read the low byte of the measured input baud pulse width.

When RX\_INDEP\_BAUD\_EN = 1 this register is used to program the low byte of the 16-bit RX baud rate selector.

**A.3.17 UART RX Baud Divisor Sub Bits Register (UARTRXSBAUD)**
**Address FFF7EC4C – UART 0 RX Baud Divisor Sub Bits Register**
**Address FFF7ED4C – UART 1 RX Baud Divisor Sub Bits Register**

<b>Bit Number</b>	<b>2:0</b>
<b>Bit Name</b>	<b>RX_S_BAUD</b>
<b>Access</b>	<b>R/W</b>
<b>Default</b>	<b>000</b>

**Bit 2-0: RX\_S\_BAUD** – Each LSB adds one ICLK period to the baud period calculated via the values programmed in the UARTRXMBAUD and UARTRXLBAUD registers.

This is a dual purpose register.

When RX\_INDEP\_BAUD\_EN = 0 and RX\_CAL\_MODE\_EN = 1 this register is used to read the sub bits of the measured input baud pulse width.

When RX\_INDEP\_BAUD\_EN = 1 this register is used to program the sub bits of the RX baud rate selector.

## A.4 ADC Registers

### A.4.1 ADC Control Register (ADCCTRL)

Address 00040000

Bit Number	31:24	23	22
Bit Name	EXT_TRIG_DLY	EXT_TRIG_GPIO_VAL	EXT_TRIG_GPIO_DIR
Access	R/W	R/W	R/W
Default	0000_0000	0	0

Bit Number	21	20	19:16	15:13
Bit Name	EXT_TRIG_GPIO_EN	EXT_TRIG_EN	EXT_TRIG_SEL	SAMPLING_SEL
Access	R/W	R/W	R/W	R/W
Default	0	0	0000	000

Bit Number	12	11	10:8	7:4
Bit Name	ADC_SEL_REF	ADC_ROUND	BYPASS_EN	MAX_CONV
Access	R/W	R/W	R/W	R/W
Default	0	0	111	0000

Bit Number	3	2	1	0
Bit Name	SINGLE_SWEEP	SW_START	ADC_INT_EN	ADC_EN
Access	R/W	R/W	R/W	R/W
Default	0	0	0	0

**Bits 31-24: EXT\_TRIG\_DLY** – 8-bit External ADC Trigger Delay configuration, LSB bit resolution equals period of ADC Clock (High Frequency Oscillator Frequency divided by 8)

**Bit 23: EXT\_TRIG\_GPIO\_VAL** – Output value of ADC\_EXT\_TRIG pin when configured in GPIO mode

0 = ADC\_EXT\_TRIG pin driven low (Default)

1 = ADC\_EXT\_TRIG pin driven high

**Bit 22: EXT\_TRIG\_GPIO\_DIR** – Direction of ADC\_EXT\_TRIG pin when configured in GPIO mode

0 = ADC\_EXT\_TRIG pin configured as input (Default)

1 = ADC\_EXT\_TRIG pin configured as output

**Bit 21: EXT\_TRIG\_GPIO\_EN** – Configuration of ADC\_EXT\_TRIG pin

0 = ADC\_EXT\_TRIG pin configured in functional mode (Default)

1 = ADC\_EXT\_TRIG pin configured in GPIO mode

**Bit 20: EXT\_TRIG\_EN** – External Trigger Enable, conversions are started using the external trigger as selectable by the **EXT\_TRIG\_SEL** bits.

0 = Disable External Trigger capability (Default)

1 = Enable External Trigger capability

**Bits 19-16: EXT\_TRIG\_SEL** – Selects which external trigger can start a conversion loop.

0 = HS Loop1 Event 1 (DPWMA Low Resolution Edge) (Default)

1 = HS Loop1 Event 3 (DPWMB Low Resolution Edge)

2 = HS Loop2 Event 1 (DPWMA Low Resolution Edge)

3 = HS Loop2 Event 3 (DPWMB Low Resolution Edge)

4 = HS Loop3 Event 1 (DPWMA Low Resolution Edge)

5 = HS Loop3 Event 3 (DPWMB Low Resolution Edge)

6 = HS Loop4 Event 1 (DPWMA Low Resolution Edge)

- 7 = HS Loop4 Event 3 (DPWMB Low Resolution Edge)
- 8 = ADC\_EXT\_TRIG pin
- 9 = Analog Comparator A Output
- A = Analog Comparator B Output
- B = Analog Comparator C Output
- C = Analog Comparator D Output
- D = Analog Comparator E Output
- E = Analog Comparator F Output
- F = Analog Comparator G Output

**Bits 15-13: ADC\_SAMPLING\_SEL** - Defines ADC sampling and hold timing setup, refer to ADC Specification for details on timing options

- 111 = 539KS/s
- 110 = 267KS/s
- 101 = 530KS/s
- 100 = 267KS/s
- 011 = 504KS/s
- 010 = 453KS/s
- 001 = 422KS/s
- 000 = 267KS/s (Default)

**Bit 12: ADC\_SEL\_REF** – ADC Voltage Reference Select  
 0 = Selects Internal ADC voltage reference (Default)  
 1 = Selects AVDD as ADC voltage reference

**Bit 11: ADC\_ROUND** – Enables rounding of ADC Result to 10 bits  
 0 = ADC Results are not rounded (Default)  
 1 = ADC Results are rounded to 10 most significant bits

**Bits 10-8: BYPASS\_EN** – Enables dual sample/hold for specific channels. There are only four valid settings:  
 011 = Dual Sample/Hold enabling on Channel 2  
 101 = Dual Sample/Hold enabling on Channel 1  
 110 = Dual Sample/Hold enabling on Channel 0  
 111 = Dual Sample/Hold Disabled (Default)

**Bits 7-4: MAX\_CONV** – Maximum number of conversion done in one conversion loop  
 0x0 = 1 conversion selection converted in the loop (Default)  
 0xF = All 16 conversion selections converted in the loop

**Bit 3: SINGLE\_SWEEP** – ADC Conversion Mode  
 0 = Continuous conversion loop runs (Default)  
 1 = Single conversion loop run

**Bit 2: SW\_START** - Firmware ADC Conversion Start, bit will be cleared automatically by hardware at end of ADC conversion  
 0 = Conversions not initiated by firmware (Default)  
 1 = Initiate an ADC conversion loop

**Bit 1: ADC\_INT\_EN** – End-of-conversion Interrupt Enable  
 0 = Disable End-of-Conversion Interrupt (Default)  
 1 = Enable End-of-Conversion Interrupt

**Bit 0: ADC\_EN** – ADC12 Enable Control  
 0 = Disables ADC (Default)  
 1 = Enables ADC

#### A.4.2 ADC Status Register (ADCSTAT)

Address 00040004

Bit Number	6:3	2	1	0
Bit Name	CURRENT_CH	ADC_EXT_TRIG_VAL	ADC_INT_RAW	ADC_INT
Access	R	R	R	R
Default	-	-	-	-

**Bits 6-3: CURRENT\_CH** – Register shows the currently converting channel

**Bit 2: ADC\_EXT\_TRIG\_VAL** – ADC\_EXT\_TRIG pin value

0 = ADC\_EXT\_TRIG pin driven low

1 = ADC\_EXT\_TRIG pin driven high

**Bit 1: ADC\_INT\_RAW** – End-of-conversion interrupt flag, raw version

0 = No End-of-conversion interrupt detected

1 = End-of-conversion interrupt found

**Bit 0: ADC\_INT** – End-of-conversion interrupt flag, latched version

0 = No End-of-conversion interrupt detected

1 = End-of-conversion interrupt found

#### A.4.3 ADC Test Control Register (ADCTSTCTRL)

Address 00040008

Bit Number	1	0
Bit Name	ADC_SH_BUFFER_EN	RESERVED
Access	R/W	
Default	0	0

**Bit 1: ADC\_SH\_BUFFER\_EN** - ADC Sample and Hold Buffer Enable

0 = Disables ADC SH Buffer (Default)

1 = Enables ADC SH Buffer

**Bit 0: RESERVED** – Unused bit

#### A.4.4 ADC Sequence Select Register 0 (ADCSEQSEL0)

Address 0004000C

Bit Number	28	27:24	23:21	20	19:16
Bit Name	SEQ3_SH	SEQ3	RESERVED	SEQ2_SH	SEQ2
Access	R/W	R/W	-	R/W	R/W
Default	0	0000	000	0	0000

Bit Number	15:13	12	11:8	7:5	4	3:0
Bit Name	RESERVED	SEQ1_SH	SEQ1	RESERVED	SEQ0_SH	SEQ0
Access	-	R/W	R/W	-	R/W	R/W
Default	000	0	0000	000	0	0000

**Bit 28: SEQ3\_SH** – Dual channel sequence select

0 = Not selected for Dual Sampling (Default)

1 = Selected for Dual Sampling

**Bits 27-24: SEQ3** - Channel to be converted fourth

0000 = Channel 0 selected (Default)

0001 = Channel 1 selected

.....

1111 = Channel 15 selected

**Bits 23-21: RESERVED** – Unused bits

**Bit 20: SEQ2\_SH** – Dual channel sequence select

0 = Not selected for Dual Sampling (Default)

1 = Selected for Dual Sampling

**Bits 19-16: SEQ2** - Channel to be converted third

0000 = Channel 0 selected (Default)

0001 = Channel 1 selected  
 .....  
 1111 = Channel 15 selected  
**Bits 15-13: RESERVED** – Unused bits  
**Bit 12: SEQ1\_SH** – Dual channel sequence select  
 0 = Not selected for Dual Sampling (Default)  
 1 = Selected for Dual Sampling  
**Bits 11-8: SEQ1** - Channel to be converted second  
 0000 = Channel 0 selected (Default)  
 0001 = Channel 1 selected  
 .....  
 1111 = Channel 15 selected  
**Bits 7-5: RESERVED** – Unused bits  
**Bit 4: SEQ0\_SH** – Dual channel sequence select  
 0 = Not selected for Dual Sampling (Default)  
 1 = Selected for Dual Sampling  
**Bits 3-0: SEQ0** - Channel to be converted first  
 0000 = Channel 0 selected (Default)  
 0001 = Channel 1 selected  
 .....  
 1111 = Channel 15 selected

#### A.4.5 ADC Sequence Select Register 1 (ADCSEQSEL1)

Address 00040010

Bit Number	28	27:24	23:21	20	19:16
Bit Name	SEQ7_SH	SEQ7	RESERVED	SEQ6_SH	SEQ6
Access	R/W	R/W	-	R/W	R/W
Default	0	0000	000	0	0000

Bit Number	15:13	12	11:8	7:5	4	3:0
Bit Name	RESERVED	SEQ5_SH	SEQ5	RESERVED	SEQ4_SH	SEQ4
Access	-	R/W	R/W	-	R/W	R/W
Default	000	0	0000	000	0	0000

**Bit 28 SEQ7\_SH** – Dual channel sequence select  
 0 = Not selected for Dual Sampling (Default)  
 1 = Selected for Dual Sampling  
**Bits 27-24: SEQ7**- Channel to be converted eighth  
 0000 = Channel 0 selected (Default)  
 0001 = Channel 1 selected  
 .....  
 1111 = Channel 15 selected  
**Bits 23-21: RESERVED** – Unused bits  
**Bit 20: SEQ6\_SH** – Dual channel sequence select  
 0 = Not selected for Dual Sampling (Default)  
 1 = Selected for Dual Sampling  
**Bits 19-16: SEQ6** - Channel to be converted seventh  
 0000 = Channel 0 selected (Default)  
 0001 = Channel 1 selected  
 .....  
 1111 = Channel 15 selected



**Bits 15-13: RESERVED** – Unused bits

**Bit 12: SEQ5\_SH** – Dual channel sequence select  
 0 = Not selected for Dual Sampling (Default)  
 1 = Selected for Dual Sampling

**Bits 11-8: SEQ5** - Channel to be converted sixth  
 0000 = Channel 0 selected (Default)  
 0001 = Channel 1 selected  
 .....  
 1111 = Channel 15 selected

**Bits 7-5: RESERVED** – Unused bits

**Bit 4: SEQ4\_SH** – Dual channel sequence select  
 0 = Not selected for Dual Sampling (Default)  
 1 = Selected for Dual Sampling

**Bits 3-0: SEQ4** - Channel to be converted fifth  
 0000 = Channel 0 selected (Default)  
 0001 = Channel 1 selected  
 .....  
 1111 = Channel 15 selected

#### **A.4.6 ADC Sequence Select Register 2 (ADCSEQSEL2)**

**Address 00040014**

Bit Number	28	27:24	23:21	20	19:16
Bit Name	SEQ11_SH	SEQ11	RESERVED	SEQ10_SH	SEQ10
Access	R/W	R/W	-	R/W	R/W
Default	0	0000	000	0	0000

Bit Number	15:13	12	11:8	7:5	4	3:0
Bit Name	RESERVED	SEQ9_SH	SEQ9	RESERVED	SEQ8_SH	SEQ8
Access	-	R/W	R/W	-	R/W	R/W
Default	000	0	0000	000	0	00000

**Bit 28: SEQ11\_SH** – Dual channel sequence select  
 0 = Not selected for Dual Sampling (Default)  
 1 = Selected for Dual Sampling

**Bits 27-24: SEQ11** - Channel to be converted twelfth  
 0000 = Channel 0 selected (Default)  
 0001 = Channel 1 selected  
 .....  
 1111 = Channel 15 selected

**Bits 23-21: RESERVED** – Unused bits

**Bit 20: SEQ10\_SH** – Dual channel sequence select  
 0 = Not selected for Dual Sampling (Default)  
 1 = Selected for Dual Sampling

**Bits 19-16: SEQ10** - Channel to be converted eleventh  
 0000 = Channel 0 selected (Default)  
 0001 = Channel 1 selected  
 .....  
 1111 = Channel 15 selected

**Bits 15-13: RESERVED** – Unused bits

**Bit 12: SEQ9\_SH** – Dual channel sequence select  
 0 = Not selected for Dual Sampling (Default)

- 1 = Selected for Dual Sampling
- Bits 11-8: SEQ9** - Channel to be converted tenth  
 0000 = Channel 0 selected (Default)  
 0001 = Channel 1 selected  
 .....  
 1111 = Channel 15 selected
- Bits 7-5: RESERVED** – Unused bits
- Bit 4: SEQ8\_SH** – Dual channel sequence select  
 0 = Not selected for Dual Sampling (Default)  
 1 = Selected for Dual Sampling
- Bits 3-0: SEQ8** - Channel to be converted ninth  
 0000 = Channel 0 selected (Default)  
 0001 = Channel 1 selected  
 .....  
 1111 = Channel 15 selected

#### A.4.7 ADC Sequence Select Register 3 (ADCSEQSEL3)

Address 00040018

Bit Number	28	27:24	23:21	20	19:16
Bit Name	SEQ15_SH	SEQ15	RESERVED	SEQ14_SH	SEQ14
Access	R/W	R/W	-	R/W	R/W
Default	0	0000	000	0	0000

Bit Number	15:13	12	11:8	7:5	4	3:0
Bit Name	RESERVED	SEQ13_SH	SEQ13	RESERVED	SEQ12_SH	SEQ12
Access	-	R/W	R/W	-	R/W	R/W
Default	000	0	0000	000	0	0000

- Bit 28: SEQ15\_SH** – Dual channel sequence select  
 0 = Not selected for Dual Sampling (Default)  
 1 = Selected for Dual Sampling
- Bits 27-24: SEQ15** - Channel to be converted sixteenth  
 0000 = Channel 0 selected (Default)  
 0001 = Channel 1 selected  
 .....  
 1111 = Channel 15 selected
- Bits 23-21: RESERVED** – Unused bits
- Bit 20: SEQ14\_SH** – Dual channel sequence select  
 0 = Not selected for Dual Sampling (Default)  
 1 = Selected for Dual Sampling
- Bits 19-16: SEQ14** - Channel to be converted fifteenth  
 0000 = Channel 0 selected (Default)  
 0001 = Channel 1 selected  
 .....  
 1111 = Channel 15 selected
- Bits 15-13: RESERVED** – Unused bits
- Bit 12: SEQ13\_SH** – Dual channel sequence select  
 0 = Not selected for Dual Sampling (Default)  
 1 = Selected for Dual Sampling
- Bits 11-8: SEQ13** - Channel to be converted fourteenth  
 0000 = Channel 0 selected (Default)

0001 = Channel 1 selected

.....

1111 = Channel 15 selected

**Bits 7-5: RESERVED** – Unused bits

**Bit 4: SEQ12\_SH** – Dual channel sequence select

0 = Not selected for Dual Sampling (Default)

1 = Selected for Dual Sampling

**Bits 3-0: SEQ12** - Channel to be converted thirteenth

0000 = Channel 0 selected (Default)

0001 = Channel 1 selected

.....

1111 = Channel 15 selected

#### A.4.8 ADC Result Registers 0-15 (ADCRESULT<sub>x</sub>, x=0:15)

Address 0004001C – ADC Result Register 0

Address 00040020 – ADC Result Register 1

Address 00040024 – ADC Result Register 2

Address 00040028 – ADC Result Register 3

Address 0004002C – ADC Result Register 4

Address 00040030 – ADC Result Register 5

Address 00040034 – ADC Result Register 6

Address 00040038 – ADC Result Register 7

Address 0004003C – ADC Result Register 8

Address 00040040 – ADC Result Register 9

Address 00040044 – ADC Result Register 10

Address 00040048 – ADC Result Register 11

Address 0004004C – ADC Result Register 12

Address 00040050 – ADC Result Register 13

Address 00040054 – ADC Result Register 14

Address 00040058 – ADC Result Register 15

Bit Number	11:0
Bit Name	RESULT
Access	R
Default	-

Bits 11-0: RESULT – Each sequence has a dedicated result register.

#### A.4.9 ADC Averaged Result Registers 0-5 (ADCAVGRESULT<sub>x</sub>, x=0:15)

Address 0004005C – ADC Averaged Result Register 0

Address 00040060 – ADC Averaged Result Register 1

Address 00040064 – ADC Averaged Result Register 2

Address 00040068 – ADC Averaged Result Register 3

Address 0004006C – ADC Averaged Result Register 4

Address 00040070 – ADC Averaged Result Register 5

Bit Number	11:0
Bit Name	RESULT
Access	R
Default	-

Bits 11-0: RESULT – First 6 ADC Results have an averaged result

**A.4.10 ADC Digital Compare Limits Register 0-5 (ADCCOMPLIMx, x=0:5)**

**Address 00040074 – ADC Digital Compare Limits Register 0**

**Address 00040078 – ADC Digital Compare Limits Register 1**

**Address 0004007C – ADC Digital Compare Limits Register 2**

**Address 00040080 – ADC Digital Compare Limits Register 3**

**Address 00040084 – ADC Digital Compare Limits Register 4**

**Address 00040088 – ADC Digital Compare Limits Register 5**

Bit Number	27:16	15:12	11:0
Bit Name	UPPER_LIMIT	RESERVED	LOWER_LIMIT
Access	R/W	-	R/W
Default	1111_1111_1111	0000	0000_0000_0000

**Bits 27-16: UPPER\_LIMIT** – Configures the upper limit value. Results of comparison can be read from the ADC Digital Compare Results Register (see Section 6.12).

**Bits 15-12: RESERVED** – Unused bits – Default to 0000

**Bits 11-0: LOWER\_LIMIT** – Configures the lower limit value. Results of comparison can be read from the ADC Digital Compare Results Register (see Section 6.12).

#### A.4.11 ADC Digital Compare Enable Register (ADCCOMPEN)

Address 0004008C

Bit Number	27	26	25	24
Bit Name	COMP5_UP_INT_EN	COMP5_LO_INT_EN	COMP4_UP_INT_EN	COMP4_LO_INT_EN
Access	R/W	R/W	R/W	R/W
Default	0	0	0	0

Bit Number	23	22	21	20
Bit Name	COMP3_UP_INT_EN	COMP3_LO_INT_EN	COMP2_UP_INT_EN	COMP2_LO_INT_EN
Access	R/W	R/W	R/W	R/W
Default	0	0	0	0

Bit Number	19	18	17	16
Bit Name	COMP1_UP_INT_EN	COMP1_LO_INT_EN	COMP0_UP_INT_EN	COMP0_LO_INT_EN
Access	R/W	R/W	R/W	R/W
Default	0	0	0	0

Bit Number	15:14	13	12	11
Bit Name	RESERVED	COMP5_DATA_SEL	COMP4_DATA_SEL	COMP3_DATA_SEL
Access	-	R/W	R/W	R/W
Default	00	0	0	0

Bit Number	10	9	8	7:6
Bit Name	COMP2_DATA_SEL	COMP1_DATA_SEL	COMP0_DATA_SEL	RESERVED
Access	R/W	R/W	R/W	-
Default	0	0	0	00

Bit Number	5	4	3	2	1	0
Bit Name	COMP5_EN	COMP4_EN	COMP3_EN	COMP2_EN	COMP1_EN	COMP0_EN
Access	R/W	R/W	R/W	R/W	R/W	R/W
Default	0	0	0	0	0	0

**Bit 27: COMP5\_UP\_INT\_EN** – Digital Comparator 5 Upper Limit Interrupt Enable

0 = Interrupt generation disabled on result above upper limit (Default)

1 = Interrupt generation enabled on result above upper limit

**Bit 26: COMP5\_LO\_INT\_EN** – Digital Comparator 5 Lower Limit Interrupt Enable

0 = Interrupt generation disabled on result below lower limit (Default)

1 = Interrupt generation enabled on result below lower limit

**Bit 25: COMP4\_UP\_INT\_EN** – Digital Comparator 4 Upper Limit Interrupt Enable

0 = Interrupt generation disabled on result above upper limit (Default)

1 = Interrupt generation enabled on result above upper limit

**Bit 24: COMP4\_LO\_INT\_EN** – Digital Comparator 4 Lower Limit Interrupt Enable

0 = Interrupt generation disabled on result below lower limit (Default)

1 = Interrupt generation enabled on result below lower limit

**Bit 23: COMP3\_UP\_INT\_EN** – Digital Comparator 3 Upper Limit Interrupt Enable

0 = Interrupt generation disabled on result above upper limit (Default)

- 1 = Interrupt generation enabled on result above upper limit
- Bit 22: COMP3\_LO\_INT\_EN** – Digital Comparator 3 Lower Limit Interrupt Enable  
 0 = Interrupt generation disabled on result below lower limit (Default)  
 1 = Interrupt generation enabled on result below lower limit
- Bit 21: COMP2\_UP\_INT\_EN** – Digital Comparator 2 Upper Limit Interrupt Enable  
 0 = Interrupt generation disabled on result above upper limit (Default)  
 1 = Interrupt generation enabled on result above upper limit
- Bit 20: COMP2\_LO\_INT\_EN** – Digital Comparator 2 Lower Limit Interrupt Enable  
 0 = Interrupt generation disabled on result below lower limit (Default)  
 1 = Interrupt generation enabled on result below lower limit
- Bit 19: COMP1\_UP\_INT\_EN** – Digital Comparator 1 Upper Limit Interrupt Enable  
 0 = Interrupt generation disabled on result above upper limit (Default)  
 1 = Interrupt generation enabled on result above upper limit
- Bit 18: COMP1\_LO\_INT\_EN** – Digital Comparator 1 Lower Limit Interrupt Enable  
 0 = Interrupt generation disabled on result below lower limit (Default)  
 1 = Interrupt generation enabled on result below lower limit
- Bit 17: COMP0\_UP\_INT\_EN** – Digital Comparator 0 Upper Limit Interrupt Enable  
 0 = Interrupt generation disabled on result above upper limit (Default)  
 1 = Interrupt generation enabled on result above upper limit
- Bit 16: COMP0\_LO\_INT\_EN** – Digital Comparator 0 Lower Limit Interrupt Enable  
 0 = Interrupt generation disabled on result below lower limit (Default)  
 1 = Interrupt generation enabled on result below lower limit
- Bits 15-14: RESERVED** – Unused bits
- Bit 13: COMP5\_DATA\_SEL** – Digital Comparator 5 Data Select  
 0 = Raw ADC Result 5 used for comparison (Default)  
 1 = Averaged ADC Result 5 used for comparison
- Bit 12: COMP4\_DATA\_SEL** – Digital Comparator 4 Data Select  
 0 = Raw ADC Result 4 used for comparison (Default)  
 1 = Averaged ADC Result 4 used for comparison
- Bit 11: COMP3\_DATA\_SEL** – Digital Comparator 3 Data Select  
 0 = Raw ADC Result 3 used for comparison (Default)  
 1 = Averaged ADC Result 3 used for comparison
- Bit 10: COMP2\_DATA\_SEL** – Digital Comparator 2 Data Select  
 0 = Raw ADC Result 2 used for comparison (Default)  
 1 = Averaged ADC Result 2 used for comparison
- Bit 9: COMP1\_DATA\_SEL** – Digital Comparator 1 Data Select  
 0 = Raw ADC Result 1 used for comparison (Default)  
 1 = Averaged ADC Result 1 used for comparison
- Bit 8: COMP0\_DATA\_SEL** – Digital Comparator 0 Data Select  
 0 = Raw ADC Result 0 used for comparison (Default)  
 1 = Averaged ADC Result 0 used for comparison
- Bits 7-6: RESERVED** – Unused bits
- Bit 5: COMP5\_EN** – Digital Comparator 5 Enable  
 0 = Comparator Disabled (Default)  
 1 = Comparator Enabled
- Bit 4: COMP4\_EN** – Digital Comparator 4 Enable  
 0 = Comparator Disabled (Default)  
 1 = Comparator Enabled
- Bit 3: COMP3\_EN** – Digital Comparator 3 Enable  
 0 = Comparator Disabled (Default)  
 1 = Comparator Enabled
- Bit 2: COMP2\_EN** – Digital Comparator 2 Enable  
 0 = Comparator Disabled (Default)  
 1 = Comparator Enabled

- Bit 1: COMP1\_EN** – Digital Comparator 1 Enable  
0 = Comparator Disabled (Default)  
1 = Digital Comparator 1 Enabled
- Bit 0: COMP0\_EN** – Digital Comparator 0 Enable  
0 = Comparator Disabled (Default)  
1 = Comparator Enabled



**A.4.12 ADC Digital Compare Results Register (ADCCOMPRESULT)**

Address 00040090

Bit Number	27	26	25	24
Bit Name	DCOMP5_UP_RAW	DCOMP5_LO_RAW	DCOMP4_UP_RAW	DCOMP4_LO_RAW
Access	R	R	R	R
Default	-	-	-	-

Bit Number	23	22	21	20
Bit Name	DCOMP3_UP_RAW	DCOMP3_LO_RAW	DCOMP2_UP_RAW	DCOMP2_LO_RAW
Access	R	R	R	R
Default	-	-	-	-

Bit Number	19	18	17	16
Bit Name	DCOMP1_UP_RAW	DCOMP1_LO_RAW	DCOMP0_UP_RAW	DCOMP0_LO_RAW
Access	R	R	R	R
Default	-	-	-	-

Bit Number	15:12	11	10	9
Bit Name	RESERVED	DCOMP5_UP_INT	DCOMP5_LO_INT	DCOMP4_UP_INT
Access	-	R	R	R
Default	0000	-	-	-

Bit Number	8	7	6	5
Bit Name	DCOMP4_LO_INT	DCOMP3_UP_INT	DCOMP3_LO_INT	DCOMP2_UP_INT
Access	R	R	R	R
Default	-	-	-	-

Bit Number	4	3	2	1
Bit Name	DCOMP2_LO_INT	DCOMP1_UP_INT	DCOMP1_LO_INT	DCOMP0_UP_INT
Access	R	R	R	R
Default	-	-	-	-

Bit Number	0
Bit Name	DCOMP0_LO_INT
Access	R
Default	-

**Bit 27: DCOMP5\_UP\_RAW** – Digital Comparator 5 Upper Limit Raw Result

0 = Limit not exceeded

1 = Limit exceeded

**Bit 26: DCOMP5\_LO\_RAW** – Digital Comparator 5 Lower Limit Raw Result

0 = Limit not exceeded

1 = Limit exceeded

**Bit 25: DCOMP4\_UP\_RAW** – Digital Comparator 4 Upper Limit Raw Result

0 = Limit not exceeded

- 1 = Limit exceeded
- Bit 24: DCOMP4\_LO\_RAW** – Digital Comparator 4 Lower Limit Raw Result  
0 = Limit not exceeded  
1 = Limit exceeded
- Bit 23: DCOMP3\_UP\_RAW** – Digital Comparator 3 Upper Limit Raw Result  
0 = Limit not exceeded  
1 = Limit exceeded
- Bit 22: DCOMP3\_LO\_RAW** – Digital Comparator 3 Lower Limit Raw Result  
0 = Limit not exceeded  
1 = Limit exceeded
- Bit 21: DCOMP2\_UP\_RAW** – Digital Comparator 2 Upper Limit Raw Result  
0 = Limit not exceeded  
1 = Limit exceeded
- Bit 20: DCOMP2\_LO\_RAW** – Digital Comparator 2 Lower Limit Raw Result  
0 = Limit not exceeded  
1 = Limit exceeded
- Bit 19: DCOMP1\_UP\_RAW** – Digital Comparator 1 Upper Limit Raw Result  
0 = Limit not exceeded  
1 = Limit exceeded
- Bit 18: DCOMP1\_LO\_RAW** – Digital Comparator 1 Lower Limit Raw Result  
0 = Limit not exceeded  
1 = Limit exceeded
- Bit 17: DCOMP0\_UP\_RAW** – Digital Comparator 0 Upper Limit Raw Result  
0 = Limit not exceeded  
1 = Limit exceeded
- Bit 16: DCOMP0\_LO\_RAW** – Digital Comparator 0 Lower Limit Raw Result  
0 = Limit not exceeded  
1 = Limit exceeded
- Bits 15-12: RESERVED** – Unused bits
- Bit 11: DCOMP5\_UP\_INT** – Digital Comparator 5 Upper Limit Interrupt Result, cleared on read  
0 = Limit not exceeded  
1 = Limit exceeded
- Bit 10: DCOMP5\_LO\_INT** – Digital Comparator 5 Lower Limit Interrupt Result, cleared on read  
0 = Limit not exceeded  
1 = Limit exceeded
- Bit 9: DCOMP4\_UP\_INT** – Digital Comparator 4 Upper Limit Interrupt Result, cleared on read  
0 = Limit not exceeded  
1 = Limit exceeded
- Bit 8: DCOMP4\_LO\_INT** – Digital Comparator 4 Lower Limit Interrupt Result, cleared on read  
0 = Limit not exceeded  
1 = Limit exceeded
- Bit 7: DCOMP3\_UP\_INT** – Digital Comparator 3 Upper Limit Interrupt Result, cleared on read  
0 = Limit not exceeded  
1 = Limit exceeded
- Bit 6: DCOMP3\_LO\_INT** – Digital Comparator 3 Lower Limit Interrupt Result, cleared on read  
0 = Limit not exceeded  
1 = Limit exceeded
- Bit 5: DCOMP2\_UP\_INT** – Digital Comparator 2 Upper Limit Interrupt Result, cleared on read  
0 = Limit not exceeded  
1 = Limit exceeded
- Bit 4: DCOMP2\_LO\_INT** – Digital Comparator 2 Lower Limit Interrupt Result, cleared on read  
0 = Limit not exceeded  
1 = Limit exceeded
- Bit 3: DCOMP1\_UP\_INT** – Digital Comparator 1 Upper Limit Interrupt Result, cleared on read

0 = Limit not exceeded

1 = Limit exceeded

**Bit 2: DCOMP1\_LO\_INT** – Digital Comparator 1 Lower Limit Interrupt Result, cleared on read

0 = Limit not exceeded

1 = Limit exceeded

**Bit 1: DCOMP0\_UP\_INT** – Digital Comparator 0 Upper Limit Interrupt Result, cleared on read

0 = Limit not exceeded

1 = Limit exceeded

**Bit 0: DCOMP0\_LO\_INT** – Digital Comparator 0 Lower Limit Interrupt Result, cleared on read

0 = Limit not exceeded

1 = Limit exceeded

### A.4.13 ADC Averaging Control Register (ADCAVGCTRL)

Address 00040094

Bit Number	22:21	20	19	18:17	16
Bit Name	AVG5_CONFIG	AVG5_EN	RESERVED	AVG4_CONFIG	AVG4_EN
Access	R/W	R/W	-	R/W	R/W
Default	00	0	0	00	0

Bit Number	15	14:13	12	11
Bit Name	RESERVED	AVG3_CONFIG	AVG3_EN	RESERVED
Access	-	R/W	R/W	-
Default	0	00	0	0

Bit Number	10:9	8	7	6:5
Bit Name	AVG2_CONFIG	AVG2_EN	RESERVED	AVG1_CONFIG
Access	R/W	R/W	-	R/W
Default	00	0	0	00

Bit Number	4	3	2:1	0
Bit Name	AVG1_EN	RESERVED	AVG0_CONFIG	AVG0_EN
Access	R/W	-	R/W	R/W
Default	0	0	00	0

**Bits 22-21: AVG5\_CONFIG** – ADC Averaging Module 5 Configuration

- 0 = Moving average of 4 samples (Default)
- 1 = Moving average of 8 samples
- 2 = Moving average of 16 samples
- 3 = Moving average of 32 samples

**Bit 20: AVG5\_EN** – ADC Averaging Module 5 Enable

- 0 = ADC Averaging Disabled (Default)
- 1 = ADC Averaging Enabled

**Bit 19: RESERVED** – Unused bit

**Bits 18-17: AVG4\_CONFIG** – ADC Averaging Module 4 Configuration

- 0 = Moving average of 4 samples (Default)
- 1 = Moving average of 8 samples
- 2 = Moving average of 16 samples
- 3 = Moving average of 32 samples

**Bit 16: AVG4\_EN** – ADC Averaging Module 4 Enable

- 0 = ADC Averaging Disabled (Default)
- 1 = ADC Averaging Enabled

**Bit 15: RESERVED** – Unused bit

**Bits 14-13: AVG3\_CONFIG** – ADC Averaging Module 3 Configuration

- 0 = Moving average of 4 samples (Default)
- 1 = Moving average of 8 samples
- 2 = Moving average of 16 samples
- 3 = Moving average of 32 samples

**Bit 12: AVG3\_EN** – ADC Averaging Module 3 Enable

- 0 = ADC Averaging Disabled (Default)
- 1 = ADC Averaging Enabled

**Bit 11: RESERVED** – Unused bit

**Bits 10-9: AVG2\_CONFIG** – ADC Averaging Module 2 Configuration

- 0 = Moving average of 4 samples (Default)
- 1 = Moving average of 8 samples
- 2 = Moving average of 16 samples
- 3 = Moving average of 32 samples

**Bit 8: AVG2\_EN** – ADC Averaging Module 4 Enable

- 0 = ADC Averaging Disabled (Default)
- 1 = ADC Averaging Enabled

**Bit 7: RESERVED** – Unused bit

**Bits 6-5: AVG1\_CONFIG** – ADC Averaging Module 1 Configuration

- 0 = Moving average of 4 samples (Default)
- 1 = Moving average of 8 samples
- 2 = Moving average of 16 samples
- 3 = Moving average of 32 samples

**Bit 4: AVG1\_EN** – ADC Averaging Module 1 Enable

- 0 = ADC Averaging Disabled (Default)
- 1 = ADC Averaging Enabled

**Bit 3: RESERVED** – Unused bit

**Bits 2-1: AVG0\_CONFIG** – ADC Averaging Module 0 Configuration

- 0 = Moving average of 4 samples (Default)
- 1 = Moving average of 8 samples
- 2 = Moving average of 16 samples
- 3 = Moving average of 32 samples

**Bit 0: AVG0\_EN** – ADC Averaging Module 0 Enable

- 0 = ADC Averaging Disabled (Default)
- 1 = ADC Averaging Enabled

## A.5 DPWM 0-3 Registers

### A.5.1 DPWM Control Register 0 (DPWMCTRL0)

Address 00050000 – DPWM 3 Control Register 0

Address 00070000 – DPWM 2 Control Register 0

Address 000A0000 – DPWM 1 Control Register 0

Address 000D0000 – DPWM 0 Control Register 0

Bit Number	31:28
Bit Name	PWM_B_INTRA_MUX
Access	R/W
Default	0000

Bit Number	27:26	23
Bit Name	PWM_A_INTRA_MUX	CBC_PWM_C_EN
Access	R/W	R/W
Default	0000	0

Bit Number	22:21	20	19
Bit Name	RESERVED	CBC_PWM_AB_EN	CBC_ADV_CNT_EN
Access	R	R/W	R/W
Default	0	0	0

Bit Number	18:17	16	15
Bit Name	MIN_DUTY_MODE	RESERVED	MSYNC_SLAVE_EN
Access	R/W	R	R/W
Default	00	0	0

Bit Number	14	13
Bit Name	D_ENABLE	RESERVED
Access	R/W	R
Default	0	0

Bit Number	12	11	10
Bit Name	RESON_MODE_FIXED_DUTY_EN	PWM_B_FLT_POL	PWM_A_FLT_POL
Access	R/W	R/W	R/W
Default	0	0	0

Bit Number	9	8	6:4
Bit Name	BLANK_B_EN	BLANK_A_EN	PWM_MODE
Access	R/W	R/W	R/W
Default	0	0	010

Bit Number	3	2	1	0
------------	---	---	---	---

Bit Name	PWM_B_INV	PWM_A_INV	CLA_EN	PWM_EN
Access	R/W	R/W	R/W	R/W
Default	0	0	1	0

**Bits 31-28: PWM\_B\_INTRA\_MUX** – Interchanges signals post edge generation

- 0 = Pass-through (Default)
- 1 = Edge-gen output, this module
- 2 = PWM-C, this module
- 3 = Crossover, this module
- 4 = Pass-through below A
- 5 = Pass-through below B
- 6 = Pass-through below C
- 7 = Pass-through below level-2 C
- 8 = Pass-through below level-3 C

**Bits 27-24: PWM\_A\_INTRA\_MUX** – Combines signals prior to HR module

- 0 = Pass-through (Default)
- 1 = Edge-gen output, this module
- 2 = PWM-C, this module
- 3 = Crossover, this module
- 4 = Pass-through below A
- 5 = Pass-through below B
- 6 = Pass-through below C
- 7 = Pass-through below level-2 C
- 8 = Pass-through below level-3 C

**Bit 23: CBC\_PWM\_C\_EN** – Set if Fault CBC changes PWM-C output

- 0 = PWM-C unaffected by Fault CBC (Default)
- 1 = PWM-C affected by Fault CBC

**Bits 22-21: RESERVED** – Unused Bits

**Bit 20: CBC\_PWM\_AB\_EN** – Set if Fault CBC changes output waveform for PWM-A and PWM-B

- 0 = PWM-A and PWM-B unaffected by Fault CBC (Default)
- 1 = PWM-A and PWM-B affected by Fault CBC

**Bit 19: CBC\_ADV\_CNT\_EN** – Selects cycle-by-cycle of operation

**Normal Mode**

- 0 = CBC disabled (Default)
- 1 = CBC enabled

**Multi and Resonant Modes**

- 0 = PWM-A and PWM-B operate independently (Default)
- 1 = PWM-A and PWM-B pulse matching enabled

**Bits 18-17: MIN\_DUTY\_MODE** – Minimum Duty Cycle Mode

- 00 = Suppression of minimum duty cycles is disabled (Default)
- 01 = CLA value is clamped to zero when below input value is less than MIN\_DUTY\_LOW
- 10 = CLA value is clamped to MIN\_DUTY\_LOW register value when input value is less than MIN\_DUTY\_LOW

**Bit 16: RESERVED** – Unused Bit

**Bit 15: MSYNC\_SLAVE\_EN** – Multi-Sync Slave Mode Control

- 0 = PWM not synchronized to another PWM channel (Default)
- 1 = Enable Multi-Sync Slave Mode, current channel will be slaved from corresponding channel

**Bit 14: D\_ENABLE** – Converts CLA duty value to DPWM as period-CLA duty value

- 0 = Value used for event calculations if CLA Duty (Default)
- 1 = Value used for event calculations is period minus CLA duty value

**Bit 13: RESERVED** – Unused Bit

**Bit 12: RESON\_MODE\_FIXED\_DUTY\_EN** – Configures how duty cycle is controlled in Resonance Mode

- 0 = Resonant mode duty cycle set by Filter duty (Default)

1 = Resonant mode duty cycle set by Auto Switch High Register

**Bit 11: PWM\_B\_FLT\_POL** – Sets the fault output polarity during a disable condition (i.e. fault or module disabled)

0 = PWM B fault output polarity is set to low (Default)

1 = PWM B fault output polarity is set to high

**Bit 10: PWM\_A\_FLT\_POL** – Sets the fault output polarity during a disable condition (i.e. fault or module disabled)

0 = PWM A fault output polarity is set to low (Default)

1 = PWM A fault output polarity is set to high

**Bit 9: BLANK\_B\_EN** – Comparator Blanking Window B Enable

0 = Comparator Blanking Window for PWM-B Disabled (Default)

1 = Comparator Blanking Window for PWM-B Enabled

**Bit 8: BLANK\_A\_EN** – Comparator Blanking Window A Enable

0 = Comparator Blanking Window for PWM-A Disabled (Default)

1 = Comparator Blanking Window for PWM-B Enabled

**Bits 7-4: PWM\_MODE** – DPWM Mode

0 = Normal Mode

1 = Resonant Mode

2 = Multi-Output Mode

3 = Triangular Mode

4 = Leading Mode

**Bit 3: PWM\_B\_INV** – PWM B Output Polarity Control

0 = Non-inverted PWM B output (Default)

1 = Inverts PWM B output

**Bit 2: PWM\_A\_INV** – PWM A Output Polarity Control

0 = Non-inverted PWM A output (Default)

1 = Inverted PWM A output

**Bit 1: CLA\_EN** – CLA Processing Enable

0 = Generate PWM waveforms from PWM Register values (Default)

1 = Enable CLA input

**Bit 0: PWM\_EN** – PWM Processing Enable

0 = Disable PWM module, outputs zero (Default)

1 = Enable PWM operation



**A.5.2 DPWM Control Register 1 (DPWMCTRL1)**

Address 00050004 – DPWM 3 Control Register 1

Address 00070004 – DPWM 2 Control Register 1

Address 000A0004 – DPWM 1 Control Register 1

Address 000D0004 – DPWM 0 Control Register 1

Bit Number	31	30	29	28
Bit Name	PRESET_EN	SYNC_FET_EN	BURST_EN	CLA_DUTY_ADJ_EN
Access	R/W	R/W	R/W	R/W
Default	0	0	0	0

Bit Number	27:24	23:21	20	19
Bit Name	SYNC_OUT_DIV_SEL	CLA_SCALE	EXT_SYNC_EN	CBC_BSIDE_ACTIVE EN
Access	R/W	R/W	R/W	R/W
Default	0000	000	0	0

Bit Number	18	17	16	15	14
Bit Name	AUTO_MODE_SEL	RESERVED	EVENT_UP_SEL	CHECK_OVERRIDE	GLOBAL PERIOD EN
Access	R/W	R	R/W	R/W	R/W
Default	0	0	01	1	0

Bit Number	13	12	11	10	9
Bit Name	PWM_B_OE	PWM_A_OE	GPIO_B_VAL	GPIO_B_EN	GPIO_A_VAL
Access	R/W	R/W	R/W	R/W	R/W
Default	0	0	0	0	0

Bit Number	8	7	6	5
Bit Name	GPIO_A_EN	PWM_HR_MULTI_OUT_EN	SFRAME_EN	PWM_B_PROT_DIS
Access	R/W	R/W	R/W	R/W
Default	0	0	0	0

Bit Number	4	3:2	1	0
Bit Name	PWM_A_PROT_DIS	HIRES_SCALE	RESERVED	HIRES_DIS
Access	R/W	R/W	R	R/W
Default	0	00	0	0

**Bit 31: PRESET\_EN** – Counter Preset Enable

0 = Counter reset to 0 upon detection of sync (Default)

1 = Counter preset to Preset Count Value upon detection of sync

**Bit 30: SYNC\_FET\_EN** – SyncFET Mode Enabled

0 = SyncFET Mode Disabled (Default)

1 = SyncFET Mode Enabled (Default)

**Bit 29: BURST\_EN** – Burst (Light Load) Mode Detection Enable

0 = Burst Mode (Light Load) Detection disabled (Default)

1 = Burst Mode (Light Load) Detection enabled

**Bit 28: CLA\_DUTY\_ADJ\_EN** – Enables CLA Duty Adjust from Current/Flux Balancing

0 = CLA Duty Adjust not enabled (Default)

1 = CLA Duty Adjust enabled

**Bits 27-24: SYNC\_OUT\_DIV\_SEL** – Sets the divider for generating the Sync Out pulse.

0000 = Sync Out generated on every switching cycle (Default)

0001 = Sync Out generated once every 2 switching cycles

0010 = Sync Out generated once every 3 switching cycles

.....

1111 = Sync Out generated once every 16 switching cycles

**Bits 23-21: CLA\_SCALE** – Scaling for CLA Input Data

000 = CLA Value (Default)

001 = CLA Value multiplied by 2

010 = CLA Value divided by 2

011 = CLA Value multiplied by 4

100 = CLA Value divided by 4

101 = CLA Value multiplied by 8

110 = CLA Value divided by 8

111 = CLA Value

**Bit 20: EXT\_SYNC\_EN** – Slave DPWM to external sync

0 = DPWM not synchronized to external sync (Default)

1 = Slave DPWM to external sync

**Bit 19: CBC\_BSIDE\_ACTIVE\_EN** – Sets if CBC responds to Fault CBC when PWM-B is active, only available in Multi and Reson modes

0 = Response to Fault CBC when PWM-A active (Default)

1 = Response to Fault CBC when PWM-A or PWM-B active

**Bit 18: AUTO\_MODE\_SEL** – Auto Switching Mode Select

0 = Auto Switching Mode disabled (Default)

1 = Auto Switching Mode enabled

**Bits 17: RESERVED** – Unused Bit

**Bits 16: EVENT\_UP\_SEL** – Update End Period Mode

0 = Events update at any time (for development purposes only)

1 = Events update at the end of the period (recommended)

**Bit 15: CHECK\_OVERRIDE** – PWM Check Override

0 = DPWM checks mathematical settings within module, correct placement of Event settings/period settings. Invalid configurations are not allowed. (Default)

1 = Overrides checking for invalid configurations and turns off PWM mathematical checking functions

**Bit 14: GLOBAL\_PERIOD\_EN**

0 = Event calculations use DPWM Period register (Default)

1 = Event calculations use Global Period register

**Bit 13: PWM\_B\_OE** – Direction for PWM B pin

0 = PWM B configured as output (Default)

1 = PWM B configured as input

**Bit 12: PWM\_A\_OE** – Direction for PWM A pin

0 = PWM A configured as output (Default)

1 = PWM A configured as input

**Bit 11: GPIO\_B\_VAL** – Sets value of PWM B output in GPIO mode

0 = PWM B driven low in GPIO mode (Default)

1 = PWM B driven high in GPIO mode

**Bit 10: GPIO\_B\_EN** – Enables GPIO mode for PWM B output

0 = PWM B in DPWM mode (Default)

1 = PWM B in GPIO mode

**Bit 9: GPIO\_A\_VAL** – Sets value of PWM A output in GPIO mode

0 = PWM A driven low in GPIO mode (Default)

1 = PWM A driven high in GPIO mode

**Bit 8: GPIO\_A\_EN** – Enables GPIO mode for PWM A output

0 = PWM A in DPWM mode (Default)

1 = PWM A in GPIO mode

**Bit 7: PWM\_HR\_MULT\_OUT\_EN** – Control bit for Hi-Res Block

0 = Disabled (Default)

1 = Enabled

**Bit 6: SFRAME\_EN** – PWM Single Step Frame Mode Enable

0 = Disable Single Frame Mode (Default)

1 = Enable Single Step Frame Mode. One EADC sample is requested, CLA then Filters, then one PWM duty cycle performed, then wait on Single Frame Trigger toggle before advancing to next frame.

**Bit 5: PWM\_B\_PROT\_DIS** – PWM B Asynchronous Protection Disable

0 = Allows asynchronous protection to turn off PWM B Output (Default)

1 = Disables asynchronous protection from turning off PWM B Output

**Bit 4: PWM\_A\_PROT\_DIS** – PWM A Asynchronous Protection Disable

0 = Allows asynchronous protection to turn off PWM A Output (Default)

1 = Disables asynchronous protection from turning off PWM A Output

**Bits 3-2: HIRES\_SCALE** – Determines resolution of high resolution steps

00 = Resolution of 16 phases. Full resolution enabled. Resolution step = PCLK/16 (Default)

11 = Resolution of 2 phases. Resolution step = PCLK/2

10 = Resolution of 4 phases. Resolution step = PCLK/4

01 = Resolution of 8 phases. Resolution step = PCLK/8

00 = Resolution of 16 phases. Full Resolution enabled.

Resolution step = PCLK/16

**Bit 1: RESERVED** – Unused Bit

**Bit 0: HIRES\_DIS** – PWM High Resolution Disable

0 = Enable High Resolution logic (Default)

1 = Disable High Resolution logic

**A.5.3 DPWM Control Register 2 (DPWMCTRL2)**

Address 00050008 – DPWM 3 Control Register 2

Address 00070008 – DPWM 2 Control Register 2

Address 000A0008 – DPWM 1 Control Register 2

Address 000D0008 – DPWM 0 Control Register 2

Bit Number	19:18	17	16
Bit Name	DTC_MODE	DTC_EN	BLANK_PCM_EN
Access	R/W	R/W	R/W
Default	00	0	0

Bit Number	15:12	11:10
Bit Name	SYNC_IN_DIV_RATIO	RESERVED
Access	R/W	R
Default	0000	0

Bit Number	9:8	7	6
Bit Name	FILTER_DUTY_SEL	IDE_DUTY_B_EN	IDE_DETECT_EN
Access	R/W	R/W	R/W
Default	00	0	0

Bit Number	5:4	3:2
Bit Name	SAMPLE_TRIG_1_OVERSAMPLE	SAMPLE_TRIG_1_MODE
Access	R/W	R/W
Default	00	00

Bit Number	1	0
Bit Name	SAMPLE_TRIG_2_EN	SAMPLE_TRIG_1_EN
Access	R/W	R/W
Default	0	1

**Bit 19-18: DTC\_MODE** – DTC Mode Select

00 = Only DTC phase adjust A utilized in edge adjustments (Default)

01 = Only DTC phase adjust B utilized in edge adjustments

10 = Both DTC phase adjust A and B utilized in edge adjustments

11 = Reserved

**Bit 17: DTC\_EN** – Enables Dead Time Compensation Mode

0 = Disabled (Default)

1 = Enabled

**Bit 16: BLANK\_PCM\_EN** – PCM Blanking Enable

0 = Blanking A window is not used with the PCM input (Default)

1 = Blanking A window is used with the PCM input

**Bits 15-12: SLAVE\_SYNC\_IN\_DIV\_RATIO** – Sets the number of syncs to be masked before a resync

**Bit 11-10: RESERVED** – Unused Bit

**Bits 9-8: FILTER\_DUTY\_SEL** – Sets which register is used for the max duty calculation at the Filter in RESON and MESH modes.

0 = PWM Period Register (Default)

1 = Event 2

2 = PWM Period Adjust Register (Bits 13:0)

**Bit 7: IDE\_DUTY\_B\_EN** – IDE Duty Cycle Side B Enable

0 = Disabled (Default)

1 = Enabled

**Bit 6: IDE\_DETECT\_EN** – IDE Detect Enable

0 = Disabled (Default)

1 = Enabled

**Bits 5-4: SAMPLE\_TRIG\_1\_OVERSAMPLE** – Oversample Select for Sample Trigger 1

00 = Trigger an EADC Sample at PWM Sample Trig Register value (Default)

01 = Trigger an EADC Sample at PWM Sample Trig Register value and at PWM Sample Trig Register value divided by 2

10 = Trigger a EADC Sample at PWM Sample Trig Register value, at PWM Sample Trig Register value divided by 2 and at PWM Sample Trig Register value divided by 4

11 = Trigger a EADC Sample at PWM Sample Trig Register value, at PWM Sample Trig Register value divided by 2, at PWM Sample Trig Register value divided by 4 and at PWM Sample Trig Register value divided by 8

**Bits 3-2: SAMPLE\_TRIG\_1\_MODE** – Mode select for Sample Trigger 1

00 = Trigger value is set using PWM Sample Trig Register value (Default)

01 = Trigger value is adaptive midpoint ( $EV1+CLA\_DUTY/2$  + Adaptive Offset) and uses current CLA value at update event

10 = Trigger value is adaptive midpoint ( $EV1+CLA\_DUTY$  + Adaptive Offset) and uses current CLA value at update event

11 = Trigger value is adaptive based on previous CBC location + Adaptive Offset

**Bit 1: SAMPLE\_TRIG\_2\_EN** – Sample Trigger 2 Enable

0 = Disable Sample Trigger 2 (Default)

1 = Enable Sample Trigger 2

**Bit 0: SAMPLE\_TRIG\_1\_EN** – Sample Trigger 1 Enable

0 = Disable Sample Trigger 1

1 = Enable Sample Trigger 1(Default)

#### **A.5.4 DPWM Period Register (DPWMPRD)**

**Address 0005000C – DPWM 3 Period Register**

**Address 0007000C – DPWM 2 Period Register**

**Address 000A000C – DPWM 1 Period Register**

**Address 000D000C – DPWM 0 Period Register**

Bit Number	17:4	3:0
Bit Name	PRD	RESERVED
Access	R/W	-
Default	00_0111_1101_0000	0000

**Bits 17-4: PRD** – PWM Period. Low resolution register, last 4 bits are read-only.

**Bits 3-0: RESERVED** – Unused bits

**A.5.5 DPWM Event 1 Register (DPWMEV1)**

Address 00050010 – DPWM 3 Event 1 Register

Address 00070010 – DPWM 2 Event 1 Register

Address 000A0010 – DPWM 1 Event 1 Register

Address 000D0010 – DPWM 0 Event 1 Register

Bit Number	17:4	3:0
Bit Name	EVENT1	RESERVED
Access	R/W	-
Default	00_0001_0100_0000	0000

**Bits 17-4: EVENT1** – Configures the location of Event 1. Low resolution register, last 4 bits are unused. Refer to DPWM app note for additional information.

**Bits 3-0: RESERVED** – Unused bits

**A.5.6 DPWM Event 2 Register (DPWMEV2)**

Address 00050014 – DPWM 3 Event 2 Register

Address 00070014 – DPWM 2 Event 2 Register

Address 000A0014 – DPWM 1 Event 2 Register

Address 000D0014 – DPWM 0 Event 2 Register

Bit Number	17:0
Bit Name	EVENT2
Access	R/W
Default	0_0000_0011_0000_0000

**Bits 17-0: EVENT2** – Configures the location of Event 2. Value equals number of PCLK clock periods in Bits 17:4 and number of high resolution clock phases of PCL in Bits 3:0 (dependent on Bits 3:2 of DPWM Control Register 2). Refer to DPWM app note for additional information.

**A.5.7 DPWM Event 3 Register (DPWMEV3)**

Address 00050018 – Loop 4 DPWM Event 3 Register

Address 00070018 – Loop 3 DPWM Event 3 Register

Address 000A0018 – Loop 2 DPWM Event 3 Register

Address 000D0018 – Loop 1 DPWM Event 3 Register

Bit Number	17:0
Bit Name	EVENT3
Access	R/W
Default	00_0000_0011_1110_0000

**Bits 17-0: EVENT3** – Configures the location of Event 3. Value equals number of PCLK clock periods in Bits 17:4 and number of high resolution clock phases of PCL in Bits 3:0. Refer to DPWM app note for additional information.

### A.5.8 DPWM Event 4 Register (DPWMEV4)

Address 0005001C – Loop 4 DPWM Event 4 Register

Address 0007001C – Loop 3 DPWM Event 4 Register

Address 000A001C – Loop 2 DPWM Event 4 Register

Address 000D001C – Loop 1 DPWM Event 4 Register

Bit Number	17:0
Bit Name	EVENT4
Access	R/W
Default	00_0000_0111_0000_0000

**Bits 17-0: EVENT4** – Configures the location of Event 4. Value equals number of PCLK clock periods in Bits 17:4 and number of high resolution clock phases of PCL in Bits 3:0. Refer to DPWM app note for additional information.

### A.5.9 DPWM Sample Trigger 1 Register (DPWMSAMPTRIG1)

Address 00050020 – DPWM 3 Sample Trigger 1 Register

Address 00070020 – DPWM 2 Sample Trigger 1 Register

Address 000A0020 – DPWM 1 Sample Trigger 1 Register

Address 000D0020 – DPWM 0 Sample Trigger 1 Register

Bit Number	17:6	5:0
Bit Name	SAMPLE_TRIGGER	RESERVED
Access	R/W	-
Default	0000_0000_0100	00_0000

**Bits 17-6: SAMPLE\_TRIGGER** – Configures the location of the sample trigger within a PWM period. Value equals the number of PCLK clock periods. Enables start of conversion for EADC. Refer to DPWM app note for additional information. Low resolution register, last 6 bits are read-only.

**Bits 5-0: RESERVED** – Unused bits

### A.5.10 DPWM Sample Trigger 2 Register (DPWMSAMPTRIG2)

Address 00050024 – DPWM 3 Sample Trigger 1 Register

Address 00070024 – DPWM 2 Sample Trigger 1 Register

Address 000A0024 – DPWM 1 Sample Trigger 1 Register

Address 000D0024 – DPWM 0 Sample Trigger 1 Register

Bit Number	17:6	5:0
Bit Name	SAMPLE_TRIGGER	RESERVED
Access	R/W	-
Default	0000_0000_0100	00_0000

**Bits 17-6: SAMPLE\_TRIGGER** – Configures the location of the sample trigger within a PWM period. Value equals the number of PCLK clock periods. Enables start of conversion for EADC. Refer to DPWM app note for additional information. Low resolution register, last 6 bits are read-only.

**Bits 5-0: RESERVED** – Unused bits

**A.5.11 DPWM Phase Trigger Register (DPWMPHASETRIG)**

Address 00050028 – DPWM 3 Phase Trigger Register

Address 00070028 – DPWM 2 Phase Trigger Register

Address 000A0028 – DPWM 1 Phase Trigger Register

Address 000D0028 – DPWM 0 Phase Trigger Register

Bit Number	17:4	3:0
Bit Name	PHASE_TRIGGER	RESERVED
Access	R/W	-
Default	00_0000_0000_0000	0000

**Bits 17-4: PHASE\_TRIGGER** – Configures the phase trigger delay within multi-output mode. Value equals the number of PCLK clock periods. Refer to DPWM app note for additional information. Low resolution register, last 4 bits are read-only

**Bits 3-0: RESERVED** – Unused bits

**A.5.12 DPWM Cycle Adjust A Register (DPWMCYCADJA)**

Address 0005002C – DPWM 3 Cycle Adjust A Register

Address 0007002C – DPWM 2 Cycle Adjust A Register

Address 000A002C – DPWM 1 Cycle Adjust A Register

Address 000D002C – DPWM 0 Cycle Adjust A Register

Bit Number	15:0
Bit Name	CYCLE_ADJUST_A
Access	R/W
Default	0000_0000_0000_0000

**Bits 15-0: CYCLE\_ADJUST\_A** – Adjusts PWM A output signal. 16-bit signed number allows output signal to be delayed or sped up. Refer to DPWM app note for additional information.

**A.5.13 DPWM Cycle Adjust B Register (DPWMCYCADJB)**

Address 00050030 – DPWM 3 Cycle Adjust B Register

Address 00070030 – DPWM 2 Cycle Adjust B Register

Address 000A0030 – DPWM 1 Cycle Adjust B Register

Address 000D0030 – DPWM 0 Cycle Adjust B Register

Bit Number	15:0
Bit Name	CYCLE_ADJUST_B
Access	R/W
Default	0000_0000_0000_0000

**Bits 15-0: CYCLE\_ADJUST\_B** – Adjusts the PWM B output signal. 16-bit signed number allows output signal to be delayed or sped up. Refer to DPWM app note for additional information.



**A.5.14 DPWM Filter Reference Register (DPWMRESDUTY)**

Address 00050034 – DPWM 3 Filter Reference Register

Address 00070034 – DPWM 2 Filter Reference Register

Address 000A0034 – DPWM 1 Filter Reference Register

Address 000D0034 – DPWM 0 Filter Reference Register

Bit Number	13:0
Bit Name	RESONANT_DUTY
Access	R/W
Default	00_0000_0000_0000

**Bits 13-0: RESONANT\_DUTY** – Sends resonant duty multiplier to a connected filter, if applicable

**A.5.15 DPWM Fault Control Register (DPWMFLTCTRL)**

Address 00050038 – DPWM 3 Fault Control Register

Address 00070038 – DPWM 2 Fault Control Register

Address 000A0038 – DPWM 1 Fault Control Register

Address 000D0038 – DPWM 0 Fault Control Register

Bit Number	31
Bit Name	ALL_FAULT_EN
Access	R/W
Default	0

Bit Number	30	29:24	23	22:16
Bit Name	CBC_FAULT_EN	CBC_MAX_COUNT	RESERVED	AB_MAX_COUNT
Access	R/W	R/W	-	R/W
Default	0	00_0000	0	000_0000

Bit Number	15	14:8	7	6:0
Bit Name	FLT_RESTART	A_MAX_COUNT	CBC_FAULT_MODE	B_MAX_COUNT
Access	R/W	R/W	R/W	R/W
Default	0	000_0000	0	000_0000

**Bit 31: ALL\_FAULT\_EN** – DPWM Fault Module enable

0 = All DPWM Fault Modules disabled (Default)

1 = All DPWM Fault Modules enabled

**Bit 30: CBC\_FAULT\_EN** – CBC Fault Module enable

0 = CBC Fault Modules disabled (Default)

1 = CBC Fault Modules enabled

**Bits 29-24: CBC\_MAX\_COUNT** – Cycle-by-Cycle Fault Count, sets the number of received sequential faults on Cycle-by-Cycle Fault input before asserting the fault

**Bits 23: RESERVED** – Unused bit

**Bits 22-16: AB\_MAX\_COUNT** – Fault AB Count, sets the number of received sequential faults on Fault AB input before asserting the fault

**Bits 15: FLT\_RESTART** – Enables DPWM after Fault.

0 = Enables DPWM on Falling Edge.

1 = Enables DPWM on Falling Edge.

**Bits 14-8: A\_MAX\_COUNT** – Fault A Count, sets the number of received sequential faults on Fault A input before asserting the fault

**Bits 7: CBC\_FAULT\_MODE** – CBC Fault Mode

0 = CBC Fault reacts to fault cbc input from fault mux

1 = CBC Fault reacts to output of frame CBC

**Bits 6-0: B\_MAX\_COUNT** – Fault B Count, sets the number of received sequential faults on Fault B input before asserting the fault

**A.5.16 DPWM Overflow Register (DPWMOVERFLOW)**

Address 0005003C – DPWM 3 Overflow Register

Address 0007003C – DPWM 2 Overflow Register

Address 000A003C – DPWM 1 Overflow Register

Address 000D003C – DPWM 0 Overflow Register

Bit Number	7	6	5	4	3:0
Bit Name	PWM_B_CHECK	PWM_A_CHECK	GPIO_B_IN	GPIO_A_IN	OVERFLOW
Access	R	R	R	R	R
Default	-	-	-	-	-

- Bit 7: PWM\_B\_CHECK** – Value of PWM B internal check  
 0 = Passed checks  
 1 = Failed checks (override required to enable output)
- Bit 6: PWM\_A\_CHECK** – Value of PWM B input  
 0 = Passed check  
 1 = Failed check (override required to enable output)
- Bit 5: GPIO\_B\_IN0** – Value of PWM B input  
 0 = Low signal on PWM B  
 1 = High signal on PWM B
- Bit 4: GPIO\_A\_IN** – Value of PWM A input  
 0 = Low signal on PWM A  
 1 = High value on PWM A
- Bit 3: OVERFLOW** – PWM Event 4 Overflow Status  
 0 = CLA Event 4 has not overflowed  
 1 = Overflow condition found on CLA Event 4
- Bit 2: OVERFLOW[2]** – CLA Event 4 Overflow Status  
 0 = PWM Event 4 has not overflowed  
 1 = Overflow condition found on PWM Event 4
- Bit 1: OVERFLOW[1]** – CLA Event 3 Overflow Status  
 0 = CLA Event 3 has not overflowed  
 1 = Overflow condition found on CLA Event 3
- Bit 0: OVERFLOW[0]** – CLA Event 2 Overflow Status  
 0 = CLA Event 2 has not overflowed  
 1 = Overflow condition found on CLA Event 2

### A.5.17 DPWM Flags/Interrupt Register (DPWMINT)

Address 00050040 – DPWM 3 Flags/Interrupt Register

Address 00070040 – DPWM 2 Flags/Interrupt Register

Address 000A0040 – DPWM 1 Flags/Interrupt Register

Address 000D0040 – DPWM 0 Flags/Interrupt Register

Bit Number	23	22	21	20	19	18	17	16
Bit Name	DTC_DISABLE	MODE_SWITCH	FLT_A	FLT_B	FLT_AB	FLT_CBC	PRD	INT
Access	R	R	R	R	R	R	R	R
Default	-	-	-	-	-	-	-	-

Bit Number	15:12	11	10
Bit Name	RESERVED	MODE_SWITCH_FLAG_CLR	MODE_SWITCH_FLAG_EN
Access	-	R/W	R/W
Default	0000	0	0

Bit Number	9	8	7
Bit Name	MODE_SWITCH_INT_EN	FLT_A_INT_EN	FLT_B_INT_EN
Access	R/W	R/W	R/W
Default	0	0	0

Bit Number	6	5	4	3:0
Bit Name	FLT_AB_INT_EN	FLT_CBC_INT_EN	PRD_INT_EN	PRD_INT_SCALE
Access	R/W	R/W	R/W	R/W
Default	0	0	0	1111

#### Bit 23: DTC\_DISABLE – DTC Disabled Flag

0 = Flag is not asserted

1 = Flag is set

#### Bit 22: MODE\_SWITCH – Mode Switching Flag

0 = Flag is not asserted

1 = Flag is set

#### Bit 21: FLT\_A – Fault A Flag

0 = Flag is not asserted

1 = Flag is set

#### Bit 20: FLT\_B – Fault B Flag

0 = Flag is not asserted

1 = Flag is set

#### Bit 19: FLT\_AB – Fault AB Flag

0 = Flag is not asserted

1 = Flag is set

#### Bit 18: FLT\_CBC – Fault Cycle-by-Cycle Flag

0 = Flag is not asserted

1 = Flag is set

#### Bit 17: PRD – PWM Period Interrupt Flag

0 = PWM Period Interrupt Flag is not asserted

1 = PWM Period Interrupt Flag is set

#### Bit 16: INT – Interrupt Out

0 = INT is not asserted

1 = INT is set

**Bits 15-12: RESERVED** – Unused bits

**Bit 11: MODE\_SWITCH\_FLAG\_CLR**– Mode Switching Flag Clear

0 = (Default)

1 = Risedge 0-1 clears flag generated.

**Bit 10: MODE\_SWITCH\_FLAG\_EN**– Mode Switching Flag Enable

0 = Disables generation of flag for Mode Switching (Default)

1 = Enables generation of flag for Mode Switching.

**Bit 9: MODE\_SWITCH\_INT\_EN** – Mode Switching Interrupt Enable

0 = Interrupt is not enabled (Default)

1 = Interrupt is enabled

**Bit 8: FLT\_A\_INT\_EN** – Fault A Flag Interrupt Enable

0 = Interrupt is not enabled (Default)

1 = Interrupt is enabled

**Bit 7: FLT\_B\_INT\_EN** – Fault B Flag Interrupt Enable

0 = Interrupt is not enabled (Default)

1 = Interrupt is enabled

**Bit 6: FLT\_AB\_INT\_EN** – Fault AB Flag Interrupt Enable

0 = Interrupt is not enabled (Default)

1 = Interrupt is enabled

**Bit 5: FLT\_CBC\_INT\_EN** – Fault Cycle-by-Cycle Flag Interrupt Enable

0 = Interrupt is not enabled (Default)

1 = Interrupt is enabled

**Bit 4: PRD\_INT\_EN** – PWM Period Interrupt Enable

0 = Disables generation of periodic PWM interrupt (Default)

1 = Enables generation of periodic PWM interrupt

**Bits 3-0: PRD\_INT\_SCALE** – This value scales the period interrupt signal from an interrupt every switching cycle to 16 switching cycles

0000 = Period Interrupt generated every switching cycle (Default)

0001 = Period Interrupt generated once every 2 switching cycles

0010 = Period Interrupt generated once every 4 switching cycles

0011 = Period Interrupt generated once every 6 switching cycles

0100 = Period Interrupt generated once every 8 switching cycles

0101 = Period Interrupt generated once every 16 switching cycles

0110 = Period Interrupt generated once every 32 switching cycles

0111 = Period Interrupt generated once every 48 switching cycles

1000 = Period Interrupt generated once every 64 switching cycles

1001 = Period Interrupt generated once every 80 switching cycles

1010 = Period Interrupt generated once every 96 switching cycles

1011 = Period Interrupt generated once every 128 switching cycles

1100 = Period Interrupt generated once every 160 switching cycles

1101 = Period Interrupt generated once every 192 switching cycles

1110 = Period Interrupt generated once every 224 switching cycles

1111 = Period Interrupt generated once every 256 switching cycles

#### **A.5.18 DPWM Counter Preset Register (DPWMCNTPRE)**

**Address 00050044 – DPWM 3 Counter Preset Register**

**Address 00070044 – DPWM 2 Counter Preset Register**

**Address 000A0044 – DPWM 1 Counter Preset Register**

**Address 000D0044 – DPWM 0 Counter Preset Register**

Bit Number	17:4	3:0
Bit Name	PRESET	RESERVED
Access	R/W	-

<b>Default</b>	00_0000_0000_0000	0000
----------------	-------------------	------

**Bit 17-4: PRESET** – Counter preset value, counter reset to this value upon detection of sync when PRESET\_EN bit in DPWMCTRL2 is enabled. Low resolution register, last 4 bits are read-only

**Bits 3-0: RESERVED** – Unused bits

#### **A.5.19 DPWM Blanking A Begin Register (DPWMBLKABEG)**

**Address 00050048 – DPWM 3 Blanking A Begin Register**

**Address 00070048 – DPWM 2 Blanking A Begin Register**

**Address 000A0048 – DPWM 1 Blanking A Begin Register**

**Address 000D0048 – DPWM 0 Blanking A Begin Register**

Bit Number	17:4	3:0
<b>Bit Name</b>	BLANK_A_BEGIN	RESERVED
<b>Access</b>	R/W	-
<b>Default</b>	00_0000_0000_0000	0000

**Bit 17-4: BLANK\_A\_BEGIN** – Configures start of Comparator Blanking Window for PWM A. Low resolution register, last 4 bits are read-only.

**Bits 3-0: RESERVED** – Unused bits

#### **A.5.20 DPWM Blanking A End Register (DPWMBLKAEND)**

**Address 0005004C – DPWM 3 Blanking A End Register**

**Address 0007004C – DPWM 2 Blanking A End Register**

**Address 000A004C – DPWM 1 Blanking A End Register**

**Address 000D004C – DPWM 0 Blanking A End Register**

Bit Number	17:4	3:0
<b>Bit Name</b>	BLANK_A_END	RESERVED
<b>Access</b>	R/W	-
<b>Default</b>	00_0000_0000_0000	0000

**Bit 17-4: BLANK\_A\_END** – Configures end of Comparator Blanking Window for PWM A. Low resolution register, last 4 bits are read-only.

**Bits 3-0: RESERVED** – Unused bits

#### A.5.21 DPWM Blanking B Begin Register (DPWMBLKBBEG)

Address 00050050 – DPWM 3 Blanking B Begin Register

Address 00070050 – DPWM 2 Blanking B Begin Register

Address 000A0050 – DPWM 1 Blanking B Begin Register

Address 000D0050 – DPWM 0 Blanking B Begin Register

Bit Number	17:4	3:0
Bit Name	BLANK_B_BEGIN	RESERVED
Access	R/W	-
Default	00_0000_0000_0000	0000

**Bit 17-4: BLANK\_B\_BEGIN** – Configures start of Comparator Blanking Window for PWM B. Low resolution register, last 4 bits are read-only.

**Bits 3-0: RESERVED** – Unused bits

#### A.5.22 DPWM Blanking B End Register (DPWMBLKBEND)

Address 00050054 – DPWM 3 Blanking B End Register

Address 00070054 – DPWM 2 Blanking B End Register

Address 000A0054 – DPWM 1 Blanking B End Register

Address 000D0054 – DPWM 0 Blanking B End Register

Bit Number	17:4	3:0
Bit Name	BLANK_B_END	RESERVED
Access	R/W	-
Default	00_0000_0000_0000	0000

**Bit 17-4: BLANK\_B\_END** – Configures end of Comparator Blanking Window for PWM B. Low resolution register, last 4 bits are read-only.

**Bits 3-0: RESERVED** – Unused bits

#### A.5.23 DPWM Minimum Duty Cycle High Register (DPWMMINDUTYHI)

Address 00050058 – DPWM 3 Minimum Duty Cycle High Register

Address 00070058 – DPWM 2 Minimum Duty Cycle High Register

Address 000A0058 – DPWM 1 Minimum Duty Cycle High Register

Address 000D0058 – DPWM 0 Minimum Duty Cycle High Register

Bit Number	17:4	3:0
Bit Name	MIN_DUTY_HIGH	RESERVED
Access	R/W	-
Default	00_0000_0000_0000	0000

**Bit 17-4: MIN\_DUTY\_HIGH**– Configures upper threshold for minimum duty cycle logic. Low resolution register, last 4 bits are read-only.

**Bits 3-0: RESERVED** – Unused bits

#### A.5.24 DPWM Minimum Duty Cycle Low Register (DPWMMINDUTYLO)

Address 0005005C – DPWM 3 Minimum Duty Cycle Low Register

Address 0007005C – DPWM 2 Minimum Duty Cycle Low Register

Address 000A005C – DPWM 1 Minimum Duty Cycle Low Register

Address 000D005C – DPWM 0 Minimum Duty Cycle Low Register

Bit Number	17:4	3: 0
Bit Name	MIN_DUTY_LOW	RESERVED
Access	R/W	-
Default	00_0000_0000_0000	0000

**Bit 17-4: MIN\_DUTY\_LOW**– Configures lower threshold for minimum duty cycle logic. Low resolution register, last 4 bits are read-only.

**Bits 3-0: RESERVED** – Unused bits

#### A.5.25 DPWM Adaptive Sample Register (DPWMADAPTIVE)

Address 00050060 – DPWM 3 Adaptive Sample Register

Address 00070060 – DPWM 2 Adaptive Sample Register

Address 000A0060 – DPWM 1 Adaptive Sample Register

Address 000D0060 – DPWM 0 Adaptive Sample Register

Bit Number	11:0
Bit Name	ADAPT_SAMP
Access	R/W
Default	0000_0000_0000

**Bit 13-0: ADAPT\_SAMP** – Configures Adaptive Sample Adjust

#### A.5.26 DPWM Fault Status (DPWMFLTSTAT)

Address 00050064 – DPWM 3 Fault Input Status Register

Address 00070064 – DPWM 2 Fault Input Status Register

Address 000A0064 – DPWM 1 Fault Input Status Register

Address 000D0064 – DPWM 0 Fault Input Status Register

Bit Number	5	4	3	2	1	0
Bit Name	BURST	IDE_DETECT	FLT_A	FLT_B	FLT_AB	FLT_CBC
Access	R	R	R	R	R	R
Default	-	-	-	-	-	-

**Bit 5: BURST** – Burst Mode Detection Status

0 = Burst Mode Detection is not asserted

1 = Burst Mode Detection is set

**Bit 4: IDE\_DETECT** – IDE Detection Status (from Analog Comparators)

0 = IDE Detection is not asserted

1 = IDE Detection is set

**Bit 3: FLT\_A** – Fault A Detection Status

0 = Fault A Detection is not asserted

1 = Fault A Detection is set

**Bit 2: FLT\_B** – Fault B Detection Status

0 = Fault B Detection is not asserted

1 = Fault B Detection is set



**Bit 1: FLT\_AB** – Fault AB Detection Status  
 0 = Fault AB Detection is not asserted  
 1 = Fault AB Detection is set

**Bit 0: FLT\_CBC** – Current Limit Detection Status  
 0 = Current Limit Detection is not asserted  
 1 = Current Limit Detection is set

#### **A.5.27 DPWM Auto Switch High Upper Thresh Register (DPWMAUTOSWHIUPTHRESH)**

**Address 00050068** – DPWM 3 Auto Switch High Upper Thresh Register

**Address 00070068** – DPWM 2 Auto Switch High Upper Thresh Register

**Address 000A0068** – DPWM 1 Auto Switch High Upper Thresh Register

**Address 000D0068** – DPWM 0 Auto Switch High Upper Thresh Register

Bit Number	17:4	3:0
Bit Name	AUTO_SWITCH_HIGH_UPPER	RESERVED
Access	R/W	-
Default	00_0000_0000_0000	0000

**Bit 17-4: AUTO\_SWITCH\_HIGH\_UPPER**– Configures upper threshold for Auto Switch Mode High operation. Mode switching does not occur between Auto Switch High Upper and Auto Switch High Lower thresholds. Low resolution register, last 4 bits are read-only.

**Bits 3-0: RESERVED** – Unused bits

### A.5.28 DPWM Auto Switch High Lower Thresh Register (DPWMAUTOSWHILOWTHRESH)

Address 0005006C – DPWM 3 Auto Switch High Lower Thresh Register

Address 0007006C – DPWM 2 Auto Switch High Lower Thresh Register

Address 000A006C – DPWM 1 Auto Switch High Lower Thresh Register

Address 000D006C – DPWM 0 Auto Switch High Lower Thresh Register

Bit Number	17:4	3:0
Bit Name	AUTO_SWITCH_HIGH_LOWER	RESERVED
Access	R/W	-
Default	00_0000_0000_0000	0000

**Bit 17-4: AUTO\_SWITCH\_HIGH\_LOWER**– Configures lower threshold for Auto Switch Mode High operation. Mode switching does not occur between Auto Switch High Upper and Auto Switch High Lower thresholds. Low resolution register, last 4 bits are read-only.

**Bits 3-0: RESERVED** – Unused bits

### A.5.29 DPWM Auto Switch Low Upper Thresh Register (DPWMAUTOSWLOUPHRESH)

Address 00050070 – DPWM 3 Auto Switch Low Upper Thresh Register

Address 00070070 – DPWM 2 Auto Switch Low Upper Thresh Register

Address 000A0070 – DPWM 1 Auto Switch Low Upper Thresh Register

Address 000D0070 – DPWM 0 Auto Switch Low Upper Thresh Register

Bit Number	17:4	3:0
Bit Name	AUTO_SWITCH_LOW_UPPER	RESERVED
Access	R/W	-
Default	00_0000_0000_0000	0000

**Bit 29-16: AUTO\_SWITCH\_LOW\_UPPER**– Configures upper threshold for Auto Switch Mode Low operation. Mode switching does not occur between Auto Switch Low Upper and Auto Switch Low Lower thresholds. Low resolution register, last 4 bits are read-only.

**Bits 3-0: RESERVED** – Unused bits

**A.5.30 DPWM Auto Switch Low Lower Thresh Register (DPWMAUTOSWLOWTHRESH)**

**Address 00050074 – DPWM 3 Auto Switch Low Lower Thresh Register**

**Address 00070074 – DPWM 2 Auto Switch Low Lower Thresh Register**

**Address 000A0074 – DPWM 1 Auto Switch Low Lower Thresh Register**

**Address 000D0074 – DPWM 0 Auto Switch Low Lower Thresh Register**

Bit Number	17:4	3:0
Bit Name	AUTO_SWITCH_LOW_LOWER	RESERVED
Access	R/W	-
Default	00_0000_0000_0000	0000

**Bit 29-16: AUTO\_SWITCH\_LOW\_LOWER**– Configures lower threshold for Auto Switch Mode Low operation. Mode switching does not occur between Auto Switch Low Upper and Auto Switch Low Lower thresholds. Low resolution register, last 4 bits are read-only.

**Bits 3-0: RESERVED** – Unused bits

### A.5.31 DPWM Auto Config Max Register (DPWMAUTOMAX)

Address 00050078 – DPWM 3 Auto Config Max Register

Address 00070078 – DPWM 2 Auto Config Max Register

Address 000A0078 – DPWM 1 Auto Config Max Register

Address 000D0078 – DPWM 0 Auto Config Max Register

Bit Number	31:28	27:24	23
Bit Name	PWM_B_INTRA_MUX	PWM_A_INTRA_MUX	CBC_PWM_C_EN
Access	R/W	R/W	R/W
Default	000	000	0

Bit Number	22:21	20
Bit Name	RESERVED	CBC_PWM_AB_EN
Access	-	R/W
Default	00	0

Bit Number	19	18:13
Bit Name	CBC_ADV_CNT_EN	RESERVED
Access	R/W	-
Default	0	00_0000

Bit Number	12
Bit Name	RESON_MODE_FIXED_DUTY_EN
Access	R/W
Default	0

Bit Number	11:8	6:4	3:2	1	0
Bit Name	RESERVED	PWM_MODE	RESERVED	CLA_EN	RESERVED
Access	-	R/W	-	R/W	-
Default	0000	000	00	0	0

**Bits 31-28: PWM\_B\_INTRA\_MUX** – Interchanges signals post edge generation

0 = Pass-through (Default)

- 1 = Edge-gen output, this module
- 2 = PWM-C, this module
- 3 = Crossover, this module
- 4 = Pass-through below A
- 5 = Pass-through below B
- 6 = Pass-through below C
- 7 = Pass-through below level-2 C
- 8 = Pass-through below level-3 C

**Bits 27-24: PWM\_A\_INTRA\_MUX** – Combines signals prior to HR module

0 = Pass-through (Default)

- 1 = Edge-gen output, this module
- 2 = PWM-C, this module
- 3 = Crossover, this module
- 4 = Pass-through below A

- 5 = Pass-through below B
- 6 = Pass-through below C
- 7 = Pass-through below level-2 C
- 8 = Pass-through below level-3 C

**Bit 23: CBC\_PWM\_C\_EN** – Sets if Fault CBC changes PWM-C output  
 0 = PWM-C unaffected by Fault CBC (Default)  
 1 = PWM-C affected by Fault CBC

**Bit 22-21: RESERVED** – Unused Bit

**Bit 20: CBC\_PWM\_AB\_EN** – Sets if Fault CBC changes output waveform for PWM-A and PWM-B  
 0 = PWM-A and PWM-B unaffected by Fault CBC (Default)  
 1 = PWM-A and PWM-B affected by Fault CBC

**Bit 19: CBC\_ADV\_CNT\_EN** – Selects cycle-by-cycle of operation

**Normal Mode**

- 0 = CBC disabled (Default)
- 1 = CBC enabled

**Multi and Resonant Modes**

- 0 = PWM-A and PWM-B operate independently (Default)
- 1 = PWM-A and PWM-B pulse matching enabled

**Bits 18-13: RESERVED** – Unused Bits

**Bit 12: RESON\_MODE\_FIXED\_DUTY\_EN** – Configures how duty cycle is controlled in Resonance Mode

- 0 = Resonant mode duty cycle set by Filter duty (Default)
- 1 = Resonant mode duty cycle set by Auto Switch High Register

**Bits 11-8: RESERVED** – Unused Bits

**Bits 7-4: PWM\_MODE** – DPWM Mode

- 0 = Normal Mode
- 1 = Resonant Mode
- 2 = Multi-Output Mode
- 3 = Triangular Mode
- 4 = Leading Mode

**Bits 3-2: RESERVED** – Unused Bits

**Bit 1: CLA\_EN**– CLA Processing Enable

- 0 = Generate PWM waveforms from PWM Register values (Default)
- 1 = Enable CLA input

**Bit 0: RESERVED** – Unused bit

### A.5.32 DPWM Auto Config Mid Register (DPWMAUTOMID)

**Address 0005007C** – DPWM 3 Auto Config Mid Register

**Address 0007007C** – DPWM 2 Auto Config Mid Register

**Address 000A007C** – DPWM 1 Auto Config Mid Register

**Address 000D007C** – DPWM 0 Auto Config Mid Register

Bit Number	31:28	27:24	23
Bit Name	PWM_B_INTRA_MUX	PWM_A_INTRA_MUX	CBC_PWM_C_EN
Access	R/W	R/W	R/W
Default	0000	0000	0

Bit Number	22:21	20

<b>Bit Name</b>	RESERVED	CBC_PWM_AB_EN
<b>Access</b>	-	R/W
<b>Default</b>	00	0

<b>Bit Number</b>	19	18:13
<b>Bit Name</b>	CBC_ADV_CNT_EN	RESERVED
<b>Access</b>	R/W	-
<b>Default</b>	0	00_0000

<b>Bit Number</b>	12
<b>Bit Name</b>	RESON_MODE_FIXED_DUTY_EN
<b>Access</b>	R/W
<b>Default</b>	0

<b>Bit Number</b>	11:8	6:4	3:2	1	0
<b>Bit Name</b>	RESERVED	PWM_MODE	RESERVED	CLA_EN	RESERVED
<b>Access</b>	-	R/W	-	R/W	-
<b>Default</b>	0000	0000	00	0	0

**Bits 31-28: PWM\_B\_INTRA\_MUX** – Interchanges signals post edge generation

- 0 = Pass-through (Default)
- 1 = Edge-gen output, this module
- 2 = PWM-C, this module
- 3 = Crossover, this module
- 4 = Pass-through below A
- 5 = Pass-through below B
- 6 = Pass-through below C
- 7 = Pass-through below level-2 C
- 8 = Pass-through below level-3 C

**Bits 27-24: PWM\_A\_INTRA\_MUX** – Combines signals prior to HR module

- 0 = Pass-through (Default)
- 1 = Edge-gen output, this module
- 2 = PWM-C, this module
- 3 = Crossover, this module
- 4 = Pass-through below A
- 5 = Pass-through below B
- 6 = Pass-through below C
- 7 = Pass-through below level-2 C
- 8 = Pass-through below level-3 C

**Bit 23: CBC\_PWM\_C\_EN** – Sets if Fault CBC changes PWM-C output

- 0 = PWM-C unaffected by Fault CBC (Default)
- 1 = PWM-C affected by Fault CBC

**Bit 22-21: RESERVED** – Unused Bits

**Bit 20: CBC\_PWM\_AB\_EN** – Sets if Fault CBC changes output waveform for PWM-A and PWM-B

- 0 = PWM-A and PWM-B unaffected by Fault CBC (Default)
- 1 = PWM-A and PWM-B affected by Fault CBC

**Bit 19: CBC\_ADV\_CNT\_EN** – Selects cycle-by-cycle of operation

- Normal Mode**
- 0 = CBC disabled (Default)

1 = CBC enabled

**Multi and Resonant Modes**

0 = PWM-A and PWM-B operate independently (Default)

1 = PWM-A and PWM-B pulse matching enabled

**Bits 18-13: RESERVED** – Unused Bits

**Bit 12: RESON\_MODE\_FIXED\_DUTY\_EN** – Configures how duty cycle is controlled in Resonance Mode

0 = Resonant mode duty cycle set by Filter duty (Default)

1 = Resonant mode duty cycle set by Auto Switch High Register

**Bits 11-7: RESERVED** – Unused Bits

**Bits 6-4: PWM\_MODE** – DPWM Mode

0 = Normal Mode

1 = Resonant Mode

2 = Multi-Output Mode

3 = Triangular Mode

4 = Leading Mode

**Bits 3-2: RESERVED** – Unused Bits

**Bit 1: CLA\_EN**– CLA Processing Enable

0 = Generate PWM waveforms from PWM Register values (Default)

1 = Enable CLA input

**Bit 0: RESERVED** – Unused bit

**A.5.33 DPWM Edge PWM Generation Control Register (DPWMEDGEGEN)**

**Address 00050080** – DPWM 3 Edge PWM Generation Control Register

**Address 00070080** – DPWM 2 Edge PWM Generation Control Register

**Address 000A0080** – DPWM 1 Edge PWM Generation Control Register

**Address 000D0080** – DPWM 0 Edge PWM Generation Control Register

Bit Number	16	15	14:12	11
Bit Name	EDGE_EN	RESERVED	A_ON_EDGE	RESERVED
Access	R/W	-	R/W	-
Default	0	0	000	0

Bit Number	10:8	7	6:4	3	2:0
Bit Name	A_OFF_EDGE	RESERVED	B_ON_EDGE	RESERVED	B_OFF_EDGE
Access	R/W	-	R/W	-	R/W
Default	001	0	010	0	011

**Bit 16: EDGE\_EN** – Enables edge generate module. When combining dpwm's, all modules must have this bit enabled.

**Bits 14-12: A\_ON\_EDGE** – Select input edge to trigger A ON output edge

0 = Current DPWM posedge A

1 = Current DPWM negedge A

2 = Current DPWM posedge B

3 = Current DPWM negedge B

4 = Below (n+1) DPWM posedge A

- 5 = Below (n+1) DPWM negedge A
- 6 = Below (n+1) DPWM posedge B
- 7 = Below (n+1) DPWM negedge B

**Bit 15: RESERVED** – Unused bit

**Bits 10-8: A\_OFF\_EDGE** – Select input edge to trigger A OFF output edge

- 0 = Current DPWM posedge A
- 1 = Current DPWM negedge A
- 2 = Current DPWM posedge B
- 3 = Current DPWM negedge B
- 4 = Below (n+1) DPWM posedge A
- 5 = Below (n+1) DPWM negedge A
- 6 = Below (n+1) DPWM posedge B
- 7 = Below (n+1) DPWM negedge B

**Bit 7: RESERVED** – Unused bit

**Bits 6-4: B\_ON\_EDGE** – Select input edge to trigger B ON output edge

- 0 = Current DPWM posedge A
- 1 = Current DPWM negedge A
- 2 = Current DPWM posedge B
- 3 = Current DPWM negedge B
- 4 = Below (n+1) DPWM posedge A
- 5 = Below (n+1) DPWM negedge A
- 6 = Below (n+1) DPWM posedge B
- 7 = Below (n+1) DPWM negedge B

**Bit 3: RESERVED** – Unused bit

**Bit 2-0: B\_OFF\_EDGE** – Select input edge to trigger B OFF output edge

- 0 = Current DPWM posedge A
- 1 = Current DPWM negedge A
- 2 = Current DPWM posedge B
- 3 = Current DPWM negedge B
- 4 = Below (n+1) DPWM posedge A
- 5 = Below (n+1) DPWM negedge A
- 6 = Below (n+1) DPWM posedge B
- 7 = Below (n+1) DPWM negedge B

**A.5.34 DPWM Filter Duty Read Register (DPWMFILTERDUTYREAD)**

**Address 00050084 – DPWM 3 Filter Duty Read Register**

**Address 00070084 – DPWM 2 Filter Duty Read Register**

**Address 000A0084 – DPWM 1 Filter Duty Read Register**

**Address 000D0084 – DPWM 0 Filter Duty Read Register**

<b>Bit Number</b>	<b>17:0</b>
<b>Bit Name</b>	FILTER_DUTY
<b>Access</b>	R
<b>Default</b>	-

**Bits 17-0: FILTER\_DUTY** – Filter Duty value received by DPWM Module

**A.5.35 DPWM CBC Location Register (DPWMCBCLOCATION)**

**Address 00050088 – DPWM 3 CBC Location Register**

**Address 00070088 – DPWM 2 CBC Location Register**

**Address 000A0088 – DPWM 1 CBC Location Register**

**Address 000D0088 – DPWM 0 CBC Location Register**

<b>Bit Number</b>	<b>13:0</b>
-------------------	-------------



---

<b>Bit Name</b>	CBC_LOCATION
<b>Access</b>	R
<b>Default</b>	-

**Bits 13-0: CBC\_LOCATION** – Counter Value when CBC occurs



## A.6 Filter Registers

Registers for Filter Modules 0-2 are identical in their bit definitions.

### A.6.1 Filter Status Register (*FILTERSTATUS*)

**Address 00060000 – Filter 2 Status Register**

**Address 00090000 – Filter 1 Status Register**

**Address 000C0000 – Filter 0 Status Register**

Bit Number	4	3	2
Bit Name	FILTER_BUSY	YN_LOW_CLAMP	YN_HIGH_CLAMP
Access	R	R	R
Default	-	-	-

Bit Number	1	0
Bit Name	KI_YN_LOW_CLAMP	KI_YN_HIGH_CLAMP
Access	R	R
Default	-	-

**Bit 4: FILTER\_BUSY** – Filter Busy Indicator

0 = Filter is waiting for new data

1 = Filter busy calculating

**Bit 3: YN\_LOW\_CLAMP** – PID Output Low Rail Indicator

0 = PID Output not equal to low rail

1 = PID Output equal to low rail

**Bit 2: YN\_HIGH\_CLAMP** – PID Output High Rail Indicator

0 = PID Output not equal to high rail

1 = PID Output equal to high rail

**Bit 1: KI\_YN\_LOW\_CLAMP** – KI Feedback Low Rail Indicator

0 = KI Feedback not equal to low rail

1 = KI Feedback equal to low rail

**Bit 0: KI\_YN\_HIGH\_CLAMP** – KI Feedback High Rail Indicator

0 = KI Feedback not equal to high rail

1 = KI Feedback equal to high rail

### A.6.2 Filter Control Register (*FILTERCTRL*)

Address 00060004 – Filter 2 Control Register

Address 00090004 – Filter 1 Control Register

Address 000C0004 – Filter 0 Control Register

Bit Number	15	14	13:12
Bit Name	KI_ADDER_MODE	PERIOD_MULT_SEL	OUTPUT_MULT_SEL
Access	R/W	R/W	R/W
Default	1	0	00

Bit Number	11:9	8	7	6	5
Bit Name	YN_SCALE	NL_MODE	KD_STALL	KI_STALL	KP_OFF
Access	R/W	R/W	R/W	R/W	R/W
Default	000	0	0	0	0

Bit Number	4	3	2	1	0
Bit Name	KD_OFF	KI_OFF	FORCE_START	USE_CPU_SAMPLE	FILTER_EN
Access	R/W	R/W	R/W	R/W	R/W
Default	0	0	0	0	1

**Bit 15: KI\_ADDER\_MODE** – Configures addition of  $X_n$  and  $X_{n-1}$  in Integral branch

0 = Only  $X_n$  used for addition ( $X_n + 0$ )

1 =  $X_n + X_{n-1}$  used for addition (Default)

**Bit 14: PERIOD\_MULT\_SEL** – Selects output multiplicand used for multiplying with filter output to calculate DPWM Period value in Resonant Mode

0 = Switching period received from Loop Mux module (Default)

1 = KComp received from Loop Mux module

**Bits 13-12: OUTPUT\_MULT\_SEL** – Selects output multiplicand used for multiplying with filter output to calculate DPWM Duty value

0 = KComp received from Loop Mux module (Default)

1 = Switching period received from Loop Mux module

2 = Feed-Forward value received from Loop Mux module

3 = Resonant Duty value received from DPWM Module

**Bit 11-9: YN\_SCALE** – Controls scaling of  $Y_n$  value to compensate for filter coefficient scaling

0 = Filter output ( $Y_n$ ) not scaled (Default)

1 = Filter output ( $Y_n$ ) right shifted by 1

2 = Filter output ( $Y_n$ ) right shifted by 2

3 = Filter output ( $Y_n$ ) right shifted by 3

4 = Filter output ( $Y_n$ ) left shifted by 4

5 = Filter output ( $Y_n$ ) left shifted by 3

6 = Filter output ( $Y_n$ ) left shifted by 2

7 = Filter output ( $Y_n$ ) left shifted by 1

**Bit 8: NL\_MODE** – Sets non-linear gain table configuration. Coefficient Bin mapping is controlled by Coefficient Configuration Register. Limit configuration is controlled by the Filter Nonlinear Limit Registers (See Sections 8.16-8.18)

0 = Non-symmetric mode (Default)

1 = Symmetric mode

**Bit 7: KD\_STALL** – Freezes KD Branch,  $KD_{YN}$  remains at current value

0 =  $KD_{YN}$  recalculated on each filter update (Default)

- 1 = KD\_YN stalled at present value
- Bit 6: KI\_STALL** – Freezes KI Branch, KI\_YN remains at current value  
 0 = KI\_YN recalculated on each filter update (Default)  
 1 = KI\_YN stalled at present value
- Bit 5: KP\_OFF** – Turns off the KP branch  
 0 = KP branch calculating new outputs (Default)  
 1 = KP branch turned off
- Bit 4: KD\_OFF** – Turns off the KD branch, KD\_YN cleared to zero  
 0 = KD branch calculating new outputs (Default)  
 1 = KD branch turned off
- Bit 3: KI\_OFF** – Turns off the KI branch, KI\_YN cleared to zero  
 0 = KI branch calculating new outputs (Default)  
 1 = KI branch halted
- Bit 2: FORCE\_START** – Initiates a filter calculation under firmware control  
 0 = No calculation started (Default)  
 1 = Calculation started
- Bit 1: USE\_CPU\_SAMPLE** – Forces filter to use error sample from CPU XN register (Section 8.3)  
 0 = Filter Mode, input data received from EADC (Default)  
 1 = CPU Mode, input data based on CPU XN register
- Bit 0: FILTER\_EN** – Filter Enable  
 0 = Disables Filter operation  
 1 = Enables Filter operation (Default)

### A.6.3 CPU XN Register (CPUXN)

**Address 00060008 – Filter 2 CPU XN Register**

**Address 00090008 – Filter 1 CPU XN Register**

**Address 000C0008 – Filter 0 CPU XN Register**

<b>Bit Number</b>	<b>8:0</b>
<b>Bit Name</b>	CPU_SAMPLE
<b>Access</b>	R/W
<b>Default</b>	0_0000_0000

**Bits 8-0: CPU\_SAMPLE** – Forced X<sub>n</sub> value, allows processor to use filter as ALU. Set Bit 2 of Filter Control Register to ‘1’ to force CPU\_SAMPLE as input to Filter.

#### A.6.4 Filter XN Read Register (*FILTERXNREAD*)

Address 0006000C – Filter 2 XN Read Register

Address 0009000C – Filter 1 XN Read Register

Address 000C000C – Filter 0 XN Read Register

Bit Number	24:16	15:9	8:0
Bit Name	XN_M1	RESERVED	XN
Access	R	-	R
Default	-	000_0000	-

Bits 24-16: XN\_M1 – 9-bit signed XN\_M1 register value, read-only

Bits 15-9: RESERVED

Bits 8-0: XN – 9-bit signed XN register value, read-only

#### A.6.5 Filter KI\_YN Read Register (*FILTERKIYNREAD*)

Address 00060010 – Filter 2 KI\_YN Read Register

Address 00090010 – Filter 1 KI\_YN Read Register

Address 000C0010 – Filter 0 KI\_YN Read Register

Bit Number	23:0
Bit Name	KI_YN
Access	R
Default	-

Bits 23-0: KI\_YN – 24-bit signed KI\_YN register value, read-only

#### A.6.6 Filter KD\_YN Read Register (*FILTERKDYNREAD*)

Address 00060014 – Filter 2 KD\_YN Register

Address 00090014 – Filter 1 KD\_YN Register

Address 000C0014 – Filter 0 KD\_YN Register

Bit Number	23:0
Bit Name	KD_YN
Access	R
Default	-

Bits 23-0: KD\_YN – 24-bit signed KD\_YN register value, read-only

### A.6.7 Filter YN Read Register (FILTERYNREAD)

Address 00060018 – Filter 2 YN Read Register

Address 00090018 – Filter 1 YN Read Register

Address 000C0018 – Filter 0 YN Read Register

Bit Number	23:0
Bit Name	YN
Access	R
Default	-

Bits 23-0: YN – 24-bit signed YN register value, read-only

### A.6.8 Coefficient Configuration Register (COEFCONFIG)

Address 0006001C – Filter 2 Coefficient Configuration Register

Address 0009001C – Filter 1 Coefficient Configuration Register

Address 000C001C – Filter 0 Coefficient Configuration Register

Bit Number	27	26:24	23	22:20
Bit Name	BIN6_ALPHA	BIN6_CONFIG	BIN5_ALPHA	BIN5_CONFIG
Access	R/W	R/W	R/W	R/W
Default	0	000	0	000

Bit Number	19	18:16	15	14:12	11
Bit Name	BIN4_ALPHA	BIN4_CONFIG	BIN3_ALPHA	BIN3_CONFIG	BIN2_ALPHA
Access	R/W	R/W	R/W	R/W	R/W
Default	0	000	0	000	0

Bit Number	10:8	7	6:4	3	2:0
Bit Name	BIN2_CONFIG	BIN1_ALPHA	BIN1_CONFIG	BIN0_ALPHA	BIN0_CONFIG
Access	R/W	R/W	R/W	R/W	R/W
Default	000	0	000	0	000

**Bit 27: BIN6\_ALPHA** – Selects which alpha value to use in Bin 6 of Non-Linear Table. These bits are shadowed and updated to filter when filter is not processing an EADC sample

0 = Bank 0 KD Alpha (KD\_ALPHA\_0) selected (Default)

1 = Bank 1 KD Alpha (KD\_ALPHA\_1) selected

**Bits 26-24: BIN6\_CONFIG** – Selects which coefficient set to place in Bin 6 of Non-Linear Table. These bits are shadowed and updated to filter when filter is not processing an EADC sample.

0 = Coefficient Set A Selected (Default)

1 = Coefficient Set B Selected

2 = Coefficient Set C Selected

3 = Coefficient Set D Selected

4 = Coefficient Set E Selected

5 = Coefficient Set F Selected

6 = Coefficient Set G Selected

**Bit 23: BIN5\_ALPHA** – Selects which alpha value to use in Bin 5 of Non-Linear Table. These bits are shadowed and updated to filter when filter is not processing an EADC sample

0 = Bank 0 KD Alpha (KD\_ALPHA\_0) selected (Default)

1 = Bank 1 KD Alpha (KD\_ALPHA\_1) selected

**Bits 22-20: BIN5\_CONFIG** – Selects which coefficient set to place in Bin 5 of Non-Linear Table. These bits are

shadowed and updated to filter when filter is not processing an EADC sample.

- 0 = Coefficient Set A Selected (Default)
- 1 = Coefficient Set B Selected
- 2 = Coefficient Set C Selected
- 3 = Coefficient Set D Selected
- 4 = Coefficient Set E Selected
- 5 = Coefficient Set F Selected
- 6 = Coefficient Set G Selected

**Bit 19: BIN4\_ALPHA** – Selects which alpha value to use in Bin 4 of Non-Linear Table. These bits are shadowed and updated to filter when filter is not processing an EADC sample

- 0 = Bank 0 KD Alpha (KD\_ALPHA\_0) selected (Default)
- 1 = Bank 1 KD Alpha (KD\_ALPHA\_1) selected

**Bits 18-16: BIN4\_CONFIG** – Selects which coefficient set to place in Bin 4 of Non-Linear Table. These bits are shadowed and updated to filter when filter is not processing an EADC sample.

- 0 = Coefficient Set A Selected (Default)
- 1 = Coefficient Set B Selected
- 2 = Coefficient Set C Selected
- 3 = Coefficient Set D Selected
- 4 = Coefficient Set E Selected
- 5 = Coefficient Set F Selected
- 6 = Coefficient Set G Selected

**Bit 15: BIN3\_ALPHA** – Selects which alpha value to use in Bin 3 of Non-Linear Table. These bits are shadowed and updated to filter when filter is not processing an EADC sample

- 0 = Bank 0 KD Alpha (KD\_ALPHA\_0) selected (Default)
- 1 = Bank 1 KD Alpha (KD\_ALPHA\_1) selected

**Bits 14-12: BIN3\_CONFIG** – Selects which coefficient set to place in Bin 3 of Non-Linear Table. These bits are shadowed and updated to filter when filter is not processing an EADC sample.

- 0 = Coefficient Set A Selected (Default)
- 1 = Coefficient Set B Selected
- 2 = Coefficient Set C Selected
- 3 = Coefficient Set D Selected
- 4 = Coefficient Set E Selected
- 5 = Coefficient Set F Selected
- 6 = Coefficient Set G Selected

**Bit 11: BIN2\_ALPHA** – Selects which alpha value to use in Bin 2 of Non-Linear Table. These bits are shadowed and updated to filter when filter is not processing an EADC sample

- 0 = Bank 0 KD Alpha (KD\_ALPHA\_0) selected (Default)
- 1 = Bank 1 KD Alpha (KD\_ALPHA\_1) selected

**Bits 10-8: BIN2\_CONFIG** – Selects which coefficient set to place in Bin 2 of Non-Linear Table. These bits are shadowed and updated to filter when filter is not processing an EADC sample.

- 0 = Coefficient Set A Selected (Default)
- 1 = Coefficient Set B Selected
- 2 = Coefficient Set C Selected
- 3 = Coefficient Set D Selected
- 4 = Coefficient Set E Selected
- 5 = Coefficient Set F Selected
- 6 = Coefficient Set G Selected

**Bit 7: BIN1\_ALPHA** – Selects which alpha value to use in Bin 1 of Non-Linear Table. These bits are shadowed and updated to filter when filter is not processing an EADC sample

- 0 = Bank 0 KD Alpha (KD\_ALPHA\_0) selected (Default)
- 1 = Bank 1 KD Alpha (KD\_ALPHA\_1) selected

**Bits 6-4: BIN1\_CONFIG** – Selects which coefficient set to place in Bin 1 of Non-Linear Table. These bits are shadowed and updated to filter when filter is not processing an EADC sample.

- 0 = Coefficient Set A Selected (Default)



- 1 = Coefficient Set B Selected
- 2 = Coefficient Set C Selected
- 3 = Coefficient Set D Selected
- 4 = Coefficient Set E Selected
- 5 = Coefficient Set F Selected
- 6 = Coefficient Set G Selected

**Bit 3: BIN0\_ALPHA** – Selects which alpha value to use in Bin 0 of Non-Linear Table. These bits are shadowed and updated to filter when filter is not processing an EADC sample

- 0 = Bank 0 KD Alpha (KD\_ALPHA\_0) selected (Default)
- 1 = Bank 1 KD Alpha (KD\_ALPHA\_1) selected

**Bits 2-0: BIN1\_CONFIG** – Selects which coefficient set to place in Bin 1 of Non-Linear Table. These bits are shadowed and updated to filter when filter is not processing an EADC sample.

- 0 = Coefficient Set A Selected (Default)
- 1 = Coefficient Set B Selected
- 2 = Coefficient Set C Selected
- 3 = Coefficient Set D Selected
- 4 = Coefficient Set E Selected
- 5 = Coefficient Set F Selected
- 6 = Coefficient Set G Selected

#### **A.6.9 Filter KP Coefficient 0 Register (FILTERKPCOEF0)**

**Address 00060020 – Filter 2 KP Coefficient 0 Register**

**Address 00090020 – Filter 1 KP Coefficient 0 Register**

**Address 000C0020 – Filter 0 KP Coefficient 0 Register**

Bit Number	31:16	15:0
Bit Name	KP_COEF_1	KP_COEF_0
Access	R/W	R/W
Default	0000_0000_0000_0000	0100_0010_0011_0100

**Bits 31-16: KP\_COEF\_1** – KP Coefficient 1, 16-bit signed coefficient, configurable to any bin using the Coefficient Control Register

**Bits 15-0: KP\_COEF\_0** – KP Coefficient 0, 16-bit signed coefficient, configurable to any bin using the Coefficient Control Register

#### **A.6.10 Filter KP Coefficient 1 Register (FILTERKPCOEF1)**

**Address 00060024 – Filter 2 KP Coefficient 1 Register**

**Address 00090024 – Filter 1 KP Coefficient 1 Register**

**Address 000C0024 – Filter 0 KP Coefficient 1 Register**

Bit Number	15:0
Bit Name	KP_COEF_2
Access	R/W
Default	0000_0000_0000_0000

**Bits 15-0: KP\_COEF\_2** – KP Coefficient 2, 16-bit signed coefficient, configurable to any bin using the Coefficient Control Register

#### **A.6.11 Filter KI Coefficient 0 Register (FILTERKICOEF0)**

**Address 00060028 – Filter 2 KI Coefficient 0 Register**

**Address 00090028 – Filter 1 KI Coefficient 0 Register**

**Address 000C0028 – Filter 0 KI Coefficient 0 Register**

Bit Number	31:16	15:0
Bit Name	KI_COEF_1	KI_COEF_0
Access	R/W	R/W
Default	0000_0000_0000_0000	0010_0100_0001_0010

**Bits 31-16: KI\_COEF\_1** – KI Coefficient 1, 16-bit signed coefficient, configurable to any bin using the Coefficient Control Register

**Bits 15-0: KI\_COEF\_0** – KI Coefficient 0, 16-bit signed coefficient, configurable to any bin using the Coefficient Control Register

**A.6.12 Filter KI Coefficient 1 Register (FILTERKICOEF1)**
**Address 0006002C – Filter 2 KI Coefficient 1 Register**
**Address 0009002C – Filter 1 KI Coefficient 1 Register**
**Address 000C002C – Filter 0 KI Coefficient 1 Register**

Bit Number	31:16	15:0
Bit Name	KI_COEF_3	KI_COEF_2
Access	R/W	R/W
Default	0000_0000_0000_0000	0000_0000_0000_0000

**Bits 31-16: KI\_COEF\_3** – KI Coefficient 3, 16-bit signed coefficient, configurable to any bin using the Coefficient Control Register

**Bits 15-0: KI\_COEF\_2** – KI Coefficient 2, 16-bit signed coefficient, configurable to any bin using the Coefficient Control Register

**A.6.13 Filter KD Coefficient 0 Register (FILTERKDCOEF0)**
**Address 00060030 – Filter 2 KD Coefficient 0 Register**
**Address 00090030 – Filter 1 KD Coefficient 0 Register**
**Address 000C0030 – Filter 0 KD Coefficient 0 Register**

Bit Number	31:16	15:0
Bit Name	KD_COEF_1	KD_COEF_0
Access	R/W	R/W
Default	0000_0000_0000_0000	1100_0100_0000_0001

**Bits 31-16: KD\_COEF\_1** – KD Coefficient 1, 16-bit signed coefficient, configurable to any bin using the Coefficient Control Register

**Bits 15-0: KD\_COEF\_0** – KD Coefficient 0, 16-bit signed coefficient, configurable to any bin using the Coefficient Control Register

**A.6.14 Filter KD Coefficient 1 Register (FILTERKDCOEF1)**
**Address 00060034 – Filter 2 KD Coefficient 1 Register**
**Address 00090034 – Filter 1 KD Coefficient 1 Register**
**Address 000C0034 – Filter 0 KD Coefficient 1 Register**

Bit Number	15:0
Bit Name	KD_COEF_2
Access	R/W
Default	0000_0000_0000_0000

**Bits 15-0: KD\_COEF\_2** – KD Coefficient 2, 16-bit signed coefficient, configurable to any bin using the Coefficient Control Register

**A.6.15 Filter KD Alpha Register (FILTERKDALPHA)**

Address 00060038 – Filter 2 KD Alpha Register

Address 00090038 – Filter 1 KD Alpha Register

Address 000C0038 – Filter 0 KD Alpha Register

Bit Number	24:16	15:9	8:0
Bit Name	KD_ALPHA_1	RESERVED	KD_ALPHA_0
Access	R/W	-	R/W
Default	0_0000_0000	000_0000	0_0101_0010

Bits 24-16: **KD\_ALPHA\_1** – Bank 1 KD Alpha, 9-bit signed value, configurable to any bin using the Coefficient Control Register

Bits 15-9: **RESERVED**

Bits 8-0: **KD\_ALPHA\_0** – Bank 0 KD Alpha, 9-bit signed value, configurable to any bin using the Coefficient Control Register

**A.6.16 Filter Nonlinear Limit Register 0 (FILTERNL0)**

Address 0006003C – Filter 2 Nonlinear Limit Register 0

Address 0009003C – Filter 1 Nonlinear Limit Register 0

Address 000C003C – Filter 0 Nonlinear Limit Register 0

Bit Number	24:16	15:9	8:0
Bit Name	LIMIT1	RESERVED	LIMIT0
Access	R/W	-	R/W
Default	0_0000_0000	000_0000	0_1111_1111

Bits 24-16: **LIMIT1** – Configures LIMIT1 in Nonlinear Coefficient tables

Bits 15-9: **RESERVED**

Bits 8-0: **LIMIT0** – Configures LIMIT0 in Nonlinear Coefficient tables

**A.6.17 Filter Nonlinear Limit Register 1 (FILTERNL1)**

Address 00060040 – Filter 2 Nonlinear Limit Register 1

Address 00090040 – Filter 1 Nonlinear Limit Register 1

Address 000C0040 – Filter 0 Nonlinear Limit Register 1

Bit Number	24:16	15:9	8:0
Bit Name	LIMIT3	RESERVED	LIMIT2
Access	R/W	-	R/W
Default	0_0000_0000	000_0000	0_0000_0000

Bits 24-16: **LIMIT3** – Configures LIMIT3 in Nonlinear Coefficient tables

Bits 15-9: **RESERVED**

Bits 8-0: **LIMIT2** – Configures LIMIT2 in Nonlinear Coefficient tables

**A.6.18 Filter Nonlinear Limit Register 2 (FILTERNL2)**

Address 00060044 – Filter 2 Nonlinear Limit Register 2

Address 00090044 – Filter 1 Nonlinear Limit Register 2

**Address 000C0044 – Filter 0 Nonlinear Limit Register 2**

Bit Number	24:16	15:9	8:0
Bit Name	LIMIT5	RESERVED	LIMIT4
Access	R/W	-	R/W
Default	0_0000_0000	000_0000	0_0000_0000

**Bits 24-16: LIMIT5** – Configures LIMIT5 in Nonlinear Coefficient tables

**Bits 15-9: RESERVED**

**Bits 8-0: LIMIT4** – Configures LIMIT4 in Nonlinear Coefficient tables

**A.6.19 Filter KI Feedback Clamp High Register (FILTERKICLPHI)**

**Address 00060048 – Filter 2 KI Feedback Clamp High Register**

**Address 00090048 – Filter 1 KI Feedback Clamp High Register**

**Address 000C0048 – Filter 0 KI Feedback Clamp High Register**

Bit Number	23:0
Bit Name	KI_CLAMP_HIGH
Access	R/W
Default	0111_1111_1111_1111_1111_1111

**Bits 23-0: KI\_CLAMP\_HIGH** – Sets the upper limit of KI\_YN value. If calculated KI\_YN exceeds this threshold, the KI\_YN register will be set to KI\_CLAMP\_HIGH

**A.6.20 Filter KI Feedback Clamp Low Register (FILTERKICLPLO)**

**Address 0006004C – Filter 2 KI Feedback Clamp Low Register**

**Address 0009004C – Filter 1 KI Feedback Clamp Low Register**

**Address 000C004C – Filter 0 KI Feedback Clamp Low Register**

Bit Number	23:0
Bit Name	KI_CLAMP_LOW
Access	R/W
Default	0000_0000_0000_0000_0000_0000

**Bits 23-0: KI\_CLAMP\_LOW** – Sets the lower limit of KI\_YN value. If calculated KI\_YN falls below this threshold, the KI\_YN register will be set to KI\_CLAMP\_LOW

**A.6.21 Filter YN Clamp High Register (FILTERYNCLPHI)**

Address 00060050 – Filter 2 YN Clamp High Register

Address 00090050 – Filter 1 YN Clamp High Register

Address 000C0050 – Filter 0 YN Clamp High Register

<b>Bit Number</b>	<b>23:0</b>
<b>Bit Name</b>	YN_CLAMP_HIGH
<b>Access</b>	R/W
<b>Default</b>	0111_1111_1111_1111_1111_1111

**Bits 23-0: YN\_CLAMP\_HIGH** – Sets the upper limit of YN value. If calculated YN exceeds this threshold, the YN register will be set to YN\_CLAMP\_HIGH

**A.6.22 Filter YN Clamp Low Register (FILTERYNCLPLO)**

Address 00060054 – Filter 2 YN Clamp Low Register

Address 00090054 – Filter 1 YN Clamp Low Register

Address 000C0054 – Filter 0 YN Clamp Low Register

<b>Bit Number</b>	<b>23:0</b>
<b>Bit Name</b>	YN_CLAMP_LOW
<b>Access</b>	R/W
<b>Default</b>	0000_0000_0000_0000_0000_0000

**Bits 23-0: YN\_CLAMP\_LOW** – Sets the lower limit of YN value. If calculated YN falls below this threshold, the YN register will be set to YN\_CLAMP\_LOW

**A.6.23 Filter Output Clamp High Register (FILTEROCLPHI)**

Address 00060058 – Filter 2 Output Clamp High Register

Address 00090058 – Filter 1 Output Clamp High Register

Address 000C0058 – Filter 0 Output Clamp High Register

<b>Bit Number</b>	<b>17:0</b>
<b>Bit Name</b>	OUTPUT_CLAMP_HIGH
<b>Access</b>	R/W
<b>Default</b>	11_1111_1111_1111_1111

**Bits 17-0: OUTPUT\_CLAMP\_HIGH** – Sets the upper limit of filter output value. If calculated filter output exceeds this threshold, the filter output will be set to OUTPUT\_CLAMP\_HIGH

**A.6.24 Filter Output Clamp Low Register (FILTEROCLPLO)**

Address 0006005C – Filter 2 Output Clamp Low Register

Address 0009005C – Filter 1 Output Clamp Low Register

Address 000C005C – Filter 0 Output Clamp Low Register

<b>Bit Number</b>	<b>17:0</b>
<b>Bit Name</b>	OUTPUT_CLAMP_LOW
<b>Access</b>	R/W
<b>Default</b>	00_0000_0000_0000_0000

**Bits 17-0: OUTPUT\_CLAMP\_LOW** – Sets the lower limit of filter output value. If calculated filter output falls below this threshold, the filter output will be set to OUTPUT\_CLAMP\_LOW

**A.6.25 Filter Preset Register (FILTERPRESET)**

Address 00060060 – Filter 2 Filter Preset Register

Address 00090060 – Filter 1 Filter Preset Register

Address 000C0060 – Filter 0 Filter Preset Register

<b>Bit Number</b>	<b>27</b>	<b>26:24</b>	<b>23:0</b>
<b>Bit Name</b>	PRESET_EN	PRESET_REG_SEL	PRESET_VALUE
<b>Access</b>	R/W	R/W	R/W
<b>Default</b>	00	000	0000_0000_0000_0000_0000_0000

**Bit 27: PRESET\_EN** – Set to ‘1’ to initiate write of internal filter register (Self cleared by hardware after successful programming)

**Bits 26-24: PRESET\_REG\_SEL** – Selects internal filter register to preset by processor

0 = XN\_M1 Register (only bits 10:0 of PRESET\_VALUE will be programmed into register)

1 = KI\_YN Register

2 = KD\_YN Register

3 = YN Register

4 = 18-bit Filter Data Register (after multiplication)

**Bits 23-0: PRESET\_VALUE** – Value to preset into selected register

## A.7 Front End Control Registers

Registers for Front End Control modules 0-2 are identical in their bit definitions

### A.7.1 Ramp Control Register (RAMPCTRL)

Address 0x0008\_0000 – Front End Control 2 Ramp Control Register

Address 0x000B\_0000 – Front End Control 1 Ramp Control Register

Address 0x000E\_0000 – Front End Control 0 Ramp Control Register

Bit Number	29:16	15:13	12
Bit Name	SYNC_FET_RAMP_START	RESERVED	RAMP_SAT_EN
Access	R/W	-	R/W
Default	00_0000_0000_0000	00	0

Bit Number	11	10	9
Bit Name	RAMP_COMP_INT_EN	RAMP_DLY_INT_EN	PREBIAS_INT_EN
Access	R/W	R/W	R/W
Default	0	0	0

Bit Number	8	7	6:5	4
Bit Name	PCM_START_SEL	SYNC_FET_EN	MASTER_SEL	SLAVE_COMP_EN
Access	R/W	R/W	R/W	R/W
Default	0	0	00	0

Bit Number	3	2	1	0
Bit Name	SLAVE_DELAY_EN	CONTROL_EN	FIRMWARE_START	RAMP_EN
Access	R/W	R/W	R/W	R/W
Default	0	0	0	0

**Bits 29-16: SYNC\_FET\_RAMP\_START** – Provides the starting value for the SyncFET Ramp with a resolution of High Frequency Oscillator Period/bit

**Bits 15-13: RESERVED** – Unused Bits

**Bit 12: RAMP\_SAT\_EN** – Enables addition or subtraction of DAC Saturation Step when EADC is in saturation.

0 = DAC Saturation Step logic is disabled, DAC incremented/decremented by value calculated by Ramp logic when EADC is in saturation (Default)

1 = DAC Saturation Step logic is enabled, DAC incremented/decremented by value stored in DAC Saturation Step register when EADC is in saturation

**Bit 11: RAMP\_COMP\_INT\_EN** – Enables Ramp I/F Interrupt when soft-start/power-down ramp procedure is complete

0 = Soft-start/Power-Down Ramp Complete Interrupt is disabled (Default)

1 = Soft-start/Power-Down Ramp Complete Interrupt is enabled

**Bit 10: RAMP\_DLY\_INT\_EN** – Enables Ramp I/F Interrupt when ramp delay procedure is complete

0 = Soft-start/Power-Down Ramp Delay Complete Interrupt is disabled (Default)

1 = Soft-start/Power-Down Ramp Delay Complete Interrupt is enabled

**Bit 9: PREBIAS\_INT\_EN** – Enables Ramp I/F Interrupt when Pre-Bias procedure is completed

0 = Pre-bias Complete Interrupt is disabled (Default)

1 = Pre-bias Complete Interrupt is enabled

**Bit 8: PCM\_START\_SEL** – Peak Current Mode Ramp Start Value Select



- 0 = Ramp starts from value programmed in DAC\_VALUE bits in EADC\_DAC\_VALUE Register (Default)  
 1 = Ramp starts from filter output selected by PCM\_SEL bits in Front End Control Mux Register
- Bit 7: SYNC\_FET\_EN** – Enables SyncFET Ramp Operation  
 0 = SyncFET Ramp Operation disabled (Default)  
 1 = SyncFET Ramp Operation enabled
- Bits 6-5: MASTER\_SEL** – Selects Master Ramp I/F in slave mode  
 0 = Front End Control 0 acts as master (Default)  
 1 = Front End Control 1 acts as master  
 2 = Front End Control 2 acts as master
- Bit 4: SLAVE\_COMP\_EN** – Enables syncing of ramp start to Master Ramp I/F Complete pulse  
 0 = Ramp initiated by Master Ramp Complete pulse disabled (Default)  
 1 = Ramp initiated by Master Ramp Complete pulse enabled
- Bit 3: SLAVE\_DELAY\_EN** – Enables syncing of ramp start to Master Ramp I/F Delay Complete pulse  
 0 = Ramp initiated by Master Ramp Delay Complete pulse disabled (Default)  
 1 = Ramp initiated by Master Ramp Delay Complete pulse enabled
- Bit 2: CONTROL\_EN** – Enables PMBus Control line to initiate ramp  
 0 = PMBus Control does not initiate ramp (Default)  
 1 = PMBus Control initiates ramp
- Bit 1: FIRMWARE\_START** – Ramp start bit, self-clearing by ramp logic  
 0 = No ramp sequence initiated by firmware (Default)  
 1 = Ramp sequence initiated by firmware
- Bit 0: RAMP\_EN** – Enable Ramp Logic (Pre-biasing should be disabled before asserting ramp, bit 16 of Pre-Bias Control Register)  
 0 = No soft start or power-down ramp controlled by hardware (Default)  
 1 = Enables hardware control of soft start or power-down ramp

### A.7.2 Ramp Status Register (RAMPSTAT)

Address 0x0008\_0004 – Front End Control 2 Ramp Status Register

Address 0x000B\_0004 – Front End Control 1 Ramp Status Register

Address 0x000E\_0004 – Front End Control 0 Ramp Status Register

Bit Number	11	10	9
Bit Name	EADC_DONE_RAW	RAMP_COMP_INT_STATUS	RAMP_DLY_INT_STATUS
Access	R	R	R
Default	-	-	-

Bit Number	8	7	6
Bit Name	PREBIAS_INT_STATUS	EADC_SAT_HIGH	EADC_SAT_LOW
Access	R	R	R
Default	-	-	-

Bit Number	5	4	3
Bit Name	EADC_EOC	PREBIAS_BUSY	RAMP_BUSY
Access	R	R	R
Default	-	-	-

Bit Number	2	1	0
Bit Name	RAMP_COMP_STATUS	RAMP_DLY_STATUS	PREBIAS_STATUS
Access	R	R	R
Default	-	-	-

**Bit 11: EADC\_DONE\_RAW** – EADC Conversion Done Raw Status

0 = EADC Conversion has not completed

1 = EADC Conversion has completed

**Bit 10: RAMP\_COMP\_INT\_STATUS** – Ramp Complete latched status

0 = No Ramp Complete has been declared

1 = Ramp Complete has been declared

**Bit 9: RAMP\_DLY\_INT\_STATUS** – Ramp Delay Complete latched status

0 = No Ramp Delay Complete has been declared

1 = Ramp Delay Complete has been declared

**Bit 8: PREBIAS\_INT\_STATUS** – Pre-Bias Complete latched status

0 = No Pre-Bias Complete has been declared

1 = Pre-Bias Complete has been declared

**Bit 7: EADC\_SAT\_HIGH** – EADC Saturation High Indicator

0 = EADC output is not saturated at high limit

1 = EADC output is saturated at high limit

**Bit 6: EADC\_SAT\_LOW** – EADC Saturation Low Indicator

0 = EADC output is not saturated at low limit

1 = EADC output is saturated at low limit

**Bit 5: EADC\_EOC** – Indicates EADC end of conversion

**Bit 4: PRE\_BIAS\_BUSY** – Pre-Bias Busy

0 = Pre-Bias is not in progress

1 = Pre-Bias in progress

**Bit 3: RAMP\_BUSY** – Ramp Busy

0 = Soft-Start/Power-Down Ramp is not in progress

- 1 = Soft-Start/Power-Down Ramp is in progress
- Bit 2: RAMP\_COMP\_STATUS** – Ramp Complete, Raw Status  
 0 = Ramp procedure is not complete  
 1 = Ramp procedure is complete
- Bit 1: RAMP\_DLY\_STATUS** – Ramp Delay Complete, Raw Status  
 0 = Ramp delay procedure is not complete  
 1 = Ramp delay procedure is complete
- Bit 0: PRE\_BIAS\_STATUS** – Pre-Bias Complete, Raw Status  
 0 = Pre-Bias is not completed  
 1 = Pre-Bias is completed

### A.7.3 Ramp Cycle Register (RAMPCYCLE)

**Address 0x0008\_0008** – Front End Control 2 Ramp Cycle Register

**Address 0x000B\_0008** – Front End Control 1 Ramp Cycle Register

**Address 0x000E\_0008** – Front End Control 0 Ramp Cycle Register

Bit Number	23:8	7	6:0
Bit Name	DELAY_CYCLES	RESERVED	SWITCH_CYC_PER_STEP
Access	R/W	-	R/W
Default	0000_0000_0000_0000	0	000_0000

**Bits 23-8: DELAY\_CYCLES** – Configures the number of delay cycles before an initiation of ramp sequence. Each delay cycle consists of n switching cycles, as specified by SWITCH\_CYC\_PER\_STEP (Bits 6-0). Number of delay cycles can vary from 0 to 65535

- 0 = Ramp starts without delay (Default)
- 1 = Ramp starts after (1\*SWITCH\_CYC\_PER\_STEP) switching cycles
- 2 = Ramp starts after (2\*SWITCH\_CYC\_PER\_STEP) switching cycles

.....

65535 = Ramp starts after (65535\*SWITCH\_CYC\_PER\_STEP) switching cycles

**Bit 7: RESERVED**

**Bits 6-0: SWITCH\_CYC\_PER\_STEP** – Selects number of switching cycles per DAC step. Number of subcycles can vary from 1 to 128.

- 0 = 1 switching cycle per step (Default)
  - 1 = 2 subcycles per cycle
  - 2 = 3 subcycles per cycle
- .....
- 127 = 128 subcycles per cycle

#### A.7.4 EADC DAC Value Register (EADC DAC)

Address 0x0008\_000C – Front End Control 2 EADC DAC Value Register

Address 0x000B\_000C – Front End Control 1 EADC DAC Value Register

Address 0x000E\_000C – Front End Control 0 EADC DAC Value Register

Bit Number	16	15	14	13:0
Bit Name	DAC_DITHER_ON_SAMPLE	DAC_DITHER_EN	RESERVED	DAC_VALUE
Access	R/W	R/W	-	R/W
Default	0	0	0	00_1111_1111_0000

**Bit 16: DAC\_DITHER\_ON\_SAMPLE** – DAC Dither on Sample

0 = Dither on sample trigger disabled (default)

1 = Dither on sample trigger enabled

**Bit 15: DAC\_DITHER\_EN** – DAC Dithering Enable

0 = DAC Dithering disabled (Default)

1 = DAC Dithering enabled

**Bit 15: RESERVED**

**Bits 13-0: DAC\_VALUE** - Programmable DAC Value, effective LSB equals 0.09765625mV

#### A.7.5 Ramp DAC Ending Value Register (RAMPDACEND)

Address 0x0008\_0010 – Front End Control 2 Ramp DAC Ending Register

Address 0x000B\_0010 – Front End Control 1 Ramp DAC Ending Register

Address 0x000E\_0010 – Front End Control 0 Ramp DAC Ending Register

Bit Number	13:0
Bit Name	RAMP_DAC_VALUE
Access	R/W
Default	00_0000_0000_0000

**Bits 13-0: RAMP\_DAC\_VALUE** – Programmable Ramp Ending DAC Value, LSB equals 0.09765625mV

#### A.7.6 DAC Step Register (DACSTEP)

Address 0x0008\_0014 – Front End Control 2 DAC Step Register

Address 0x000B\_0014 – Front End Control 1 DAC Step Register

Address 0x000E\_0014 – Front End Control 0 DAC Step Register

Bit Number	17:0
Bit Name	DAC_STEP
Access	R/W
Default	00_0000_0000_0000_0000

**Bits 17-0: DAC\_STEP** – Programmable 18-bit unsigned DAC Step. Bits 17:10 represent the real portion of the DAC Step (0-255 DAC counts at bit resolution of 0.09765625mV). Bits 9:0 represent the fractional portion of the DAC Step.

**A.7.7 DAC Saturation Step Register (DACSATSTEP)**

**Address 0x0008\_0018 – Front End Control 2 DAC Saturation Step Register**

**Address 0x000B\_0018 – Front End Control 1 DAC Saturation Step Register**

**Address 0x000E\_0018 – Front End Control 0 DAC Saturation Step Register**

<b>Bit Number</b>	<b>13:0</b>
<b>Bit Name</b>	DAC_SAT_STEP
<b>Access</b>	R/W
<b>Default</b>	00_0000_0000_0000

**Bits 13-0: DAC\_SAT\_STEP** – Programmable DAC Saturation Step, LSB equals 0.009765625mV

0 = DAC not adjusted on EADC saturation during ramp (Default)

1 = DAC adjusted by 1 DAC count on EADC saturation during ramp

.....

1023 = DAC adjusted by 1023 DAC counts on EADC saturation during ramp

### A.7.8 EADC Control Register (EADCCTRL)

Address 0x0008\_0020 – Front End Control 2 EADC Control Register

Address 0x000B\_0020 – Front End Control 1 EADC Control Register

Address 0x000E\_0020 – Front End Control 0 EADC Control Register

Bit Number	28	27	26
Bit Name	D2S_COMP_EN	EN_HYST_HIGH	EN_HYST_LOW
Access	R/W	R/W	R/W
Default	0	0	0

Bit Number	25:22	21	20
Bit Name	SAMP_TRIG_SCALE	FRAME_SYNC_EN	SCFE_CNT_RST
Access	R/W	R/W	R/W
Default	0000	0	0

Bit Number	19:16	15	14
Bit Name	SCFE_CNT_INIT	EADC_INV	AUTO_GAIN_SHIFT_MODE
Access	R/W	R/W	R/W
Default	0000	0	0

Bit Number	13	12	11
Bit Name	AUTO_GAIN_SHIFT_EN	AVG_WEIGHT_EN	AVG_SPATIAL_EN
Access	R/W	R/W	R/W
Default	0	0	0

Bit Number	10:9	8:6	5:4
Bit Name	AVG_MODE_SEL	EADC_MODE	AFE_GAIN
Access	R/W	R/W	R/W
Default	00	000	11

Bit Number	3	2	1	0
Bit Name	SCFE_GAIN_FILTER_SEL	SCFE_CLK_DIV_2	SCFE_ENA	EADC_ENA
Access	R/W	R/W	R/W	R/W
Default	1	1	1	1

**Bit 28: D2S\_COMP\_EN** – Analog Front End Ramp Comparator Enable

0 = Analog Front End Ramp Comparator disabled (Default)

1 = Analog Front End Ramp Comparator enabled

**Bit 27: EN\_HYST\_HIGH** – Increase comparator trip point by ~70mV

0 = Disables increase of ramp comparator trip point (Default)

1 = Enables increase of ramp comparator trip point

**Bit 26: EN\_HYST\_LOW** – Decrease comparator trip point by ~70mV

0 = Disables decrease of ramp comparator trip point (Default)

1 = Enables decrease of ramp comparator trip point

- Bits 25-22: SAMP\_TRIG\_SCALE** – Provides capability to mask incoming sample triggers to Front End Control
- 0 = EADC conversion initiated on every received sample trigger (Default)
  - 1 = EADC conversion initiated once every 2 received sample triggers
  - 2 = EADC conversion initiated once every 3 received sample triggers
  - .....
  - 15 = EADC conversion initiated once every 16 received sample triggers
- Bit 21: FRAME\_SYNC\_EN** – Enable synchronization of switched cap front end counter to Switching Cycle Frame boundary
- 0 = Switch Cap Front End Counter not synchronized to frame (Default)
  - 1 = Switch Cap Front End Counter synchronized to frame boundary
- Bit 20: SCFE\_CNT\_RST** – Force reset of Switched Cap Front End Counter
- 0 = Switch Cap Front End Counter operational (Default)
  - 1 = Switch Cap Front End Counter reset
- Bits 19-16: SCFE\_CNT\_INIT** – Configures initial Switched Cap Front End Counter value out of reset or at start of switching cycle in Peak Current mode
- Bit 15: EADC\_INV** – Enables EADC Data Inversion on data to filter module
- 0 = EADC Data is not inverted (Default)
  - 1 = EADC Data Inverted
- Bit 14: AUTO\_GAIN\_SHIFT\_MODE** – Configures Automatic Gain Shifting mode
- 0 = Fixed mode, gain shifting dependent on saturation of EADC for decreasing gain and less than 1/4 of dynamic range for increasing gain (Default)
  - 1 = NL mode, gain shifting dependent on Non-Linear limit thresholds
- Bit 13: AUTO\_GAIN\_SHIFT\_EN** – Enables Automatic Gain Shifting mode
- 0 = Automatic Gain Shifting Mode disabled (Default)
  - 1 = Automatic Gain Shifting Mode enabled
- Bit 12: AVG\_WEIGHT\_EN** – Enables weighted averaging in EADC averaging mode(**EADC\_MODE = 1**), only applicable in 4x and 8x averaging mode (**AVG\_MODE\_SEL = 1 or 2**). For 4x averaging, two oldest samples are each weighted by 1/8, the next oldest sample has a weight of 1/4 and the newest sample is weighted by 1/2. For 8x averaging, the four oldest samples are each weighted by 1/16, the next 2 oldest samples are weighted by 1/8, the next oldest sample is weighted by 1/4 and the newest sample is weighted by 1/4.
- 0 = Weighted averaging disabled (Default)
  - 1 = Weighted averaging enabled
- Bit 11: AVG\_SPATIAL\_EN** – Enables spatial mode in EADC averaging mode
- 0 = (Default)
  - For 2x averaging, Each sample trigger from DPWM triggers 2 EADC start of conversions.
  - For 4x averaging, Each sample trigger from DPWM triggers 4 EADC start of conversions.
  - For 8x averaging, Each sample trigger from DPWM triggers 8 EADC start of conversions.
  - For 2x, 4x and 8x averaging; Each sample trigger from DPWM results in a single averaged sample to filter.
  - 1 = EADC samples averaged based on received sample triggers from DPWM modules. Each sample trigger from DPWM triggers one EADC start of conversion.
  - For 2x averaging, 2 sample triggers from DPWM results in a single averaged sample to filter.
  - For 4x averaging, 4 sample triggers from DPWM results in a single averaged sample to filter.
  - For 8x averaging, 8 sample triggers from DPWM results in a single averaged sample to filter.
- Bit 10-9: AVG\_MODE\_SEL** – Averaging Mode Configuration
- 0 = 2x Averaging (Default)
  - 1 = 4x Averaging
  - 2 = 8x Averaging
- Bits 8-6: EADC\_MODE** – Selects EADC Mode Operation
- 0 = Standard mode, EADC samples based on sample triggers from DPWM module (Default)
  - 1 = Averaging Mode, configured by **AVG\_MODE\_SEL**
  - 2 = Non-continuous SAR Mode
  - 3 = Continuous SAR Mode
  - 4 = Reserved

- 5 = Peak Current Mode
- 6 = Constant Power/Constant Current Control Mode (CPCC module controls switching between Standard Mode and Non-Continuous SAR Mode)
- 7 = Constant Power/Constant Current Control 2 Mode (CPCC module controls switching between Standard mode and Continuous SAR Mode)

**Bits 5-4: AFE\_GAIN** – AFE Front End Gain Setting

- 0 = 1x Gain, 8mV/LSB
- 1 = 2x Gain, 4mV/LSB
- 2 = 4x Gain, 2mV/LSB
- 3 = 8x Gain, 1mV/LSB (Default)

**Bit 3: SCFE\_GAIN\_FILTER\_SEL** – Switched Cap Noise Filter Enable

- 0 = Disables Switch Cap Noise Filter
- 1 = Enables Switch Cap Noise Filter (Default)

**Bit 2: SCFE\_CLK\_DIV\_2** – Switched Cap Front End Clock Divider Select

- 0 = Switch Cap Clock divide by 2
- 1 = Switch Cap Clock divide by 1 (Default)

**Bit 1: SCFE\_ENA** – Switch Cap Front Enable

- 0 = Disables Switch Cap Front End logic
- 1 = Enables Switch Cap Front End logic (Default)

**Bit 0: EADC\_ENA** – EADC Enable

- 0 = Disables EADC
- 1 = Enables EADC (Default)



### A.7.9 Pre-Bias Control Register 0 (PREBIASCTRL0)

Address 0x0008\_0028 – Front End Control 2 Pre-Bias Control Register 0

Address 0x000B\_0028 – Front End Control 1 Pre-Bias Control Register 0

Address 0x000E\_0028 – Front End Control 0 Pre-Bias Control Register 0

Bit Number	17	16	15:8	7:0
Bit Name	PRE_BIAS_POL	PRE_BIAS_EN	PRE_BIAS_RANGE	PRE_BIAS_LIMIT
Access	R/W	R/W	R/W	R/W
Default	0	0	1111_1111	0000_0000

**Bit 17: PRE\_BIAS\_POL** – Configures polarity of received error voltage

0 = Error equals Vref-Vin (Default)

1 = Error equals Vin-Vref

**Bit 16: PRE\_BIAS\_EN** – Enable Pre-Biasing of Error ADC (Ramp should be disabled during pre-biasing, bit 0 of Ramp Control Register)

0 = Pre-Biasing has not been initiated (Default)

1 = Pre-Biasing by hardware has been enabled

**Bits 15-8: PRE\_BIAS\_RANGE** – Sets the acceptable range around the zero error point. If Error ADC value stays in range for number of samples specified by **PRE\_BIAS\_LIMIT** (Bits 7:0), **PREBIAS\_STATUS** (Bit 0) is enabled. Range will be +/- **PRE\_BIAS\_RANGE** around zero error point.

**Bits 7-0: PRE\_BIAS\_LIMIT** – Sets the acceptable number of samples in which the Error ADC value stays in range before asserting **PREBIAS\_STATUS** (Bit 0). Counter limit ranges from 0 to 255. If **PREBIAS\_STATUS** is set, it will take **PRE\_BIAS\_LIMIT** samples outside of acceptable range before clearing **PREBIAS\_STATUS**.

### A.7.10 Pre-Bias Control Register 1 (PREBIASCTRL1)

Address 0x0008\_002C – Front End Control 2 Pre-Bias Control Register 1

Address 0x000B\_002C – Front End Control 1 Pre-Bias Control Register 1

Address 0x000E\_002C – Front End Control 0 Pre-Bias Control Register 1

Bit Number	23:16	15:14	13:0
Bit Name	SAMPLES_PER_ADJ	RESERVED	MAX_DAC_ADJ
Access	R/W	-	R/W
Default	0000_0000	00	00_0000_0000_0000

**Bits 23-16: SAMPLES\_PER\_ADJ** – Configures the number of EADC samples between Pre-Bias DAC setpoint adjustments

0 = DAC Setpoint adjustment on each EADC sample

1 = DAC Setpoint adjustment after 2 EADC sample

2 = DAC Setpoint adjustment after 3 EADC samples

.....

255 = DAC Setpoint adjustment after 256 EADC samples

**Bits 15-14: RESERVED** – Unused Bits

**Bits 13-0: MAX\_DAC\_ADJ** – Configures the maximum DAC setpoint adjustment step

### A.7.11 SAR Control Register (SARCTRL)

Address 0x0008\_0030 – Front End Control 2 SAR Control Register

Address 0x000B\_0030 – Front End Control 1 SAR Control Register

**Address 0x000E\_0030 – Front End Control 0 SAR Control Register**

Bit Number	31:24	23:16	15:8
Bit Name	EADC_WINDOW_2	EADC_WINDOW_1	SAR_RANGE
Access	R/W	R/W	R/W
Default	0010_1000	0110_0000	0000_0000

Bit Number	7:2	1:0
Bit Name	RESERVED	SAR_RESOLUTION
Access	-	R/W
Default	0000_00	00

**Bits 31-24: EADC\_WINDOW\_2** – Configures acceptable range of error values (+/-) to transition to AFE Gain of 2 during SAR process

**Bits 23-16: EADC\_WINDOW\_1** – Configures acceptable range of error values (+/-) to transition to AFE Gain of 1 during SAR process

**Bits 15-8: SAR\_RANGE** – Configures acceptable range of error values(+/-) before declaring SAR completion

**Bits 7-2: RESERVED** – Unused bits

**Bits 1-0: SAR\_RESOLUTION** – Configures the final resolution for SAR Conversions

0 = 8mV Resolution, 1x AFE Gain

1 = 4mV Resolution, 2x AFE Gain

2 = 2mV Resolution, 4x AFE Gain

3 = 1mV Resolution, 8x AFE Gain

### A.7.12 SAR Timing Register (SARTIMING)

Address 0x0008\_0034 – Front End Control 2 SAR Timing Register

Address 0x000B\_0034 – Front End Control 1 SAR Timing Register

Address 0x000E\_0034 – Front End Control 0 SAR Timing Register

Bit Number	10:8	7
Bit Name	SAR_TIMING_UPPER	RESERVED
Access	R/W	-
Default	100	0

Bit Number	6:4	3	2:0
Bit Name	SAR_TIMING_MID	RESERVED	SAR_TIMING_LOWER
Access	R/W	-	R/W
Default	011	0	010

**Bits 10-8: SAR\_TIMING\_UPPER** – Configures timing for Bits 9:8 of DAC setpoint for SAR Algorithm

**Bit 7: RESERVED** – Unused bit

**Bits 6-4: SAR\_TIMING\_MID** – Configures timing for Bits 7:6 of DAC setpoint for SAR Algorithm

**Bit 3: RESERVED** – Unused bit

**Bits 2-0: SAR\_TIMING\_LOWER** – Configures timing for Bits 5:0 of DAC setpoint for SAR Algorithm

### A.7.13 EADC Value Register (EADCVALUE)

Address 0x0008\_0038 – Front End Control 2 EADC Value Register

Address 0x000B\_0038 – Front End Control 1 EADC Value Register

Address 0x000E\_0038 – Front End Control 0 EADC Value Register

Bit Number	25:16	15	14
Bit Name	ABS_VALUE	EADC_SAT_HIGH	EADC_SAT_LOW
Access	R	R	R
Default	-	-	-

Bit Number	13:9	8:0
Bit Name	RESERVED	ERROR_VALUE
Access	-	R
Default	00_000	-

**Bits 25-16: ABS\_VALUE** – 10-bit Absolute Value calculated by Front End Control Module with a resolution of 1.5625mV/bit

**Bit 15: EADC\_SAT\_HIGH** – EADC Saturation High Indicator

0 = EADC output is not saturated at high limit

1 = EADC output is saturated at high limit

**Bit 14: EADC\_SAT\_LOW** – EADC Saturation Low Indicator

0 = EADC output is not saturated at low limit

1 = EADC output is saturated at low limit

**Bits 13-9: RESERVED** – Unused bits

**Bits 8-0: ERROR\_VALUE** – Signed 9-bit Error value measured by Front End Control Module with a resolution of 1mV/bit

**A.7.14 EADC Raw Value Register (EADCRAWVALUE)**
*Address 0x0008\_003C – Front End Control 2 EADC Raw Value Register*
*Address 0x000B\_003C – Front End Control 1 EADC Raw Value Register*
*Address 0x000E\_003C – Front End Control 0 EADC Raw Value Register*

<b>Bit Number</b>	<b>8:0</b>
<b>Bit Name</b>	RAW_ERROR_VALUE
<b>Access</b>	R
<b>Default</b>	-

**Bits 8-0: RAW\_ERROR\_VALUE** – Signed 9-bit Error value measured by Front End Control Module with a resolution of 1mV/bit. Value is raw EADC data before averaging.

**A.7.15 DAC Status Register (DACSTAT)**
*Address 0x0008\_0040 – Front End Control 2 DAC Status Register*
*Address 0x000B\_0040 – Front End Control 1 DAC Status Register*
*Address 0x000E\_0040 – Front End Control 0 DAC Status Register*

<b>Bit Number</b>	<b>9:0</b>
<b>Bit Name</b>	DAC_VALUE
<b>Access</b>	R
<b>Default</b>	00_0000_0000

**Bits 9-0: DAC\_VALUE** – Current 10-bit Value sent to DAC

**A.7.16**

## A.8 Miscellaneous Analog Control

The Miscellaneous Analog Control module provides control signals to the oscillator and AFE blocks.

### A.8.1 Clock Trim Register (CLKTRIM) (For Factory Test Use Only)

Address FFF7F000

Bit Number	16	15:12	11:8	7:0
Bit Name	RESET_DISABLE	HFO_FINE_TRIM	HFO_COARSE_TRIM	RESERVED
Access	R/W	R/W	R/W	
Default	0	1000	0110	xx

#### Bits 16: RESET\_DISABLE

- 0 = Reset pin resets device (Default)
- 1 = Reset pin does not reset the device

**Bits 15-12: HFO\_FINE\_TRIM** - High Frequency Oscillator Clock Trim Bits. Register will be programmed during test and should not be overwritten by firmware

**Bits 11-8: HFO\_COARSE\_TRIM** - High Frequency Oscillator Clock Trim Bits. Register will be programmed during test and should not be overwritten by firmware

**Bits 7-0: RESERVED** – may be non-zero, should not be changed by firmware

### A.8.2 Package ID Register (PKGID)

Address FFF7F010

Bit Number	1:0
Bit Name	PKG_ID
Access	R/W
Default	00

**Bits 1-0: PKG\_ID** – Represents package type of device

- 0 = 64-pin package (Default)
- 1 = 40-pin package

### A.8.3 Brownout Register (BROWNOUT)

Address FFF7F014

Bit Number	2	1	0
Bit Name	INT	INT_EN	COMP_EN
Access	R	R/W	R/W
Default	-	0	0

**Bit 2: INT** – Brownout Interrupt Status

- 0 = No Brownout Condition observed
- 1 = Brownout Condition observed

**Bit 1: INT\_EN** – Brownout Interrupt Enable

- 0 = Brownout Interrupt disabled (Default)
- 1 = Brownout Interrupt enabled

**Bit 0: COMP\_EN** – Brownout Comparator Enable

- 0 = Brownout comparator logic disabled (Default)

---

1 = Brownout comparator logic enabled

#### A.8.4 Global I/O EN Register (GLBIOEN)

Address FFF7F018

<b>Bit Number</b>	<b>29:0</b>
<b>Bit Name</b>	GLOBAL_IO_EN
<b>Access</b>	R/W
<b>Default</b>	00_0000_0000_0000_0000_0000_0000_0000

**Bits 29-0: GLOBAL\_IO\_EN** – This register enables the global control of digital I/O pins  
 0 = Control of IO is done by the functional block assigned to the IO (Default)  
 1 = Control of IO is done by Global IO registers.

Bit assignment is done by this table:

<b>BIT</b>	<b>PIN_NAME</b>
29	FAULT[3]
28	ADC_EXT_TRIG
27	TCK
26	TDO
25	TMS
24	TDI
23	SCI_TX[1]
22	SCI_TX[0]
21	SCI_RX[1]
20	SCI_RX[0]
19	TMR_CAP
18	TMR_PWM[1]
17	TMR_PWM[0]
16	PMBUS-CLK
15	PMBUS-DATA
14	CONTROL
13	ALERT
12	EXT_INT
11	FAULT[2]
10	FAULT[1]
9	FAULT[0]
8	SYNC
7	DPWM4B
6	DPWM4A
5	DPWM3B
4	DPWM3A
3	DPWM2B
2	DPWM2A
1	DPWM1B
0	DPWM1A

### A.8.5 Global I/O OE Register (GLBIOOE)

Address FFF7F01C

Bit Number	29:0
Bit Name	GLOBAL_IO_OE
Access	R/W
Default	00_0000_0000_0000_0000_0000_0000_0000

**Bits 29-0: GLOBAL\_IO\_OE** – This register controls the output enable signals for all digital I/O pins  
 0 = Input (Default)  
 1 = Output

Bit assignment is done by this table:

BIT	PIN_NAME
29	FAULT[3]
28	ADC_EXT_TRIG
27	TCK
26	TDO
25	TMS
24	TDI
23	SCI_TX[1]
22	SCI_TX[0]
21	SCI_RX[1]
20	SCI_RX[0]
19	TMR_CAP
18	TMR_PWM[1]
17	TMR_PWM[0]
16	PMBUS-CLK
15	PMBUS-DATA
14	CONTROL
13	ALERT
12	EXT_INT
11	FAULT[2]
10	FAULT[1]
9	FAULT[0]
8	SYNC
7	DPWM4B
6	DPWM4A
5	DPWM3B
4	DPWM3A
3	DPWM2B
2	DPWM2A
1	DPWM1B
0	DPWM1A



### A.8.6 Global I/O Open Drain Control Register (GLBLOOD)

Address FFF7F020

Bit Number	29:0
Bit Name	GLOBAL_IO_OD
Access	R/W
Default	00_0000_0000_0000_0000_0000_0000_0000

**Bits 29-0: GLOBAL\_IO\_OD** – This register controls if the global IO is configured as an open drain. This bit multiplexes the GLOBAL\_IO\_VALUE register to the OE signals

0 = Normal I/O (Default)

1 = Open Drain

Bit assignment is done by this table:

BIT	PIN_NAME
29	FAULT[3]
28	ADC_EXT_TRIG
27	TCK
26	TDO
25	TMS
24	TDI
23	SCI_TX[1]
22	SCI_TX[0]
21	SCI_RX[1]
20	SCI_RX[0]
19	TMR_CAP
18	TMR_PWM[1]
17	TMR_PWM[0]
16	PMBUS-CLK
15	PMBUS-DATA
14	CONTROL
13	ALERT
12	EXT_INT
11	FAULT[2]
10	FAULT[1]
9	FAULT[0]
8	SYNC
7	DPWM4B
6	DPWM4A
5	DPWM3B
4	DPWM3A
3	DPWM2B
2	DPWM2A
1	DPWM1B
0	DPWM1A

### A.8.7 Global I/O Value Register (GLBIOVAL)

Address FFF7F024

Bit Number	29:0
Bit Name	GLOBAL_IO_VALUE
Access	R/W
Default	00_0000_0000_0000_0000_0000_0000_0000

**Bits 29-0: GLOBAL\_IO\_VALUE** – This register set the output value of the digital I/O pins when configured as outputs

0 = Digital I/O pin configured as low in output mode (Default)

1 = Digital I/O pin configured as high in output mode

Bit assignment is done by this table:

BIT	PIN_NAME
29	FAULT[3]
28	ADC_EXT_TRIG
27	TCK
26	TDO
25	TMS
24	TDI
23	SCI_TX[1]
22	SCI_TX[0]
21	SCI_RX[1]
20	SCI_RX[0]
19	TMR_CAP
18	TMR_PWM[1]
17	TMR_PWM[0]
16	PMBUS-CLK
15	PMBUS-DATA
14	CONTROL
13	ALERT
12	EXT_INT
11	FAULT[2]
10	FAULT[1]
9	FAULT[0]
8	SYNC
7	DPWM4B
6	DPWM4A
5	DPWM3B
4	DPWM3A
3	DPWM2B
2	DPWM2A
1	DPWM1B
0	DPWM1A

### A.8.8 Global I/O Read Register (GLBIOREAD)

Address FFF7F028

<b>Bit Number</b>	<b>29:0</b>
<b>Bit Name</b>	GLOBAL_IO_READ
<b>Access</b>	R
<b>Default</b>	-

**Bits 29-0: GLOBAL\_IO\_READ** – This register provides the value on these signals after I/O muxing  
 0 = Digital I/O pin low (Default)  
 1 = Digital I/O pin high

Bit assignment is done by this table:

<b>BIT</b>	<b>PIN_NAME</b>
29	FAULT[3]
28	ADC_EXT_TRIG
27	TCK
26	TDO
25	TMS
24	TDI
23	SCI_TX[1]
22	SCI_TX[0]
21	SCI_RX[1]
20	SCI_RX[0]
19	TMR_CAP
18	TMR_PWM[1]
17	TMR_PWM[0]
16	PMBUS-CLK
15	PMBUS-DATA
14	CONTROL
13	ALERT
12	EXT_INT
11	FAULT[2]
10	FAULT[1]
9	FAULT[0]
8	SYNC
7	DPWM4B
6	DPWM4A
5	DPWM3B
4	DPWM3A
3	DPWM2B
2	DPWM2A
1	DPWM1B
0	DPWM1A

#### **A.8.9 Temp Sensor Control Register (TEMPSENCTRL)**

**Address FFF7F02C**

#### **A.8.10 I/O Mux Control Register (IOMUX)**

**Address FFF7F030**

Bit Number	13	12	11	11
Bit Name	DTC_B_SEL	DTC_A_SEL	UART1_RX_SEL	UART0_RX_SEL
Access	R/W	R/W	R/W	R/W
Default	0	0	0	0

Bit Number	9:8	7:6	5:4
Bit Name	EXT_TRIG_MUX_SEL	JTAG_CLK_MUX_SEL	JTAG_DATA_MUX_SEL
Access	R/W	R/W	R/W
Default	00	10	00

Bit Number	3:2	1	0
Bit Name	SYNC_MUX_SEL	UART_MUX_SEL	PMBUS_MUX_SEL
Access	R/W	R/W	R/W
Default	00	0	0

- Bit 13: DTC\_B\_SEL** – DTC Phase-B Pin Mux Select  
 0 = DTC Phase-B input from TDO pin  
 1 = DTC Phase-B input from SYNC pin
- Bit 12: DTC\_A\_SEL** – DTC Phase-A Pin Mux Select  
 0 = DTC Phase-A input from TDI pin  
 1 = DTC Phase-A input from TCK pin
- Bit 11: UART1\_RX\_SEL** – UART 1 RX Mux  
 0 = UART 1 RX input from UART 1 RX pin  
 1 = UART 1 RX input from UART 0 RX pin
- Bit 10: UART0\_RX\_SEL** – UART 0 RX Mux  
 0 = UART 0 RX input from UART 0 RX pin  
 1 = UART 0 RX input from UART 1 RX pin

**Bits 9-8: EXT\_TRIG\_MUX\_SEL** – EXT\_TRIG Pin Mux Select

I/O Pin	0	1	2	3
EXT_TRIG	EXT_TRIG	TCAP	SYNC	PWM-0

**Bits 7-6: JTAG\_CLK\_MUX\_SEL** – TCK Pin Mux Select

I/O Pin	0	1	2	3
TCK	TCK	TCAP	SYNC	PWM-0

**Bits 5-4: JTAG\_DATA\_MUX\_SEL** – TDO/TDI Pin Mux Select

I/O Pin	0	1	2	3
TDO	TDO	SCI_TX-0	ALERT	FAULT-0
TDI	TDI	SCI_RX-0	CONTROL	FAULT-1

**Bits 3-2: SYNC\_MUX\_SEL** – SYNC Pin Mux Select

I/O Pin	0	1	2	3
SYNC	SYNC	TCAP	EXT_TRIG	PWM-0

**Bit 1: UART\_MUX\_SEL** – SCL/SDA Pins Mux Select

I/O Pin	0	1
SCI_TX-1	SCI_TX-1	ALERT
SCI_RX-1	SCI_RX-1	CONTROL

**Bit 0: PMBUS\_MUX\_SEL** – SCL/SDA Pins Mux Select

I/O Pin	0	1
SCL	SCL	SCI_TX-0
SDA	SDA	SCI_RX-0

### A.8.11 Current Sharing Control Register (CSCTRL)

Address FFF7F038

Bit Number	23:16	15:8	7:4	3:0
Bit Name	DPWM_DUTY	DPWM_PERIOD	RESERVED	TEST_MODE
Access	R/W	R/W	-	R/W
Default	0000_0000	0000_0000	0000	0000

**Bits 23-16: DPWM\_DUTY** – Configures Pulse Width/Duty Cycle for DPWM output to Current Sharing circuit. Resolution of LSB equals period of MCLK clock

**Bits 15-8: DPWM\_PERIOD** – Configures Period for DPWM output to Current Sharing circuit. Output period equals DPWM\_PERIOD+1 \* LSB resolution. Resolution of LSB equals period of MCLK clock

**Bits 7-4: RESERVED** – Unused bits

**Bits 3-0: TEST\_MODE** – Controls Current Sharing Operation

Test Mode	EN_SW1	EN_SW2	DIS_RES	DPWM	EN_HALF_CURR
0000	0	0	1	0	0
0001	1	0	0	ACTIVE	0
0010	0	0	1	0	0
0011	0	1	1	0	0
01XX	1	0	1	1	0
10XX	0	0	0	0	0
11XX	1	0	0	1	1

### A.8.12 Temperature Reference Register (TEMPREF)

Address FFF7F03C

Bit Number	11:0
Bit Name	TEMP_REF
Access	R/W
Default	0000_0000_0000

**Bits 11-0: TEMP\_REF** – Reference measurement taken during factory trim, ADC12 measurement of the internal temperature sensor at room temperature for use in offset calibration

**A.8.13 Power Disable Control Register (PWRDISCTRL)**

Address FFF7F040

Bit Number	17	16	15
Bit Name	PCM_CLK_EN	CPCC_CLK_EN	FILTER2_CLK_EN
Access	R/W	R/W	R/W
Default	1	1	1

Bit Number	14	13	12	11
Bit Name	FILTER1_CLK_EN	FILTER0_CLK_EN	FE_CTRL2_CLK_EN	FE_CTRL1_CLK_EN
Access	R/W	R/W	R/W	R/W
Default	1	1	1	1

Bit Number	10	9	8
Bit Name	FE_CTRL0_CLK_EN	DPWM3_CLK_EN	DPWM2_CLK_EN
Access	R/W	R/W	R/W
Default	1	1	1

Bit Number	7	6	5	4
Bit Name	DPWM1_CLK_EN	DPWM0_CLK_EN	SCI1_CLK_EN	SCI0_CLK_EN
Access	R/W	R/W	R/W	R/W
Default	1	1	1	1

Bit Number	3	2	1	0
Bit Name	ADC12_CLK_EN	PMBUS_CLK_EN	GIO_CLK_EN	TIMER_CLK_EN
Access	R/W	R/W	R/W	R/W
Default	1	1	1	1

**Bit 17: PCM\_CLK\_EN** – Clock Enable for Digital Peak Current Control Module

0 = Disables clocks to Digital Peak Current Control Module

1 = Enables clocks to Digital Peak Current Control Module (Default)

**Bit 16: CPCC\_CLK\_EN** – Clock Enable for Constant Power/Constant Current Module

0 = Disables clocks to Constant Power/Constant Current Module

1 = Enables clocks to Constant Power/Constant Current Module (Default)

**Bit 15: FILTER2\_CLK\_EN** – Clock Enable for Filter 2 Module

0 = Disables clocks to Filter 2 Module

1 = Enables clocks to Filter 2 Module (Default)

**Bit 14: FILTER1\_CLK\_EN** – Clock Enable for Filter 1 Module

0 = Disables clocks to Filter 1 Module

1 = Enables clocks to Filter 1 Module (Default)

**Bit 13: FILTER0\_CLK\_EN** – Clock Enable for Filter 0 Module

0 = Disables clocks to Filter 0 Module

1 = Enables clocks to Filter 0 Module (Default)

**Bit 12: FE\_CTRL2\_CLK\_EN** – Clock Enable for Front End Control 2 Module

0 = Disables clocks to Front End Control 2 Module

1 = Enables clocks to Front End Control 2 Module (Default)

**Bit 11: FE\_CTRL1\_CLK\_EN** – Clock Enable for Front End Control 1 Module

0 = Disables clocks to Front End Control 1 Module

- 1 = Enables clocks to Front End Control 1 Module (Default)  
**Bit 10: FE\_CTRL0\_CLK\_EN** – Clock Enable for Front End Control 0 Module  
0 = Disables clocks to Front End Control 0 Module  
1 = Enables clocks to Front End Control 0 Module (Default)  
**Bit 9: DPWM3\_CLK\_EN** – Clock Enable for DPWM 3 Module  
0 = Disables clocks to DPWM 3 Module  
1 = Enables clocks to DPWM 3 Module (Default)  
**Bit 8: DPWM2\_CLK\_EN** – Clock Enable for DPWM 2 Module  
0 = Disables clocks to DPWM 2 Module  
1 = Enables clocks to DPWM 2 Module (Default)  
**Bit 7: DPWM1\_CLK\_EN** – Clock Enable for DPWM 1 Module  
0 = Disables clocks to DPWM 1 Module  
1 = Enables clocks to DPWM 1 Module (Default)  
**Bit 6: DPWM0\_CLK\_EN** – Clock Enable for DPWM 0 Module  
0 = Disables clocks to DPWM 0 Module  
1 = Enables clocks to DPWM 0 Module (Default)  
**Bit 5: SCI1\_CLK\_EN** – Clock Enable for SCI/UART 1 Module  
0 = Disables clocks to SCI/UART 1 Module  
1 = Enables clocks to SCI/UART 1 Module (Default)  
**Bit 4: SCI0\_CLK\_EN** – Clock Enable for SCI/UART 0 Module  
0 = Disables clocks to SCI/UART 0 Module  
1 = Enables clocks to SCI/UART 0 Module (Default)  
**Bit 3: ADC12\_CLK\_EN** – Clock Enable for ADC12 Control Module  
0 = Disables clocks to ADC12 Control Module  
1 = Enables clocks to ADC12 Control Module (Default)  
**Bit 2: PMBUS\_CLK\_EN** – Clock Enable for PMBus Interface Module  
0 = Disables clocks to PMBus Interface Module  
1 = Enables clocks to PMBus Interface Module (Default)  
**Bit 1: GIO\_CLK\_EN** – Clock Enable for GIO Module  
0 = Disables clocks to GIO Module  
1 = Enables clocks to GIO Module (Default)  
**Bit 0: TIMER\_CLK\_EN** – Clock Enable for Timer Module  
0 = Disables clocks to Timer Module  
1 = Enables clocks to Timer Module (Default)



**PMBus Interface**
**A.8.14 PMBUS Control Register 1 (PMBCTRL1)**
**Address FFF7F600**

Bit Number	20	19	18	17
Bit Name	PRC_CALL	GRP_CMD	PEC_ENA	EXT_CMD
Access	R/W	R/W	R/W	R/W
Default	0	0	0	0

Bit Number	16	15:8	7:1	0
Bit Name	CMD_ENA	BYTE_COUNT	SLAVE_ADDR	RW
Access	R/W	R/W	R/W	R/W
Default	0	0000_0000	000_0000	0

**Bit 20: PRC\_CALL** – Master Process Call Message Enable

0 = Default state for all messages besides Process Call message (Default)

1 = Enables transmission of Process Call message

**Bit 19: GRP\_CMD** – Master Group Command Message Enable

0 = Default state for all messages besides Group Command message (Default)

1 = Enables transmission of Group Command message

**Bit 18: PEC\_ENA** – Master PEC Processing Enable

0 = Disables PEC processing (Default)

1 = Enables PEC byte transmission/reception

**Bit 17: EXT\_CMD** – Master Extended Command Code Enable

0 = Use 1 byte for Command Code (Default)

1 = Use 2 bytes for Command Code

**Bit 16: CMD\_ENA** – Master Command Code Enable

0 = Disables use of command code on Master initiated messages (Default)

1 = Enables use of command code on Master initiated messages

**Bits 15-8: BYTE\_COUNT** – Indicates number of data bytes transmitted in current message. Byte count does not include any device addresses, command words or block lengths in block messages. In block messages, the PMBus Interface automatically inserts the block length into the message based on the byte count setting. The firmware only needs to load the address, command words and data to be transmitted. PMBus Interface supports byte writes up to 255 bytes.

**Bits 7-1: SLAVE\_ADDR** – Specifies the address of the slave to which the current message is directed towards.

**Bit 0: RW** – Indicates if current Master initiated message is read operation or write operation.

0 = Message is a write transaction (data from Master to Slave) (Default)

1 = Message is a read transaction (data from Slave to Master)

### A.8.15 PMBus Transmit Data Buffer (PMBTXBUF)

Address FFF7F604

Bit Number	31:24	23:16	15:8	7:0
Bit Name	BYTE3	BYTE2	BYTE1	BYTE0
Access	R/W	R/W	R/W	R/W
Default	0000_0000	0000_0000	0000_0000	0000_0000

**Bits 31-24: BYTE3** – Last data byte transmitted from Transmit Data Buffer

**Bits 23-16: BYTE2** – Third data byte transmitted from Transmit Data Buffer

**Bits 15-8: BYTE1** – Second data byte transmitted from Transmit Data Buffer

**Bits 7-0: BYTE0** – First data byte transmitted from Transmit Data Buffer

### A.8.16 PMBus Receive Data Register (PMBRXBUF)

Address FFF7F608

Bit Number	31:24	23:16	15:8	7:0
Bit Name	BYTE3	BYTE2	BYTE1	BYTE0
Access	R	R	R	R
Default	-	-	-	-

**Bits 31-24: BYTE3** – Last data byte received in Receive Data Buffer

**Bits 23-16: BYTE2** – Third data byte received in Receive Data Buffer

**Bits 15-8: BYTE1** – Second data byte received in Receive Data Buffer

**Bits 7-0: BYTE0** – First data byte received in Receive Data Buffer

### A.8.17 PMBus Acknowledge Register (PMBACK)

Address FFF7F60C

Bit Number	0
Bit Name	ACK
Access	R/W
Default	0

**Bit 0: ACK** – Allows firmware to acknowledge or not acknowledge received data

0 = NACK received data (Default)

1 = Acknowledge received data, bit clears upon issue of ACK on PMBus

**A.8.18 PMBus Status Register (PMBST)**

Address FFF7F610

Bit Number	21	20	19	18
Bit Name	SCL_RAW	SDA_RAW	CONTROL_RAW	ALERT_RAW
Access	R	R	R	R
Default	-	-	-	-

Bit Number	17	16	15
Bit Name	CONTROL_EDGE	ALERT_EDGE	MASTER
Access	R	R	R
Default	-	-	-

Bit Number	14	13	12	11	10
Bit Name	LOST_ARB	BUS_FREE	UNIT_BUSY	RPT_START	SLAVE_ADDR_READY
Access	R	R	R	R	R
Default	-	-	-	-	-

Bit Number	9	8	7	6
Bit Name	CLK_HIGH_DETECTED	CLK_LOW_TIMEOUT	PEC_VALID	NACK
Access	R	R	R	R
Default	-	-	-	-

Bit Number	5	4	3	2:0
Bit Name	EOM	DATA_REQUEST	DATA_READY	RD_BYTE_COUNT
Access	R	R	R	R
Default	-	-	-	-

**Bit 21: SCL\_RAW** – PMBus Clock Pin Real Time Status

0 = PMBus clock pin observed at logic level low

1 = PMBus clock pin observed at logic level high

**Bit 20: SDA\_RAW** – PMBus Data Pin Real Time Status

0 = PMBus data pin observed at logic level low

1 = PMBus data pin observed at logic level high

**Bit 19: CONTROL\_RAW** – Control Pin Real Time Status

0 = Control pin observed at logic level low

1 = Control pin observed at logic level high

**Bit 18: ALERT\_RAW** – Alert Pin Real Time Status

0 = Alert pin observed at logic level low

1 = Alert pin observed at logic level high

**Bit 17: CONTROL\_EDGE** – Control Edge Detection Status

0 = Control pin has not transitioned

1 = Control pin has been asserted by another device on PMBus

**Bit 16: ALERT\_EDGE** – Alert Edge Detection Status

0 = Alert pin has not transitioned

1 = Alert pin has been asserted by another device on PMBus

**Bit 15: MASTER** – Master Indicator

0 = PMBus Interface in Slave Mode or Idle Mode

- 1 = PMBus Interface in Master Mode
- Bit 14: LOST\_ARB** – Lost Arbitration Flag
  - 0 = Master has attained control of PMBus
  - 1 = Master has lost arbitration and control of PMBus
- Bit 13: BUS\_FREE** – PMBus Free Indicator
  - 0 = PMBus processing current message
  - 1 = PMBus available for new message
- Bit 12: UNIT\_BUSY** – PMBus Busy Indicator
  - 0 = PMBus Interface is idle, ready to transmit/receive message
  - 1 = PMBus Interface is busy, processing current message
- Bit 11: RPT\_START** – Repeated Start Flag
  - 0 = No Repeated Start received by interface
  - 1 = Repeated Start condition received by interface
- Bit 10: SLAVE\_ADDR\_READY** – Slave Address Ready
  - 0 = Indicates no slave address is available for reading
  - 1 = Slave address ready to be read from Receive Data Register (Bits 6:0)
- Bit 9: CLK\_HIGH\_DETECTED** – Clock High Detection Status
  - 0 = No Clock High condition detected
  - 1 = Clock High exceeded 50us during message
- Bit 8: CLK\_LOW\_TIMEOUT** – Clock Low Timeout Status
  - 0 = No clock low timeout detected
  - 1 = Clock low timeout detected, clock held low for greater than 35ms
- Bit 7: PEC\_VALID** – PEC Valid Indicator
  - 0 = Received PEC not valid (if EOM is asserted)
  - 1 = Received PEC is valid
- Bit 6: NACK** – Not Acknowledge Flag Status
  - 0 = Data transmitted has been accepted by receiver
  - 1 = Receiver has not accepted transmitted data
- Bit 5: EOM** – End of Message Indicator
  - 0 = Message still in progress or PMBus in idle state.
  - 1 = End of current message detected
- Bit 4: DATA\_REQUEST** – Data Request Flag
  - 0 = No data needed by PMBus Interface
  - 1 = PMBus Interface request additional data. PMBus clock stretching enabled to stall bus until firmware provides transmit data.
- Bit 3: DATA\_READY** – Data Ready Flag
  - 0 = No data available for reading by processor
  - 1 = PMBus Interface read buffer full, firmware required to read data prior to further bus activity. PMBus clock stretching enabled to stall bus until data is read by firmware.
- Bits 2-0: RD\_BYTE\_COUNT** – Number of Data Bytes available in Receive Data Register
  - 0 = No received data
  - 1 = 1 byte received. Data located in Receive Data Register, Bits 7-0
  - 2 = 2 bytes received. Data located in Receive Data Register, Bits 15-0
  - 3 = 3 bytes received. Data located in Receive Data Register, Bits 23-0
  - 4 = 4 bytes received. Data located in Receive Data Register, Bits 31-0

**A.8.19 PMBus Interrupt Mask Register (PMBINTM)**

Address FFF7F614

Bit Number	9	8	7	6
Bit Name	CLK_HIGH_TIMEOUT	LOST_ARB	CONTROL	ALERT
Access	R/W	R/W	R/W	R/W
Default	1	1	1	1

Bit Number	5	4	3
Bit Name	EOM	SLAVE_ADDR_READY	DATA_REQUEST
Access	R/W	R/W	R/W
Default	1	1	1

Bit Number	2	1	0
Bit Name	DATA_READY	BUS_LOW_TIMEOUT	BUS_FREE
Access	R/W	R/W	R/W
Default	1	1	1

**Bit 9: CLK\_HIGH\_TIMEOUT** – Clock High Timeout Interrupt Mask

0 = Generates interrupt if clock high exceeds 50us during message

1 = Disables interrupt generation for Clock High timeout (Default)

**Bit 8: LOST\_ARB** – Lost Arbitration Interrupt Mask

0 = Generates interrupt upon assertion of Lost Arbitration flag

1 = Disables interrupt generation upon assertion of Lost Arbitration flag (Default)

**Bit 7: CONTROL** – Control Detection Interrupt Mask

0 = Generates interrupt upon assertion of Control flag

1 = Disables interrupt generation upon assertion of Control flag (Default)

**Bit 6: ALERT** – Alert Detection Interrupt Mask

0 = Generates interrupt upon assertion of Alert flag

1 = Disables interrupt generation upon assertion of Alert flag (Default)

**Bit 5: EOM** – End of Message Interrupt Mask

0 = Generates interrupt upon assertion of End of Message flag

1 = Disables interrupt generation upon assertion of End of Message flag (Default)

**Bit 4: SLAVE\_ADDR\_READY** – Slave Address Ready Interrupt Mask

0 = Generates interrupt upon assertion of Slave Address Ready flag

1 = Disables interrupt generation upon assertion of Slave Address Ready flag (Default)

**Bit 3: DATA\_REQUEST** – Data Request Interrupt Mask

0 = Generates interrupt upon assertion of Data Request flag

1 = Disables interrupt generation upon assertion of Data Request flag (Default)

**Bit 2: DATA\_READY** – Data Ready Interrupt Mask

0 = Generates interrupt upon assertion of Data Ready flag

1 = Disables interrupt generation upon assertion of Data Ready flag (Default)

**Bit 1: BUS\_LOW\_TIMEOUT** – Clock Low Timeout Interrupt Mask

0 = Generates interrupt upon assertion of Clock Low Timeout flag

1 = Disables interrupt generation upon assertion of Clock Low Timeout flag (Default)

**Bit 0: BUS\_FREE** – Bus Free Interrupt Mask

0 = Generates interrupt upon assertion of Bus Free flag

1 = Disables interrupt generation upon assertion of Bus Free flag (Default)

**A.8.20 PMBus Control Register 2 (PMBCTRL2)**

Address FFF7F618

Bit Number	22:21	20	19	18:16
Bit Name	RX_BYTE_ACK_CNT	MAN_CMD	TX_PEC	TX_COUNT
Access	R/W	R/W	R/W	R/W
Default	11	0	0	000

Bit Number	15	14:8	7	6:0
Bit Name	PEC_ENA	SLAVE_MASK	MAN_SLAVE_ACK	SLAVE_ADDR

Access	R/W	R/W	R/W	R/W
Default	0	111_1111	0	111_1100

**Bit 22-21: RX\_BYTE\_ACK\_CNT** – Configures number of data bytes to automatically acknowledge when receiving data in slave mode.

00 = 1 byte received by slave. Firmware is required to manually acknowledge every received byte.

01 = 2 bytes received by slave. Hardware automatically acknowledges the first received byte. Firmware is required to manually acknowledge after the second received byte.

10 = 3 bytes received by slave. Hardware automatically acknowledges the first 2 received bytes. Firmware is required to manually acknowledge after the third received byte.

11 = 4 bytes received by slave. Hardware automatically acknowledges the first 3 received bytes. Firmware is required to manually acknowledge after the fourth received byte (Default)

**Bit 20: MAN\_CMD** – Manual Command Acknowledgement Mode

0 = Slave automatically acknowledges received command code (Default)

1 = Data Request flag generated after receipt of command code, firmware required to issue ACK to continue message

**Bit 19: TX\_PEC** – Asserted when the slave needs to send a PEC byte at end of message. PMBus Interface will transmit the calculated PEC byte after transmitting the number of data bytes indicated by TX Byte Cnt(Bits 19:17).

0 = No PEC byte transmitted (Default)

1 = PEC byte transmitted at end of current message

**Bit 18-16: TX\_COUNT**– Number of valid bytes in Transmit Data Register

0 = No bytes valid (Default)

1 = One byte valid, Byte #0 (Bits 7:0 of Receive Data Register)

2 = Two bytes valid, Bytes #0 and #1 (Bits 15:0 of Receive Data Register)

3 = Three bytes valid, Bytes #0-2 (Bits 23:0 of Receive Data Register)

4 = Four bytes valid, Bytes #0-3 (Bits 31:0 of Receive Data Register)

**Bit 15: PEC\_ENA** – PEC Processing Enable

0 = PEC processing disabled (Default)

1 = PEC processing enabled

**Bit 14-8: SLAVE\_MASK** – Used in address detection, the slave mask enables acknowledgement of multiple device addresses by the slave. Writing a ‘0’ to a bit within the slave mask enables the corresponding bit in the slave address to be either ‘1’ or ‘0’ and still allow for a match. Writing a ‘0’ to all bits in the mask enables the PMBus Interface to acknowledge any device address. Upon power-up, the slave mask defaults to 7Fh, indicating the slave will only acknowledge the address programmed into the Slave Address (Bits 6-0).

**Bit 7: MAN\_SLAVE\_ACK**– Manual Slave Address Acknowledgement Mode

0 = Slave automatically acknowledges device address specified in SLAVE\_ADDR, Bits 6-0 (Default)

1 = Enables the Manual Slave Address Acknowledgement Mode. Firmware is required to read received address and acknowledge on every message

**Bits 6-0: SLAVE\_ADDR** – Configures the current device address of the slave. Used in automatic slave address acknowledge mode (default mode). The PMBus Interface will compare the received device address with the value stored in the Slave Address bits and the mask configured in the Slave Mask bits. If matching, the slave will acknowledge the device address.

### **A.8.21 PMBus Hold Slave Address Register (PMBHSA)**

**Address FFF7F61C**

Bit Number	7:1	0
Bit Name	SLAVE_ADDR	SLAVE_RW
Access	R	R
Default	-	-

**Bits 7-1: SLAVE\_ADDR** – Stored device address acknowledged by the slave

**Bit 0: SLAVE\_RW** – Stored R/W bit from address acknowledged by the slave

0 = Write Access

1 = Read Access

### A.8.22 PMBus Control Register 3 (PMBCTRL3)

Address FFF7F620

Bit Number	25	24:23
Bit Name	CLK_HI_EN	Reserved
Access	R/W	R/W
Default	0	0

Bit Number	22	21	20	19	18
Bit Name	MASTER_EN	SLAVE_EN	CLK_LO_DIS	IBIAS_B_EN	IBIAS_A_EN
Access	R/W	R/W	R/W	R/W	R/W
Default	0	1	0	0	0

Bit Number	17	16	15	14	13
Bit Name	SCL_DIR	SCL_VALUE	SCL_MODE	SDA_DIR	SDA_VALUE
Access	R/W	R/W	R/W	R/W	R/W
Default	0	0	0	0	0

Bit Number	12	11	10	9
Bit Name	SDA_MODE	CNTL_DIR	CNTL_VALUE	CNTL_MODE
Access	R/W	R/W	R/W	R/W
Default	0	0	0	0

Bit Number	8	7	6	5
Bit Name	ALERT_DIR	ALERT_VALUE	ALERT_MODE	CNTL_INT_EDGE
Access	R/W	R/W	R/W	R/W
Default	0	0	0	0

Bit Number	4	3	2	1	0
Bit Name	FAST_MODE_PLUS	FAST_MODE	BUS_LO_INT_EDGE	ALERT_EN	RESET
Access	R/W	R/W	R/W	R/W	R/W
Default	0	0	0	0	0

**Bit 25: CLK\_HI\_EN** – PMBus Clock High Timeout Enable

0 = PMBus Clock High Timeout disabled (Default)

1 = PMBus Clock High Timeout enabled

**Bit 24-23: Reserved** – Unused Bits

**Bit 22: MASTER\_EN** – PMBus Master Enable

0 = Disables PMBus Master capability (Default)

1 = Enables PMBus Master capability

**Bit 21: SLAVE\_EN** – PMBus Slave Enable

0 = Disables PMBus Slave capability

1 = Enables PMBus Slave capability (Default)

**Bit 20: CLK\_LO\_DIS** – Clock Low Timeout Disable

0 = Clock Low Timeout Enabled (Default)

1 = Clock Low Timeout Disabled



- Bit 19: IBIAS\_B\_EN** – PMBus Current Source B Control  
 0 = Disables Current Source for PMBUS address detection thru ADC (Default)  
 1 = Enables Current Source for PMBUS address detection thru ADC
- Bit 18: IBIAS\_A\_EN** – PMBus Current Source A Control  
 0 = Disables Current Source for PMBUS address detection thru ADC (Default)  
 1 = Enables Current Source for PMBUS address detection thru ADC
- Bit 17: SCL\_DIR** – Configures direction of PMBus clock pin in GPIO mode  
 0 = PMBus clock pin configured as output (Default)  
 1 = PMBus clock pin configured as input
- Bit 16: SCL\_VALUE** – Configures output value of PMBus clock pin in GPIO Mode  
 0 = PMBus clock pin driven low in GPIO Mode (Default)  
 1 = PMBus clock pin driven high in GPIO Mode
- Bit 15: SCL\_MODE** – Configures mode of PMBus Clock pin  
 0 = PMBus clock pin configured in functional mode (Default)  
 1 = PMBus clock pin configured as GPIO
- Bit 14: SDA\_DIR** – Configures direction of PMBus data pin in GPIO mode  
 0 = PMBus data pin configured as output (Default)  
 1 = PMBus data pin configured as input
- Bit 13: SDA\_VALUE** – Configures output value of PMBus data pin in GPIO Mode  
 0 = PMBus data pin driven low in GPIO Mode (Default)  
 1 = PMBus data pin driven high in GPIO Mode
- Bit 12: SDA\_MODE** – Configures mode of PMBus Data pin  
 0 = PMBus data pin configured in functional mode (Default)  
 1 = PMBus data pin configured as GPIO
- Bit 11: CNTL\_DIR** – Configures direction of Control pin in GPIO mode  
 0 = Control pin configured as output (Default)  
 1 = Control pin configured as input
- Bit 10: CNTL\_VALUE** – Configures output value of Control pin in GPIO Mode  
 0 = Control pin driven low in GPIO Mode (Default)  
 1 = Control pin driven high in GPIO Mode
- Bit 9: CNTL\_MODE** – Configures mode of Control pin  
 0 = Control pin configured in functional mode (Default)  
 1 = Control pin configured as GPIO
- Bit 8: ALERT\_DIR** – Configures direction of Alert pin in GPIO mode  
 0 = Control pin configured as output (Default)  
 1 = Control pin configured as input
- Bit 7: ALERT\_VALUE** – Configures output value of Alert pin in GPIO Mode  
 0 = Alert pin driven low in GPIO Mode (Default)  
 1 = Alert pin driven high in GPIO Mode
- Bit 6: ALERT\_MODE** – Configures mode of Alert pin  
 0 = Alert pin configured in functional mode (Default)  
 1 = Aler3 pin configured as GPIO
- Bit 5: CNTL\_INT\_EDGE** – Control Interrupt Edge Select  
 0 = Interrupt generated on falling edge of Control (Default)  
 1 = Interrupt generated on rising edge of Control
- Bit 4: FAST\_MODE\_PLUS** – Fast Mode Plus Enable  
 0 = Standard 100 KHz mode enabled (Default)  
 1 = Fast Mode Plus enabled (1MHz operation on PMBus)
- Bit 3: FAST\_MODE** – Fast Mode Enable  
 0 = Standard 100 KHz mode enabled (Default)  
 1 = Fast Mode enabled (400KHz operation on PMBus)
- Bit 2: BUS\_LO\_INT\_EDGE** – Clock Low Timeout Interrupt Edge Select  
 0 = Interrupt generated on rising edge of clock low timeout (Default)

1 = Interrupt generated on falling edge of clock low timeout

**Bit 1: ALERT\_EN** – Slave Alert Enable

0 = PMBus Alert is not driven by slave, pulled up high on PMBus (Default)

1 = PMBus Alert driven low by slave

**Bit 0: RESET** – PMBus Interface Synchronous Reset

0 = No reset of internal state machines (Default)

1 = Control state machines are reset to initial states

## A.9 GIO – General Purpose Input/Output Module

GIO Registers have the following attributes:

- Addresses placed on word boundaries
- Byte, Half-word and Word Writes are permitted
- All Registers can be read in any mode
- All Registers are writeable

### A.9.1 Fault IO Direction Register (FAULTDIR)

Address FFF7FA00

Bit Number	6	5	4	3	2	1	0
Bit Name	TMS_DIR	TDI_DIR	TDO_DIR	FLT3_DIR	FLT2_DIR	FLT1_DIR	FLT0_DIR
Access	R/W	R/W	R/W	R/W	R/W	R/W	R/W
Default	0	0	0	0	0	0	0

**Bit 6: TMS\_DIR** – TMS Pin Configuration

0 = TMS pin configured as an input pin in GPIO mode (Default)

1 = TMS pin configured as an output pin in GPIO mode

**Bit 5: TDI\_DIR** – TDI Pin Configuration

0 = TDI pin configured as an input pin in GPIO mode (Default)

1 = TDI pin configured as an output pin in GPIO mode

**Bit 4: TDO\_DIR** – TDO Pin Configuration

0 = TDO pin configured as an input pin in GPIO mode (Default)

1 = TDO pin configured as an output pin in GPIO mode

**Bit 3: FLT3\_DIR** – FAULT[3] Pin Configuration

0 = FAULT[3] pin configured as an input pin (Default)

1 = FAULT[3] pin configured as an output pin

**Bit 2: FLT2\_DIR** – FAULT[2] Pin Configuration

0 = FAULT[2] pin configured as an input pin (Default)

1 = FAULT[2] pin configured as an output pin

**Bit 1: FLT1\_DIR** – FAULT[1] Pin Configuration

0 = FAULT[1] pin configured as an input pin (Default)

1 = FAULT[1] pin configured as an output pin

**Bit 0: FLT0\_DIR** – FAULT[0] Pin Configuration

0 = FAULT[0] pin configured as an input pin (Default)

1 = FAULT[0] pin configured as an output pin

### A.9.2 Fault Input Register (FAULTIN)

Address FFF7FA04

Bit Number	6	5	4	3	2	1	0
Bit Name	TMS_IN	TDI_IN	TDO_IN	FLT3_IN	FLT2_IN	FLT1_IN	FLT0_IN
Access	R	R	R	R	R	R	R
Default	-	-	-	-	-	-	-

**Bit 6: TMS\_IN** – Input Value of TMS Pin

- 0 = TMS pin driven low in GPIO mode
- 1 = TMS pin driven high in GPIO mode

**Bit 5: TDI\_IN** – Input Value of TDI Pin

- 0 = TDI pin driven low in GPIO mode
- 1 = TDI pin driven high in GPIO mode

**Bit 4: TDO\_IN** – Input Value of TDO Pin

- 0 = TDO pin driven low in GPIO mode
- 1 = TDO pin driven high in GPIO mode

**Bit 3: FLT3\_IN** – Input Value of FAULT[3] Pin

- 0 = FAULT[3] pin driven low
- 1 = FAULT[3] pin driven high

**Bit 2: FLT2\_IN** – Input Value of FAULT[2] Pin

- 0 = FAULT[2] pin driven low
- 1 = FAULT[2] pin driven high

**Bit 1: FLT1\_IN** – Input Value of FAULT[1] Pin

- 0 = FAULT[1] pin driven low
- 1 = FAULT[1] pin driven high

**Bit 0: FLT0\_IN** – Input Value of FAULT[0] Pin

- 0 = FAULT[0] pin driven low
- 1 = FAULT[0] pin driven high

### A.9.3 Fault Output Register (FAULTOUT)

Address FFF7FA08

Bit Number	6	5	4	3
Bit Name	TMS_OUT	TDI_OUT	RESERVED	FLT3_OUT
Access	R/W	R/W	-	R/W
Default	0	0	0	0

Bit Number	2	1	0
Bit Name	FLT2_OUT	FLT1_OUT	FLT0_OUT
Access	R/W	R/W	R/W
Default	0	0	0

**Bit 6: TMS\_OUT** – TMS Pin Output Value

- 0 = TMS pin driven low when configured as output in GPIO mode (Default)
- 1 = TMS pin driven high when configured as output in GPIO mode

**Bit 5: TDI\_OUT** – TDI Pin Output Value

- 0 = TDI pin driven low when configured as output in GPIO mode (Default)
- 1 = TDI pin driven high when configured as output in GPIO mode

**Bit 4: RESERVED** – Unused Bit

**Bit 3: FLT3\_OUT** – FAULT[3] Pin Output Value

0 = FAULT[3] pin driven low when configured as output (Default)

1 = FAULT[3] pin driven high when configured as output

**Bit 2: FLT2\_OUT** – FAULT[2] Pin Output Value

0 = FAULT[2] pin driven low when configured as output (Default)

1 = FAULT[2] pin driven high when configured as output

**Bit 1: FLT1\_OUT** – FAULT[1] Pin Output Value

0 = FAULT[1] pin driven low when configured as output (Default)

1 = FAULT[1] pin driven high when configured as output

**Bit 0: FLT0\_OUT** – FAULT[0] Pin Output Value

0 = FAULT[0] pin driven low when configured as output (Default)

1 = FAULT[0] pin driven high when configured as output

#### **A.9.4 Fault Interrupt Enable Register (FAULTINTENA)**

Address FFF7FA14

Bit Number	6	5	4
Bit Name	TMS_INT_EN	TDI_INT_EN	TDO_INT_EN
Access	R/W	R/W	R/W
Default	0	0	0

Bit Number	3	2	1	0
Bit Name	FLT3_INT_EN	FLT2_INT_EN	FLT1_INT_EN	FLT0_INT_EN
Access	R/W	R/W	R/W	R/W
Default	0	0	0	0

**Bit 6: TMS\_INT\_EN** – TMS Interrupt Enable

0 = Interrupt disabled for TMS pin (Default)

1 = Interrupt enabled for TMS pin in GPIO mode

**Bit 5: TDI\_INT\_EN** – TDI Interrupt Enable

0 = Interrupt disabled for TDI pin (Default)

1 = Interrupt enabled for TDI pin in GPIO mode

**Bit 4: TDO\_INT\_EN** – TDO Interrupt Enable

0 = Interrupt disabled for TDO pin (Default)

1 = Interrupt enabled for TDO pin in GPIO mode

**Bit 3: FLT3\_INT\_EN** – FAULT[3] Interrupt Enable

0 = Interrupt disabled for FAULT[3] pin (Default)

1 = Interrupt enabled for FAULT[3] pin

**Bit 2: FLT2\_INT\_EN** – FAULT[2] Interrupt Enable

0 = Interrupt disabled for FAULT[2] pin (Default)

1 = Interrupt enabled for FAULT[2] pin

**Bit 1: FLT1\_INT\_EN** – FAULT[1] Interrupt Enable

0 = Interrupt disabled for FAULT[1] pin (Default)

1 = Interrupt enabled for FAULT[1] pin

**Bit 0: FLT0\_INT\_EN** – FAULT[0] Interrupt Enable

0 = Interrupt disabled for FAULT[0] pin (Default)

1 = Interrupt enabled for FAULT[0] pin

#### **A.9.5 Fault Interrupt Polarity Register (FAULTINTPOL)**

Address FFF7FA18

Bit Number	6	5	4
Bit Name	TMS_INT_POL	TDI_INT_POL	TDO_INT_POL
Access	R/W	R/W	R/W
Default	0	0	0

Bit Number	3	2	1	0
Bit Name	FLT3_INT_POL	FLT2_INT_POL	FLT1_INT_POL	FLT0_INT_POL
Access	R/W	R/W	R/W	R/W
Default	0	0	0	0

**Bit 6: TMS\_INT\_POL** – TMS Interrupt Polarity Select

0 = Interrupt generated on falling edge (Default)

1 = Interrupt generated on rising edge

**Bit 5: TDI\_INT\_POL** – TDI Interrupt Polarity Select

0 = Interrupt generated on falling edge (Default)

1 = Interrupt generated on rising edge

**Bit 4: TDO\_INT\_POL** – TDO Interrupt Polarity Select

0 = Interrupt generated on falling edge (Default)

1 = Interrupt generated on rising edge

**Bit 3: FLT3\_INT\_POL** – FAULT[3] Interrupt Polarity Select

0 = Interrupt generated on falling edge (Default)

1 = Interrupt generated on rising edge

**Bit 2: FLT2\_INT\_POL** – FAULT[2] Interrupt Polarity Select

0 = Interrupt generated on falling edge (Default)

1 = Interrupt generated on rising edge

**Bit 1: FLT1\_INT\_POL** – FAULT[1] Interrupt Polarity Select

0 = Interrupt generated on falling edge (Default)

1 = Interrupt generated on rising edge

**Bit 0: FLT0\_INT\_POL** – FAULT[0] Interrupt Polarity Select

0 = Interrupt generated on falling edge (Default)

1 = Interrupt generated on rising edge

### A.9.6 Fault Interrupt Pending Register (FAULTINTPEND)

Address FFF7FA1C

Bit Number	6	5	4
Bit Name	TMS_INT_PEND	TDI_INT_PEND	TDO_INT_PEND
Access	R/W	R/W	R/W
Default	0	0	0

Bit Number	3	2	1	0
Bit Name	FLT3_INT_PEND	FLT2_INT_PEND	FLT1_INT_PEND	FLT0_INT_PEND
Access	R/W	R/W	R/W	R/W
Default	0	0	0	0

**Bit 6: TMS\_INT\_PEND** – TMS has caused an interrupt. Writing a 1 to a bit will clear the interrupt flag  
 0 = No Interrupt detected (Default)  
 1 = Interrupt pending

**Bit 5: TDI\_INT\_PEND** – TDI has caused an interrupt. Writing a 1 to a bit will clear the interrupt flag  
 0 = No Interrupt detected (Default)  
 1 = Interrupt pending

**Bit 4: TDO\_INT\_PEND** – TDO has caused an interrupt. Writing a 1 to a bit will clear the interrupt flag  
 0 = No Interrupt detected (Default)  
 1 = Interrupt pending

**Bit 3: FLT3\_INT\_PEND** – FAULT[3] has caused an interrupt. Writing a 1 to a bit will clear the interrupt flag  
 0 = No Interrupt detected (Default)  
 1 = Interrupt pending

**Bit 2: FLT2\_INT\_PEND** – FAULT[2] has caused an interrupt. Writing a 1 to a bit will clear the interrupt flag  
 0 = No Interrupt detected (Default)  
 1 = Interrupt pending

**Bit 1: FLT1\_INT\_PEND** – FAULT[1] has caused an interrupt. Writing a 1 to a bit will clear the interrupt flag  
 0 = No Interrupt detected (Default)  
 1 = Interrupt pending

**Bit 0: FLT0\_INT\_PEND** – FAULT[0] has caused an interrupt. Writing a 1 to a bit will clear the interrupt flag  
 0 = No Interrupt detected (Default)  
 1 = Interrupt pending

### A.9.7 External Interrupt Direction Register (EXTINTDIR)

Address FFF7FA20

Bit Number	0
Bit Name	EXT_INT_DIR
Access	R/W
Default	0

**Bit 0: EXT\_INT\_DIR** – EXT-INT Pin Configuration  
 0 = EXT-INT pin configured as an input pin (Default)  
 1 = EXT-INT pin configured as an output pin

### A.9.8 External Interrupt Input Register (EXTINTIN)

Address FFF7FA24

Bit Number	0
Bit Name	EXT_INT_IN
Access	R
Default	-

**Bit 0: EXT\_INT\_IN** – Input Value of EXT-INT Pin  
 0 = EXT-INT pin driven low in GPIO mode  
 1 = EXT-INT pin driven high in GPIO mode

### A.9.9 External Interrupt Output Register (EXTINTOUT)

Address FFF7FA28

Bit Number	0
Bit Name	EXT_INT_OUT
Access	R/W
Default	0

**Bit 0: EXT\_INT\_OUT** – EXT-INT Pin Output Value  
 0 = EXT-INT pin driven low (Default)  
 1 = EXT-INT pin driven high

### A.9.10 External Interrupt Enable Register (EXTINTENA)

Address FFF7FA34

Bit Number	0
Bit Name	EXT_INT_EN
Access	R/W
Default	0

**Bit 0: EXT\_INT\_EN** – EXT-INT Interrupt Enable  
 0 = Interrupt disabled for EXT-INT pin (Default)  
 1 = Interrupt enabled for EXT-INT pin

### A.9.11 External Interrupt Polarity Register (EXTINTPOL)

Address FFF7FA38



<b>Bit Number</b>	<b>0</b>
<b>Bit Name</b>	EXT_INT_POL
<b>Access</b>	R/W
<b>Default</b>	0

**Bit 0: EXT\_INT\_POL** – EXT-INT Interrupt Polarity Select  
 0 = Interrupt generated on falling edge (Default)  
 1 = Interrupt generated on rising edge

### **A.9.12 External Interrupt Pending Register (EXTINTPEND)**

**Address FFF7FA3C**

<b>Bit Number</b>	<b>0</b>
<b>Bit Name</b>	EXT_INT_PEND
<b>Access</b>	R/W
<b>Default</b>	0

**Bit 0: EXT\_INT\_PEND** – EXT-INT has caused an interrupt. Writing a 1 to a bit will clear the interrupt flag.

## A.10 Timer Module

Timer Registers have the following attributes:

- 32-bit wide
- Addresses placed on word boundaries
- Byte, Half-Word and word writes permitted
- All Registers can be read in any mode
- All Registers, except for the Timer Powerdown Control Register, are writeable in any mode. The Timer Powerdown Control Register is writeable only in privilege mode.

### A.10.1 24-bit Counter Data Register (T24CNTDAT)

Address FFF7FD00

<b>Bit Number</b>	<b>23:0</b>
<b>Bit Name</b>	CNT_DAT
<b>Access</b>	R
<b>Default</b>	-

**Bits 23-0: CNT\_DAT:** – Contains the 24-bit counter value

### A.10.2 24-bit Counter Control Register (T24CNTCTRL)

Address FFF7FD04

Bit Number	15:8	7:3	2	1	0
<b>Bit Name</b>	PRESCALE	RESERVED	EXT_CLK_SEL	OV_INT_ENA	OV_FLAG
<b>Access</b>	R/W	-	R/W	R/W	R
<b>Default</b>	0000_0000	00000	0	0	0

**Bits 15-8: PRESCALE** – Defines the prescaler value used to select the 24-bit counter resolution. The minimum divider ratio is 4, prescaler value less than 3 defaults to 3.

$$\text{Counter Resolution} = (\text{Prescaler Value} + 1) * 1/\text{ICLK}$$

**Bits 7-3: RESERVED** – Unused bits

**Bit 2: EXT\_CLK\_SEL** – External Clock Select

0 = Selects ICLK as clock for 24-bit counter (Default)

1 = Selects External Clock on FAULT-0 as clock for 24-bit counter

**Bit 1: OV\_INT\_ENA** – Counter Overflow Interrupt Enable

0 = Disables 24-bit Counter Overflow Interrupt (Default)

1 = Enables 24-bit Counter Overflow Interrupt

**Bit 0: OV\_FLAG** – Indicates a counter overflow. Overflow event is cleared by writing a '1' to this bit. If a clear and an overflow event occur at the same time, the flag will remain high (set has priority versus clear).

0 = No counter overflow since last clear

1 = Counter overflow since last clear

**A.10.3 24-bit Capture Channel Data Register (T24CAPDAT)**
**Address FFF7FD08**

<b>Bit Number</b>	<b>23:0</b>
<b>Bit Name</b>	CAP_DAT
<b>Access</b>	R
<b>Default</b>	-

**Bits 23-0: CAP\_DAT**– Contains the 24-bit input capture value

**A.10.4 24-bit Capture Channel Control Register (T24CAPCTRL)**
**Address FFF7FD14**

<b>Bit Number</b>	<b>5:4</b>	<b>3:2</b>	<b>1</b>	<b>0</b>
<b>Bit Name</b>	CAP_SEL	EDGE	CAP_INT_ENA	CAP_INT_FLAG
<b>Access</b>	R/W	R/W	R/W	R/W
<b>Default</b>	00	00	0	0

**Bits 5-4: CAP\_SEL** – Capture Pin Select

00 = TCAP pin (Default)

01 = SCI\_RX[0] pin

10 = SCI\_RX[1] pin

11 = SYNC pin

**Bits 3-2: EDGE** – Input Capture Edge Select

00 = No Capture (Default)

01 = Rising Edge

10 = Falling Edge

11 = Both Edges

**Bit 1: CAP\_INT\_ENA** – Input Capture Interrupt Enable

0 = Disables 24-bit input capture interrupt (Default)

1 = Enables 24-bit input capture interrupt

**Bit 0: CAP\_INT\_FLAG** – Flag which indicates a valid input capture event. This bit is cleared by writing a ‘1’ to it or by reading the corresponding Capture Channel Data Register. If a clear and a valid capture event occur at the same time, the flag will remain high (set has priority versus clear).

0 = No valid capture event since last clear

1 = Valid capture event since last clear

**A.10.5 24-bit Capture I/O Control and Data Register (T24CAPIO)**
**Address FFF7FD20**

<b>Bit Number</b>	<b>2</b>	<b>1</b>	<b>0</b>
<b>Bit Name</b>	TCAP_IN	TCAP_OUT	TCAP_DIR
<b>Access</b>	R	R/W	R/W
<b>Default</b>	-	0	0

**Bit 2: TCAP\_IN** – Input data for pin TCAP pin, when connected to chip I/O

0 = Logic level low detected on TCAP pin

1 = Logic level high detected on TCAP pin

**Bit 1: TCAP\_OUT** – Output data for pin TCAP pin, when connected to chip I/O

0 = Logic level low driven on TCAP pin in output mode (Default)

1 = Logic level high driven on TCAP pin in output mode

**Bit 0: TCAP\_DIR** – Controls data direction for pin TCAP, when connected to chip I/O  
 0 = TCAP pin configured as input (Default)  
 1 = TCAP pin configured as output

### **A.10.6 24-bit Output Compare Channel 0 Data Register (T24CMPDAT0)**

**Address FFF7FD24**

<b>Bit Number</b>	<b>23:0</b>
<b>Bit Name</b>	CMP_DAT
<b>Access</b>	R/W
<b>Default</b>	0000_0000_0000_0000_0000_0000

**Bits 23-0: CMP\_DAT**– Contains the 24-bit output comparison value

### **A.10.7 24-bit Output Compare Channel 1 Data Register (T24CMPDAT1)**

**Address FFF7FD28**

<b>Bit Number</b>	<b>23:0</b>
<b>Bit Name</b>	CMP_DAT
<b>Access</b>	R/W
<b>Default</b>	0000_0000_0000_0000_0000_0000

**Bits 23-0: CMP\_DAT**– Contains the 24-bit output comparison value

### **A.10.8 24-bit Output Compare Channel 0 Control Register (T24CMPCTRL0)**

**Address FFF7FD2C**

<b>Bit Number</b>	<b>1</b>	<b>0</b>
<b>Bit Name</b>	CMP_INT_ENA	CMP_INT_FLAG
<b>Access</b>	R/W	R/W
<b>Default</b>	0	0

**Bit 1: CMP\_INT\_ENA**– Output Compare Channel Interrupt  
 0 = Disables Output Compare Channel Interrupt (Default)  
 1 = Enables Output Compare Channel Interrupt

**Bit 0: CMP\_INT\_FLAG** – Indicates a valid output compare event. Bit can be cleared by writing a ‘1’ to the bit or by rewriting the 24-bit Output Compare Channel Data Register. If a clear and compare event occur at the same time, the flag will remain high (set has priority versus clear).

0 = No compare event since last clear  
 1 = Compare event since last clear

#### **1.1 24-bit Output Compare Channel 1 Control Register (T24CMPCTRL1)**

**Address FFF7FD30**

<b>Bit Number</b>	<b>1</b>	<b>0</b>
<b>Bit Name</b>	CMP_INT_ENA	CMP_INT_FLAG
<b>Access</b>	R/W	R/W
<b>Default</b>	0	0

**Bit 1: CMP\_INT\_ENA**– Output Compare Channel Interrupt  
 0 = Disables Output Compare Channel Interrupt (Default)

1 = Enables Output Compare Channel Interrupt

**Bit 0: CMP\_INT\_FLAG** – Indicates a valid output compare event. Bit can be cleared by writing a ‘1’ to the bit or by rewriting the 24-bit Output Compare Channel Data Register. If a clear and compare event occur at the same time, the flag will remain high (set has priority versus clear).

0 = No compare event since last clear

1 = Compare event since last clear

## 1.2 PWMx Counter Data Register (T16PWMxCNTDAT)

**Address FFF7FD34 – 16-bit PWM0 Counter Data Register**

**Address FFF7FD58 – 16-bit PWM1 Counter Data Register**

**Address FFF7FD6C – 16-bit PWM2 Counter Data Register**

**Address FFF7FD80 – 16-bit PWM3 Counter Data Register**

Bit Number	15:0
Bit Name	CNT_DAT
Access	R
Default	-

**Bits 15-0: CNT\_DAT** – Contains the 16-bit counter value. Read-only.

### 1.3 PWMx Counter Control Register (T16PWMxCNTCTRL)

Address FFF7FD38 – 16-bit PWM0 Counter Control Register

Address FFF7FD5C – 16-bit PWM1 Counter Control Register

Address FFF7FD70 – 16-bit PWM2 Counter Control Register

Address FFF7FD84 – 16-bit PWM3 Counter Control Register

Bit Number	15:8	7	6:5	4
Bit Name	PRESCALE	RESERVED	SYNC_SEL	SYNC_EN
Access	R/W	-	R/W	R/W
Default	0000_0000	0	00	0

Bit Number	3	2	1	0
Bit Name	SW_RESET	CMP_RESET_ENA	OV_INT_ENA	OV_INT_FLAG
Access	R/W	R/W	R/W	R/W
Default	0	0	0	0

**Bit 15-8: PRESCALE** – Defines the prescaler value to select the PWM counter resolution.

$$\text{Counter Resolution} = (\text{Prescaler} + 1) * 1/\text{ICLK}$$

**Bit 7: RESERVED** – Unused bit

**Bits 6:5: SYNC\_SEL** – Configures master PWM counter

0 = PWM0 Counter (Default)

1 = PWM1 Counter

2 = PWM2 Counter

3 = PWM3 Counter

**Bit 4: SYNC\_EN** – PWM counter starts when master PWM counter is enabled

0 = PWM counter independent of other PWM counters (Default)

1 = PWM counter controlled by Master PWM counter

**Bit 3: SW\_RESET** – PWM counter reset by software. This bit is cleared after reset and has to be set to run the PWM counter.

0 = PWM counter reset and counter stop (Default)

1 = PWM counter is running

**Bit 2: CMP\_RESET\_ENA** – Enables PWM counter reset by compare action of T16CMPxDR.

0 = Disable PWM counter reset by compare action (Default)

1 = Enable PWM counter reset by compare action

**Bit 1: OV\_INT\_ENA** – PWM Counter Overflow Interrupt Enable

0 = Disable PWM counter overflow interrupt (Default)

1 = Enable PWM counter overflow interrupt

**Bit 0: OV\_INT\_FLAG** – Flag which indicates a PWM counter overflow. This bit is cleared by writing ‘1’ to it. If a clear and an overflow event occur at the same time, the flag will remain high (set has priority versus clear).

0 = No PWM counter overflow since last clear

1 = PWM counter overflow since last clear

### 1.4 PWMx 16-bit Compare Channel 0-1 Data Register (T16PWMxCMPyDAT)

Address FFF7FD3C – 16-bit PWM0 Compare Channel 0 Data Register

Address FFF7FD40 – 16-bit PWM0 Compare Channel 1 Data Register

Address FFF7FD60 – 16-bit PWM1 Compare Channel 0 Data Register

Address FFF7FD64 – 16-bit PWM1 Compare Channel 1 Data Register

Address FFF7FD74 – 16-bit PWM2 Compare Channel 0 Data Register

Address FFF7FD78 – 16-bit PWM2 Compare Channel 1 Data Register

**Address FFF7FD88 – 16-bit PWM3 Compare Channel 0 Data Register**

**Address FFF7FD8C – 16-bit PWM3 Compare Channel 1 Data Register**

<b>Bit Number</b>	<b>15:0</b>
<b>Bit Name</b>	CMP_DAT
<b>Access</b>	R/W
<b>Default</b>	0000_0000_0000_0000

**Bits 15-0: CMP\_DAT** – Contains the 16-bit compare value. When in PWM mode, the value in the T16PWMxCMPyDAT is loaded after a match with the PWMx Counter Data Register. When in OC mode, it has to be written by the CPU. The mode is controlled by the bit SHADOW in the PWMx/Dual Compare Control Register. If both Registers T16PWMxCMP0DAT and T16PWMxCMP1DAT contain the same value, the interrupt and pin behavior is controlled by output compare channel 0 (T16PWMxCMP0DAT has priority over T16PWMxCMP1DAT).

### 1.5 PWM Compare Control Register (T16PWMxCMPCTRL)

Address FFF7FD44 – 16-bit PWM0 Compare Control Register

Address FFF7FD68 – 16-bit PWM1 Compare Control Register

Bit Number	12	11	10	9	8
Bit Name	SHADOW	PWM_IN	PWM_OUT	PWM_OUT_ENA	PWM_OUT_DRV
Access	R/W	R	R/W	R/W	R/W
Default	0	-	0	0	0

Bit Number	7:6	5:4	3
Bit Name	PWM_OUT_ACTION1	PWM_OUT_ACTION0	CMP1_INT_ENA
Access	R/W	R/W	R/W
Default	00	00	0

Bit Number	2	1	0
Bit Name	CMP1_INT_FLAG	CMP0_INT_ENA	CMP0_INT_FLAG
Access	R/W	R/W	R/W
Default	0	0	0

**Bit 12: SHADOW** – Controls the update of the 16-bit output compare Registers.

0 = PWM output compare Registers immediately written (Default)

1 = PWM output compare Registers updated through the buffers

T16PWMxCMPyDAT after a match occurs in the corresponding Register T16PWMxCMPyDAT.

**Bit 11: PWM\_IN** – Input value of PWM pin when configured in PWM mode

0 = Logic level low detected on PWM pin

1 = Logic level high detected on PWM pin

**Bit 10: PWM\_OUT** – Data to be written into the output latch when PWM\_OUT\_DRV is high.

0 = Output latch is cleared when PWM\_OUT\_DRV=1 (Default)

1 = Output latch is set when PWM\_OUT\_DRV=1

**Bit 9: PWM\_OUT\_ENA** – FAN-PWM pin configuration

0 = FAN-PWM configured as an input pin (Default)

1 = FAN-PWM configured as an output pin

**Bit 8: PWM\_OUT\_DRV** – Causes the value of the bit PWM\_OUT to be written into the output latch. So it is possible to preload the output latch or to use the pin as GPIO. The compare action has priority before the preload function. This bit is always read as '0'.

0 = Output latch not affected by the value of PWM\_OUT (Default)

1 = Value of OUT written into the output latch

**Bits 7-6: PWM\_OUT\_ACTION1** – These 2 bits select the output action when a compare equal is detected on T16CMP1DAT

00 = No action (Default)

01 = Set pin

10 = Clear pin

11 = Toggle pin

**Bits 5-4: PWM\_OUT\_ACTION0** – Selects the output action when a compare equal is detected on T16CMP0DAT.

00 = No action (Default)

01 = Set pin

10 = Clear pin

11 = Toggle pin

**Bit 3: CMP1\_INT\_ENA** – Compare 1 Interrupt Enable

0 = Disables Compare 1 Interrupt (Default)



1 = Enables Compare 1 Interrupt

**Bit 2: CMP1\_INT\_FLAG** – Flag which indicates a valid output compare 1 event. This bit is cleared by writing ‘1’ to this bit or by rewriting T16PWMxCMP1DAT. If a clear and a compare event occurs at the same time, the flag will remain high (set has priority versus write clear).

0 = No compare event since last clear

1 = Compare event since last clear

**Bit 1: CMP0\_INT\_ENA** – Compare 0 Interrupt Enable

0 = Disables Compare 0 Interrupt (Default)

1 = Enables Compare 0 Interrupt

**Bit 0: CMP0\_INT\_FLAG** – Flag which indicates a valid output compare 1 event. This bit is cleared by writing ‘1’ to this bit or by rewriting T16PWMxCMP0DAT. If a clear and a compare event occurs at the same time, the flag will remain high (set has priority versus write clear).

0 = No compare event since last clear

1 = Compare event since last clear

## 1.6 PWMx Compare Control Register (T16PWMxCMPCTRL)

Address FFF7FD7C – 16-bit PWM2 Compare Control Register

Address FFF7FD90 – 16-bit PWM3 Compare Control Register

Bit Number	12	11:4	3
Bit Name	SHADOW	RESERVED	CMP1_INT_ENA
Access	R/W	R/W	R/W
Default	0	0000_0000	0

Bit Number	2	1	0
Bit Name	CMP1_INT_FLAG	CMP0_INT_ENA	CMP0_INT_FLAG
Access	R/W	R/W	R/W
Default	0	0	0

**Bit 12: SHADOW** – Controls the update of the 16-bit output compare Registers.

0 = PWM output compare Registers immediately written (Default)

1 = PWM output compare Registers updated through the buffers

T16PWMxCMPyDAT after a match occurs in the corresponding Register T16PWMxCMPyDAT.

**Bits 11-4: RESERVED** – Unused bits

**Bit 3: CMP1\_INT\_ENA**– Compare 1 Interrupt Enable

0 = Disables Compare 1 Interrupt (Default)

1 = Enables Compare 1 Interrupt

**Bit 2: CMP1\_INT\_FLAG** – Flag which indicates a valid output compare 1 event. This bit is cleared by writing ‘1’ to this bit or by rewriting T16PWMxCMP1DAT. If a clear and a compare event occurs at the same time, the flag will remain high (set has priority versus write clear).

0 = No compare event since last clear

1 = Compare event since last clear

**Bit 1: CMP0\_INT\_ENA** – Compare 0 Interrupt Enable

0 = Disables Compare 0 Interrupt (Default)

1 = Enables Compare 0 Interrupt

**Bit 0: CMP0\_INT\_FLAG** – Flag which indicates a valid output compare 1 event. This bit is cleared by writing ‘1’ to this bit or by rewriting T16PWMxCMP0DAT. If a clear and a compare event occurs at the same time, the flag will remain high (set has priority versus write clear).

0 = No compare event since last clear

1 = Compare event since last clear

## 1.7 Watchdog Status (WDST)

Address FFF7FD94

Bit Number	3	2	1	0
Bit Name	WAKE_EV_RAW	WD_EV_RAW	WAKE_EV_INT	WD_EV_INT
Access	R	R	R	R
Default	-	-	-	-

**Bit 3: WAKE\_EV\_INT** – Watchdog Wake Event Raw Status

0 = Watchdog Timer has not reached ½ of terminal count

1 = Watchdog Timer has reached ½ of terminal count

**Bit 2: WD\_EV\_RAW** – Watchdog Event Raw Status

0 = Watchdog Timer has not reached terminal count

1 = Watchdog Timer has reached terminal count

**Bit 1: WAKE\_EV\_INT** – Watchdog Wake Event Interrupt Status, cleared on read of Watchdog Status Register

0 = Watchdog Timer has not reached ½ of terminal count

1 = Watchdog Timer has reached ½ of terminal count

**Bit 0: WD\_EV\_INT** – Watchdog Event Interrupt Status, cleared on read of Watchdog Status Register

0 = Watchdog Timer has not reached terminal count

1 = Watchdog Timer has reached terminal count

## 1.8 Watchdog Control (WDCTRL)

Address FFF7FD98

Bit Number	14:8	7	6	5	4
Bit Name	PERIOD	RESERVED	PROTECT	CPU_RESET_EN	WDRST_INT_EN
Access	R/W	-	R/W	R/W	R/W
Default	111_1111	0	1	0	0

Bit Number	3	2	1	0
Bit Name	WKEV_INT_EN	WKEV_EN	WDRST_EN	CNT_RESET
Access	R/W	R/W	R/W	R/W
Default	0	0	0	1

**Bits 14-8: PERIOD** - Configures the time for the watchdog reset.

H'7F ~ 1.3s (minimum) (Default)

H'00 ~ 10ms (maximum)

**Bit 7: RESERVED** – Unused bits

**Bit 6: PROTECT** – Watchdog Protect Bit, Active Low

0 = Watchdog enable bits are protected, only can be cleared by POR. CPU\_RESET\_ENA (Bit 5),

WDRST\_ENA (Bit 2) and WKEV\_ENA (Bit 1) are automatically set high when PROTECT is written low.

1 = Watchdog enable bits can be set by processor (Default)

**Bit 5: CPU\_RESET\_EN** – Enables Watchdog Reset Event to reset the CPU

0 = Watchdog Reset does not reset CPU (Default)

1 = Watchdog Reset does resets CPU

**Bit 4: WDRST\_INT\_EN** – Watchdog Reset Event Interrupt Enable

0 = Disables generation of Watchdog Reset Interrupt

1 = Enables generation of Watchdog Reset Interrupt (Default)

**Bit 3: WKEN\_INT\_EN** – Watchdog Wake Event Interrupt Enable

0 = Disables generation of Watchdog Wake Event Interrupt

1 = Enables generation of Watchdog Wake Event Interrupt (Default)

**Bit 2: WKEV\_EN** – Watchdog Wake Event Comparator Enable

- 0 = Disables Watchdog Wake Event Comparator
- 1 = Enables Watchdog Wake Event Comparator (Default)

**Bit 1: WDRST\_EN** – Watchdog Reset Event Comparator Enable

- 0 = Disables Watchdog Reset Event Comparator
- 1 = Enables Watchdog Reset Event Comparator (Default)

**Bit 0: CNT\_RESET** – This bit resets the watchdog counters. This bit self clears and if the enables are set, the counters restart counting.

- 0 = Watchdog counters enabled (Default)
- 1 = Watchdog counters reset

## 2 Memory Controller - MMC

All MMC control Registers have the following attributes:

- 16-bit wide
- Addresses placed on word boundaries
- 16-bit data is placed on the least significant data bus D[15:0]
- Only half-word writes are permitted
- Registers are readable in any mode, but writeable only in privilege mode

### 2.1 Static Memory Control Register (SMCTRL)

Address **FFFFD00**

Bit Number	13:12	11:9	7:4	3	1:0
Bit Name	LEAD	TRAIL	ACTIVE	ENDIAN	WIDTH
Access	R/W	R/W	R/W	R	R/W
Default	00	000	0000	-	00

**Bits 13-12: LEAD** – Address setup time cycles (write operations)

- 00 = No setup time required (Default)
- 01 = Write strobe is delayed one cycle
- 10 = Write strobe is delayed two cycles
- 11 = Write strobe is delayed three cycles

**Bits 11-9: TRAIL** – Number of Trailing wait states. Determine the trailing wait states after read and write operations to the memory associated with the chip select corresponding to the wait states.

**Bit s 7-4: ACTIVE** – Active Wait states (both read/write operations)

- 0000 = 0 Wait states (Default)
- 0001 = 1 Wait states
  - 0010 = 2 Wait states
  - 0011 = 3 Wait states
- 0100 = 4 Wait states
- 0101 = 5 Wait states
  - 0110 = 6 Wait states
  - 0111 = 7 Wait states
  - 1000 = 8 Wait states
- 1001 = 9 Wait states
  - 1010 = 10 Wait states
  - 1011 = 11 Wait states
- 1100 = 12 Wait states

1101 = 13 Wait states

1110 = 14 Wait states

1111 = 15 Wait states

**Bit 3: ENDIAN** – Endian Mode Identification

0 = CPU configured in big endian mode

1 = CPU configured in little endian mode

**Bits 1-0: WIDTH** – Data Width for Memories

00 = 8 bits (Default)

01 = 16 bits

10 = 32 bits

11 = Reserved

## 2.2 Write Control Register (WCTRL)

Address FFFFFFFD2C

Bit Number	1	0
Bit Name	TRAIL_OVR	WBUF_ENA
Access	R/W	R/W
Default	0	0

**Bit 1: TRAIL\_OVR** – Write trailing wait state override.

0 = At least one trailing wait state (Default)

1 = TRAIL sets trailing wait states

**Bit 0: WBUF\_ENA** – Write buffer enable. When this bit is 1, the memory controller latches the data and control signals in the first cycle for write operations to the memories and peripherals on the expansion bus and lets the CPU perform other operations. However, the CPU starts a wait state if there is another request before the memory controller finishes.

0 = Write buffer disabled (Disabled)

1 = Write buffer enabled

## 2.3 Peripheral Control Register (PCTRL)

Address FFFFFFFD30

Bit Number	0
Bit Name	PBUF_ENA
Access	R/W
Default	0

**Bit 0: PBUF\_ENA** – Write buffer enable. When this bit is set to 1, the memory controller latches the data and control signals in the first cycle for write operations to the memories and peripherals on the expansion bus and lets the CPU perform other operations. However, the CPU starts a wait state if there is another request before the memory controller finishes.

0 = Write buffer disabled (Default)

1 = Write buffer enabled

## 2.4 Peripheral Location Register (PLOC)

Address FFFFD34

<b>Bit Number</b>	15:0
<b>Bit Name</b>	LOC
<b>Access</b>	R/W
<b>Default</b>	0000_0000_0000_0000

**Bits 15-0: LOC** – These 16 bits represent the peripheral location bits, which correspond to each of the 16 peripheral selects.

0 = Peripheral is internal (Default)

1 = Peripheral is external

## 2.5 Peripheral Protection Register (PPROT)

Address FFFFD38

<b>Bit Number</b>	15:0
<b>Bit Name</b>	PROT
<b>Access</b>	R/W
<b>Default</b>	0000_0000_0000_0000

**Bits 15-0: PROT** – These 16 bits represent the peripheral protection bits, which correspond to each of the 16 peripheral selects.

0 = Peripheral is accessible in all modes (Default)

1 = Peripheral is accessible in privilege mode only

### 3 DEC – Address Manager

The DEC generates the memory selects and SAR peripheral select signals by decoding the address and control signals from the ARM processor. In addition, the DEC provides the control signals for the Program and Data Flash.

The assigned memory selects for Cyclone are as follows:

- Memory Select 0 => Boot ROM (1Kx32)
- Memory Select 1 => Program Flash (8Kx32)
- Memory Select 2 => Data Flash (512x32)
- Memory Select 3 => Data RAM (1Kx32)
- Memory Select 4 => Shadow DPWM (1Kx32)
- Memory Select 5 => Loop Mux (1Kx32)
- Memory Select 6 => Fault Mux (1Kx32)
- Memory Select 7 => ADC12 Control (1Kx32)
- Memory Select 8 => DPWM3 (1Kx32)
- Memory Select 9 => Filter 2 (1Kx32)
- Memory Select 10 => DPWM 2 (1Kx32)
- Memory Select 11 => Front End Control 2 (1Kx32)
- Memory Select 12 => Filter 1 (1Kx32)
- Memory Select 13 => DPWM 1 (1Kx32)
- Memory Select 14 => Front End Control 1 (1Kx32)
- Memory Select 15 => Filter 0 (1Kx32)
- Memory Select 16 => DPWM 0 (1Kx32)
- Memory Select 17 => Front End Control 0 (1Kx32)

#### 3.1 Memory Fine Base Address High Register 0 (MFBAHR0)

Address FFFFFFFE00

Bit Number	15:0
Bit Name	ADDRESS[31:16]
Access	R/W
Default	0000_0000_0000_0000

**Bits 15-0: ADDRESS[31:16]** – 16 Most Significant Bits of the Base Address. The Base Address sets the 22 most significant bits of the memory address.

#### 3.2 Memory Fine Base Address Low Register 0 (MFBALR0)

Address FFFFFFFE04

Bit Number	15:10	8	7:4	1	0
Bit Name	ADDRESS[15:10]	MS	BLOCK_SIZE	RONLY	PRIV
Access	R/W	R/W	R/W	R/W	R/W
Default	000000	0	0000	0	0

**Bits 15-10: ADDRESS[15:10]** – 6 Least Significant Bits of the Base Address. The Base Address sets the 22 most significant bits of the memory address.

**Bit 8: MS** – Memory Map Select

0 = Memory Map configuration not updated (Default)

1 = Enables the fine and coarse memory selects and activates the memory map

**Bits 7-4: BLOCK\_SIZE** – Configures the size of the memory

0000 = Memory select is disabled (Default)

0001 = 1K Bytes  
 0010 = 2K Bytes  
 0011 = 4K Bytes  
 0100 = 8K Bytes  
 0101 = 16K Bytes  
 0110 = 32K Bytes  
 0111 = 64K Bytes  
 1000 = 128K Bytes  
 1001 = 256K Bytes  
 1010 = 512K Bytes  
 1011 = 1M Bytes  
 1100 = 2M Bytes  
 1101 = 4M Bytes  
 1110 = 8M Bytes  
 1111 = 16M Bytes

**Bit 1: RONLY** – Read-only protection. This bit sets read-only protection for the memory selected by the memory select. An illegal access exception is generated when a write is attempted to the memory.

0 = Read/write access to memory (Default)

1 = Read accesses to memory only

**Bit 0: PRIV** – Privilege mode protection. This bit sets privilege mode protection for the memory Registration selected by the memory select. An illegal access exception is generated on any access to memory protected by privilege mode.

0 = User/privilege mode accesses to memory (Default)

1 = Privilege mode accesses to memory only

### 3.3 Memory Fine Base Address High Register 1-3 (MFBAHRx)

**Address FFFFFFFE08 – Memory Fine Base Address High Register 1**

**Address FFFFFFFE10 – Memory Fine Base Address High Register 2**

**Address FFFFFFFE18 – Memory Fine Base Address High Register 3**

<b>Bit Number</b>	<b>15:0</b>
<b>Bit Name</b>	ADDRESS[31:16]
<b>Access</b>	R/W
<b>Default</b>	0000_0000_0000_0000

**Bits 15-0: ADDRESS[31:16]** – 16 Most Significant Bits of the Base Address. The Base Address sets the 22 most significant bits of the memory address.

### 3.4 Memory Fine Base Address Low Register 1-3 (MFBALRx)

**Address FFFFFFFE0C – Memory Fine Base Address Low Register 1**

**Address FFFFFFFE14 – Memory Fine Base Address Low Register 2**

**Address FFFFFFFE1C – Memory Fine Base Address Low Register 3**

Bit Number	15:10	9	7:4	1	0
<b>Bit Name</b>	ADDRESS[15:10]	AW	BLOCK_SIZE	RONLY	PRIV
<b>Access</b>	R/W	R/W	R/W	R/W	R/W
<b>Default</b>	000000	0	0000	0	0

**Bits 15-10: ADDRESS[15:10]** – 6 Least Significant Bits of the Base Address. The Base Address sets the 22 most significant bits of the memory address.

**Bit 9: AW** – Auto-wait-on-write. When this bit is set, any write operation on this memory select takes two system cycles.

0 = Write operation is not supplemented with an additional cycle (Default)

1 = Write operation takes an additional cycle

**Bits 7-4: BLOCK\_SIZE** – Configures the size of the memory

0000 = Memory select is disabled (Default)

0001 = 1K Bytes

0010 = 2K Bytes

0011 = 4K Bytes

0100 = 8K Bytes

0101 = 16K Bytes

0110 = 32K Bytes

0111 = 64K Bytes

1000 = 128K Bytes

1001 = 256K Bytes

1010 = 512K Bytes

1011 = 1M Bytes

1100 = 2M Bytes

1101 = 4M Bytes

1110 = 8M Bytes

1111 = 16M Bytes

**Bit 1: RONLY** – Read-only protection. This bit sets read-only protection for the memory selected by the memory select. An illegal access exception is generated when a write is attempted to the memory.

0 = Read/write access to memory (Default)

1 = Read accesses to memory only

**Bit 0: PRIV** – Privilege mode protection. This bit sets privilege mode protection for the memory Registration selected by the memory select. An illegal access exception is generated on any access to memory protected by privilege mode.

0 = User/privilege mode accesses to memory (Default)

1 = Privilege mode accesses to memory only

### 3.5 Memory Fine Base Address High Register 4 (MFBAHR4)

Address FFFFE20 – Memory Fine Base Address High Register 4

Bit Number	15:0
Bit Name	ADDRESS[31:16]
Access	R/W
Default	0000_0000_0000_0010

**Bits 15-0: ADDRESS[31:16]** – 16 Most Significant Bits of the Base Address. The Base Address sets the 22 most significant bits of the memory address.

### 3.6 Memory Fine Base Address Low Register 4-17 (MFBALRx)

Address FFFFE24 – Memory Fine Base Address Low Register 4

Address FFFFE2C – Memory Fine Base Address Low Register 5

Address FFFFE34 – Memory Fine Base Address Low Register 6

Address FFFFE3C – Memory Fine Base Address Low Register 7

Address FFFFE44 – Memory Fine Base Address Low Register 8

Address FFFFE4C – Memory Fine Base Address Low Register 9

Address FFFFE54 – Memory Fine Base Address Low Register 10

Address FFFFE5C – Memory Fine Base Address Low Register 11

Address FFFFE64 – Memory Fine Base Address Low Register 12

Address FFFFE6C – Memory Fine Base Address Low Register 13

Address FFFFE74 – Memory Fine Base Address Low Register 14

Address FFFFE7C – Memory Fine Base Address Low Register 15

Address FFFFE84 – Memory Fine Base Address Low Register 16



Bit Number	15:10	9	8:2	1	0
Bit Name	ADDRESS[15:10]	AW	RESERVED	RONLY	PRIV
Access	R/W	R/W	-	R/W	R/W
Default	000000	0	0_0000_00	0	0

**Bits 15-10: ADDRESS[15:10]** – 6 Least Significant Bits of the Base Address. The Base Address sets the 22 most significant bits of the memory address.

**Bit 9: AW** – Auto-wait-on-write. When this bit is set, any write operation on this memory select takes two system cycles.

0 = Write operation is not supplemented with an additional cycle (Default)

1 = Write operation takes an additional cycle

**Bits 8-2: RESERVED** – Unused bits

**Bit 1: RONLY** – Read-only protection. This bit sets read-only protection for the memory selected by the memory select. An illegal access exception is generated when a write is attempted to the memory.

0 = Read/write access to memory (Default)

1 = Read accesses to memory only

**Bit 0: PRIV** – Privilege mode protection. This bit sets privilege mode protection for the memory Registration selected by the memory select. An illegal access exception is generated on any access to memory protected by privilege mode.

0 = User/privilege mode accesses to memory (Default)

1 = Privilege mode accesses to memory only

### 3.7 Memory Fine Base Address High Register 5 (MFBAHR5)

Address FFFFE28 – Memory Fine Base Address High Register 5

Bit Number	15:0
Bit Name	ADDRESS[31:16]
Access	R/W
Default	0000_0000_0000_0011

**Bits 15-0: ADDRESS[31:16]** – 16 Most Significant Bits of the Base Address. The Base Address sets the 22 most significant bits of the memory address.

### 3.8 Memory Fine Base Address High Register 6 (MFBAHR6)

Address FFFFE30 – Memory Fine Base Address High Register 6

Bit Number	15:0
Bit Name	ADDRESS[31:16]
Access	R/W
Default	0000_0000_0000_0100

**Bits 15-0: ADDRESS[31:16]** – 16 Most Significant Bits of the Base Address. The Base Address sets the 22 most significant bits of the memory address.

### 3.9 Memory Fine Base Address High Register 7 (MFBAHR7)

Address FFFFFFFE38 – Memory Fine Base Address High Register 7

<b>Bit Number</b>	<b>15:0</b>
<b>Bit Name</b>	ADDRESS[31:16]
<b>Access</b>	R/W
<b>Default</b>	0000_0000_0000_0101

**Bits 15-0: ADDRESS[31:16]** – 16 Most Significant Bits of the Base Address. The Base Address sets the 22 most significant bits of the memory address.

### 3.10 Memory Fine Base Address High Register 8 (MFBAHR8)

Address FFFFFFFE40 – Memory Fine Base Address High Register 8

<b>Bit Number</b>	<b>15:0</b>
<b>Bit Name</b>	ADDRESS[31:16]
<b>Access</b>	R/W
<b>Default</b>	0000_0000_0000_0110

**Bits 15-0: ADDRESS[31:16]** – 16 Most Significant Bits of the Base Address. The Base Address sets the 22 most significant bits of the memory address.

### 3.11 Memory Fine Base Address High Register 9 (MFBAHR9)

Address FFFFFFFE48 – Memory Fine Base Address High Register 9

<b>Bit Number</b>	<b>15:0</b>
<b>Bit Name</b>	ADDRESS[31:16]
<b>Access</b>	R/W
<b>Default</b>	0000_0000_0000_0111

**Bits 15-0: ADDRESS[31:16]** – 16 Most Significant Bits of the Base Address. The Base Address sets the 22 most significant bits of the memory address.

### 3.12 Memory Fine Base Address High Register 10 (MFBAHR10)

Address FFFFFFFE50 – Memory Fine Base Address High Register 10

<b>Bit Number</b>	<b>15:0</b>
<b>Bit Name</b>	ADDRESS[31:16]
<b>Access</b>	R/W
<b>Default</b>	0000_0000_0000_1000

**Bits 15-0: ADDRESS[31:16]** – 16 Most Significant Bits of the Base Address. The Base Address sets the 22 most significant bits of the memory address.

### 3.13 Memory Fine Base Address High Register 11 (MFBAHR11)

Address FFFFE58 – Memory Fine Base Address High Register 11

<b>Bit Number</b>	<b>15:0</b>
<b>Bit Name</b>	ADDRESS[31:16]
<b>Access</b>	R/W
<b>Default</b>	0000_0000_0000_1001

**Bits 15-0: ADDRESS[31:16]** – 16 Most Significant Bits of the Base Address. The Base Address sets the 22 most significant bits of the memory address.

### 3.14 Memory Fine Base Address High Register 12 (MFBAHR12)

Address FFFFE60 – Memory Fine Base Address High Register 12

<b>Bit Number</b>	<b>15:0</b>
<b>Bit Name</b>	ADDRESS[31:16]
<b>Access</b>	R/W
<b>Default</b>	0000_0000_0000_1010

**Bits 15-0: ADDRESS[31:16]** – 16 Most Significant Bits of the Base Address. The Base Address sets the 22 most significant bits of the memory address.

### 3.15 Memory Fine Base Address High Register 13 (MFBAHR13)

Address FFFFE68 – Memory Fine Base Address High Register 13

<b>Bit Number</b>	<b>15:0</b>
<b>Bit Name</b>	ADDRESS[31:16]
<b>Access</b>	R/W
<b>Default</b>	0000_0000_0000_1011

**Bits 15-0: ADDRESS[31:16]** – 16 Most Significant Bits of the Base Address. The Base Address sets the 22 most significant bits of the memory address.

### 3.16 Memory Fine Base Address High Register 14 (MFBAHR14)

Address FFFFE70 – Memory Fine Base Address High Register 14

<b>Bit Number</b>	<b>15:0</b>
<b>Bit Name</b>	ADDRESS[31:16]
<b>Access</b>	R/W
<b>Default</b>	0000_0000_0000_1100

**Bits 15-0: ADDRESS[31:16]** – 16 Most Significant Bits of the Base Address. The Base Address sets the 22 most significant bits of the memory address.

### 3.17 Memory Fine Base Address High Register 15 (MFBAHR15)

Address FFFFFFFE78 – Memory Fine Base Address High Register 15

Bit Number	15:0
Bit Name	ADDRESS[31:16]
Access	R/W
Default	0000_0000_0000_1101

**Bits 15-0: ADDRESS[31:16]** – 16 Most Significant Bits of the Base Address. The Base Address sets the 22 most significant bits of the memory address.

### 3.18 Memory Fine Base Address High Register 16 (MFBAHR16)

Address FFFFFFFE80 – Memory Fine Base Address High Register 16

Bit Number	15:0
Bit Name	ADDRESS[31:16]
Access	R/W
Default	0000_0000_0000_1110

**Bits 15-0: ADDRESS[31:16]** – 16 Most Significant Bits of the Base Address. The Base Address sets the 22 most significant bits of the memory address.

### 3.19 Program Flash Control Register (PFLASHCTRL)

Address FFFFFFFE90

Bit Number	11	10	9	8	7:5	4:0
Bit Name	BUSY	RESERVED	PAGE_ERASE	MASS_ERASE	RESERVED	PAGE_SEL
Access	R	-	R/W	R/W	R/W	R/W
Default	-	0	0	0	000	00000

**Bit 11: BUSY** – Program Flash Busy Indicator  
 0 = Program Flash available for read/write/erase access  
 1 = Program Flash unavailable for read/write/erase access

**Bit 10: Reserved**

**Bit 9: PAGE\_ERASE** – Program Flash Page Erase Enable  
 0 = No Page Erase initiated on Program Flash (Default)  
 1 = Page Erase on Program Flash enabled. Page erased is based on PAGE\_SEL (Bits 4-0). Interlock Key must be set in Program Flash Interlock Register (Section 15.7) to initiate Page Erase cycle. This bit is cleared upon completion of Page Erase cycle.

**Bit 8: MASS\_ERASE** – Program Flash Mass Erase Enable  
 0 = No Mass Erase initiated on Program Flash (Default)  
 1 = Mass Erase of Program Flash enabled. Interlock Key must be set in Program Flash Interlock Register (Section 15.7) to initiate Mass Erase cycle. This bit is cleared upon completion of Mass Erase cycle.

**Bits 4-0: PAGE\_SEL** – Selects page to be erased during Page Erase Cycle

### 3.20 Data Flash Control Register (DFLASHCTRL)

Address FFFFFFFE94

Bit Number	11	10	9	8	7:6	5:0
Bit Name	BUSY	RESERVED	PAGE_ERASE	MASS_ERASE	RESERVED	PAGE_SEL
Access	R	-	R/W	R/W	-	R/W
Default	-	0	0	0	-	000000

**Bit 11: BUSY** – Data Flash Busy Indicator

0 = Data Flash available for read/write/erase access

1 = Data Flash unavailable for read/write/erase access

**Bit 10: Reserved**

**Bit 9: PAGE\_ERASE** – Data Flash Page Erase Enable

0 = No Page Erase initiated on Data Flash (Default)

1 = Page Erase Cycle on Data Flash enabled. Page erased is based on PAGE\_SEL (Bits 4-0). This bit is cleared upon completion of Page Erase cycle.

**Bit 8: MASS\_ERASE** – Data Flash Mass Erase Enable

0 = No Mass Erase initiated on Data Flash (Default)

1 = Mass Erase of Data Flash enabled. Bit is cleared upon completion of mass erase.

**Bits 5-0: PAGE\_SEL** – Selects page to be erased during Page Erase Cycle

### 3.21 Flash Interlock Register (FLASHLOCK)

Address FFFFFFFE98

Bit Number	31:0
Bit Name	INTERLOCK_KEY
Access	R/W
Default	0000_0000_0000_0000_0000_0000_0000_0000

**Bit 31-0: INTERLOCK\_KEY** – Flash Interlock Key. Register must be set to 0x42DC157E prior to every Flash write, Mass Erase or Page Erase. If the Interlock Key is not set, the write/erase cycle to the Flash will not initiate. This register will clear upon the completion of a write or erase cycle to the Flash modules.

## 4 CIM – Central Interrupt Module

CIM Registers have the following attributes:

- 32-bit wide
- Addresses placed on word boundaries
- Byte, half-word and word writes permitted
- All Registers have read/write access in any mode
- Interrupt Mask and FIQ/IRQ Program Control Registers are writeable in privilege mode only. A write in user mode to these Registers causes a peripheral illegal access exception.

### 4.1 IRQ Index Offset Vector Register (IRQIVEC)

Address FFFFFFF20

<b>Bit Number</b>	<b>7:0</b>
<b>Bit Name</b>	IRQIVEC
<b>Access</b>	R
<b>Default</b>	-

**Bits 7-0: IRQIVEC** – Index of the IRQ Pending Interrupt (Cleared upon read)

- 0 = No interrupt pending
- 1 = Pending interrupt on Channel 0
- 2 = Pending interrupt on Channel 1
- N = Pending interrupt on Channel N-1, where N <= 31

### 4.2 FIQ Index Offset Vector Register (FIQIVEC)

Address FFFFFFF24

<b>Bit Number</b>	<b>7:0</b>
<b>Bit Name</b>	FIQIVEC
<b>Access</b>	R
<b>Default</b>	-

**Bits 7-0: FIQIVEC** – Index of the FIQ pending interrupt (Cleared upon read)

- 0 = No interrupt pending
- 1 = Pending interrupt on Channel 0
- 2 = Pending interrupt on Channel 1
- N = Pending interrupt on Channel N-1, where N <= 31.

### 4.3 FIQ/IRQ Program Control Register (FIRQPR)

#### Address FFFFFFF2C

A 32-bit FIQ/IRQ program control Register (FIRQPR) determines whether a given interrupt request will be FIQ or IRQ type.

<b>Bit Number</b>	<b>31:0</b>
<b>Bit Name</b>	FIRQPR
<b>Access</b>	R/W
<b>Default</b>	0000_0000_0000_0000_0000_0000_0000_0000

**Bits 31-0: FIRQPR** – These bits determine whether an interrupt request from a peripheral is of type FIQ or IRQ. Each bit corresponds to one request channel. This Register is writeable in privilege mode only.

0 = Interrupt request is of IRQ type (Default)

1 = Interrupt request is of FIQ type

### 4.4 Pending Interrupt Read Location Register (INTREQ)

#### Address FFFFFFF30

<b>Bit Number</b>	<b>31:0</b>
<b>Bit Name</b>	INTREQ
<b>Access</b>	R
<b>Default</b>	-

**Bits 31-0: INTREQ** – Pending Interrupt Requests

0 = No interrupt has occurred

1 = Interrupt is pending

### 4.5 Interrupt Mask Register (REQMASK)

#### Address FFFFFFF34

<b>Bit Number</b>	<b>31:0</b>
<b>Bit Name</b>	REQMASK
<b>Access</b>	R/W
<b>Default</b>	0000_0000_0000_0000_0000_0000_0000_0000

**Bits 31-0: REQMASK** – Interrupt Request Mask Select

0 = Interrupt request channel is disabled (Default)

1 = Interrupt request channel is enabled

## 5 SYS – System Module

SYS Registers have the following attributes:

- 16-bit wide
- Addresses placed on word boundaries
- Byte, half-word and word writes permitted
- All Registers can be read in any mode of operation.
- Global Control Register is writeable in privilege mode only. All other Registers are writeable in any mode.

### 5.1 Clock Control Register (CLKCNTL)

#### Address FFFFFFFD0

The clock control Register configures the MCLK divider for low power modes and the clock multiplexer which drives the Sync pin when configured to output the CLKOUT signal. CLKCNTL is accessible in user and privilege mode and supports byte, half-word and word accesses. Any access to this Register takes two SYSCLK cycles.

Bit Number	9:8	7	6:5	4	3	2:0
Bit Name	M_DIV_RATIO	RESERVED	CLKSR	RESERVED	CLKDOUT	RESERVED
Access	-	-	R/W	-	R/W	-
Default	00	0	00	0	0	000

#### Bits 9-8: M\_DIV\_RATIO – MCLK (Processor Clock) Divide Ratio

- 00 = MCLK frequency equals High Frequency Oscillator divided by 8 (Default)
- 01 = MCLK frequency equals High Frequency Oscillator divided by 16
- 10 = MCLK frequency equals High Frequency Oscillator divided by 32
- 11 = MCLK frequency equals High Frequency Oscillator divided by 64

#### Bit 7: RESERVED

#### Bit 6-5: CLKSR – These bits control the source/function of CLKOUT

- 00 = Driven by value in CLKDOUT (Bit 3) (Default)
- 01 = Driven by the interface clock (ICLK)
- 10 = Reserved
- 11 = Driven by the system clock (MCLK)

#### Bit 4: RESERVED – Unused bit

#### Bit 3: CLKDOUT – This pin represents the output value of CLKOUT

- 0 = CLKOUT driven to logic low in output mode (Default)
- 1 = CLKOUT driven to logic high in output mode

#### Bits 2-0: RESERVED

### 5.2 System Exception Control Register (SYSECR)

#### Address FFFFFFFE0

The system exception control Register contains bits that allow the user to generate a software reset. The OVR bits disable some reset/abort conditions when TRST is high.

Bit Number	15:14	13:3	2	1	0
Bit Name	RESET	RESERVED	PACCOVR	ACCOVR	ILLOVR
Access	R/W	-	R/W	R/W	R/W



<b>Default</b>	01	-	0	0	0
----------------	----	---	---	---	---

**Bits 15-14: RESET** – Software Reset Enable. These bits always read as 01

01 = No reset

1X = Global system reset (X = don't care)

X0 = Global system reset (X = don't care)

**Bits 13-3: RESERVED**

**Bit 2: PACCOVR** – Peripheral Access Violation Override

0 = Peripheral access violation error causes a reset or abort (Default)

1 = No action taken on a peripheral access violation

**Bit 1: ACCOVR** – Memory Access Reset Override

0 = Memory access violation error causes a reset or abort (Default)

1 = No action taken on an illegal address

**Bit 0: ILLOVR** – Illegal Address Reset Override

0 = Illegal address causes a reset or abort (Default)

1 = No action taken on an illegal address

### 5.3 System Exception Status Register (SYSESR)

#### Address FFFFFFFE4

The System Exception Status Register contains flags for different reset/abort sources. On power-up, all bits are cleared to 0. When a reset condition is recognized, the appropriate bit in the Register is set and the value of the bit is maintained through the reset. When a new reset condition occurs, the current contents of this Register are not cleared. The contents of this Register are cleared on a power-on reset or by software.

Bit Number	15	14	13	12	11	10
<b>Bit Name</b>	PORRST	CLKRST	WDRST	ILLMODE	ILLADR	ILLACC
<b>Access</b>	R/W	R/W	R/W	R/W	R/W	R/W
<b>Default</b>	0	0	0	0	0	0

Bit Number	9	8	7	6:0
<b>Bit Name</b>	PILLACC	ILLMAP	SWRST	RESERVED
<b>Access</b>	R/W	R/W	R/W	-
<b>Default</b>	0	0	0	000_0000

**Bit 15: PORRST** – Power-On reset flag. Set when power-on reset is asserted. Reset is asserted as long as power-on-reset is active. Whenever a device is powered, this bit is set.

User and privilege modes (read)

0 = Power-up reset has not occurred since the last clear

1 = Power-up reset has occurred since the last clear

User and privilege modes (write)

0 = Clears the corresponding bit to 0

1 = No effect

**Bit 14: CLKRST** – This bit represents the clock fail flag. This bit indicates a clock fault condition has occurred.

After power-on-reset, the CLKRST is reset to 0. Value remains unchanged during other resets.

User and privilege modes (read)

0 = Clock failure has not occurred since the last clear

1 = Clock failure has occurred since the last clear

User and privilege modes (write)

0 = Clears the corresponding bit to 0

1 = No effect

**Bit 13: WDRST** – This bit represents the watchdog reset flag. This bit indicates that the last reset was caused by the watchdog.

User and privilege modes (read)  
 0 = Watchdog reset has not occurred since the last clear  
 1 = Watchdog reset has occurred since the last clear  
 User and privilege modes (write)  
 0 = Clears the corresponding bit to 0  
 1 = No effect

**Bit 12: ILLMODE** – This bit represents the illegal mode flag. This bit is set when the mode bits in the program status Register are set to an illegal value.

User and privilege modes (read)  
 0 = Illegal mode has not occurred since the last clear  
 1 = Illegal mode has occurred since the last clear  
 User and privilege modes (write)  
 0 = Clears the corresponding bit to 0  
 1 = No effect

**Bit 11: ILLADR** – This bit represents the illegal address access flag. This bit is set when an access to an unimplemented location in the memory map is detected in non-user mode.

User and privilege modes (read)  
 0 = Illegal address has not occurred since the last clear  
 1 = Illegal address has occurred since the last clear  
 User and privilege modes (write)  
 0 = Clears the corresponding bit to 0  
 1 = No effect

**Bit 10: ILLACC** – This bit represents the illegal memory access flag. This bit is set when an access to a protected location without permission rights is detected in non-user mode.

User and privilege modes (read)  
 0 = Illegal memory access has not occurred since the last clear  
 1 = Illegal memory access has occurred since the last clear  
 User and privilege modes (write)  
 0 = Clears the corresponding bit to 0  
 1 = No effect

**Bit 9: PILLACC** – This bit represents the peripheral illegal access flag. This bit is set when a peripheral access violation is detected in user mode.

User and privilege modes (read)  
 0 = Illegal peripheral access has not occurred since the last clear  
 1 = Illegal peripheral access has occurred since the last clear  
 User and privilege modes (write)  
 0 = Clears the corresponding bit to 0  
 1 = No effect

**Bit 8: ILLMAP** – This bit represents the illegal address map flag. This bit is set when the base addresses of one or more memories overlap. Reset occurs when the overlapped registration is accessed.

User and privilege modes (read)  
 0 = Illegal address mapping has not occurred since the last clear  
 1 = Illegal address mapping has occurred since the last clear  
 User and privilege modes (write)  
 0 = Clears the corresponding bit to 0  
 1 = No effect

**Bit 7: SWRST** – This bit represents the software reset flag. This bit is set when the last reset is caused by software writing the RESET bits.

User and privilege modes (read)  
 0 = Software reset has not occurred since the last clear  
 1 = Software reset has occurred since the last clear  
 User and privilege modes (write)  
 0 = Clears the corresponding bit to 0  
 1 = No effect

**Bit 6-0: RESERVED**

### 5.4 Abort Exception Status Register (ABRTESR)

**Address FFFFFFFE8**

The Abort Exception Status Register shows the abort cause.

Bit Number	15	14	13	12:0
Bit Name	ADRABT	MEMABT	PACCVIO	RESERVED
Access	R/W	R/W	R/W	-
Default	0	0	0	0_0000_0000_0000

**Bit 15: ADRABT** – This bit represents the illegal address abort. An illegal address access was detected in user mode. An abort was generated due to an illegal address access from either the MPU or system

User and privilege modes (read)

0 = No illegal address

1 = Abort caused by an illegal address

User and privilege modes (write)

0 = Clears bit to 0

1 = No effect

**Bit 14: MEMABT** – This bit represents the memory access abort. This bit indicates an illegal memory access was detected in user mode. An abort was generated due to the illegal memory access from either the MPU or system.

User and privilege modes (read)

0 = No illegal memory access

1 = Abort caused by an illegal memory access

User and privilege modes (write)

0 = Clears bit to 0

1 = No effect

**Bit 13: PACCVIO** – This bit represents the peripheral access violation error. This bit indicates a peripheral access violation error was detected during a peripheral Register access in user mode. An abort was generated due to a peripheral access violation.

User and privilege modes (read)

0 = No peripheral access violation

1 = Abort caused by a peripheral access violation

User and privilege modes (write)

0 = Clears bit to 0

1 = No effect

**Bit 12-0: RESERVED** – Unused bits

### 5.5 Global Status Register (GLBSTAT)

**Address FFFFFFFEC**

The Global Status Register specifies the module that triggered the illegal address, illegal access, abort or reset. When a new reset condition reset occurs, the current contents of this Register are not cleared. The contents of this Register are cleared on a power-on reset or by software.

Bit Number	7	6	5:0
Bit Name	SYSADDR	SYSACC	RESERVED
Access	R/W	R/W	-
Default	0	0	0000

**Bit 7: SYSADDR** – This bit represents the system illegal address flag. This bit is set when the system detects an illegal address.

User and privilege modes (read)

0 = No system illegal address

1 = Abort or reset caused by a system illegal address  
 User and privilege modes (write)  
 0 = Clears bit to 0  
 1 = No effect

**Bit 6: SYSACC** – This bit represents the system illegal access flag. This bit is set when the system detects an illegal access.

User and privilege modes (read)  
 0 = No system illegal access  
 1 = Abort or reset caused by a system illegal access  
 User and privilege modes (write)  
 0 = Clears bit to 0  
 1 = No effect

#### Bit 5-0: RESERVED

## 5.6 Device Identification Register (DEV)

### Address FFFFFFFF0

The Device Identification Register contains device specification information that is hard coded during device manufacturing. This register is read-only.

<b>Bit Number</b>	<b>15:0</b>
<b>Bit Name</b>	DEV
<b>Access</b>	R
<b>Default</b>	1000_0100_0111_1111

**Bits 15-0: DEV** – These bits represent the device identification code.

## 5.7 System Software Interrupt Flag Register (SSIF)

### Address FFFFFFFF8

The System Software Interrupt Flag Register is set when a software interrupt is triggered. The flag allows the user to poll for a software interrupt.

<b>Bit Number</b>	<b>0</b>
<b>Bit Name</b>	SSIFLAG
<b>Access</b>	R/W
<b>Default</b>	0

**Bit 0: SSIFLAG** – This bit represents the system software interrupt flag. This bit is set when a correct SSKEY is written to the System Software Interrupt Flag Register. This bit is cleared only by software.

User and privilege modes (read)  
 0 = No IRQ/FIQ interrupt request has been generated since the last clear  
 1 = IRQ/FIQ interrupt request has been generated since the last clear  
 User and privilege modes (write)  
 0 = Clears bit to 0  
 1 = No effect

### **A.10.9 System Software Interrupt Request Register (SSIR)**

#### **Address FFFFFFFC**

The System Software Interrupt Request Register contains a key sequence that triggers a software interrupt request to the CIM. Also, the Register contains an 8-bit data field.

<b>Bit Number</b>	<b>15:8</b>	<b>7:0</b>
<b>Bit Name</b>	SSKEY	SSDATA
<b>Access</b>	R/W	R/W
<b>Default</b>	0000_0000	0000_0000

**Bits 15-8: SSKEY** – These bits represent the system software interrupt request key. These write-only bits are executable in both user and privilege modes. A 0x75 written to these bits initiates IRQ/FIQ interrupts. Data in this field is always read as zero.

**Bits 7-0: SSDATA** – These bits represent the system software interrupt data. The SSDATA bits provide an 8-bit field that can be used for passing messages into the system software interrupt.

#### **Revision History:**

- SLUA741, April 2015 to SLUA741A →  
Removed Internal Draft Only Footer
- SLUA741A, May 2015 to SLUA741B →  
Updated 3.1 LLC Topology section  
Updated 3.2 PS-LLC Topology section
- SLUA741B, June 2015 to SLUA741C  
Updated Front End, Auto Gear Shift AFE Gain description in Table 2, “Enhancements in UCD3138A”.  
Updated DPWM, Improved transient response... description in Table 2, “Enhancements in UCD3138A”.  
Updated section 3.1, LLC Topology values from 120ns to 132ns.  
Updated section 3.5, PFC Topology values from 120ns to 132ns and 480ns to 528ns.  
Updated section 4.1, Increase in DPWM Event Update Window values from 120ns to 132ns in three places.
- SLUA741C, October 2015 to SLUA741D  
Updated .pdf file, not changes to the document.

## IMPORTANT NOTICE

Texas Instruments Incorporated and its subsidiaries (TI) reserve the right to make corrections, enhancements, improvements and other changes to its semiconductor products and services per JESD46, latest issue, and to discontinue any product or service per JESD48, latest issue. Buyers should obtain the latest relevant information before placing orders and should verify that such information is current and complete. All semiconductor products (also referred to herein as "components") are sold subject to TI's terms and conditions of sale supplied at the time of order acknowledgment.

TI warrants performance of its components to the specifications applicable at the time of sale, in accordance with the warranty in TI's terms and conditions of sale of semiconductor products. Testing and other quality control techniques are used to the extent TI deems necessary to support this warranty. Except where mandated by applicable law, testing of all parameters of each component is not necessarily performed.

TI assumes no liability for applications assistance or the design of Buyers' products. Buyers are responsible for their products and applications using TI components. To minimize the risks associated with Buyers' products and applications, Buyers should provide adequate design and operating safeguards.

TI does not warrant or represent that any license, either express or implied, is granted under any patent right, copyright, mask work right, or other intellectual property right relating to any combination, machine, or process in which TI components or services are used. Information published by TI regarding third-party products or services does not constitute a license to use such products or services or a warranty or endorsement thereof. Use of such information may require a license from a third party under the patents or other intellectual property of the third party, or a license from TI under the patents or other intellectual property of TI.

Reproduction of significant portions of TI information in TI data books or data sheets is permissible only if reproduction is without alteration and is accompanied by all associated warranties, conditions, limitations, and notices. TI is not responsible or liable for such altered documentation. Information of third parties may be subject to additional restrictions.

Resale of TI components or services with statements different from or beyond the parameters stated by TI for that component or service voids all express and any implied warranties for the associated TI component or service and is an unfair and deceptive business practice. TI is not responsible or liable for any such statements.

Buyer acknowledges and agrees that it is solely responsible for compliance with all legal, regulatory and safety-related requirements concerning its products, and any use of TI components in its applications, notwithstanding any applications-related information or support that may be provided by TI. Buyer represents and agrees that it has all the necessary expertise to create and implement safeguards which anticipate dangerous consequences of failures, monitor failures and their consequences, lessen the likelihood of failures that might cause harm and take appropriate remedial actions. Buyer will fully indemnify TI and its representatives against any damages arising out of the use of any TI components in safety-critical applications.

In some cases, TI components may be promoted specifically to facilitate safety-related applications. With such components, TI's goal is to help enable customers to design and create their own end-product solutions that meet applicable functional safety standards and requirements. Nonetheless, such components are subject to these terms.

No TI components are authorized for use in FDA Class III (or similar life-critical medical equipment) unless authorized officers of the parties have executed a special agreement specifically governing such use.

Only those TI components which TI has specifically designated as military grade or "enhanced plastic" are designed and intended for use in military/aerospace applications or environments. Buyer acknowledges and agrees that any military or aerospace use of TI components which have **not** been so designated is solely at the Buyer's risk, and that Buyer is solely responsible for compliance with all legal and regulatory requirements in connection with such use.

TI has specifically designated certain components as meeting ISO/TS16949 requirements, mainly for automotive use. In any case of use of non-designated products, TI will not be responsible for any failure to meet ISO/TS16949.

### Products

Audio	<a href="http://www.ti.com/audio">www.ti.com/audio</a>
Amplifiers	<a href="http://amplifier.ti.com">amplifier.ti.com</a>
Data Converters	<a href="http://dataconverter.ti.com">dataconverter.ti.com</a>
DLP® Products	<a href="http://www.dlp.com">www.dlp.com</a>
DSP	<a href="http://dsp.ti.com">dsp.ti.com</a>
Clocks and Timers	<a href="http://www.ti.com/clocks">www.ti.com/clocks</a>
Interface	<a href="http://interface.ti.com">interface.ti.com</a>
Logic	<a href="http://logic.ti.com">logic.ti.com</a>
Power Mgmt	<a href="http://power.ti.com">power.ti.com</a>
Microcontrollers	<a href="http://microcontroller.ti.com">microcontroller.ti.com</a>
RFID	<a href="http://www.ti-rfid.com">www.ti-rfid.com</a>
OMAP Applications Processors	<a href="http://www.ti.com/omap">www.ti.com/omap</a>
Wireless Connectivity	<a href="http://www.ti.com/wirelessconnectivity">www.ti.com/wirelessconnectivity</a>

### Applications

Automotive and Transportation	<a href="http://www.ti.com/automotive">www.ti.com/automotive</a>
Communications and Telecom	<a href="http://www.ti.com/communications">www.ti.com/communications</a>
Computers and Peripherals	<a href="http://www.ti.com/computers">www.ti.com/computers</a>
Consumer Electronics	<a href="http://www.ti.com/consumer-apps">www.ti.com/consumer-apps</a>
Energy and Lighting	<a href="http://www.ti.com/energy">www.ti.com/energy</a>
Industrial	<a href="http://www.ti.com/industrial">www.ti.com/industrial</a>
Medical	<a href="http://www.ti.com/medical">www.ti.com/medical</a>
Security	<a href="http://www.ti.com/security">www.ti.com/security</a>
Space, Avionics and Defense	<a href="http://www.ti.com/space-avionics-defense">www.ti.com/space-avionics-defense</a>
Video and Imaging	<a href="http://www.ti.com/video">www.ti.com/video</a>

### TI E2E Community

[e2e.ti.com](http://e2e.ti.com)